

ASSEMBLY INSTRUCTIONS

(BOX 1) Box of Headboard		
NO.	Descriptions	Qty.
A	Headboard Panel	1
B	Headboard Leg Right (R)	1
C	Headboard Leg Left (L)	1
D	Footboard Panel	1
E	Slat Support	5
F	Bed Slat (With Stopper)	2
G	Bed Slat	3

(BOX 1) Box of Headboard (Hardware List)		
NO.	Descriptions	Qty.
1	JCBC Screw M6 x50mm	5
2	JCBC Screw M6 x30mm Spring Washer Ø 1/4" Flat Washer Ø 1/4" x 13mm	6
3	CSK M4 x 16mm	15
4	CSK M4 x 32mm	10
5	L Key M4	1
6	L Key M5	1

(BOX 2) Box of Side Rail		
NO.	Descriptions	Qty.
H	Slat Panel	5
I	Center Slat	1
J	Side Rail	2

STEP 1

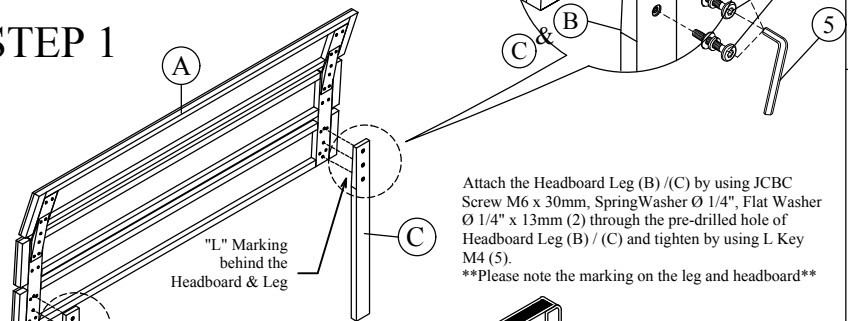

STEP 2

Attach the Side Rail (J) to Headboard Leg (B/C). Tighten screw on Headboard Leg (B/C) by using L Key M5 (6) & repeat the same step on Footboard Leg (D).

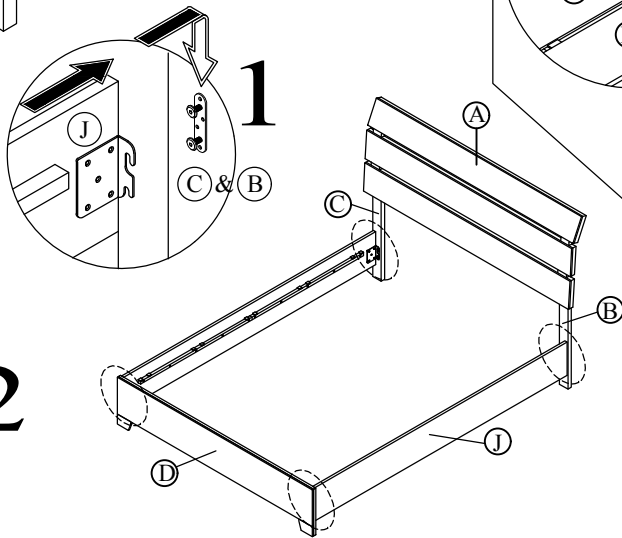

STEP 3

Attach the Center Slat (I), Bed Slat With Stopper (F) & Bed Slat (G) to Slat Support (E). Tighten with JCBC M6 x 50mm (1) by using L Key M4 (5).

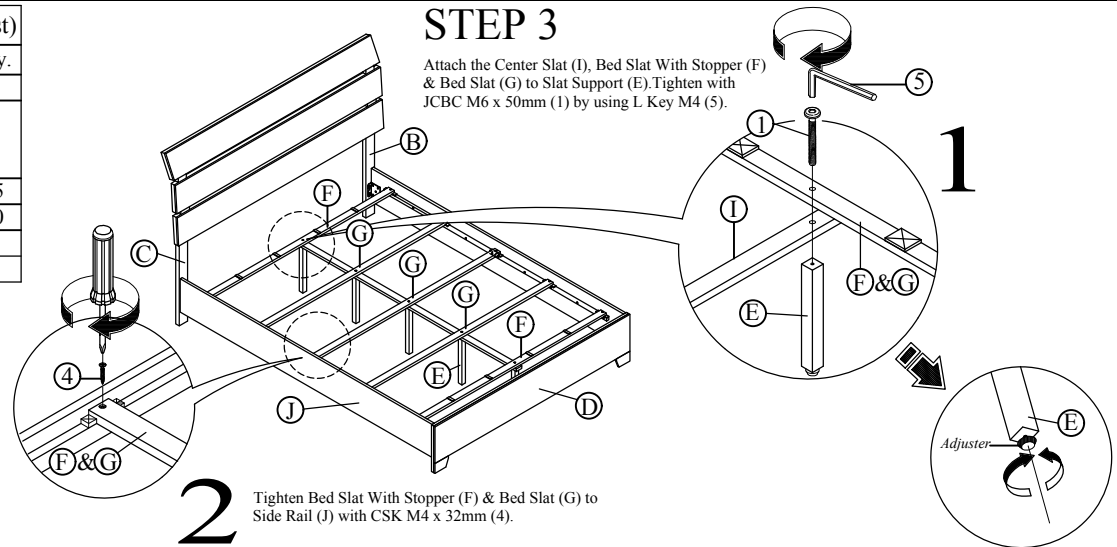

Close the distance Slat Panel (H) to stopper at Bed Slat With Stopper (F). Tighten Slat Panel (H) to Bed Slat With Stopper (F) with CSK M4 x 16mm(3).

STEP 4

Attach the Slat Panel (H) to top Bed Slat With Stopper (F) & Bed Slat (G) .

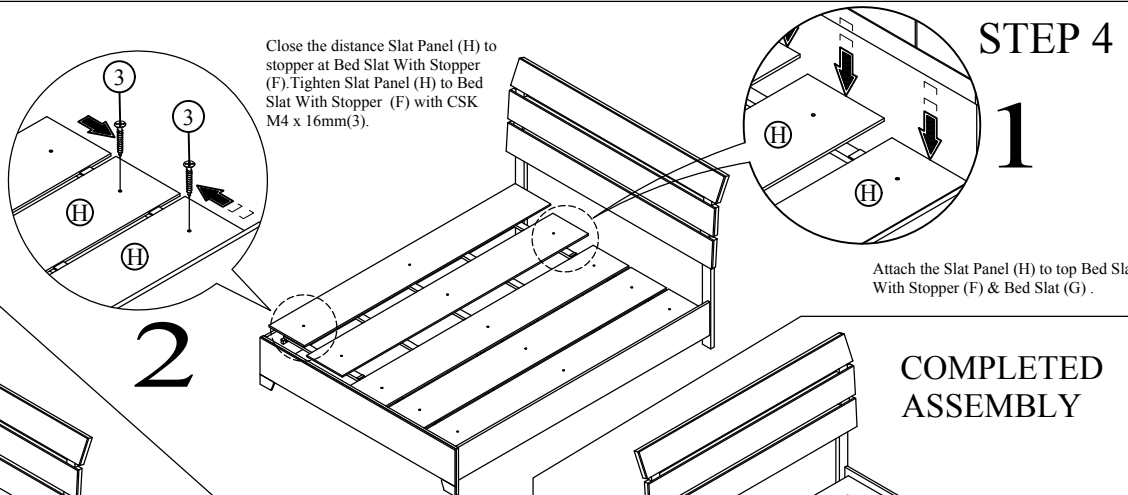

COMPLETED ASSEMBLY