

**ASSEMBLY INSTRUCTIONS
(INSTRUCTIONS DE MONTAGE)
30 INCH BATH VANITY (COMBO)
MEUBLE-LAVABO DE 30 POUCES (COMBO)**

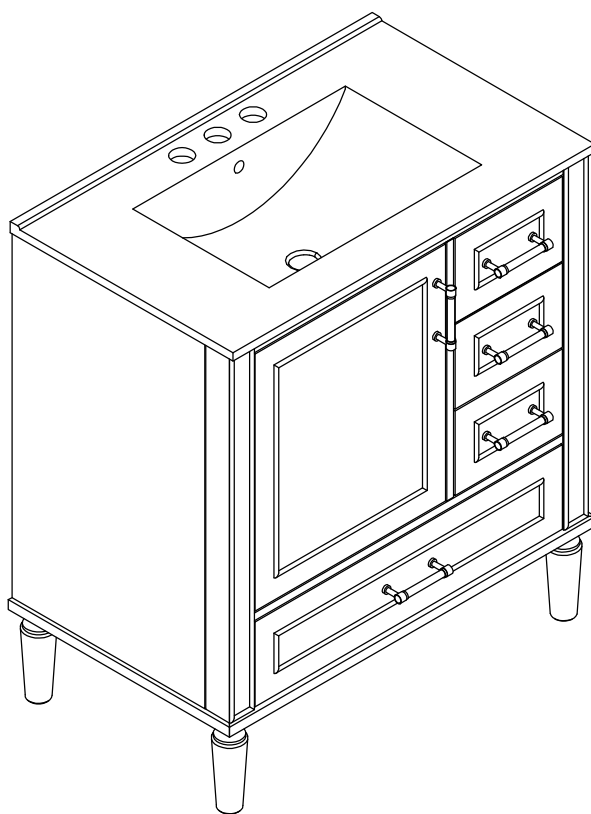

Thank you for purchasing this quality product. Be sure to check all pack material carefully for small parts which may have come loose inside the carton during shipment. Separate, identify and count all parts and hardware. Compare with the parts list to be sure all parts are present.

"DO NOT TIGHTEN SCREWS UNTIL COMPLETELY ASSEMBLED"

Merci d'avoir acheté ce produit de qualité. Assurez-vous de vérifier soigneusement tout le matériel d'emballage pour détecter les petites pièces qui auraient pu se détacher à l'intérieur du carton pendant le transport. Séparez, identifiez et comptez toutes les pièces et le matériel. Comparez avec la liste des pièces pour vous assurer que toutes les pièces sont présentes.

"NE SERREZ PAS LES VIS AVANT D'ÊTRE COMPLÈTEMENT ASSEMBLÉES"

* Use of power tool to assemble this product will invalidate any claim and damage this product making unsafe !!!
* Please assemble on a clean soft surface to avoid damage.

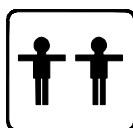
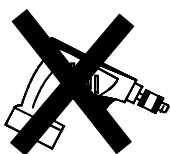

Tools Required

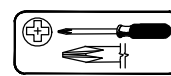

(Not included)

IMPORTANT:

**PLEASE READ INSTRUCTION BEFORE STARTING THE ASSEMBLY
VEUILLEZ LIRE LES INSTRUCTIONS AVANT DE COMMENCER L'ASSEMBLAGE**

Before Installation

Important - Please read these instructions fully before starting assembly

Thank you for purchasing this quality product. Be sure to check all packing materials carefully for small parts, which may have come loose inside the carton during shipment. Identify and count all items according to the PARTS LIST and/or HARDWARE LIST shown below. Check you have all the components and tools listed on the following pages.

- . We recommend that you assemble this product with the assistance of another person; this will make the assembly easier, and will help eliminate damage to the product or injury to persons during assembly.
- . Please do not over tighten screws or bolts until the assembly is completed.
- . Keep children and animal away from the work area, small parts could choke if swallowed.
- . Please put all parts on a non-abrasive floor before assembly, and follow the assembly steps to assemble your newly purchased product correctly and efficiently.

If you find that you have any trouble with assembly or missing or damaged parts please contact the seller.

Cam Lock Assembly Instructions

		Diagram A Insert Cam Bolt into hole as shown in diagram A.
		Diagram B Make sure not to insert the Cam Bolt too deep as shown in figure B as this will cause the Cam Lock to be misaligned and unable to interlock properly.
		Diagram C Also avoid inserting the Cam Bolt too close to the surface of the hole as shown in figure C, as this will cause the Cam Lock to be too loose, and not interlock properly.
		Connect the panels together.
		ARROW SIGN Insert the Cam Lock so the side opening fits over the head of the Cam Bolt.
		To tighten the Cam Lock, turn it clockwise on half a turn with a flat screwdriver. <i>*Do not use an automatic screwdriver as it may bend or break if too much power is imposed.</i>

Avant l'installation

Important - Veuillez lire entièrement ces instructions avant de commencer l'assemblage.

Merci d'avoir acheté ce produit de qualité. Assurez-vous de vérifier soigneusement tous les matériaux d'emballage pour détecter les petites pièces qui pourraient s'être détachées à l'intérieur du carton pendant le transport. Identifiez et comptez tous les éléments conformément à la LISTE DES PIÈCES et/ou à la LISTE DU MATÉRIEL indiquée ci-dessous. Vérifiez que vous disposez de tous les composants et outils répertoriés dans les pages suivantes.

- Nous vous recommandons d'assembler ce produit avec l'aide d'une autre personne ; cela facilitera l'assemblage et aidera à éliminer les dommages au produit ou les blessures corporelles pendant l'assemblage.

- Veuillez ne pas trop serrer les vis ou les boulons jusqu'à ce que l'assemblage soit terminé.

- Tenir les enfants et les animaux éloignés de la zone de travail, les petites pièces pourraient s'étouffer en cas d'ingestion.

- Veuillez placer toutes les pièces sur un sol non abrasif avant l'assemblage et suivre les étapes d'assemblage pour assembler correctement et efficacement votre produit nouvellement acheté.

Si vous constatez des problèmes d'assemblage ou des pièces manquantes ou endommagées, veuillez contacter le vendeur.

Instructions d'assemblage du verrou à came

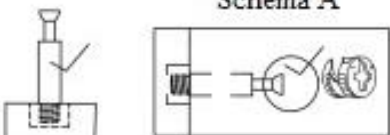
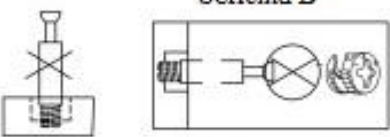
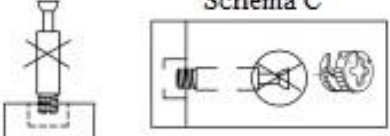
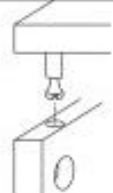
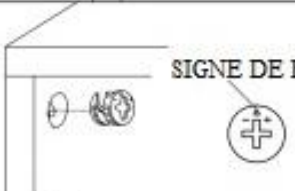
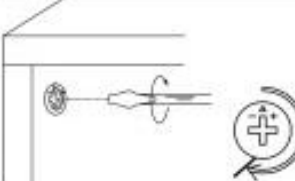
	<p>Schéma A</p> <p>Insérez le boulon à came dans le trou comme indiqué sur le schéma A.</p>
	<p>Schéma B</p> <p>Assurez-vous de ne pas insérer le boulon à came : Trop profond, comme indiqué sur la figure B, car cela entraînerait un mauvais alignement du Cam Lock et son incapacité à se verrouiller correctement.</p>
	<p>Schéma C</p> <p>Évitez également d'insérer le boulon à came trop près de la surface du trou, comme indiqué sur la figure C, car cela rendrait le verrou à came trop lâche et ne s'emboîterait pas correctement.</p>
	<p>Connectez les panneaux ensemble.</p>
	<p>SIGNE DE FLÈCHE</p> <p>Insérez le verrou à came de manière à ce que l'ouverture latérale s'ajuste sur la tête du boulon à came.</p>
	<p>Pour serrer le Cam Lock, tournez-le d'un demi-tour dans le sens des aiguilles d'une montre à l'aide d'un tournevis plat.</p> <p>*N'utilisez pas de tournevis automatique car il pourrait se plier ou se casser si trop de puissance</p>

Detail View - CABINET
(Vue détaillée - ARMOIRE)

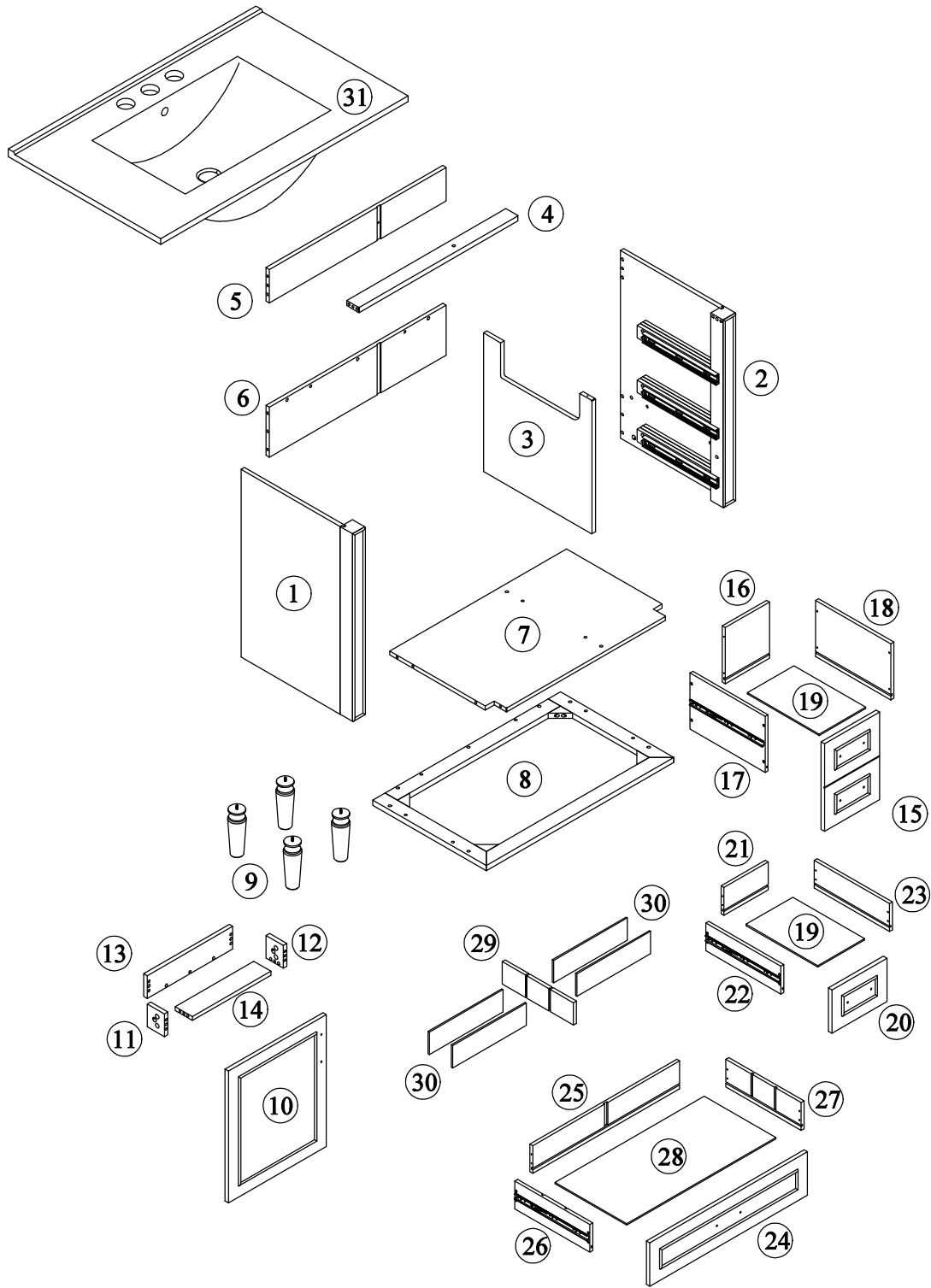

Identifying the Hardware-Identify the hardware using the illustrations below.
 (Identification du matériel - Identification du matériel à l'aide des illustrations ci-dessous)

Part List (Liste des pièces)

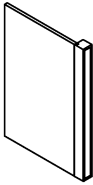
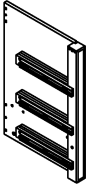
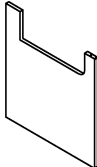
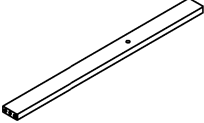
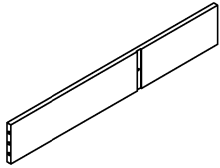
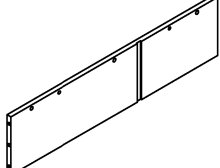
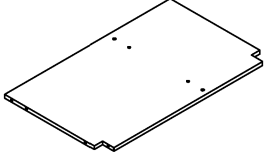
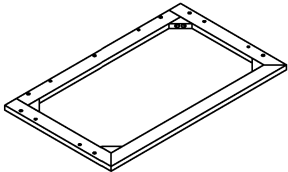
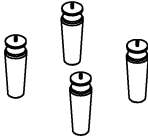
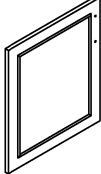
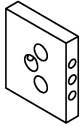
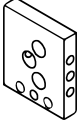
<p>1</p>  <p>Side Panel (L) - 1pc (Côté panneaux)</p>	<p>2</p>  <p>Side Panel (R) - 1pc (Côté panneaux)</p>
<p>3</p>  <p>Mid Panel (A) - 1pc (Milieu panneaux)</p>	<p>4</p>  <p>Top Bar Front- 1pc (Barre avant supérieure)</p>
<p>5</p>  <p>Top Panel Rear - 1pc (Arrière panneaux haut)</p>	<p>6</p>  <p>Bottom Panel Rear - 1pc (Arrière panneaux bas)</p>
<p>7</p>  <p>Mid Panel (B) - 1pc (Milieu panneaux)</p>	<p>8</p>  <p>Frame Bottom - 1pc (Bas Cadre)</p>
<p>9</p>  <p>Foot Cabinet - 4pcs (Pieds d'armoire)</p>	<p>10</p>  <p>Door Cabinet(L) - 1pc (Armoire à portes)</p>
<p>11</p>  <p>Side Panel Door (L) - 1pc (Porte du panneau latéral)</p>	<p>12</p>  <p>Side Panel Door (R) - 1pc (Porte du panneau latéral)</p>



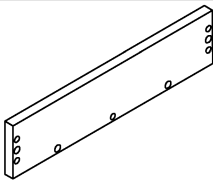
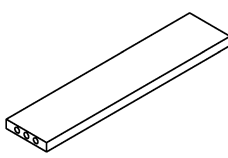
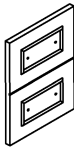
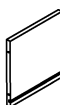
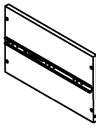
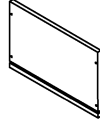
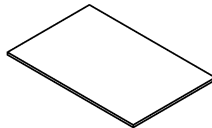
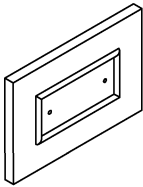
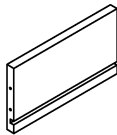
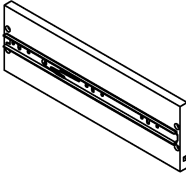
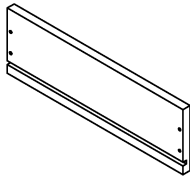
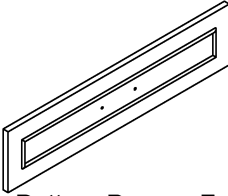



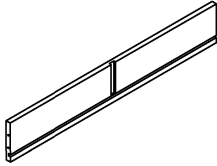
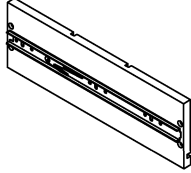
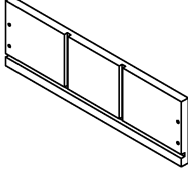
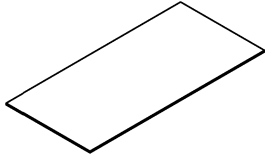
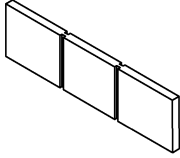
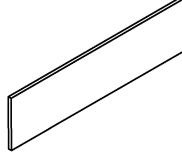
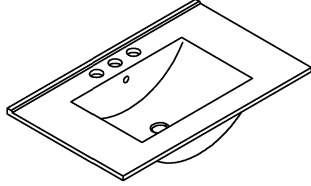

Part List (Liste des pièces)

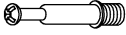
13		14	
	<p>Rear Panel Door - 1pc (Porte du panneau arrière)</p>		<p>Bottom Panel Door - 1pc (Porte du panneau inférieur)</p>
15		16	
	<p>Top Drawer Face - 1pc (Tiroir devant)</p>		<p>Top Drawer Panel rear - 1pc (Tiroir arrière)</p>
17		18	
	<p>Top Drawer Side Panel (L) - 1pc (Tiroir côté)</p>		<p>Top Drawer Side Panel (R) - 1pc (Tiroir côté)</p>
19		20	
	<p>Panel Bottom - 2pcs (Tiroir du bas)</p>		<p>Mid Drawer Face - 1pc (Tiroir devant)</p>
21		22	
	<p>Mid Drawer Panel rear - 1pc (Tiroir arrière)</p>		<p>Mid Drawer Side Panel (L) - 1pc (Tiroir côté)</p>
23		24	
	<p>Mid Drawer Side Panel (R) - 1pc (Tiroir côté)</p>		<p>Bottom Drawer Face - 1pc (Tiroir devant)</p>

Part List (Liste des pièces)

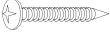
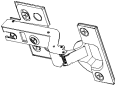
<p>25</p>  <p>Bottom Drawer Panel rear - 1pc (Tiroir arrière)</p>	<p>26</p>  <p>Bottom Drawer Side Panel (L) - 1pc (Tiroir côté)</p>
<p>27</p>  <p>Bottom Drawer Side Panel (R) - 1pc (Tiroir côté)</p>	<p>28</p>  <p>Panel Bottom - 1pc (Tiroir du bas)</p>
<p>29</p>  <p>Drawer divide (A) - 1pc (Séparation des tiroirs)</p>	<p>30</p>  <p>Drawer divide (B) - 4pcs (Séparation des tiroirs)</p>
<p>31</p>  <p>Sink - 1pc (Lavabo)</p>	

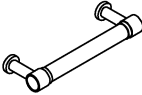
Hardware List (Liste du matériel)

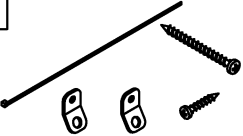
<p>A</p>  <p>Ø6x35mm</p>	<p>B</p>  <p>Ø14.5x9.5mm</p>	<p>C</p>  <p>Ø8x30mm</p>
<p>Three in one bolts - 38pcs (Boulons trois en un)</p>	<p>Three in one lock - 38pcs (Serrure trois en un)</p>	<p>Wood dowel - 31pcs (Cheville en bois)</p>
<p>D</p>  <p>Ø8xØ4x25mm</p>	<p>E</p>  <p>Ø8xØ4x32mm</p>	<p>F</p> 
<p>Round head screw - 2pcs (Vis à tête ronde)</p>	<p>Round head screw - 24pcs (Vis à tête ronde)</p>	<p>Damping hinge - 2pcs (Charnière amortissante)</p>
<p>G</p>  <p>Ø7xØ3.5x15mm</p>	<p>H</p> 	<p>I</p>  <p>Ø5/32"x15mm</p>
<p>Flat head screw - 12pcs (Vis à tête plate)</p>	<p>Handle - 5pcs (Poignées)</p>	<p>Handle screw - 4pcs (Vis de poignée)</p>
<p>J</p>  <p>Ø5/32"x30mm</p>	<p>K</p> 	
<p>Handle screw - 6pcs (Vis de poignée)</p>	<p>Anti fall hardware - 1set (Quincaillerie anti-chute)</p>	

STEP: 1
(ÉTAPE: 1)

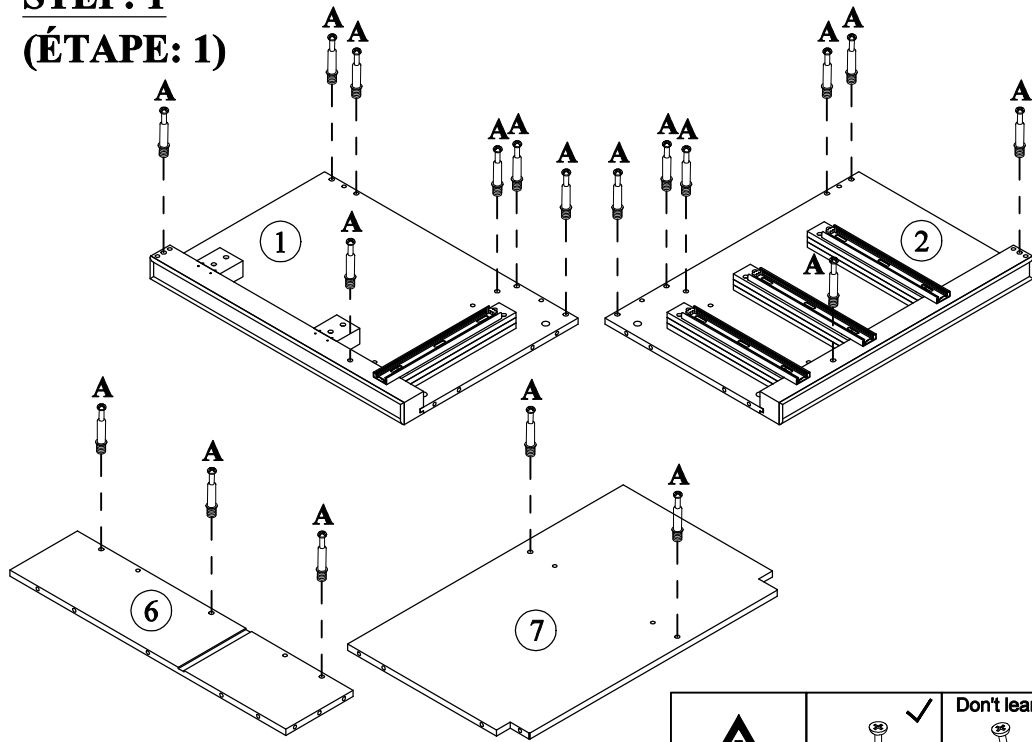

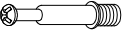
A	
	19PCS

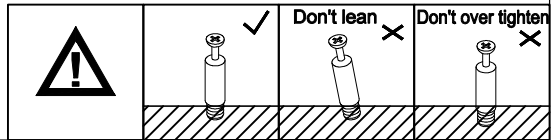

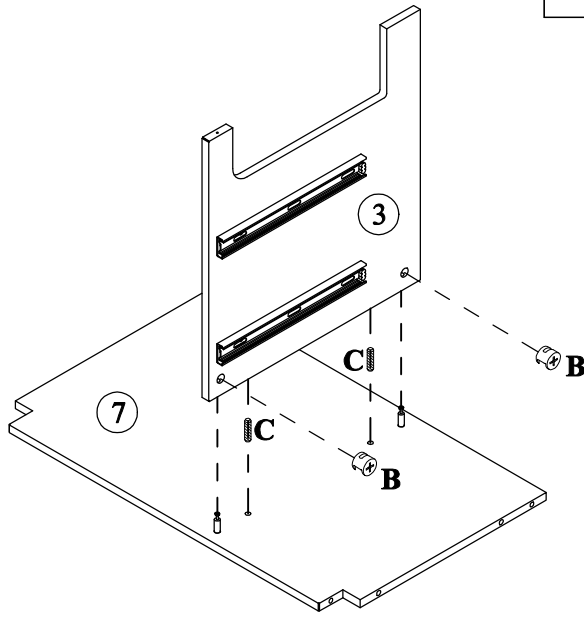

STEP: 2.
(ÉTAPE: 2)

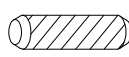

B		C	
	2PCS		2PCS

STEP: 3
(ÉTAPE: 3)

B		C		D	
	3PCS		2PCS		1PC

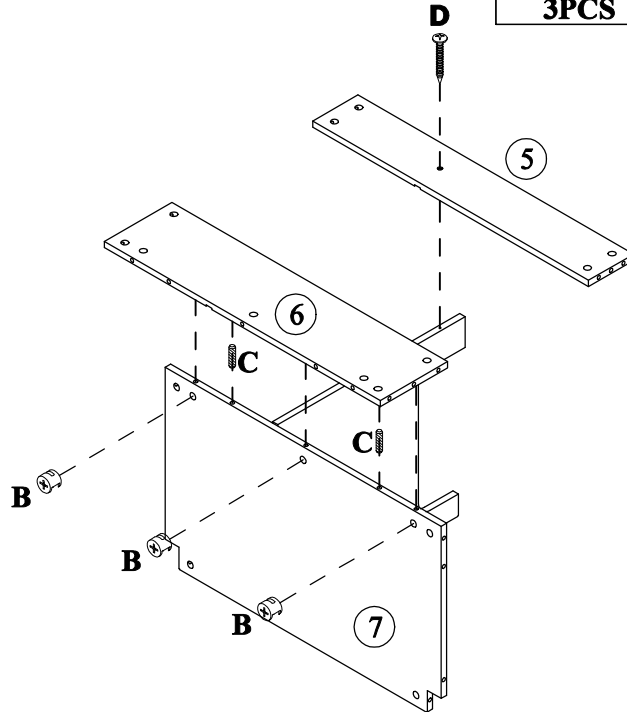

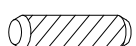

STEP: 4
(ÉTAPE: 4)

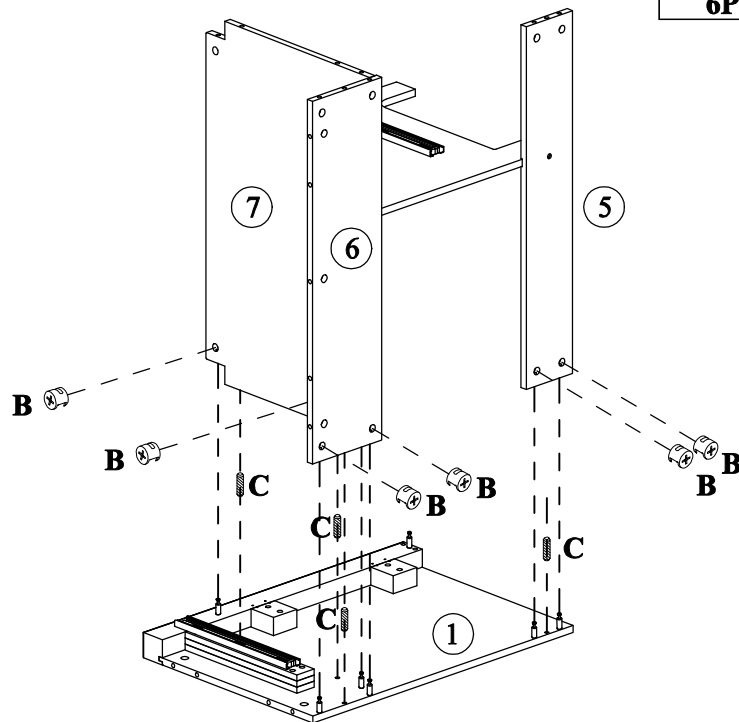
B		C	
	6PCS		4PCS



STEP: 5
(ÉTAPE: 5)

B		C		D	
	1PC		2PCS		1PC

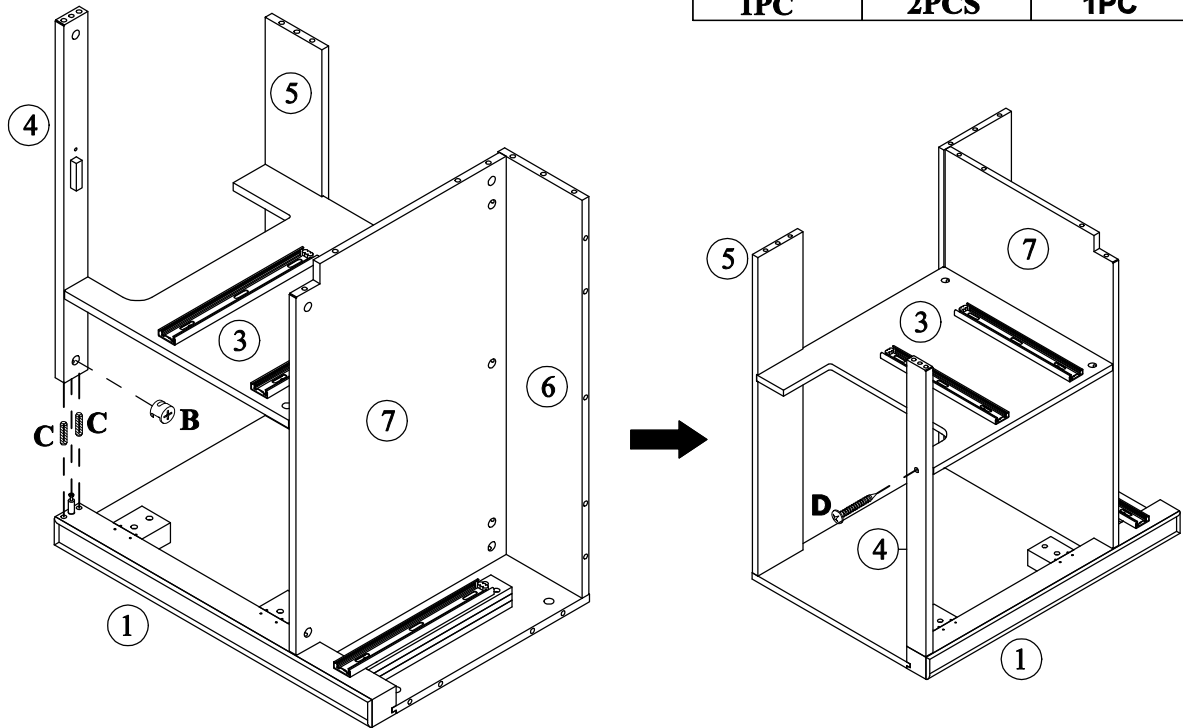

STEP: 6
(ÉTAPE: 6)

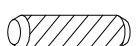
B		C	
	7PCS		6PCS

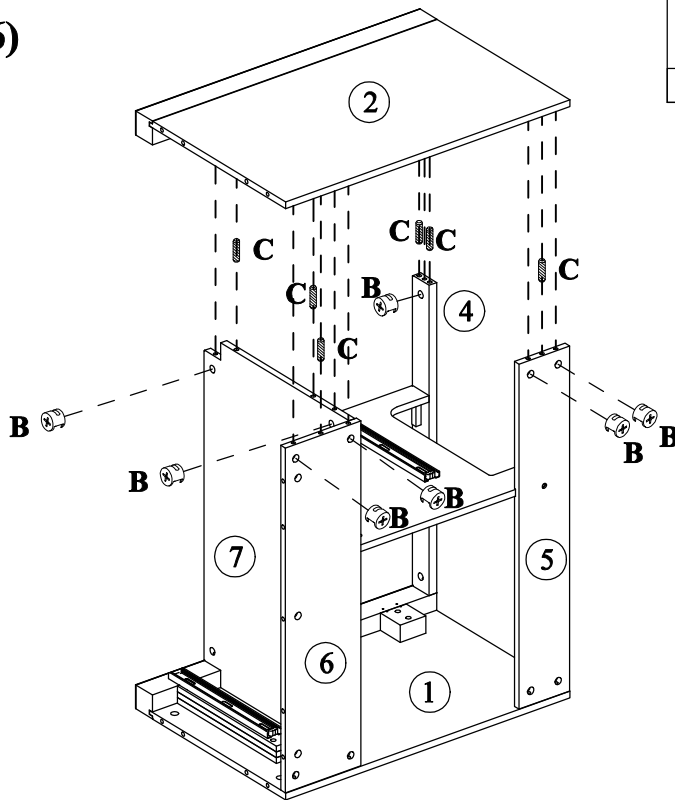

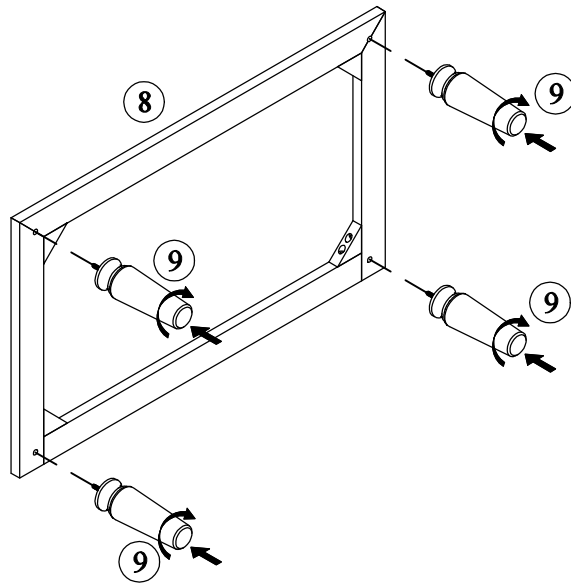

STEP: 7
(ÉTAPE: 7)

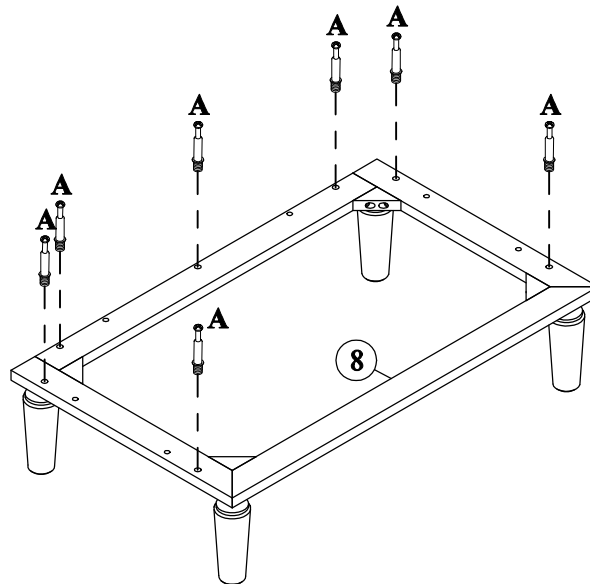
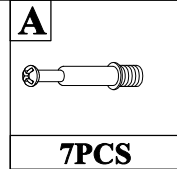

STEP: 8
(ÉTAPE: 8)



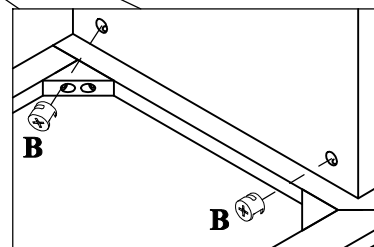
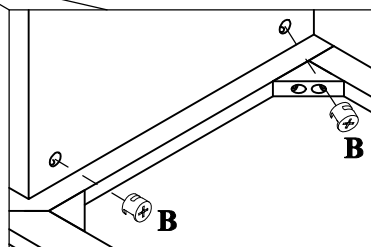
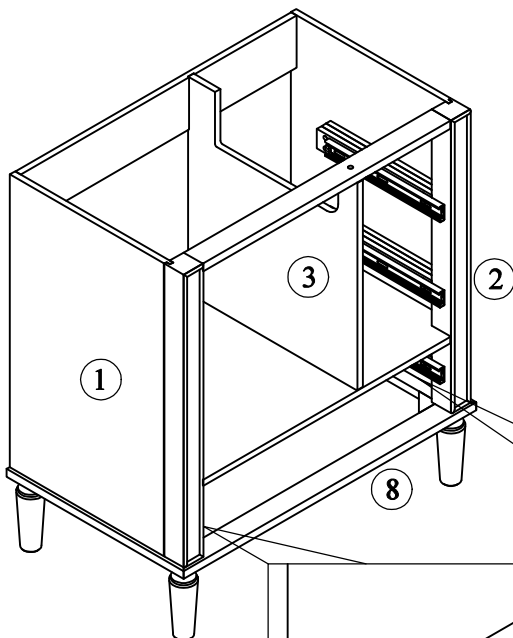
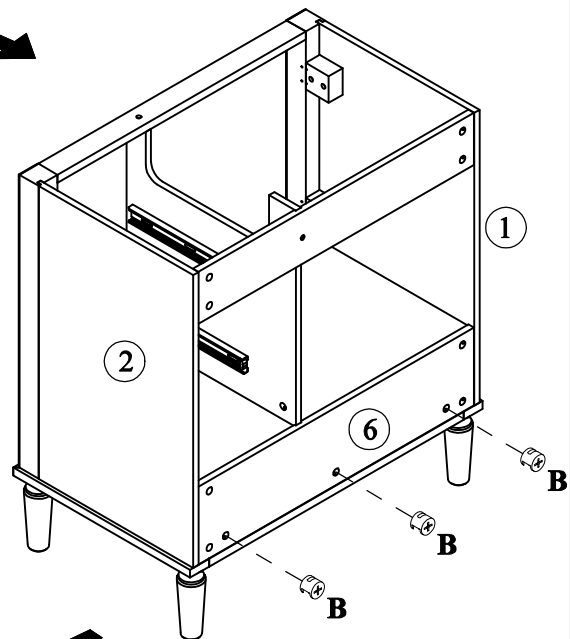
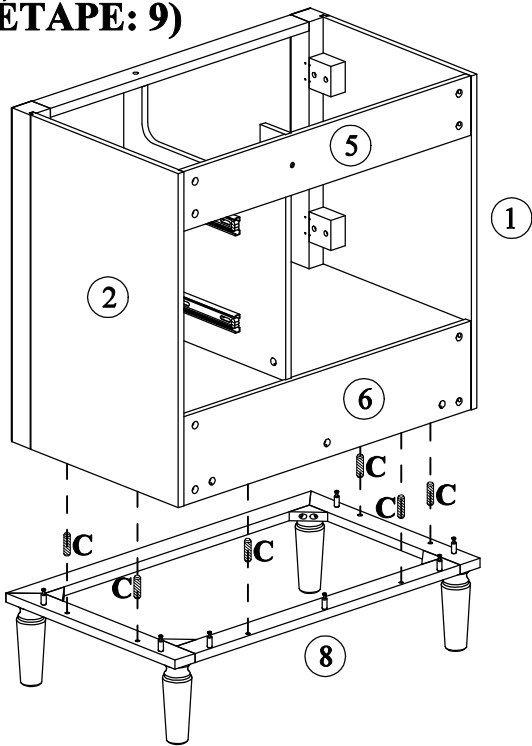

STEP: 9
(ÉTAPE: 9)

B		C	
	7PCS		6PCS



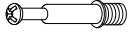

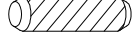
STEP: 10
(ÉTAPE: 10)

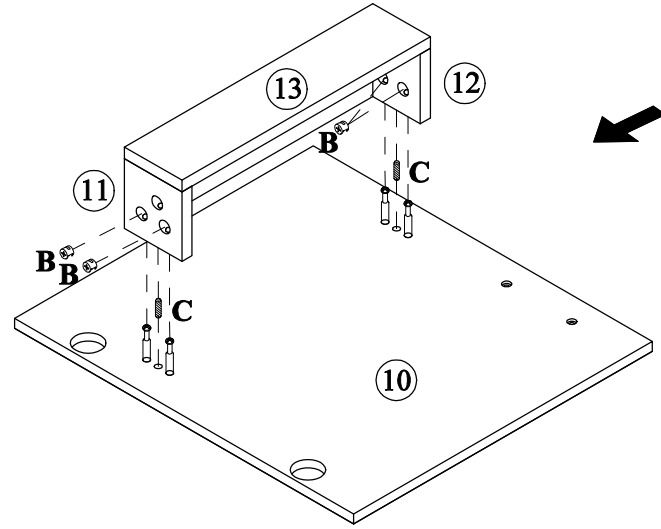
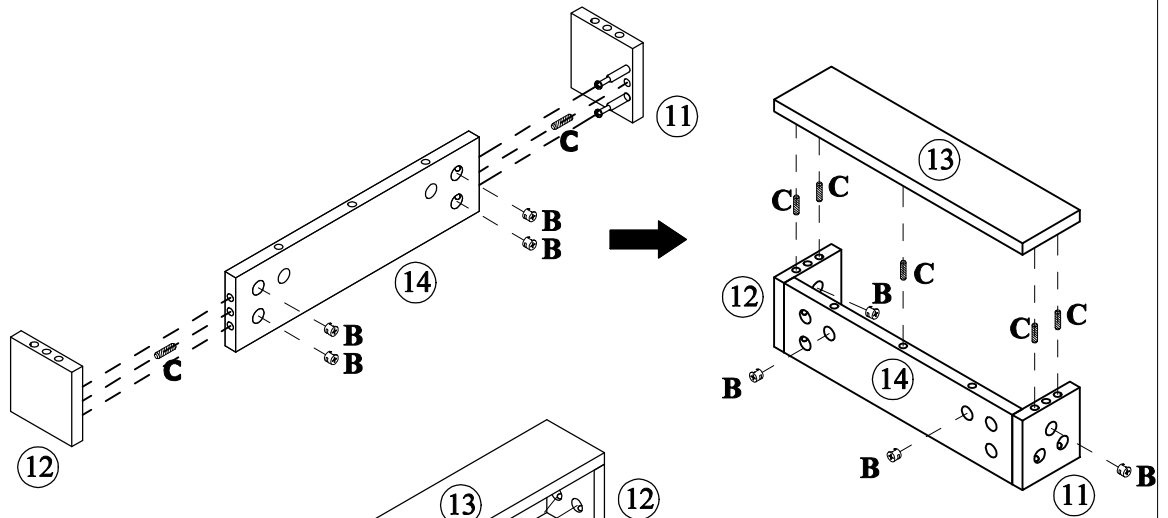
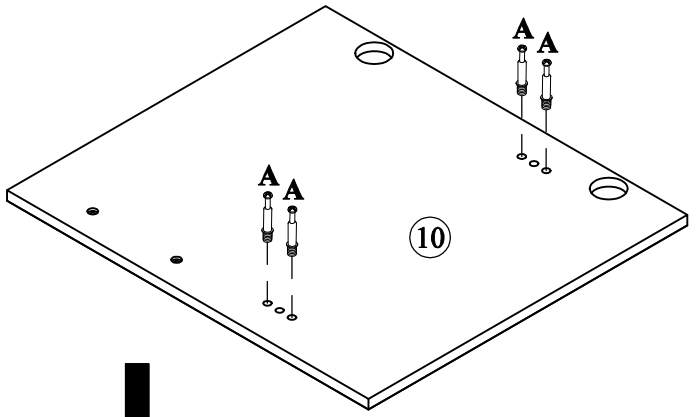
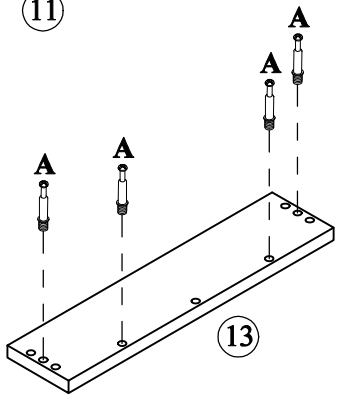
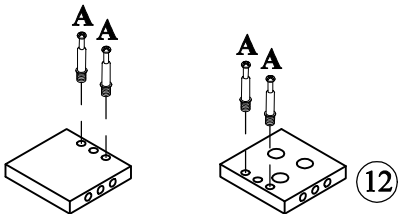
A	B	C
		
12PCS	12PCS	9PCS



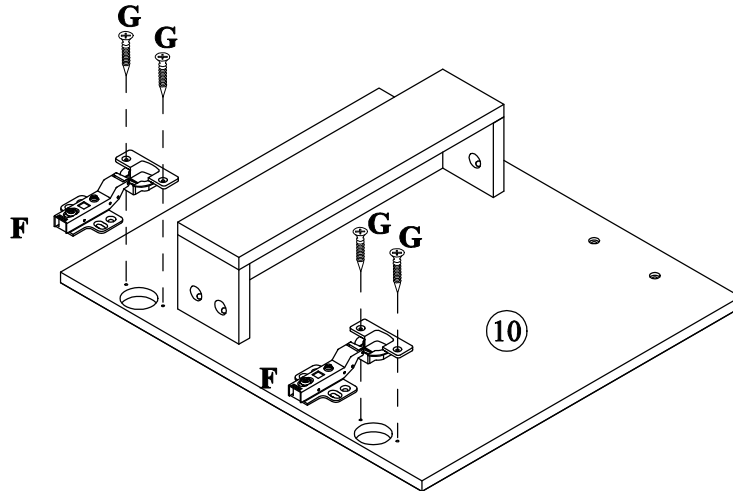

STEP: 11
(ÉTAPE: 11)

F 	G 
2PCS	4PCS



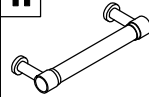

STEP: 12
(ÉTAPE: 12)

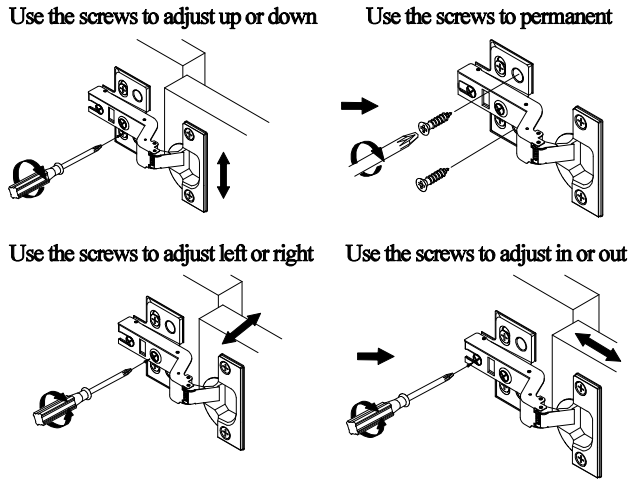
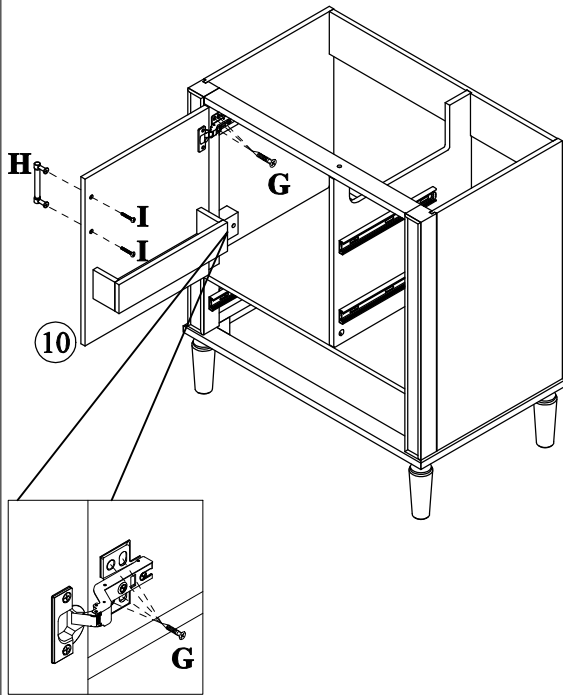
G 	H 	I 
8PCS	1PC	2PCS

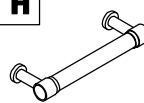

STEP: 13
(ÉTAPE: 13)

E	H	I	J
			
8PCS	2PCS	2PCS	2PCS

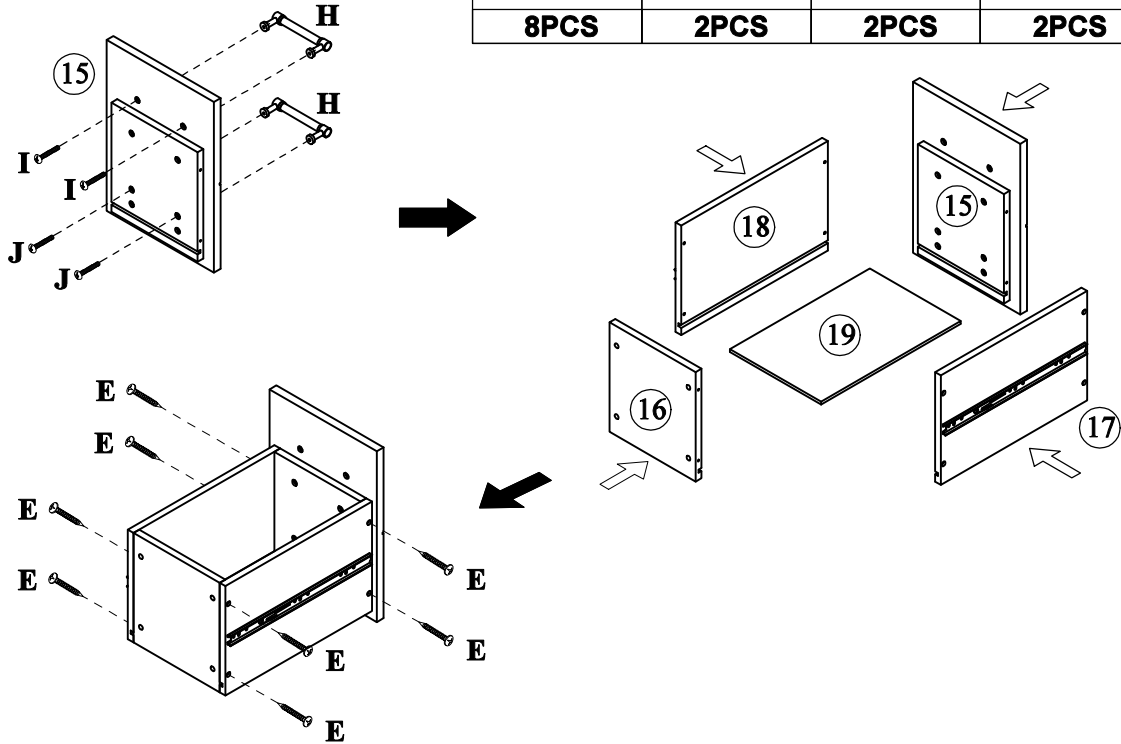

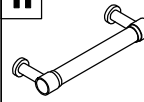
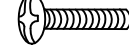

STEP: 14
(ÉTAPE: 14)

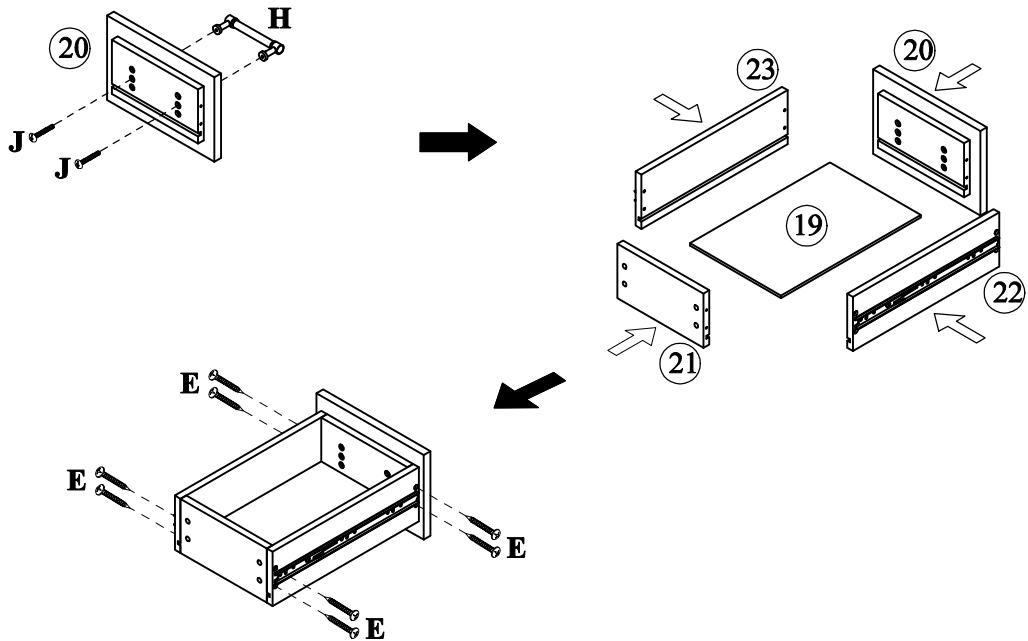
E	H	J
		
8PCS	1PC	2PCS

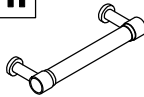

STEP: 15
(ÉTAPE: 15)

E	H	J
		
8PCS	1PC	2PCS

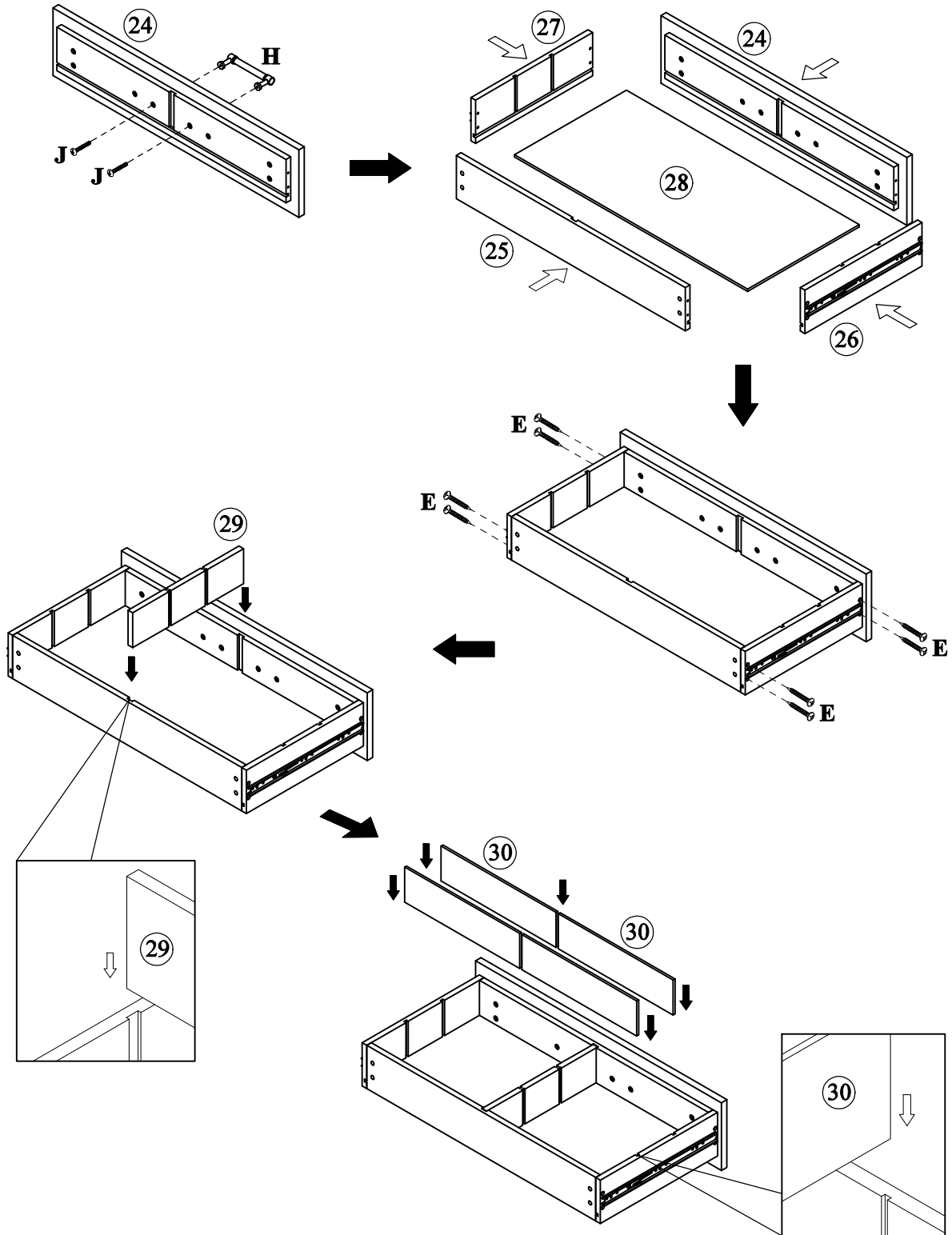

STEP: 16
(ÉTAPE: 16)

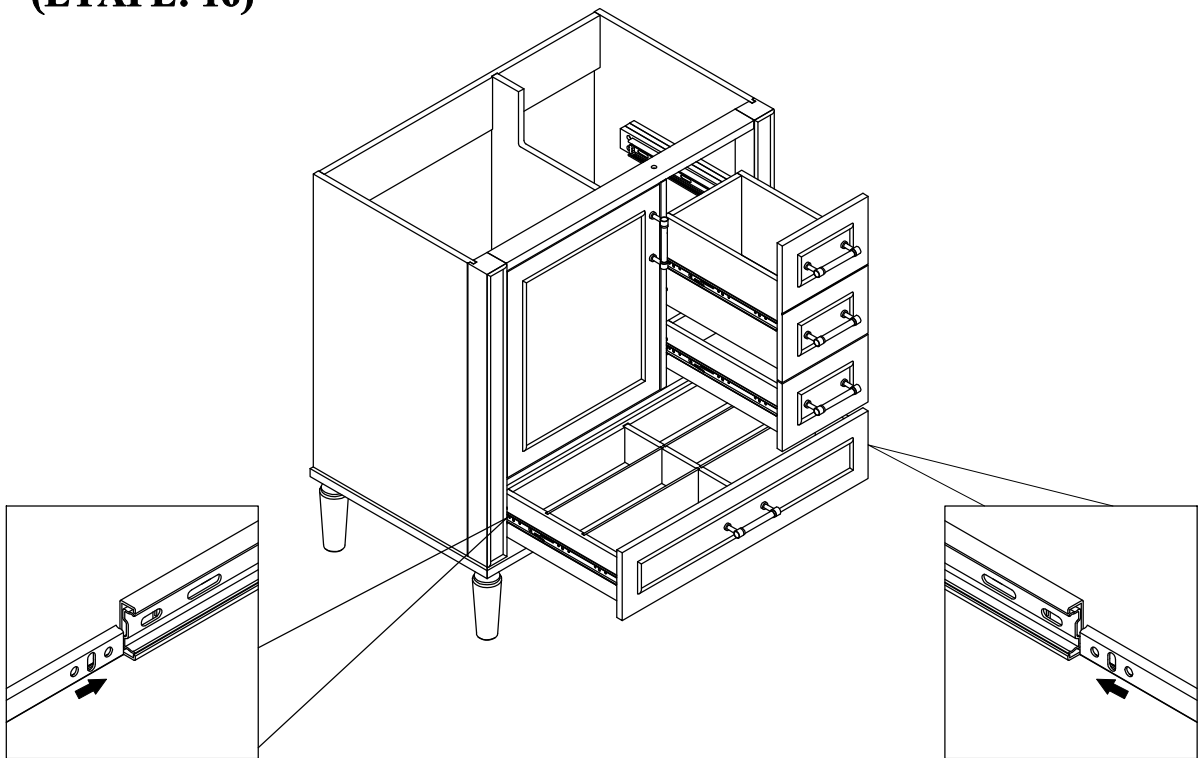

STEP: 17
(ÉTAPE: 17)

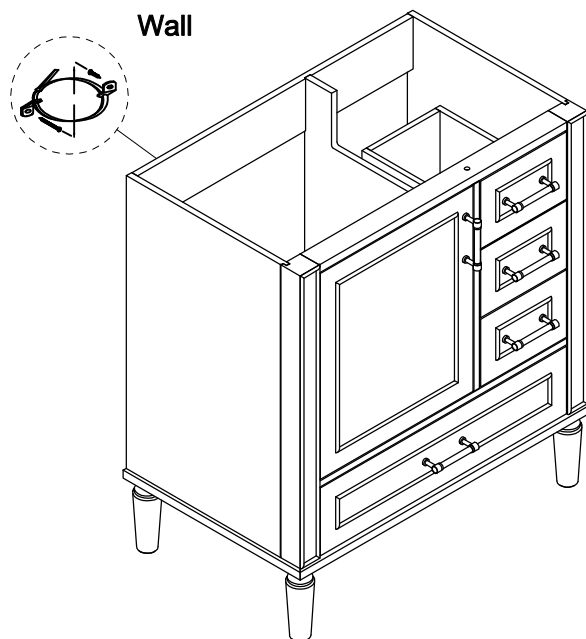
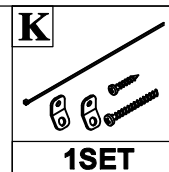

STEP: 18

(ÉTAPE: 18)

Install the sink on the cabinet with glue. Let stand for 24 hours
(Installez l'évier sur le meuble avec de la colle. Laissez reposer 24 heures)

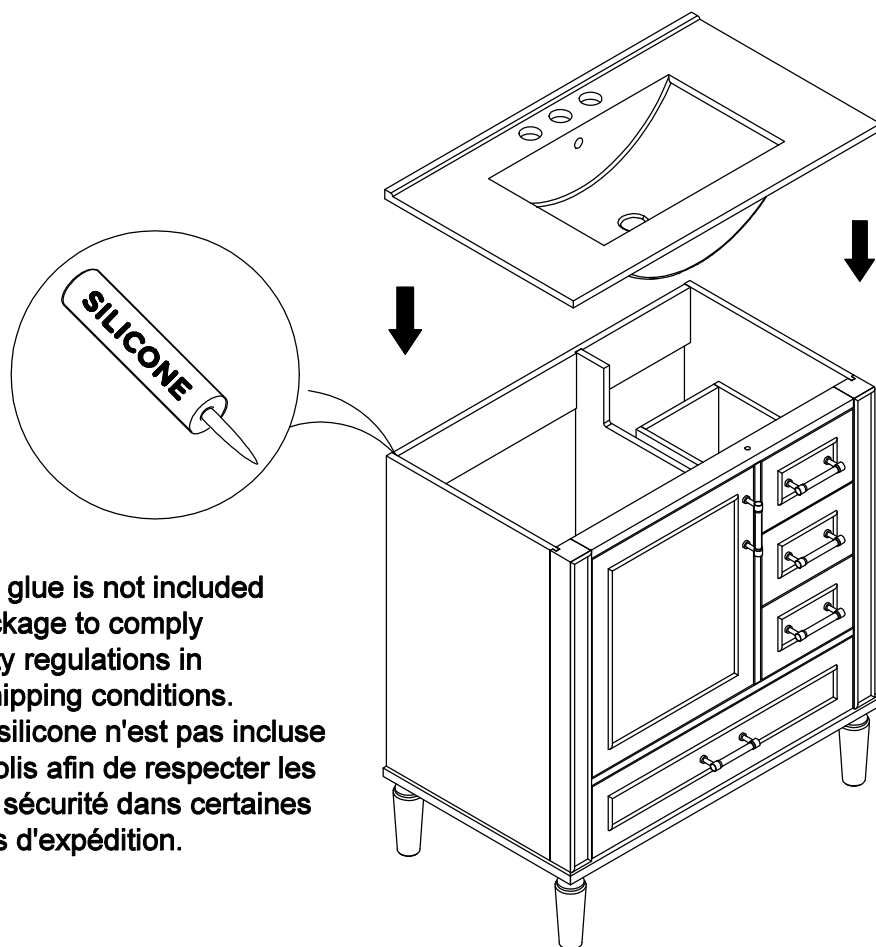

*Silicone glue is not included
in the package to comply
with safety regulations in
certain shipping conditions.

*La colle silicone n'est pas incluse
dans le colis afin de respecter les
règles de sécurité dans certaines
conditions d'expédition.

STEP: 19
(ÉTAPE: 19)

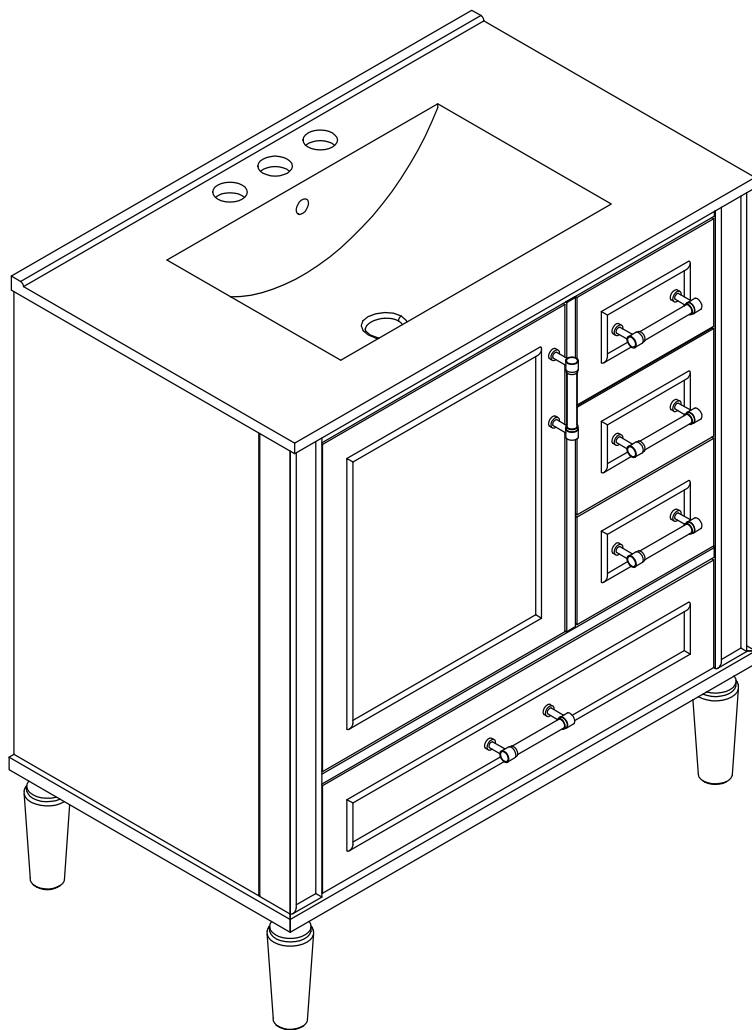

HINGE ADJUSTMENTS

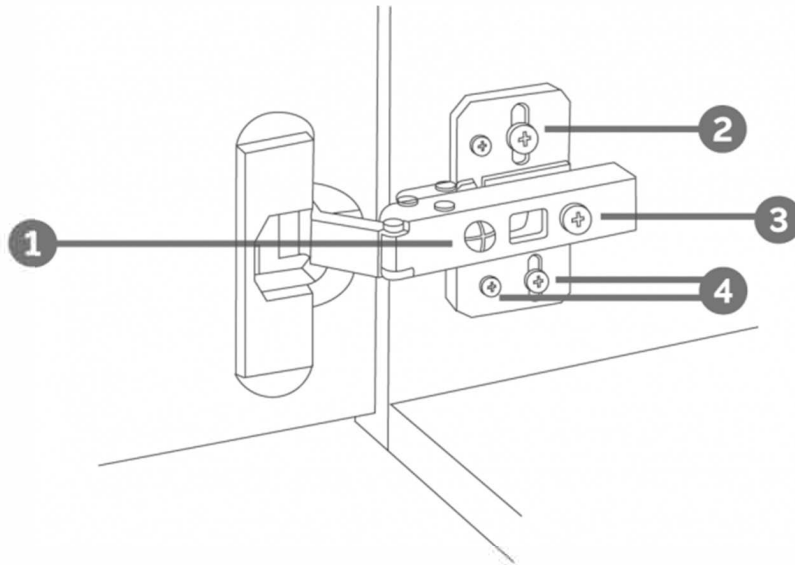

1 Sideways / Tilt adjustment

Turn the screw
clockwise to move the door further away from
the side of the cabinet
anticlockwise to move the door closer to the
side of the cabinet

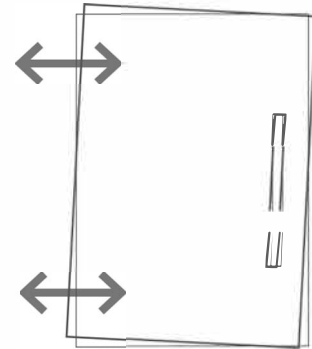

2 4 Height adjustment

While supporting the weight of the door, turn the
screws
clockwise to move the door up
anticlockwise to move the door down

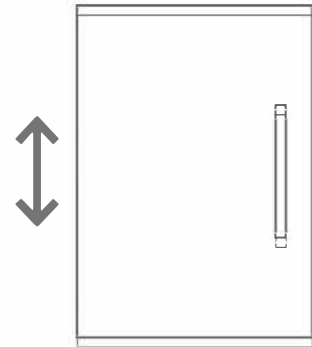

3 Forward and back adjustment

If the gap between the back of the door and the
cabinet is too small, and the door may not close
fully. Turn the screw
clockwise to decrease the gap between the
door and the cabinet
anticlockwise to increase the gap between the
door and the cabinet

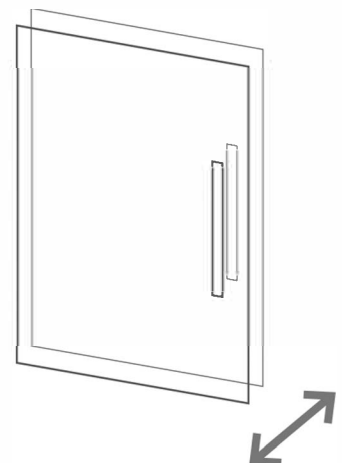

RÉGLAGES DES CHARNIÈRES

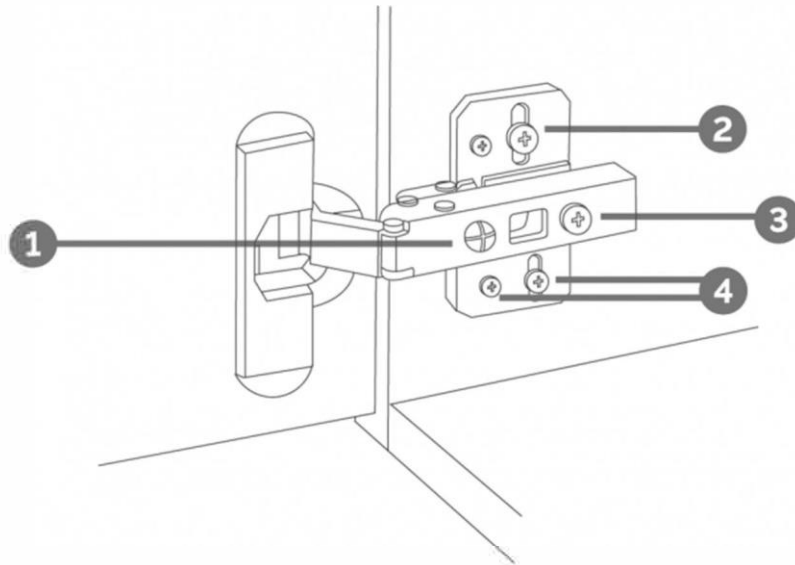

❶ De côté / Réglage de l'inclinaison

Tournez la vis dans le sens des aiguilles d'une montre pour éloigner la porte le côté du meuble
dans le sens inverse des aiguilles d'une montre pour rapprocher la porte du côté du meuble

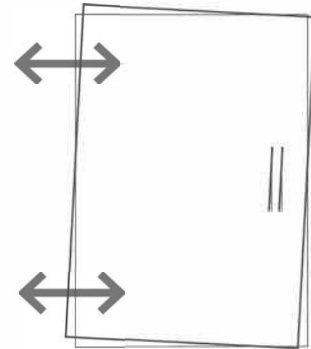

❷ ❹ Réglage de la

Tout en supportant le poids de la porte, tournez les vis dans le sens des aiguilles d'une montre pour déplacer la porte vers le haut
dans le sens inverse des aiguilles d'une montre pour abaisser la porte

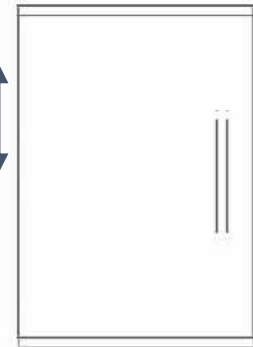

❸ Réglage vers l'avant et vers l'arrière

Si l'espace entre l'arrière de la porte et le l'armoire est trop petite et la porte risque de ne pas se fermer complètement. Tournez la vis dans le sens des aiguilles d'une montre pour diminuer l'écart entre la porte et l'armoire
dans le sens inverse des aiguilles d'une montre pour augmenter l'écart entre la porte et l'armoire.

