

Assembly Instructions
Instrucciones De Ensamblaje
Instructions D'Assemblage



Please mention model # BL090Y20007_V1



877-472-4296

www.medalsports.com

LIMITED 90 DAYS WARRANTY

This product is covered by a limited warranty that is effective for 90 days from the date of purchase. If, during the limited warranty period, a part is found to be defective or breaks, we will offer replacement parts at no cost to you, the customer. The only exceptions to the warranty include mainframes, table tops, playing surfaces, batteries or tools.

The above warranty will not apply in cases of damages due to improper usage, alteration, misuse, abuse, accidental damage or neglect.

This Limited Warranty gives you specific legal rights and you may also have other rights vary from one State (province) to another.

A PURCHASE RECEIPT (or other proof of purchase) will be required before any warranty service is initiated. For all requests for warranty service, please feel free to contact our Consumer Service Department.

Please be aware of your product's Limited Warranty for the return/refund policy from the store. We, at Medal Sports, cannot handle the product which is out of product's limited warranty since we only provide available parts. Thank you!

PLEASE CONTACT US BEFORE RETURNING THE PRODUCT TO THE STORE!

GARANTÍA LIMITA DE 90 DIAS

Este producto está cubierto por una garantía efectiva de 90 días a partir de la fecha de su compra. Durante el período límite de la garantía, si una parte defectuosa o quebrada es encontrada, nosotros ofreceremos una reparación o un reemplazo de la partes sin ningún costo para ud, nuestro cliente. Las únicas excepciones de la garantía incluyen unidad principales, tableros de mesa, superficies, pilas o herramientas.

La susodicha garantía no se aplicará en los casos de daños y perjuicios debido al uso impropio, la alteración, el mal uso, el abuso, el daño accidental o la negligencia.

Esta garantía limitada le da a usted derechos legales específicos, usted también puede tener otros derechos que varían de un estado (provincia) a otro.

EL RECIBO DE LA COMPRA (U otra prueba de compra) sería requerida antes que cualquier servicio de garantía fuera iniciada. Para todo pedido por servicio de garantía, por favor siéntase libre de ponerse en contacto con nuestro Departamento de Servicio de Consumidor.

Por favor tenga atención sobre el Límite de Garantía de su producto de la política de vuelta/reembolsa desde la tienda. Nosotros, Medal Sports, no podemos manejar el producto que está fuera del límite de garantía ya que proporcionamos solamente partes disponibles. ¡Gracias!

¡POR FAVOR PÓNGASE EN CONTACTO CON NOSOTROS ANTES DE DEVOLVER EL PRODUCTO A LA TIENDA!

GARANTIE LIMITEE DE 90 JOURS

Ce produit est couvert par une garantie limitée valable 90 jours à compter de la date d'achat. Si pendant cette période une pièce est jugée défectueuse ou se casse, nous la remplacerons gratuitement. Les seules exceptions à la garantie comprennent les armatures principales, les dessus de table, les surfaces de jeu, les piles ou les outils.

La garantie ci-dessus ne s'applique pas en cas de dommages occasionnés par une mauvaise utilisation, une altération du produit, de mauvais traitements, des dommages accidentels ou des négligences.

Cette garantie limitée vous accorde des droits légaux spécifiques ainsi que d'autres droits variant d'un état (province) à un autre.

UNE FACTURE D'ACHAT (ou toute autre preuve d'achat) sera exigée avant toute intervention sous garantie. Pour toute demande d'intervention sous garantie, veuillez contacter notre Service à la Clientèle.

Comprenez notre garantie produit limitée en ce qui concerne notre politique de retour/remboursement depuis votre magasin. Ici à Medal Sports, nous ne pouvons prendre un compte un produit qui n'est plus sous garantie puisque nous ne pouvons que fournir les pièces disponibles. Remerciements!

VEUILLEZ NOUS CONTACTER AVANT DE RETOURNER LE PRODUIT EN MAGASIN!



WE ARE READY TO HELP

DO NOT RETURN TO STORE

ESTAMOS LISTOS PARA AYUDAR

NO DEVOLVERLO A LA TIENDA

NOUS SOMMES PRÊTS À VOUS AIDER

NE PAS RAPPORTER EN MAGASIN

Please Contact | Por favor Contacto | Veuillez contacter

MD SPORTS

Customer Service
Toll Free

Servicio al Cliente
Llamados gratuitos

Service Clientèle
N° Vert

877-472-4296

Mon.-Fri.,
9:00 a.m. to 5:00 p.m. EST

Lunes a Viernes,
9:00 a.m. a 5:00 p.m. ET

Du lundi au vendredi de
9:00 a 17 heures HNE

For additional resources and
Frequently Asked Questions,
please visit us at

Por mayor información y
Preguntas Frecuentes, favor
visitarnos en

Pour toute information
complémentaire ou réponse
aux questions fréquentes,
veuillez vous rendre sur

www.medalsports.com

TOOLS REQUIRED

Phillips Screwdriver - **Not Included**
Standard (Flat Head) - **Not Included**
Screwdriver)
Wrench - **Included**

HERRAMIENTAS NECESARIAS

Destornillador Phillips - **No incluido**
Destornillador de
Cabeza Plana
Llave Inglesa - **Incluido**

OUTILS REQUIS

Tournevis cruciforme - **Non inclus**
Tournevis standard - **Non inclus**
(Tête plate)
Clé anglaise - **Incluse**

 **RECOMMENDED**

Electric Screwdrivers may be helpful during assembly; however, please set a low torque and use extreme caution.

 **RECOMENDADO**

Los destornilladores eléctricos pueden ser de gran ayuda durante el ensamblado; sin embargo, por favor ajuste el par de giro bajo y sea extremadamente precavido.

 **RECOMMANDÉ**

Un tournevis électrique peut être utile pour l'assemblage; utilisez cependant une vitesse de rotation lente et avec prudence.



Power Tools: **Set to Low Torque**
/Herramientas eléctricas: **Establecer bajo par de torsión**
/Visseuse électrique: **Couple faible**



High Torque Over Tightened
/ Alto par más estrictas
/ Un couple élevé peut créer des dommages

 **IMPORTANT NOTICE**

1. This product is intended for INDOOR use only.
2. Please do not sit, climb or lean on the product.
3. Please do not drag the product when moving it in order to avoid damaging the legs.
4. Please only use spray furniture polish to clean the exterior surfaces of the product.
5. This is not a children's toy, adult supervision is required for children playing this game.

AVISO IMPORTANTE

1. Este producto está destinado para el uso INTERIOR solamente.
2. Por favor no sientes, subas o inclínes el producto.
3. Por favor no arrastres el producto cuando está moviendo para evitar el daño sobre las piernas.
4. Por favor use solamente spray para muebles para limpiar la superficie exterior del producto.
5. Este no es un juguete para niños, se requieren la supervisión adulta para niños cuando esté jugando al juego.

 **NOTE IMPORTANTE**

1. Ce produit est conçu pour une utilisation en intérieur uniquement.
2. Veuillez ne pas vous asseoir, grimper ou vous appuyer sur la produit.
3. Veuillez ne pas déplacer la produit en la tirant pour ne pas endommager les pieds.
4. Veuillez utiliser seulement un produit nettoyant pour meubles pour nettoyer les surfaces extérieures de la produit de jeu.
5. Ce n'est pas un jeu d'enfant et la surveillance d'adultes est requise pour les enfants qui jouent ce jeu.



At least 4 adults needed
Se necesitan al menos 4 adultos
Il faut au moins 4 adultes



No children in assembly area
No deben estar los niños en el area de ensamble
Pas d'enfants dans la zone d'assemblage



Keep away from pets in assembly area
Mantener alejados a los animales domesticos del area de ensamble
Tenir les animaux de compagnie à distance



Do not use or keep product outdoors. For indoor use only. No wet/humid conditions.
No usar o guardar el producto en el exterior. Solo para uso en interior. No utilizar ni guardar el producto en lugares humedos o mojados

N'utilisez ni ne stockez ce produit en extérieur. Uniquement pour utilisation en intérieur. Ne pas exposer à l'humidité

 **WARNING**

Adult assembly required.
CHOKING HAZARD - This item contains small parts. Not suitable for children under 3 years.

 **ADVERTENCIA**

El ensamblaje debe ser realizado por un adulto.
PELIGRO DE ASFIXIA - Este artículo contiene piezas pequeñas. No es apto para niños menores de 3 años de edad.

 **ATTENTION**

L'assemblage doit être effectué par des adultes.
RISQUE D'ASPHYXIE - Ce produit contient de petites pièces. Ne convient pas à des enfants de moins de 3 ans.

PARTS IDENTIFIER

IDENTIFICADOR DE PIEZAS

IDENTIFICATEUR DE PIÈCES

PART NUMBER
NÚMERO DE PIEZA
NUMÉRO D'ARTICLEPART
PIEZA
PIÈCE

PART NAME

1

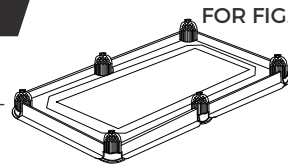

FOR FIG. 14

x1

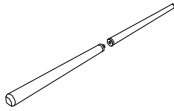

FIG NUMBER
NÚMERO DE FIG
NUMÉRO FIGQUANTITY
CANTIDAD
QUANTITÉNOM DE LA PIÈCE
NOMBRE DE PIEZAMainframe
Unidad principal
Unité centrale

2 FOR FIG. 7 x2 Lower Side Apron Delantal lateral inferior Tablier latéral inférieur	3 FOR FIG. 7 x2 Lower End Apron Faldón del extremo Tablier d'extrémité inférieur	4 FOR FIG. 2 x4 Leg Panel Support Soporte de panel de pierna Panneau de support de pied	5 FOR FIG. 1 x4 Leg Top Panel - A Panel superior de pierna - A Panneau pied supérieur - A
6 FOR FIG. 1 x4 Leg Top Panel - B Panel superior de pierna - B Panneau pied supérieur - B	7 FOR FIG. 3 x4 Plastic Leg - A Pata plástica - A Pied en plastique - A	8 FOR FIG. 3 x4 Plastic Leg - B Pata plástica - B Pied en plastique - B	9 FOR FIG. 5 x4 Plastic Leg - C Pata plástica - C Pied en plastique - C
10 FOR FIG. 4 x4 Plastic Leg - D Pata plástica - D Pied en plastique - D	11 FOR FIG. 4 x4 Plastic Leg - E Pata plástica - E Pied en plastique - E	12 FOR FIG. 8 x4 Apron Corner Delantal de rincón Tablier de coin	13 FOR FIG. 2 x8 L Bracket Corchete "L" Patte de fixation en "L"
14 FOR FIG. 11 x4 Leg Base Base de pata Base pied	15 FOR FIG. 10 x4 Leg Top Panel Panel superior de pierna Panneau pied supérieur	16 FOR FIG. 13 x2 Support Board Tablero de soporte Barre de support	17 FOR FIG. 7 x2 Side Top Board Tablero superior lateral Panneau supérieur latéral
18 FOR FIG. 7 x2 End Top Board Tablero superior final Panneau supérieur final	19 FOR FIG. 12 x4 Leg Leveler Nivelador de pata Niveleur de pied	20 FOR FIG. 7 x1 Glue Pegamento Colle	21 FOR FIG. 13 x2 Adjustable Bracket Corchete regulable Support réglable
22 FOR FIG. 15 x2 Cue Rack - Side Panel Estante de tectos-panel lateral Support de queue de billard -panneau latéral	23 FOR FIG. 15 x2 Cue Rack - Middle Shelf Estante de tectos-repisa de en medio Support de queue de billard -tablette du milieu	24 FOR FIG. 16 x1 Cue Rack - Base Panel Estante de tectos-panel de base Support de queue de billard -panneau inférieur	25 FOR FIG. 16 x1 Cue Rack - Top Panel Estante de tectos-panel superior Support de queue de billard -panneau supérieur
26 FOR FIG. 18 x2 Hook Gancho Crochet	27 FOR FIG. 18 x1 Triangle Holder Sujetador de triángulo Support triangle	28 FOR FIG. 17 x2 Cue Holder Sujetador de tacos Attache-queues	

ACCESSORIES

ACCESORIOS



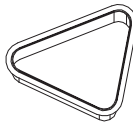
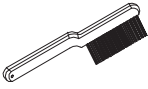
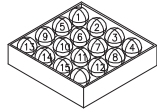



ACCESSOIRES

29  x2			30  x2			31  x1			32  x1		
Cue	Taco	Queue de billard	Chalk	Tiza	Craie	Triangle	Triángulo	Triangle	Brush	Cepillo	Brosse
33  x1											
Billiard Ball Set	Bola de billar	Ensemble boules de billard									

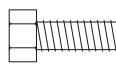
HARDWARE

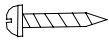
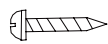
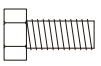
HARDWARE

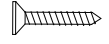
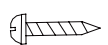
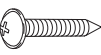
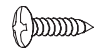
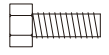
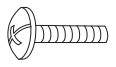
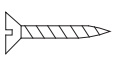
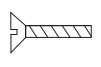
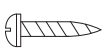

MÉTAUX

A1 FOR FIG. 2  x32			A2 FOR FIG. 2, 11  x48			A3 FOR FIG. 2  x16			A4 FOR FIG. 6, 9  x24		
M8x28mm Bolt	Perno M8x28mm	Boulon M8x28mm	M8 Spring Lock Washer	Arandela de cerradura de resorte M8	Rondelle de blocage M8	M8 Washer	Arandela M8	Rondelle M8	4x15mm Screw	Tornillo 4x15mm	Vis 4x15mm
A5 FOR FIG. 11  x8			A6 FOR FIG. 11  x16			A7 FOR FIG. 14  x18			A8 FOR FIG. 10  x8		
P3x25mm Screw	Tornillo P3x25mm	Vis P3x25mm	M8x16mm Bolt	Perno M8x16mm	Boulon M8x16mm	M6 Washer	Arandela M6	Rondelle M6	3x15mm Screw	Tornillo 3x15mm	Vis 3x15mm
A9 FOR FIG. 6  x16			A10 FOR FIG. 1, 13  x16			A11 FOR FIG. 14  x4			A12 FOR FIG. 14  x18		
P3x18mm Screw	Tornillo P3x18mm	Vis P3x18mm	4x45mm Screw	Tornillo 4x45mm	Vis 4x45mm	4x18mm Screw	Tornillo 4x18mm	Vis 4x18mm	M6x25mm Bolt	Perno M6x25mm	Boulon M6x25mm
A13 FOR FIG. 13  x4			A14 FOR FIG. 7, 15, 16  x34			A15 FOR FIG. 17  x4			A16 FOR FIG. 18  x5		
M5x25mm Bolt	Perno M5x25mm	Boulon M5x25mm	4x45mm Flat Head Screw	Tornillo de cabeza plana 4x45mm	Vis tête plate 4x45mm	3x16mm Screw	Tornillo 3x16mm	Vis 3x16mm	4x12mm Screw	Tornillo 4x12mm	Vis 4x12mm
A17  x1											
Wrench	Llave inglesa	Clé anglaise									

PRE-INSTALLED PARTS

PIEZAS PREINSTALADAS

PIÈCES PRÉINSTALLÉES

P1 FOR FIG. 1			P2 FOR FIG. 7			P3 FOR FIG. 13		
								
x16			x16			x4		
M8 T - Nut	Tuerca - T M8	Écrou en T M8	M8x10mm Nut	Tuerca M8x10mm	Écrou M8x10mm	M5 T - Nut	Tuerca - T M5	Écrou en T M5

BEFORE ASSEMBLY

ANTES DE MONTAR

AVANT L'ASSEMBLAGE

1. Find a clean, level place to begin the assembly of your product.
2. Verify that you have all listed parts as shown on the part list pages. If any parts are missing, call our customer service.

1. Encuentre un lugar limpio y nivelado para comenzar el ensamblaje del producto.
2. Compruebe que tenga todas las piezas que se muestran en la lista de piezas. Si falta alguna pieza, llame a nuestro servicio al cliente.



1. Trouvez un endroit propre et plat pour commencer à assembler votre produit.
2. Vérifiez que vous avez toutes les pièces énumérées comme indiqué sur les pages de liste des pièces. S'il y a des pièces qui manquent, appelez notre service clientèle.

ASSEMBLY

MONTAJE

ASSEMBLAGE

FIG. 1

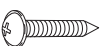
5		x4
6		x4
P1		x16
A10		x8

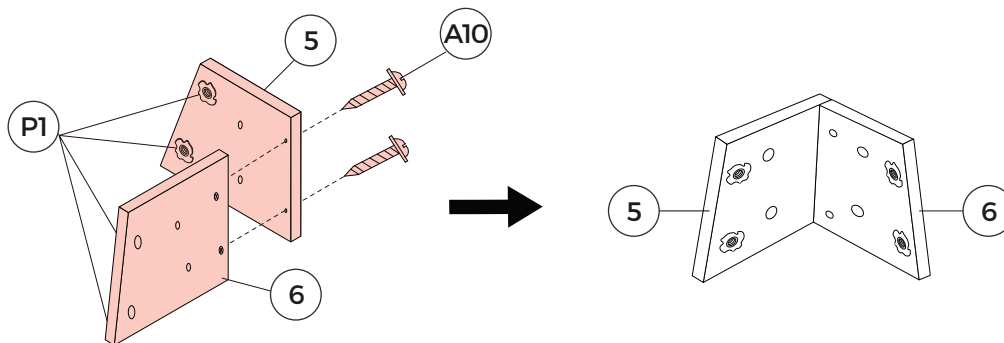





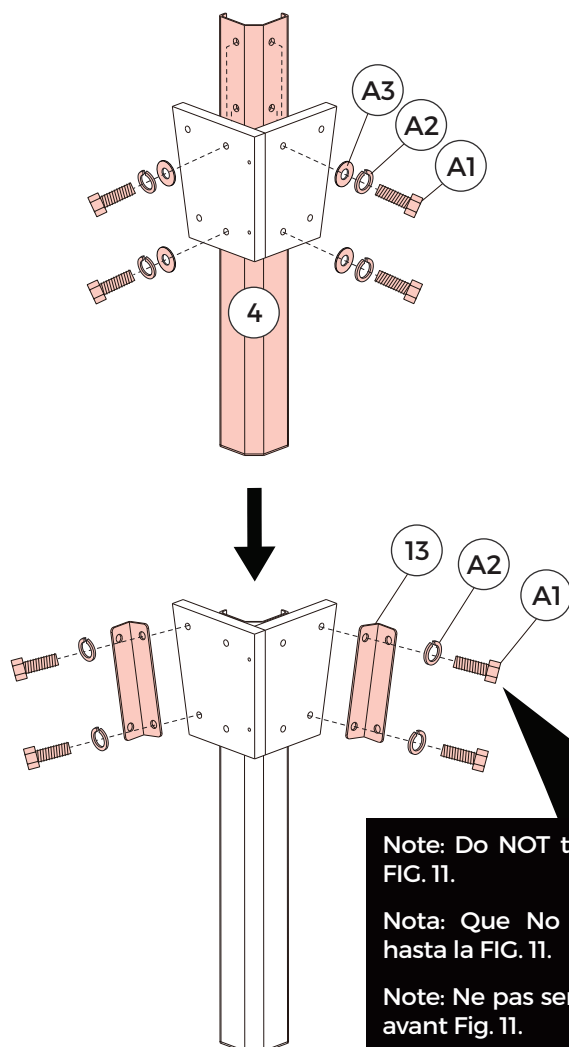

FIG. 2

4		x4
13		x8
A1		x32
A2		x32
A3		x16
A17		x1



ASSEMBLY

MONTAJE

ASSEMBLAGE

FIG. 3

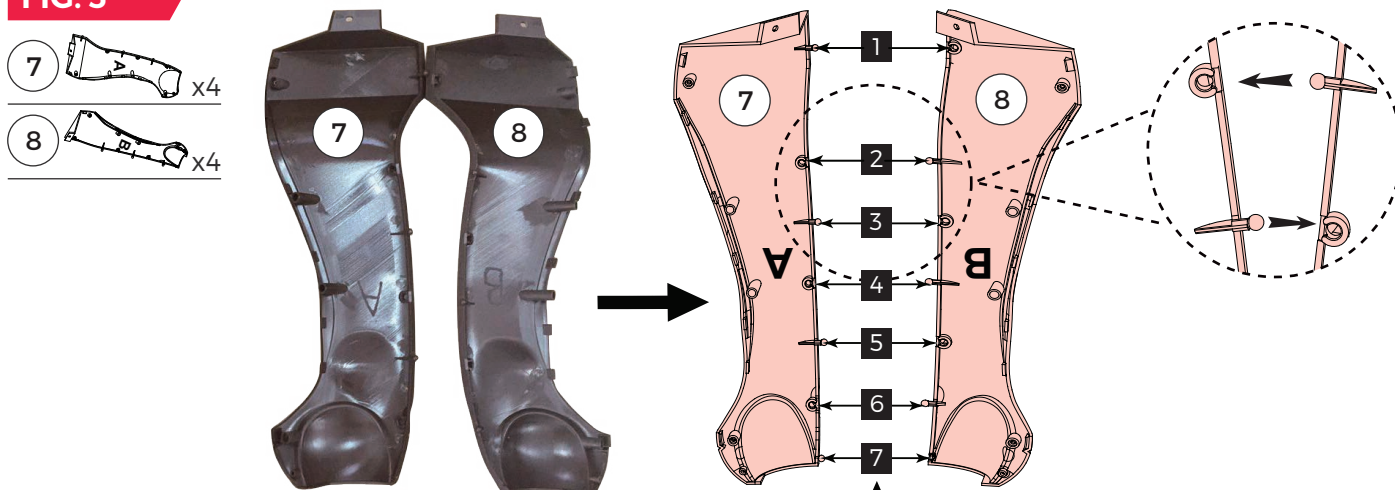

Note: For plastic legs - A, B (7 & 8), please follow the illustration and the picture accordingly, lock them together in the order of 1, 2, 3, 4, 5, 6, 7.

Nota: Para las piernas plásticas - A, B (7 y 8), siga la ilustración y la foto en consecuencia, encerrarlos en conjunto al orden de 1, 2, 3, 4, 5, 6, 7.

Note: Pour les pieds en plastique - A, B (7 & 8), veuillez suivre les indications sur le schéma et l'image. Verrouillez-les dans l'ordre suivant: 1, 2, 3, 4, 5, 6, 7.

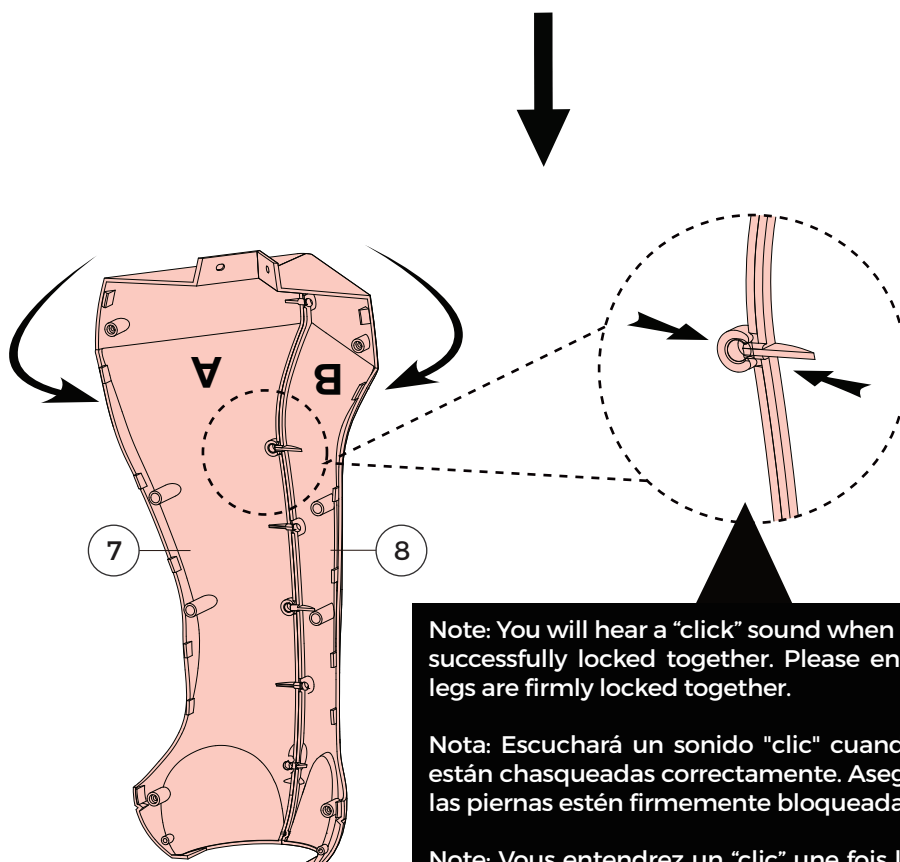

Note: You will hear a "click" sound when the legs have successfully locked together. Please ensure that the legs are firmly locked together.

Nota: Escuchará un sonido "clic" cuando las piernas están chasqueadas correctamente. Asegúrese de que las piernas estén firmemente bloqueadas.

Note: Vous entendrez un "clic" une fois les pieds bien verrouillés. Assurez-vous que les pieds sont bien verrouillés ensemble.

ASSEMBLY

MONTAJE

ASSEMBLAGE

FIG. 4

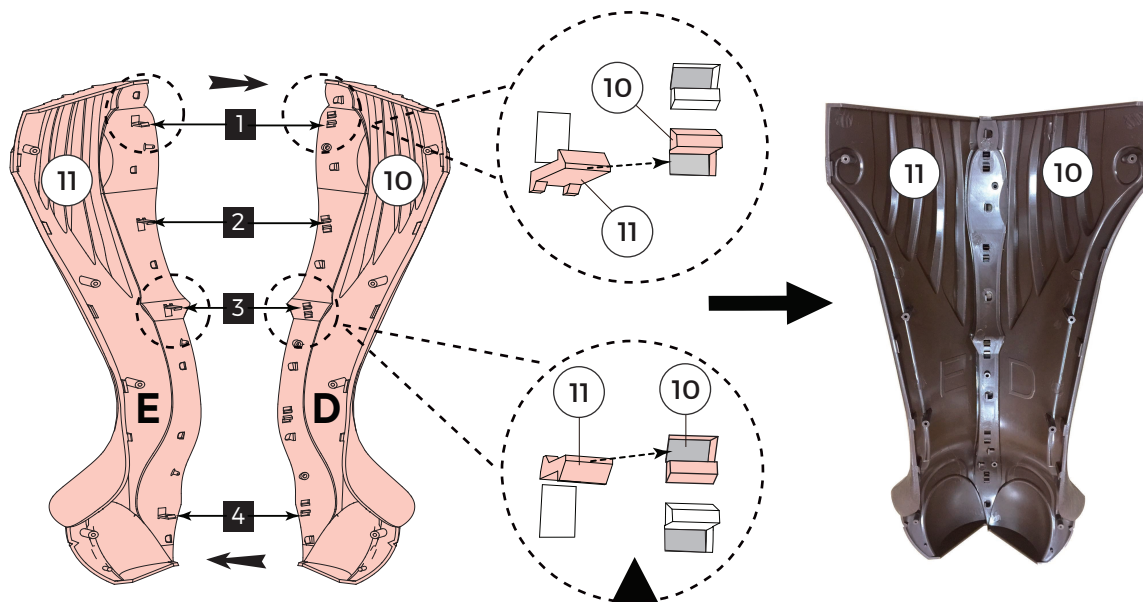
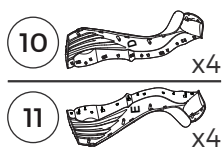

Note: For plastic legs - E, D (11 & 10), please follow the illustration and the picture accordingly, lock them together in the order of 1, 2, 3, 4.

Nota: Para las piernas plásticas - E, D (11 y 10), siga la ilustración y la foto en consecuencia, encerrarlos en conjunto al orden de 1, 2, 3, 4.

Note: Pour les pieds en plastique - E, D (11 & 10), veuillez suivre les indications sur le schéma et l'image. Verrouillez-les dans l'ordre suivant: 1, 2, 3, 4.

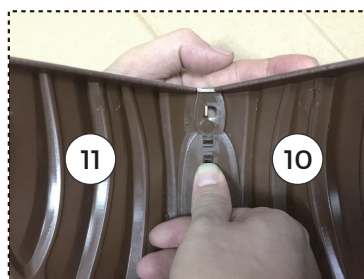
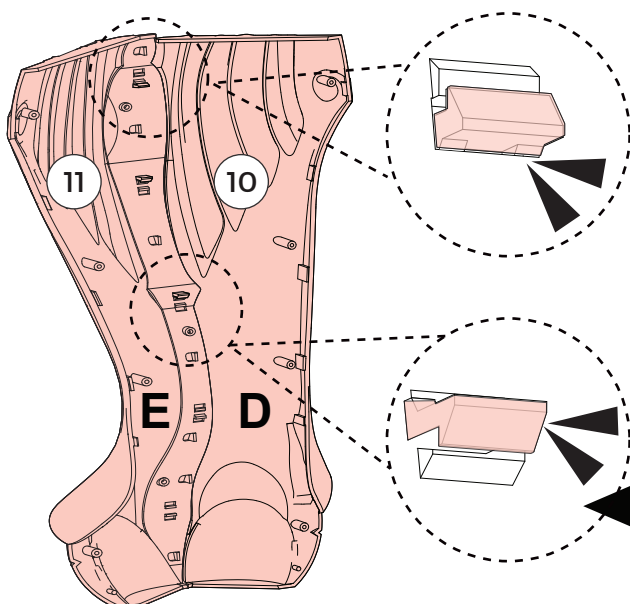

IMPORTANT: You will hear a "CLICK" sound when snapping the Legs together. This will indicate that the Legs are locked firmly in place. If you do not hear a "CLICK" sound the legs are NOT LOCKED.

IMPORTANTE: Escuchará un sonido "CLIC" cuando las piernas están chasqueadas correctamente. A esto se indicará que las Piernas están bloqueadas firmemente en su lugar. Si no oye un sonido "CLIC", las piernas NO ESTAN BLOQUEADAS.

IMPORTANT: Vous entendrez un "CLIC" en assemblant les pieds ensemble. Ceci indique que les Pieds sont bien verrouillés. Si vous n'entendez pas de « clic », les pieds NE SONT PAS verrouillés.

ASSEMBLY

MONTAJE

ASSEMBLAGE

FIG. 5



FIG. 4 Assembly
/ Ensamblaje FIG. 4
/ FIG. 4 Assemblage

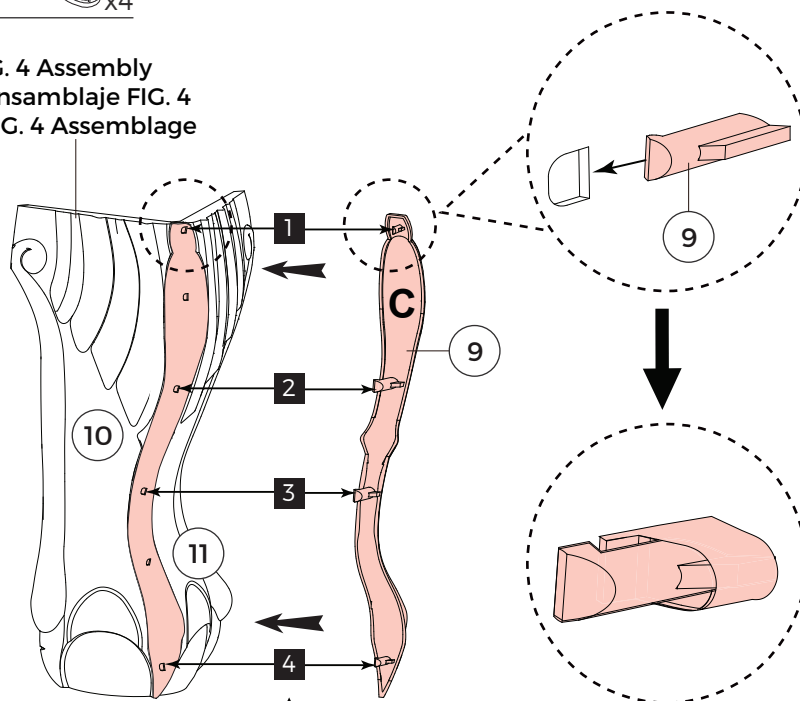

Note: For plastic legs - C (9), please follow the illustration and the picture accordingly, lock them together in the order of 1, 2, 3, 4.

Nota: Para las piernas plásticas - C (9), siga la ilustración y la foto en consecuencia, encerrarlos en conjunto al orden de 1, 2, 3, 4.

Note: Pour les pieds en plastique - C (9), veuillez suivre les indications sur le schéma et l'image. Verrouillez-les dans l'ordre suivant: 1, 2, 3, 4.



IMPORTANT: You will hear a "CLICK" sound when snapping the Legs together. This will indicate that the Legs are locked firmly in place. If you do not hear a "CLICK" sound the legs are NOT LOCKED.

IMPORTANTE: Escuchará un sonido "CLIC" cuando las piernas están chasqueadas correctamente. A esto se indicará que las Piernas están bloqueadas firmemente en su lugar. Si no oye un sonido "CLIC", las piernas NO ESTAN BLOQUEADAS.

IMPORTANT: Vous entendrez un "CLIC" en assemblant les pieds ensemble. Ceci indique que les Pieds sont bien verrouillés. Si vous n'entendez pas de « clic », les pieds NE SONT PAS verrouillés.

ASSEMBLY

MONTAJE

ASSEMBLAGE

FIG. 6

A4 x8

A9 x16

FIG. 2 Assembly / Ensamblaje FIG. 2 / FIG. 2 Assemblage

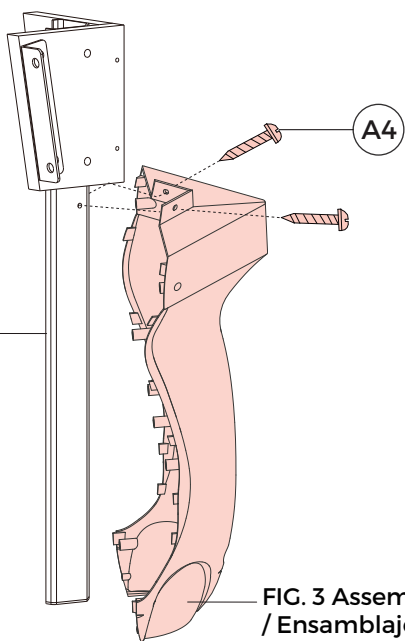

FIG. 3 Assembly / Ensamblaje FIG. 3 / FIG. 3 Assemblage

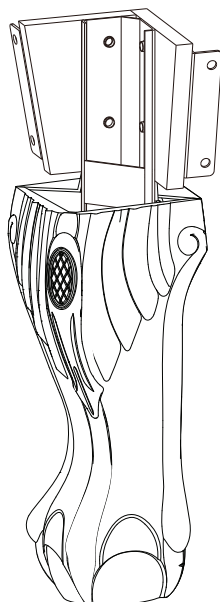
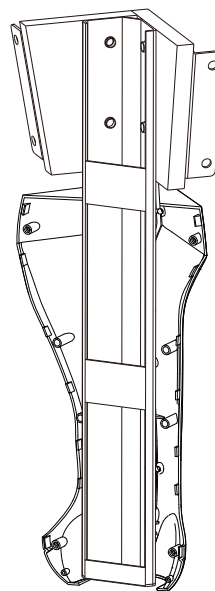
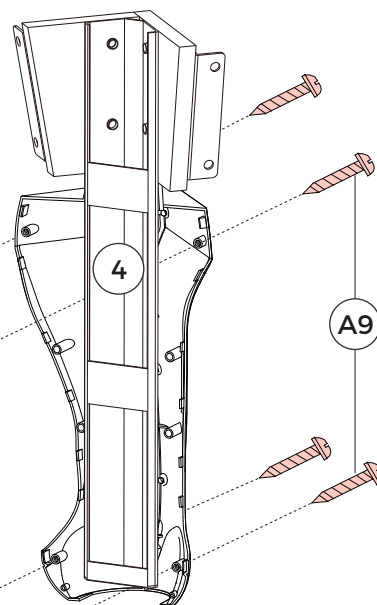
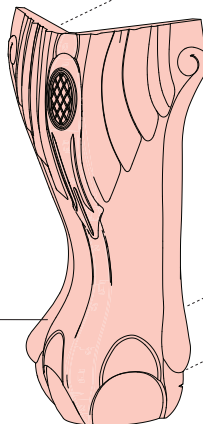

FIG. 5 Assembly / Ensamblaje FIG. 5 / FIG. 5 Assemblage





ASSEMBLY

MONTAJE

ASSEMBLAGE

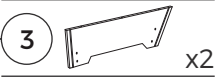
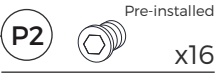
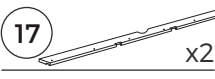
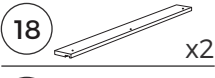
FIG. 7

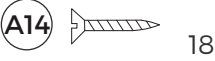
-  2 x2
-  3 x2
-  P2 Pre-installed x16
-  17 x2
-  18 x2
-  20 x1
-  A14 18

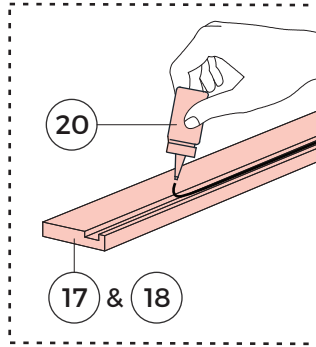

Note: Apply the Glue (20) onto the grooves of the Side and End Top Boards (17 & 18).

Nota: Aplicar el Pegamento (20) en las ranuras de las Tablas Lateral y Tablero Superior Lateral (17 & 18).

Note: Appliquez de la colle (20) dans les rainures des Panneaux Supérieurs Latéral et Final (17 & 18).

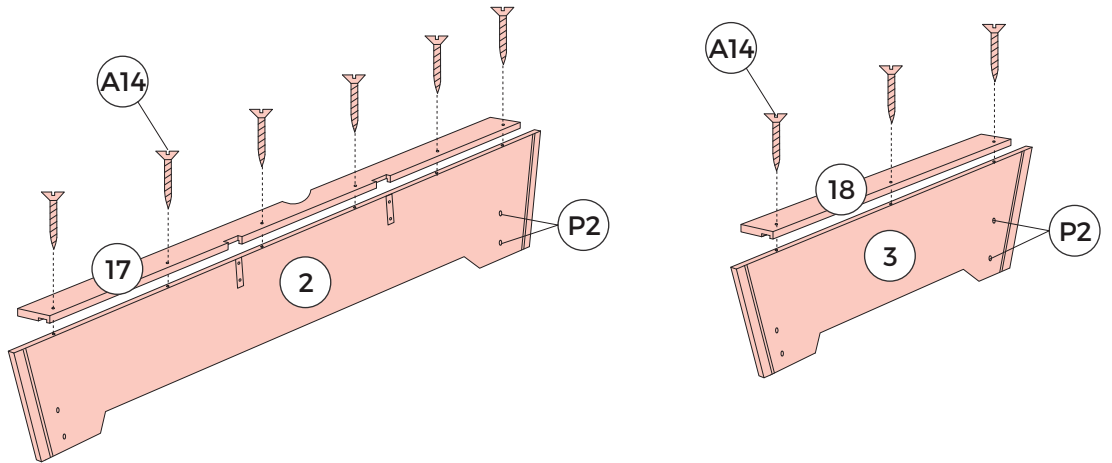
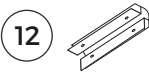
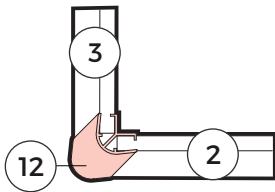

FIG. 8

-  12 x4

TOP VIEW: Part 12
/ VISTA SUPERIOR: Parte 12
/ VUE DU DESSUS: Part 12



SIDE VIEW: Part 12
/ VISTA LATERAL: Parte 12
/ VUE LATÉRALE: Part 12

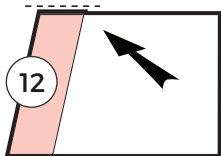

Note: Flush with Aprons
/ Nota: Alineado con Delantar
/ Note: Alignement des Tabliers

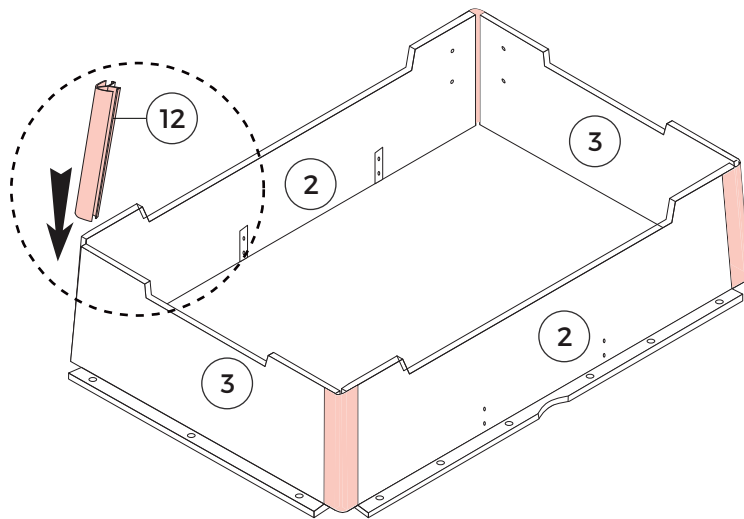

Note: Arrow on the backside of Apron Corners shows direction to slide the Apron Corners down.

Nota: La flecha sobre la parte trasera de la Abrazadera de esquina muestra la dirección para deslizar la Abrazadera de esquina hacia abajo.

Note: La flèche à l'arrière des Coins de Tablier montre la direction pour faire coulisser les Coins De Tablier vers le bas.

ASSEMBLY

MONTAJE

ASSEMBLAGE

FIG. 9

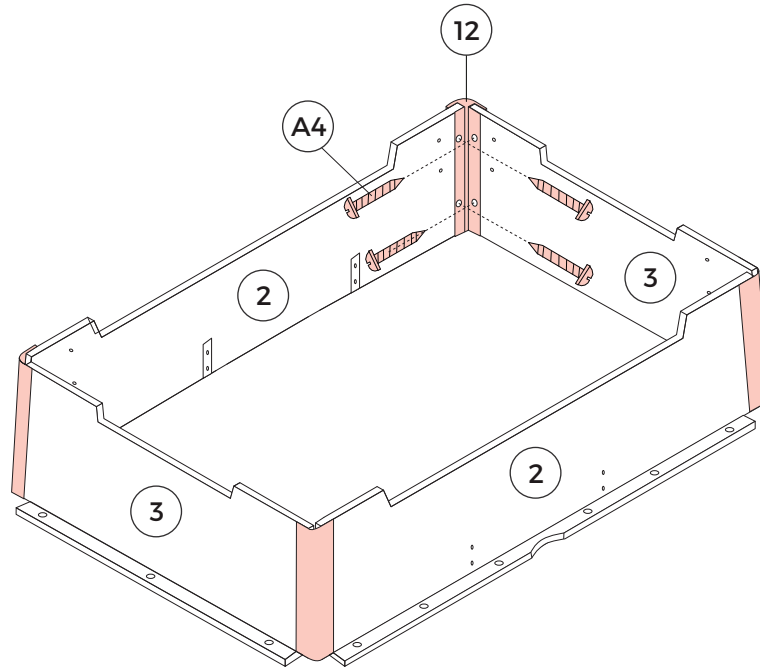
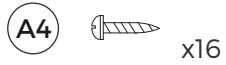
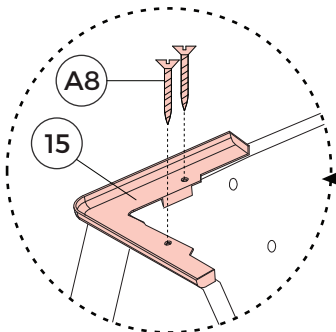
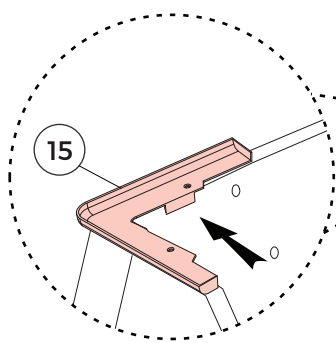

FIG. 10



Note: Make sure "FLAPS" on Top Leg Panels are FLUSH AGAINST APRONS before inserting Screws.

Nota: Asegúrese los protectores "FLAPS" sobre los Paneles de la Pata superior estén A RAS CONTRA LOS FALDONES antes de insertar los tornillos.

Note: Assurez-vous que les "RABATS" sur les panneaux de pied supérieur sont bien ALIGNÉS CONTRE LES TABLIERS avant d'insérer les Vis.

ASSEMBLY

MONTAJE

ASSEMBLAGE

FIG. 11

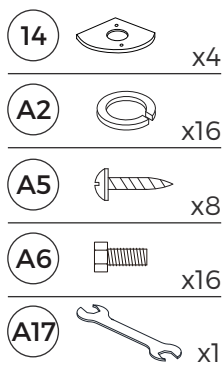
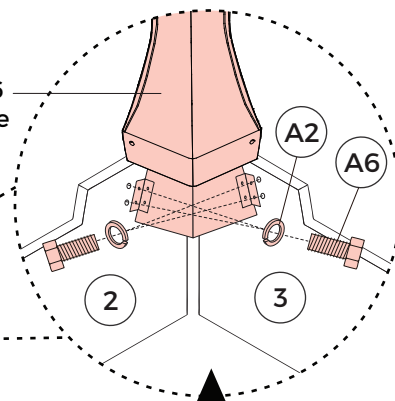
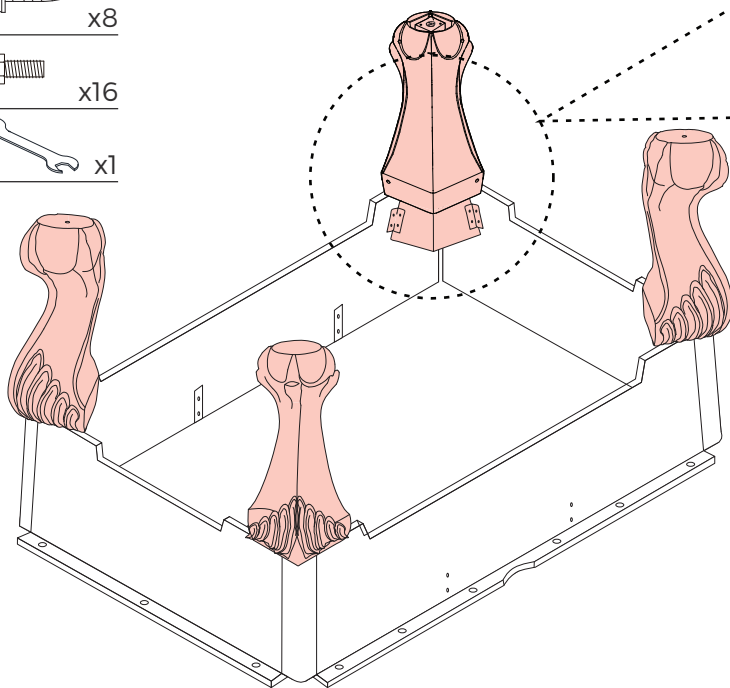

FIG. 6 Assembly
/ Ensamblaje FIG. 6
/ FIG. 6 Assemblage



Note: After this step, tighten the Bolts (A1) (See FIG. 2).

Nota: Después de este paso, apretes los Cerrojos (A1) (Vea la Fig. 2).

Note: Après cette étape, serrez les Boulons (A1) (Voir FIG. 2).

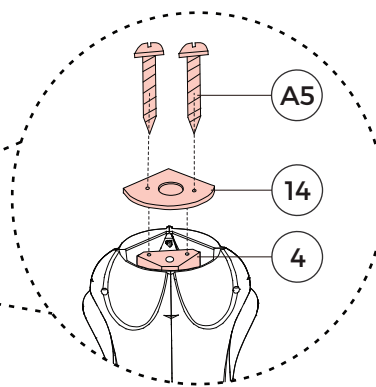
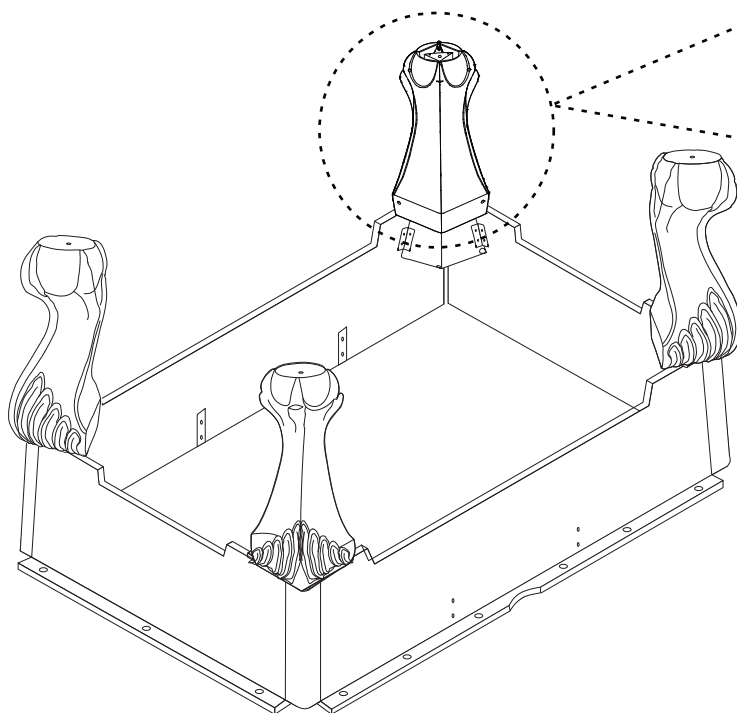

ASSEMBLY

MONTAJE

ASSEMBLAGE

FIG. 12

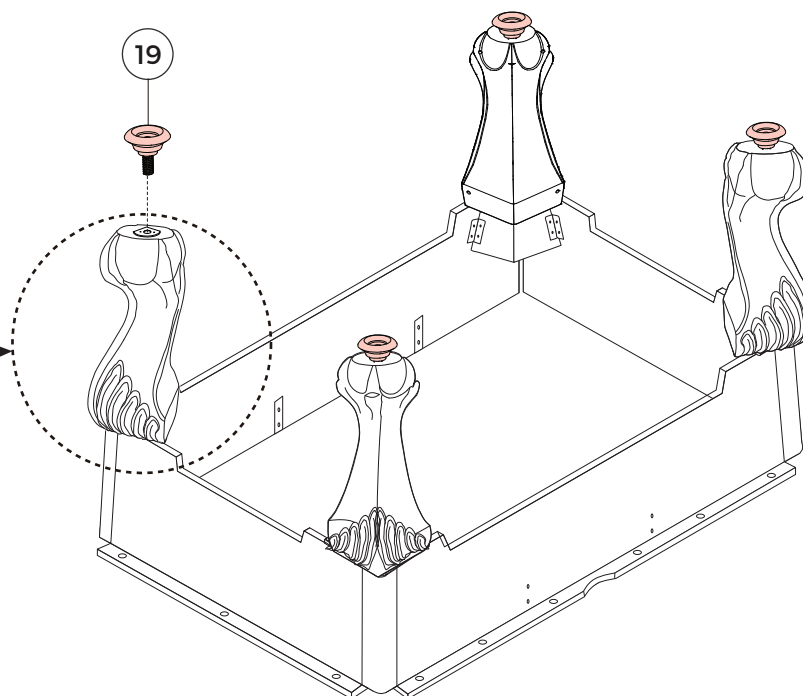

Note: Go back and make sure that all connections are tight.

Nota: Vuelva y asegúrese que todas las conexiones están apretadas.

Note: Révérifiez que toutes les connexions sont bien serrées.

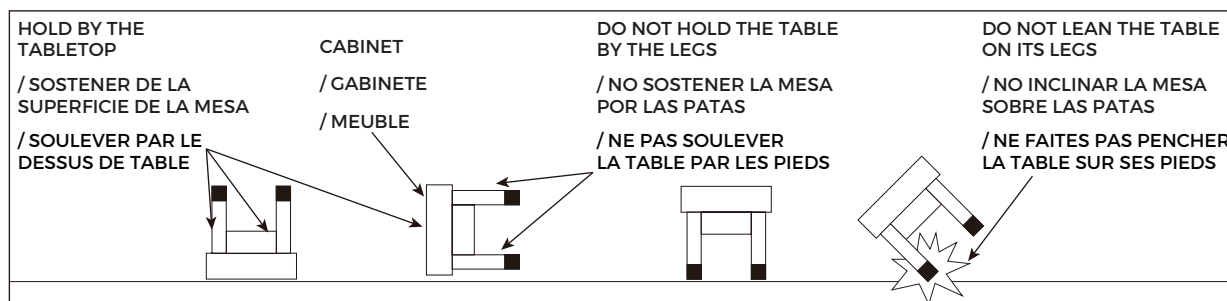
**⚠ CAUTION**

Four strong adults are recommended to turn over the table as shown.

1. Lift the table off the ground.
2. Turn the table over.
3. Place it all feet at the same time on the ground.

⚠ PRECAUCIÓN

Se recomienda la participación de cuatro adultos para invertir la mesa como se muestra.

1. Levantar la mesa del suelo.
2. Voltee la mesa.
3. Coloque las patas de la mesa sobre el piso al mismo tiempo.

⚠ ATTENTION

Il est recommandé que quatre adultes forts retournent la table comme indiqué.

1. Soulevez la table du sol.
2. Retournez-la.
3. Placez ses pieds sur le sol simultanément.

ASSEMBLY

MONTAJE

ASSEMBLAGE

FIG. 13

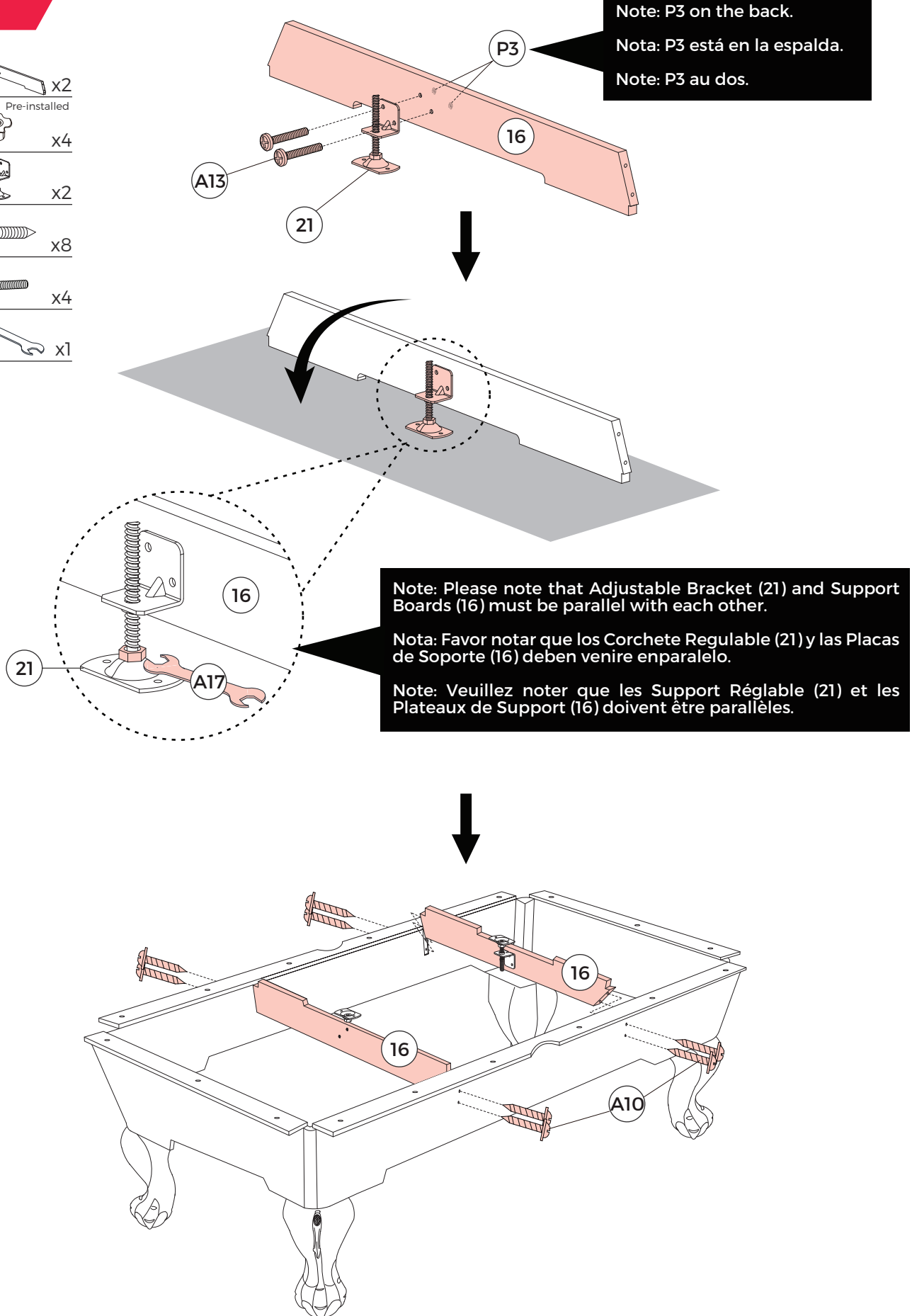
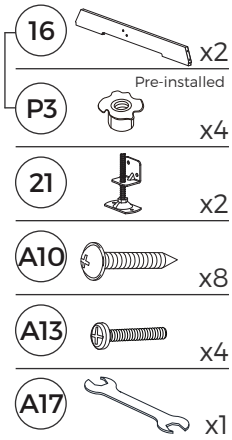

ASSEMBLY

MONTAJE

ASSEMBLAGE

FIG. 14

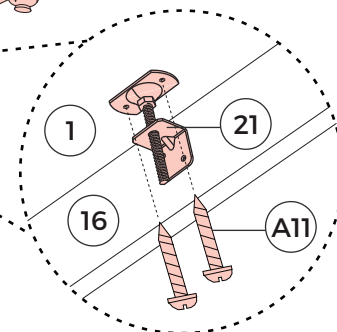
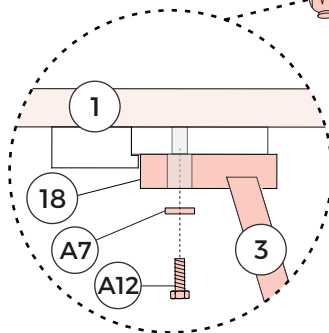
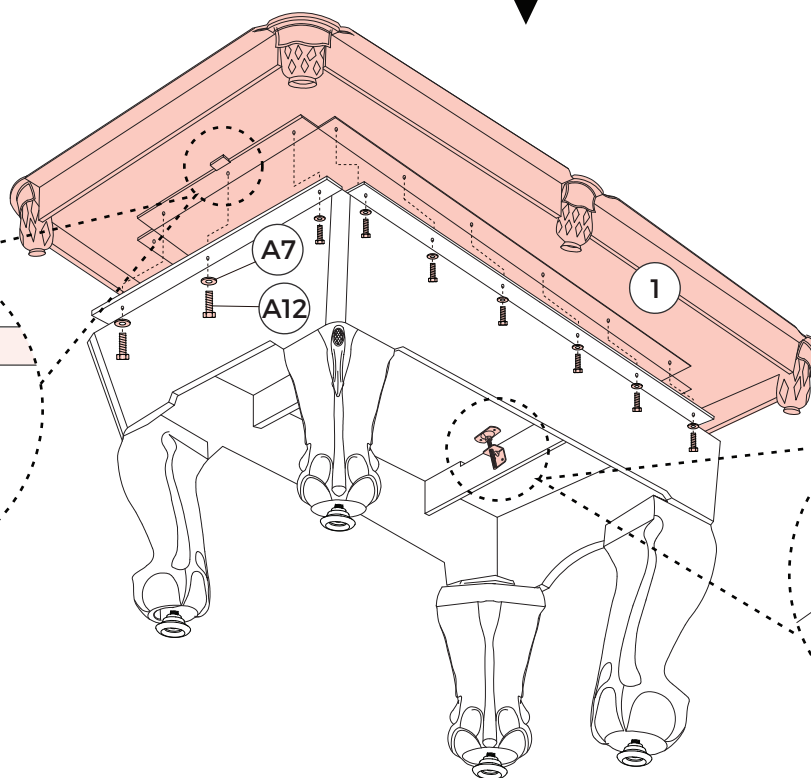
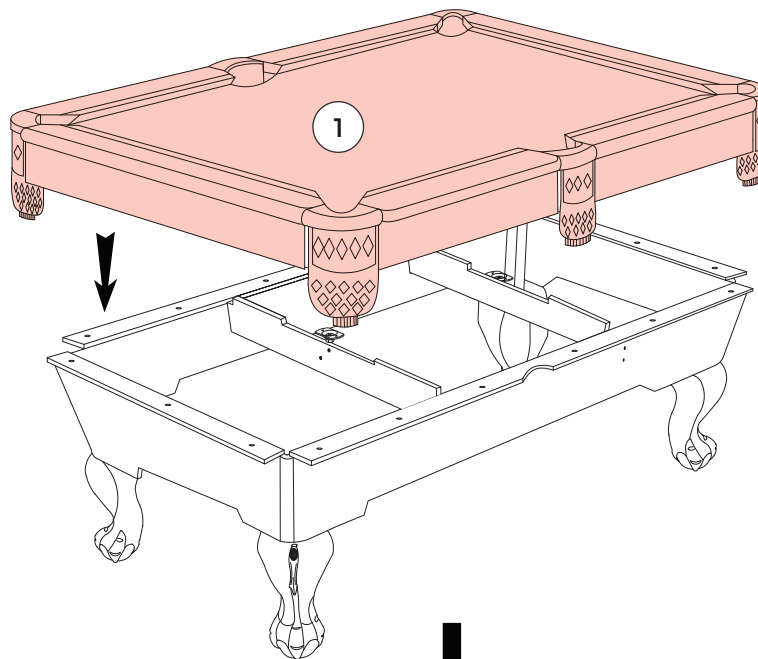
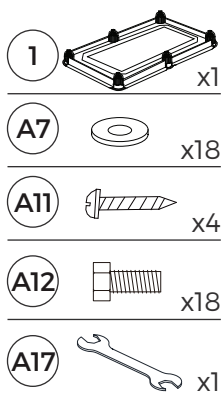

NOTE: DO NOT lift the table by the pockets. If you move the table, do not lift it by placing your hands beneath the pockets and do not lean or put pressure on them. Do not lean or sit on the end or side rails as this may damage the table.

NOTA: No levante la mesa por las troneras. Si mueva la mesa, no la levante por colocación de sus manos bajo las troneras y tampoco apoyarse o haga presión sobre ellos. No inclinarse o sentarse sobre el final o el lado de rieles, esto puede dañar la mesa.

NOTE: NE soulevez PAS la table par les poches. Si vous déplacez la table, ne la soulevez pas en plaçant vos mains sous les poches et ne vous penchez pas ni ne vous appuyez sur celles-ci. Ne vous penchez pas ni ne vous asseyez sur l'extrémité ou les rails latéraux pour éviter d'endommager la table.

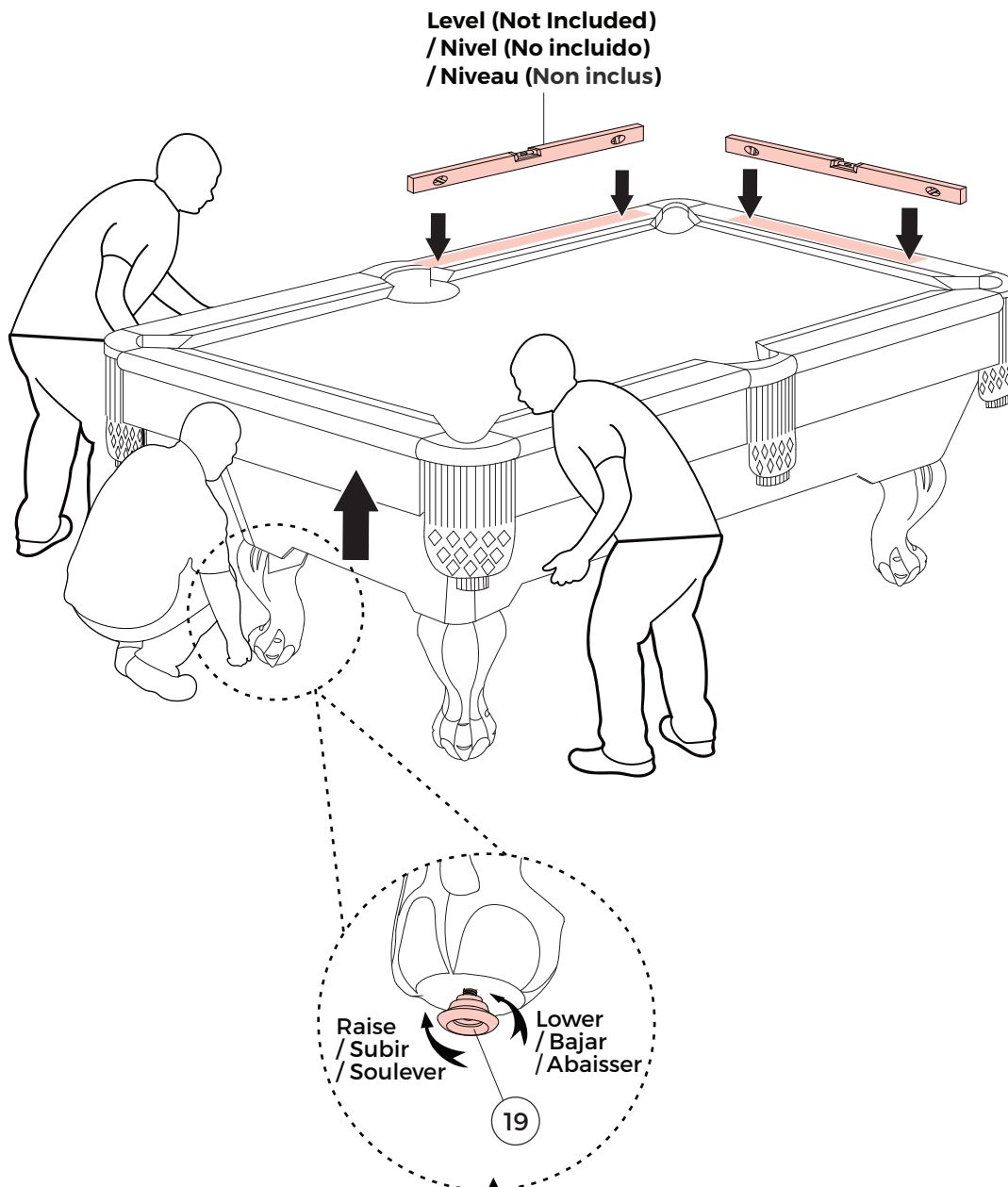
STEP 1

Note: Turn clockwise to raise and counterclockwise to lower.

Nota: Dar vuelta en el sentido del reloj para subir y en el sentido contrario del reloj para bajar.

Note: Remarque: tournez dans le sens des aiguilles d'une montre pour le lever et dans le sens contraire des aiguilles d'une montre pour l'abaisser.

STEP 2

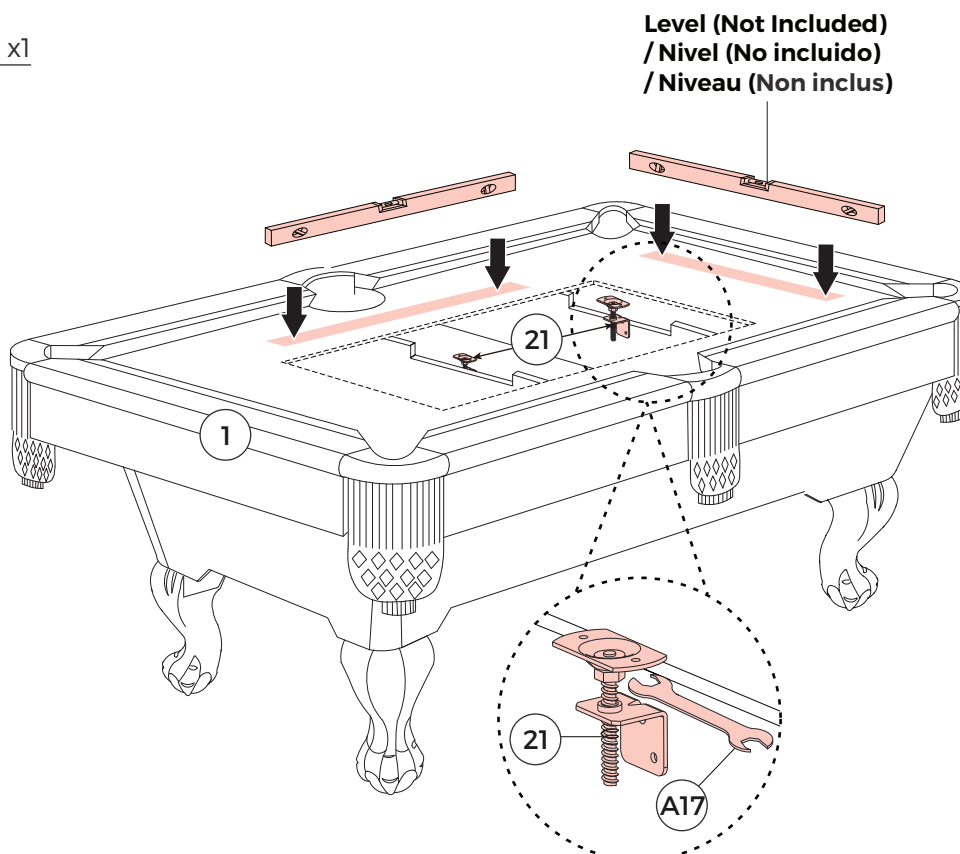

Note: Under the Mainframe (1), adjust the Adjustable Bracket (21) in order to level the playfield of the Mainframe.

Nota: Debajo del Unidad Principal (1), ajuste los Corchete Regulable (21) por el orden de nivel del campo de juego del Unidad Principal.

Note: Sous l'Unité centrale (1), réglez les Support Réglable (21) afin d'aplanir la surface de jeu de l'Unité centrale.

ADJUST CONCAVE TABLE / AJUSTAR LA MESA CÓNCAVA / POUR AJUSTER LA TABLE CONCAVE

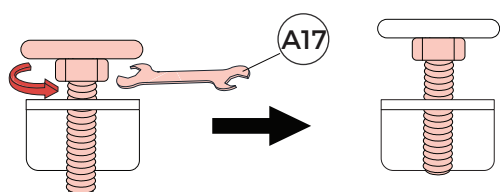

ADJUST CONVEX TABLE / AJUSTAR LA MESA CONVEXA / POUR AJUSTER LA TABLE CONVEXE

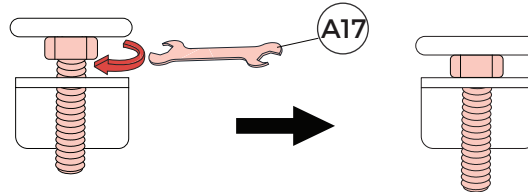
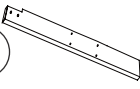



FIG. 15

- 22  x2
- 23  x2
- A14  x8

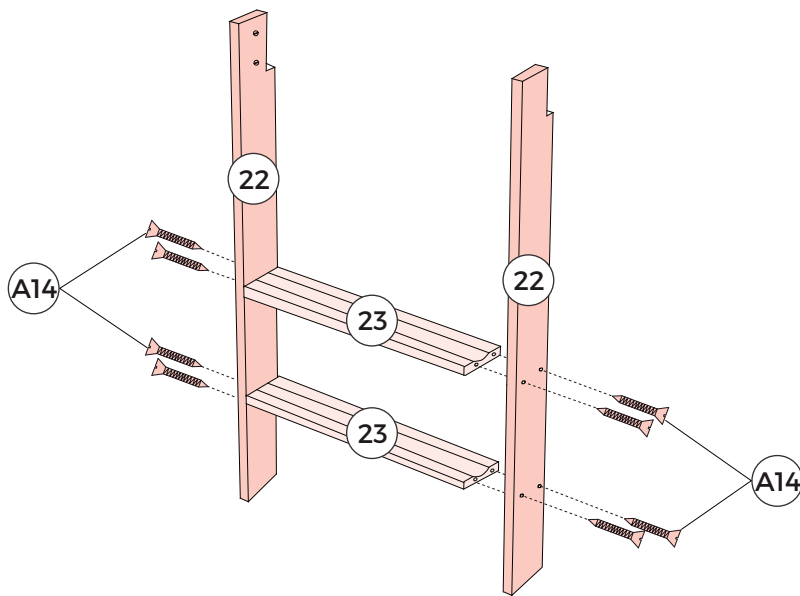
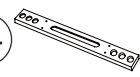



FIG. 16

- 24  x1
- 25  x1
- A14  x8

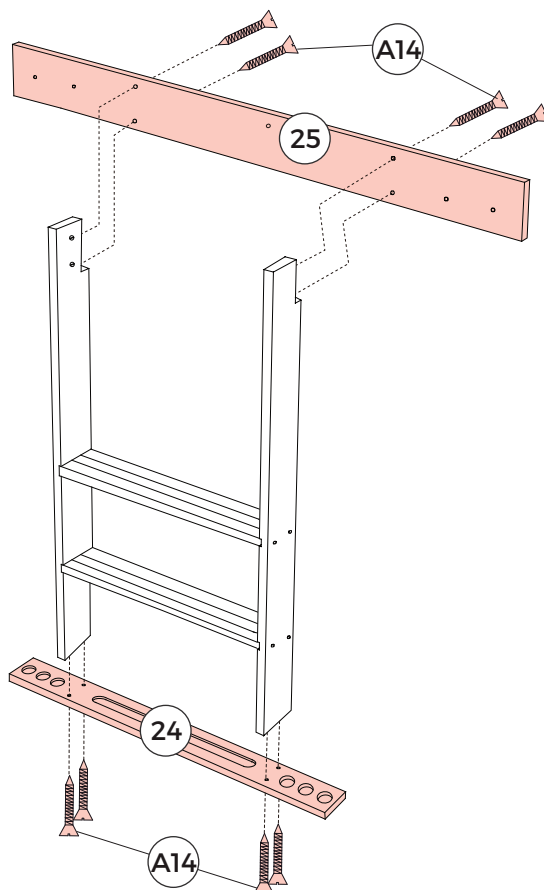
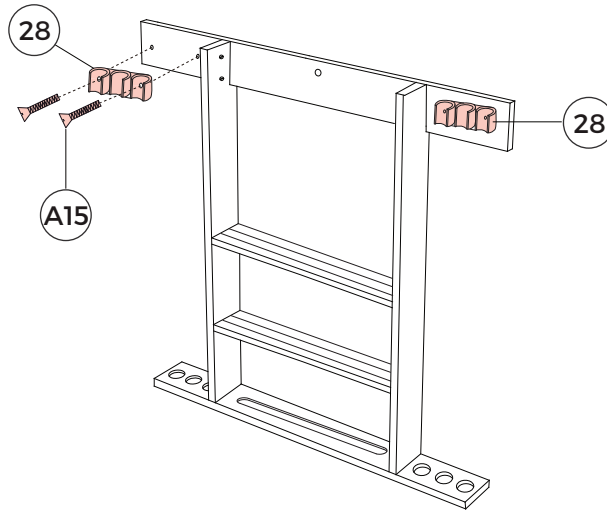
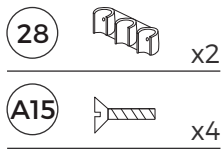

FIG. 17

FIG. 18
