

ASSEMBLY GUIDE

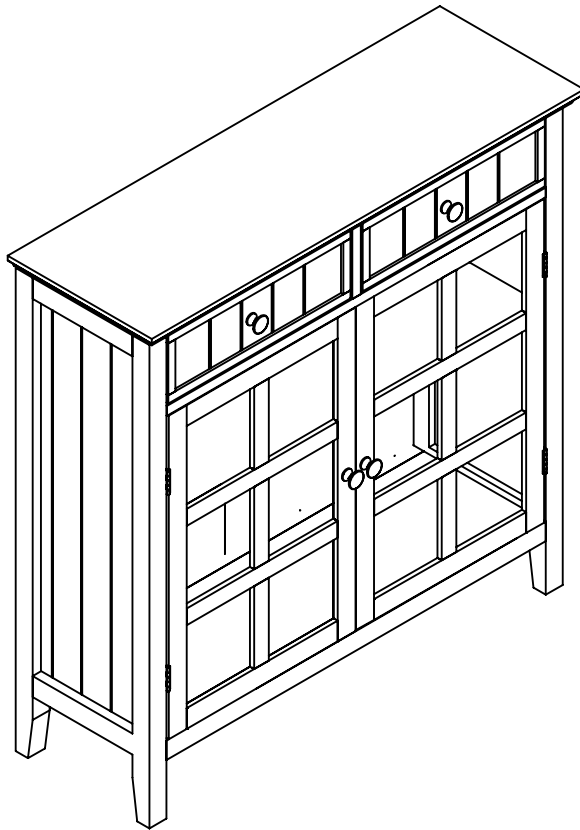

Note: This instruction booklet contains important safety information, please read and keep for future reference.

PARTS IDENTIFICATION

--Ensure that all parts and components are located before beginning assembly. Parts are labeled to help distinguish similar parts from each other. Use this PARTS IDENTIFICATION to help identify similar parts.

--Assemble on a soft surface to prevent damage to the product finish.

--Two people are needed for assembly.

--Estimated assembly time is approximately 1.5 hours.

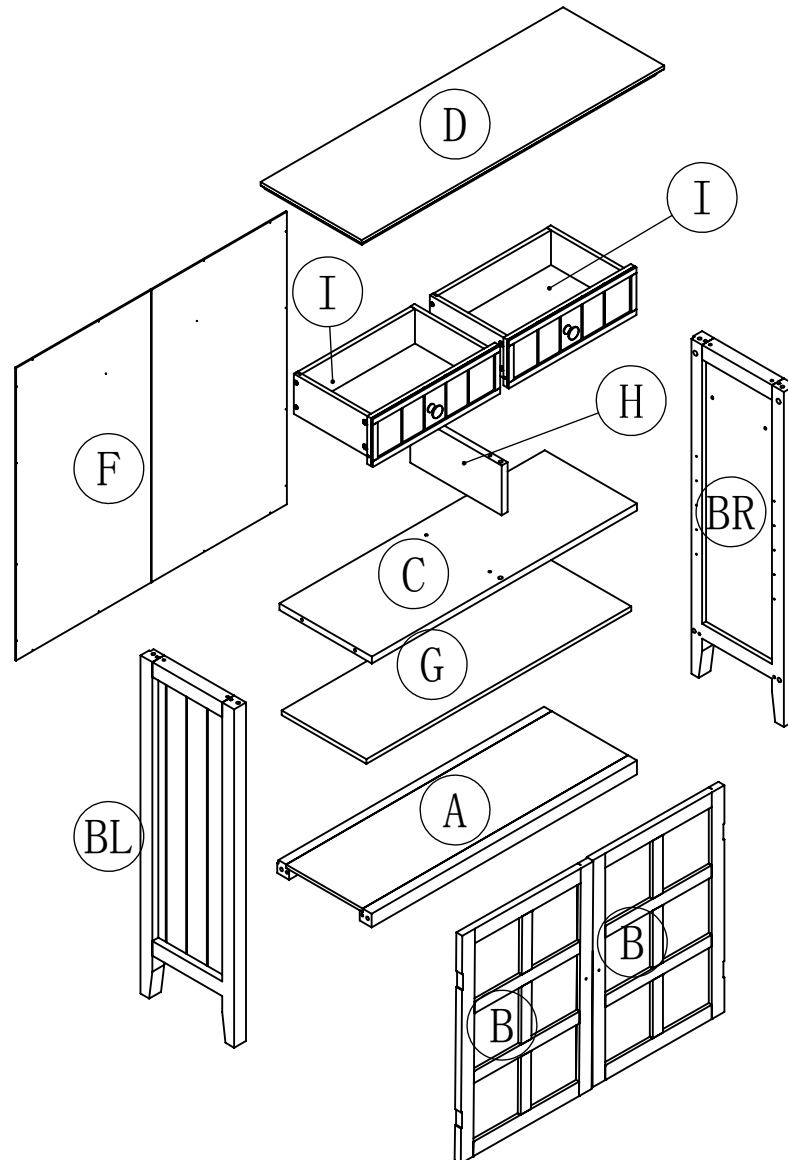

(A)BASE UNIT-1PC

(B)DOOR-2PCS

(BL)LEFT PANEL-1PC

(BR)RIGHT PANEL-1PC

(C)SHELF-1PC

(D)COVER BOARD-1PC

(F)BACK PANEL-1PC

(G)SHELF-1PC

(H)SHELF-1PC

(I)DRAWER-2PCS (I1-DRAWER FRONT PANEL-2PCS, I2-DRAWER RIGHT PANEL-2PCS, I3-DRAWER LEFT PANEL-2PCS, I4-DRAWER BACK PANEL-2PCS, I5-DRAWER BOTTOM PANEL-2PCS)

HARDWARE IDENTIFICATION

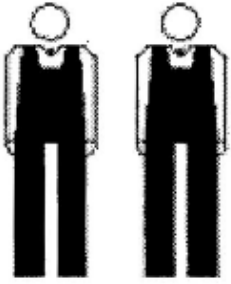

TOOL REQUIRED

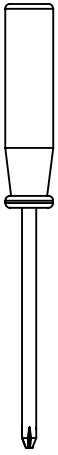

PHILLIPS HEAD
SCREWDRIVER

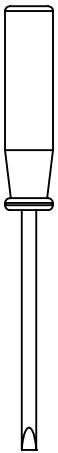

SHORT FLAT
SCREWDRIVER

(R1)CAM BOLT-8PCS

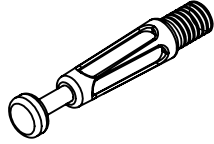

(R15)CAM BOLT-9PCS

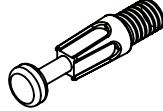

(R2)CAM LOCK-17PCS

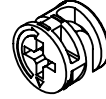

(R3)FLAT HEAD SCREW-4PCS

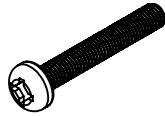

(R4)HINGE-4PCS

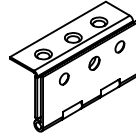

(R5)DOOR KNOB-4PCS



(R6)MAGNET-2PCS

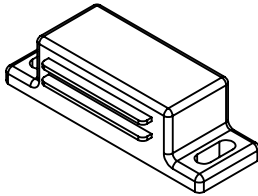

(R7)IRON-2PCS

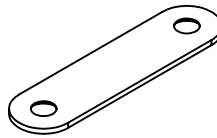

(R8)SHELF SUPPORT-4PCS

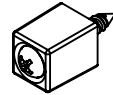

(R9)FLAT HEAD SCREW
ST3X12-59PCS



(R10)SUPPORT STRAP-1PC

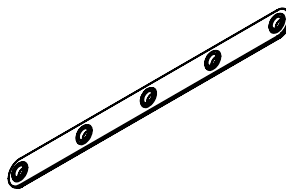

(R11)WOOD DOWEL-16PCS

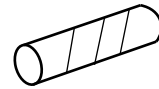

(R12)FLAT HEAD SCREW
ST3.5X30-9PCS



(R13)DRAWER STOPPER-2PCS

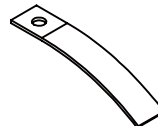

(R14)PLASTIC SCREW
ANCHOR-1PC

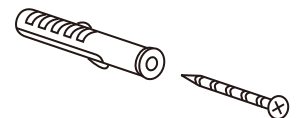

CAM LOCK SYSTEM

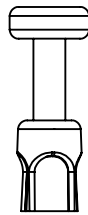
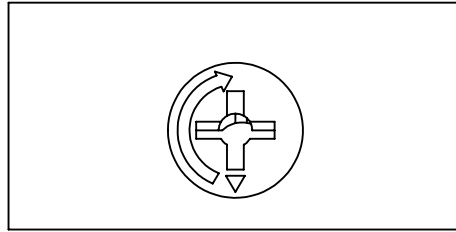

(1)

CORRECT

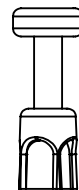
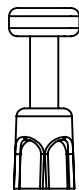
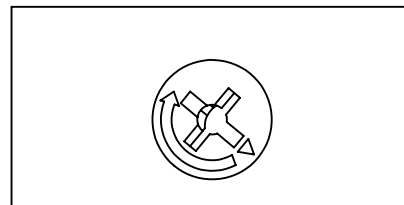
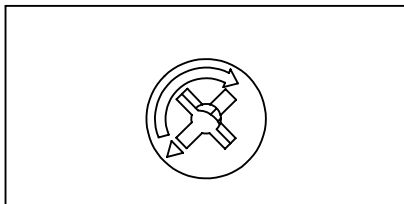

(2)

WRONG

Ensure starting position is correct, adjust cam bolt by pushing or pulling during assembly. Turn clockwise until secure.

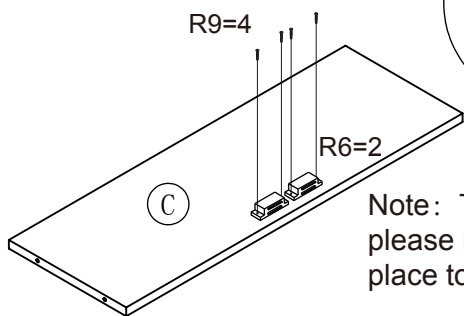
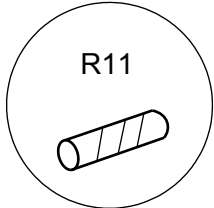
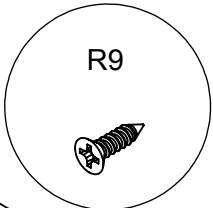
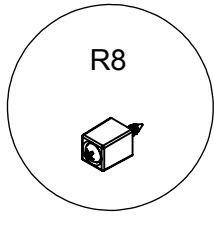
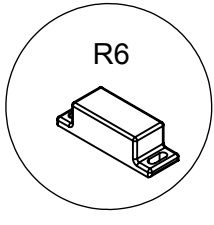
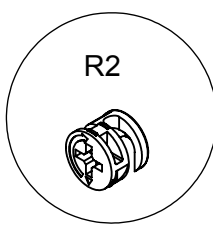
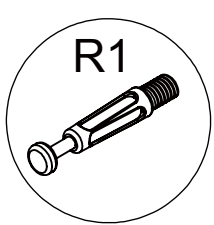

Note: The magnets are adjustable, please make sure they are in the right place to attach the door closely.

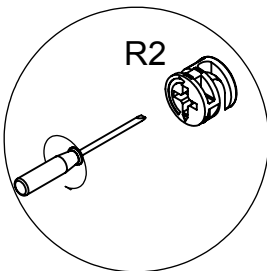
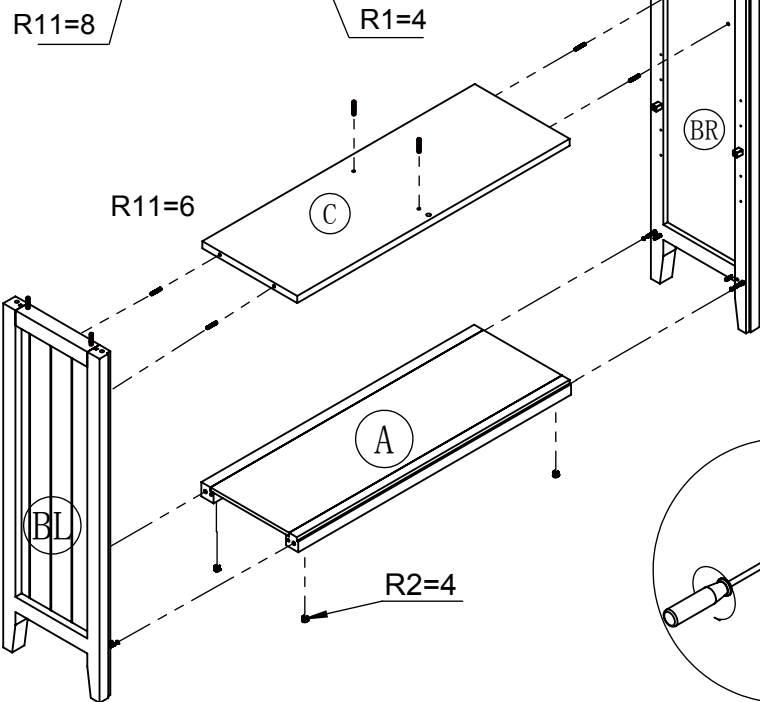
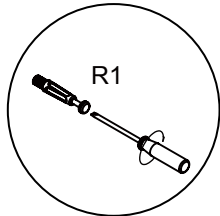
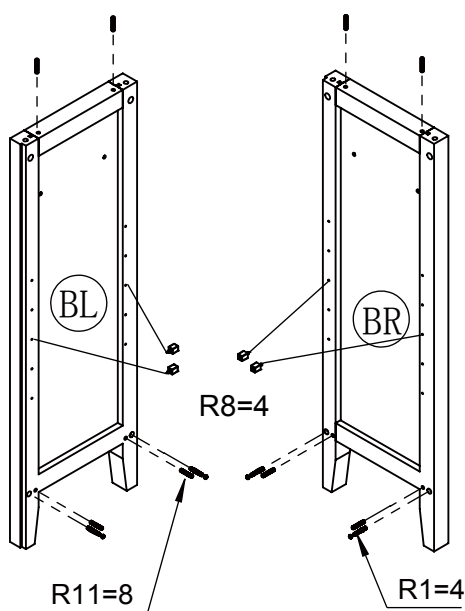

(R1)CAM BOLT-4PCS



(R2)CAM LOCK-4PCS



(R6)MAGNET-2PCS

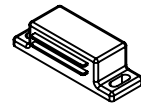

(R8)SHELF SUPPORT-4PCS



(R9)FLAT HEAD SCREW
ST3X12-4PCS



(R11)WOOD DOWEL-14PCS

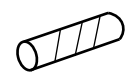

1.a)Fasten 2 magnet R6 to shelf C,using 4 flat head screw R9(ST3X12).

b)Fasten 4 cam bolt R1 and insert 8 wood dowel R11 to left panel BL and right panel BR.

c)Fasten 4 shelf support R8 to left panel BL,right panel BR.

d)Insert 6 wood dowel R11 to shelf C.

e)Fasten left panel BL, right panel BR to base unit A and shelf C, using 4 cam lock R2.

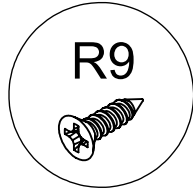

(R9)FLAT HEAD SCREW
ST3X12-24PCS

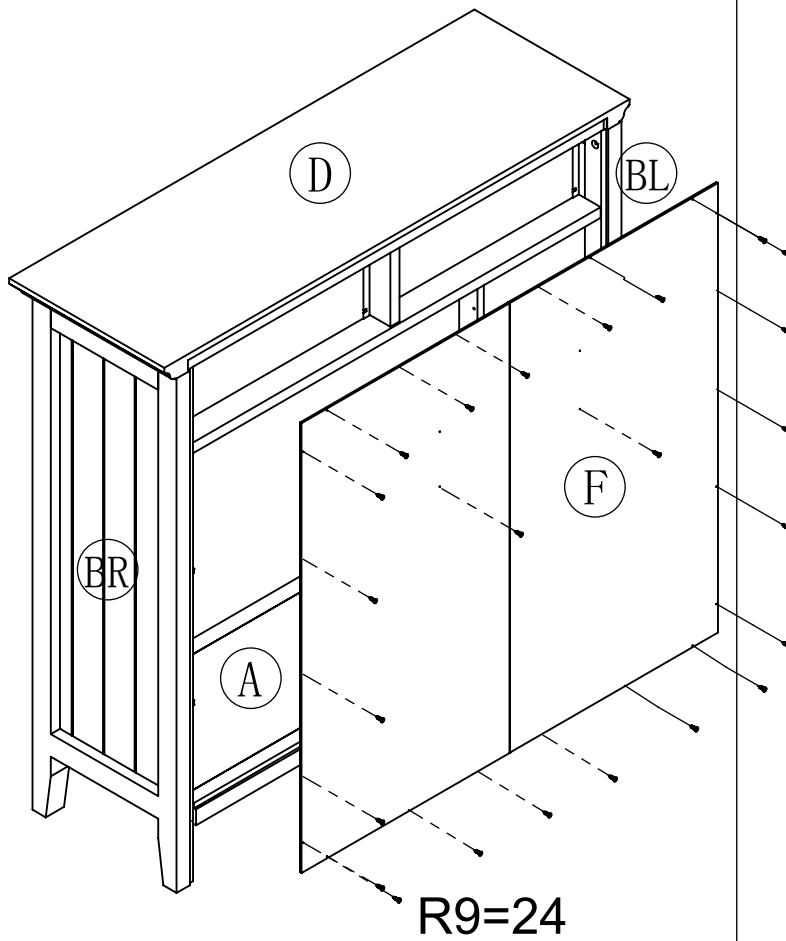

3.a)Fasten back panel
F to left panel BL ,
right panel BR,base
unit A and cover
board D,using 22 flat
head screw R9(ST3X12)

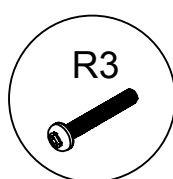
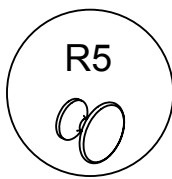
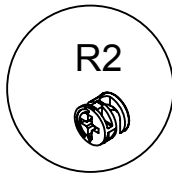
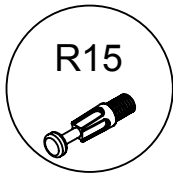
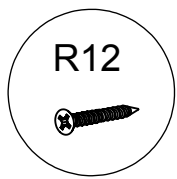

(R12)FLAT HEAD SCREW
ST3.5X30-8PCS



(R15)CAM BOLT -8PCS

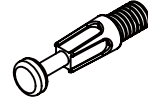

(R2)CAM LOCK-8PCS



(R5)DOOR KNOB-2PC



(R3)FLAT HEAD SCREW-2PC

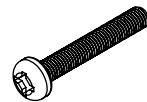

4.a)Fasten 4 cam bolt R15 to drawer front panel I1.

b)Fasten drawer left panel I3 and right panel I2 to drawer back panel I4,using 4 flat head screw R12.

c)Slide drawer bottom panel I5 into place.

d)Fasten drawer front panel I1 to drawer left panel I3 and right panel I2,using 4 cam lock R2.

e)Fasten door knob R5 to drawer front panel I1, using 1 flat head screw R3.

f)Repeat above steps for another drawer.

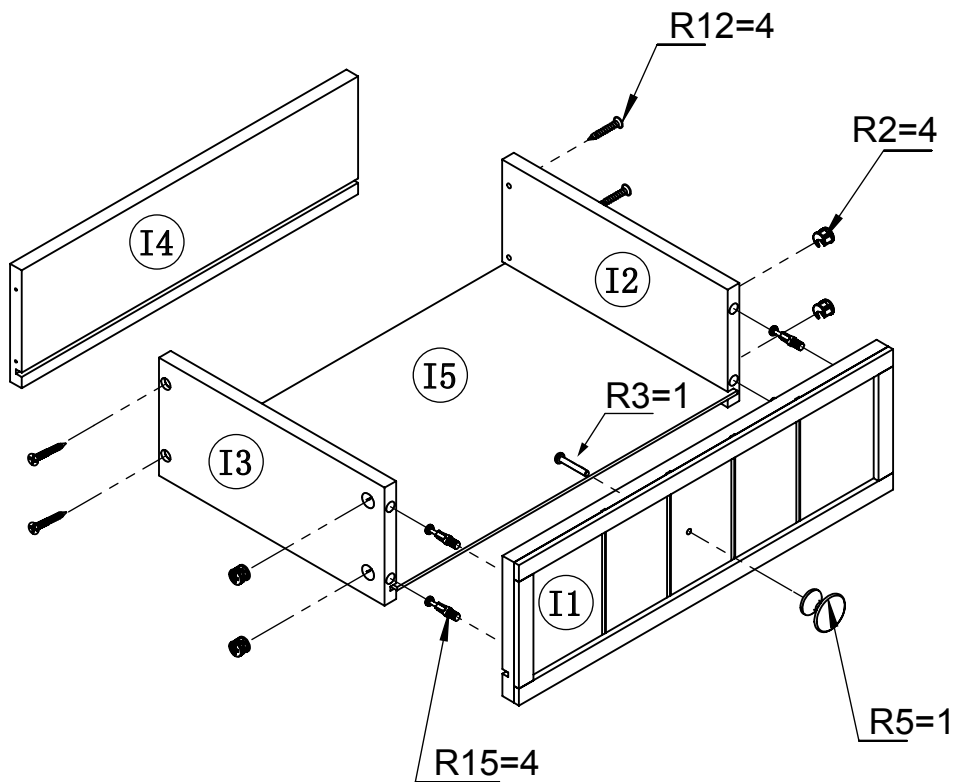

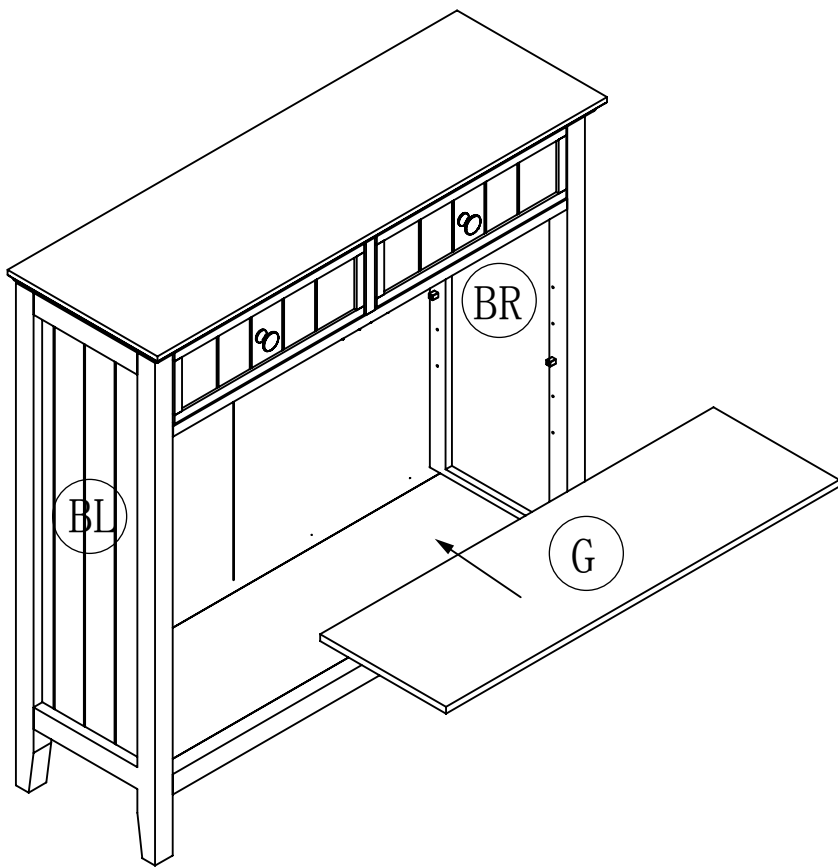

5.a)Put 2 drawer I into place.

b)Put shelf G on shelf support.

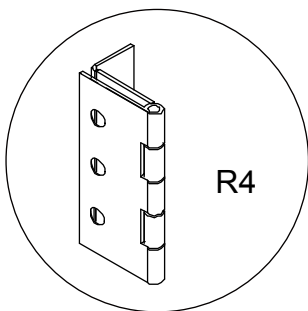
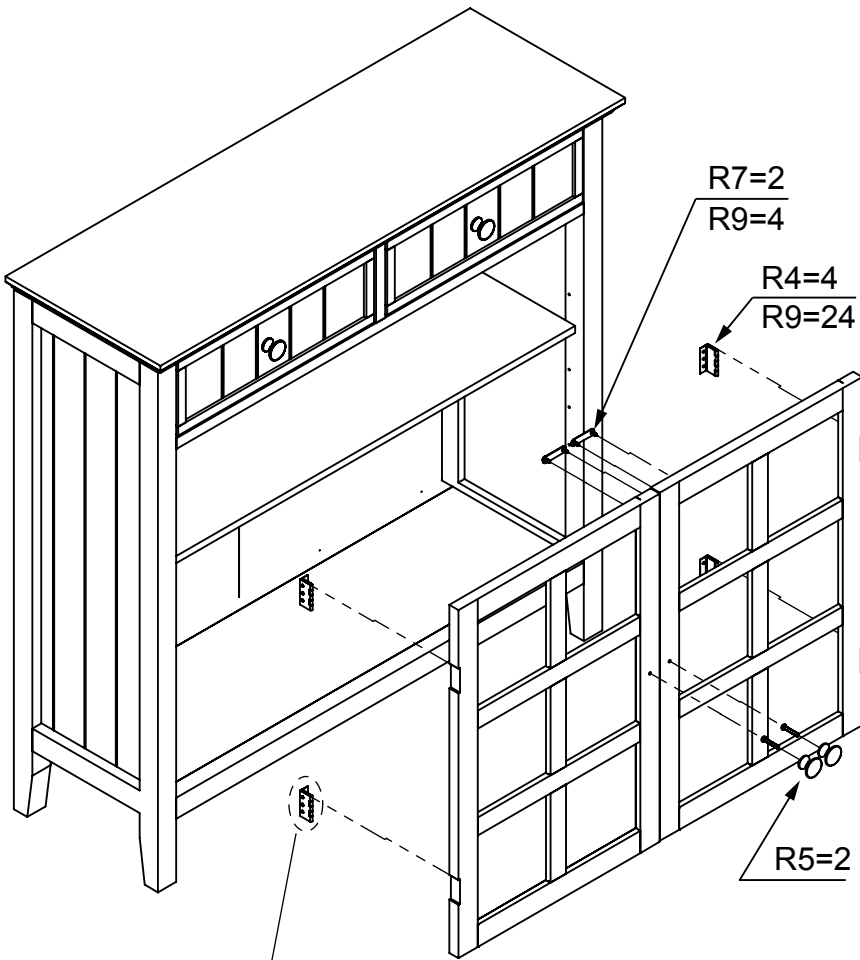
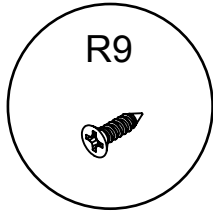
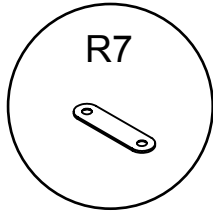
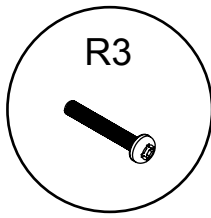
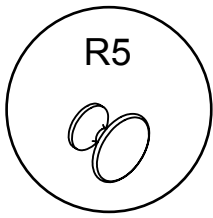
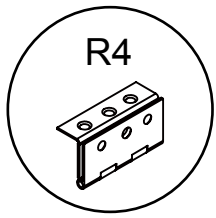

(R4)HINGE-4PCS

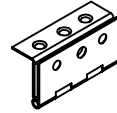

(R5)DOOR KNOB-2PCS



(R3)FLAT HEAD SCREW-2PCS



(R7)IRON-2PCS



(R9)FLAT HEAD SCREW

ST3X12-28PCS



6.a)Fasten 2 door knob R5 to 2 door B,using 2 flat head screw R3.

b)Fasten 2 iron R7 to 2 door B,using 4 flat head screw R9(ST3X12).

c)Fasten 4 hinge R4 to left panel BL and right panel BR,using 12 flat head screw R9(ST3X12).

d)Fasten hinge R4 to 2 door B,using 12 flat head screw R9(ST3X12).

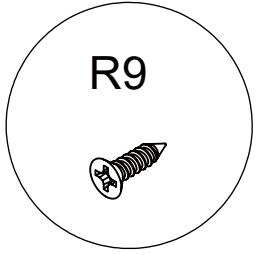

R9

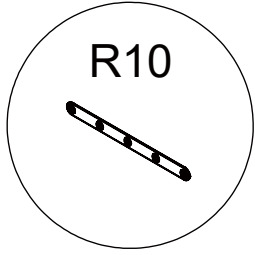

R10

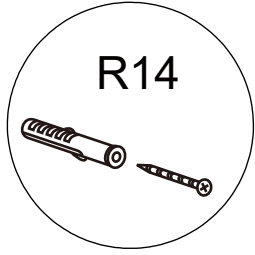

R14

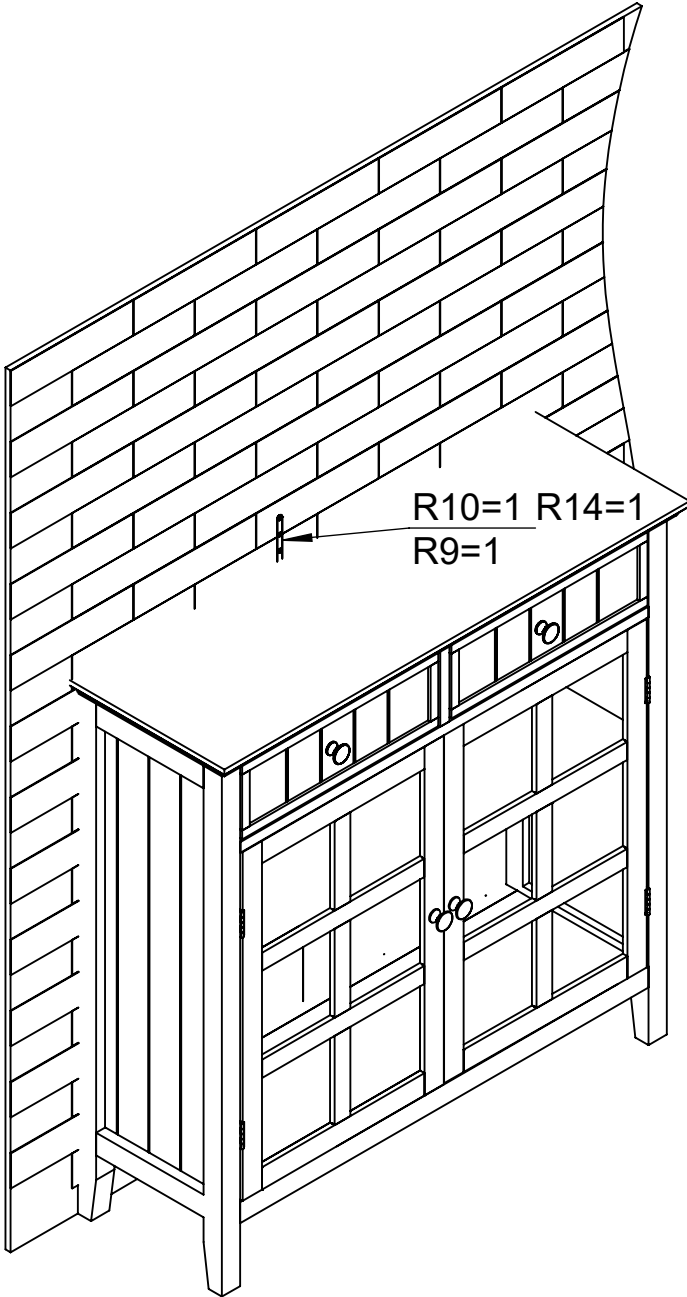

R10=1 R14=1
R9=1

(R9)FLAT HEAD SCREW
ST3X12-1PC



(R10)SUPPORT STRAP -1PC

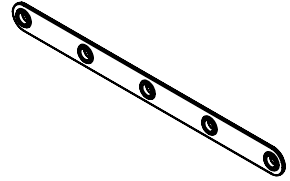

(R14)PLASTIC SCREW
ANCHOR-1PC

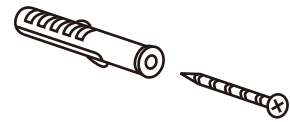

7.As an added safety feature,fasten support strap R10 to cover board D ,using flat head R9(ST3X12),it must be attached to the wall, using 1 plastic screw anchor R14.