

ASSEMBLY INSTRUCTION
WF292505

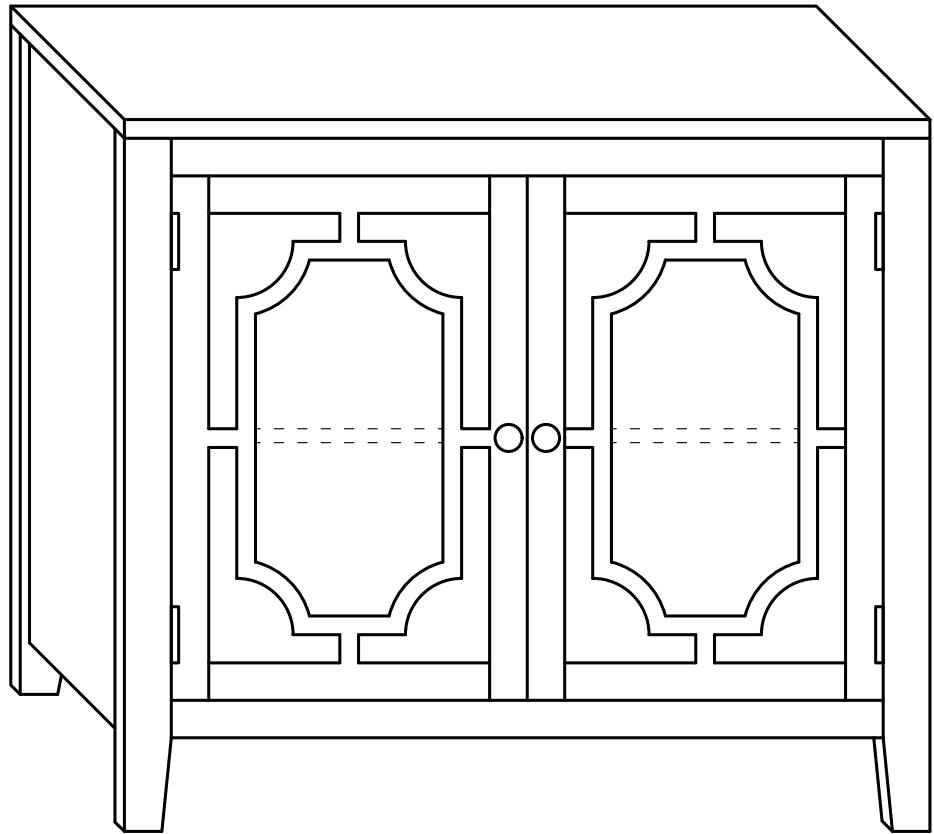

PART LIST

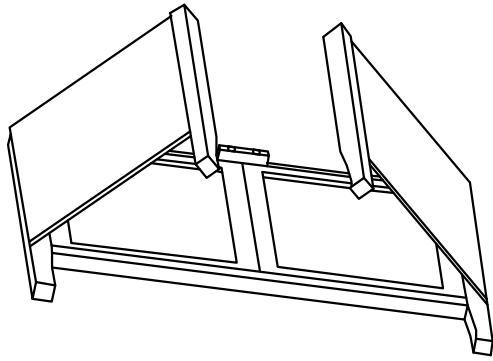

- (A)** Front+Side Component
Quantity: 1 pc



- (B)** Top Component
Quantity: 1 pc

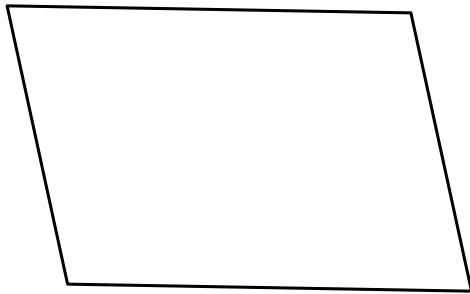

- (D)** Back panel
Quantity: 1 pc

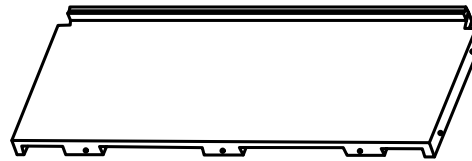

- (C)** Bottom Component
Quantity: 1 pc

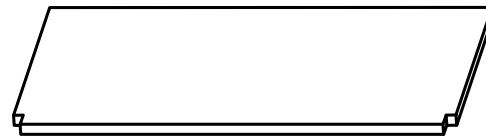

- (E)** Middle Component
Quantity: 1 pc

HARDWARE LIST



- (1)** 6x30 mm
Quantity: 15 pcs



- (2)** 6x10 mm
Quantity: 15 pcs

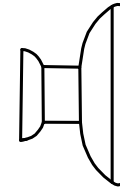

- (3)** Quantity: 2 pcs



- (4)** 4x25 mm
Quantity: 2 pcs



- (5)** Quantity: 4 pcs



- (6)** Quantity: 1 pc



- (7)** 3x10 mm
Quantity: 4 pcs

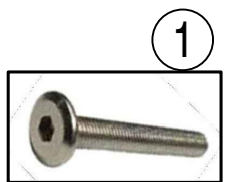

Quantity:
7 pcs

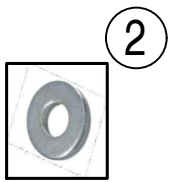

Quantity:
7 pcs

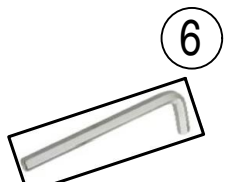

Quantity:
1 pc

STEP 1

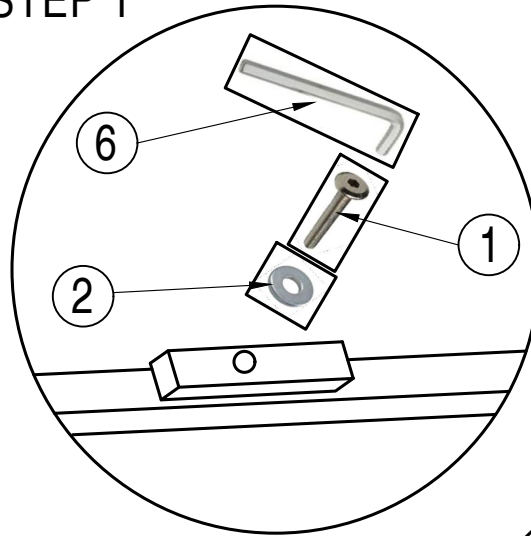

DETAIL X

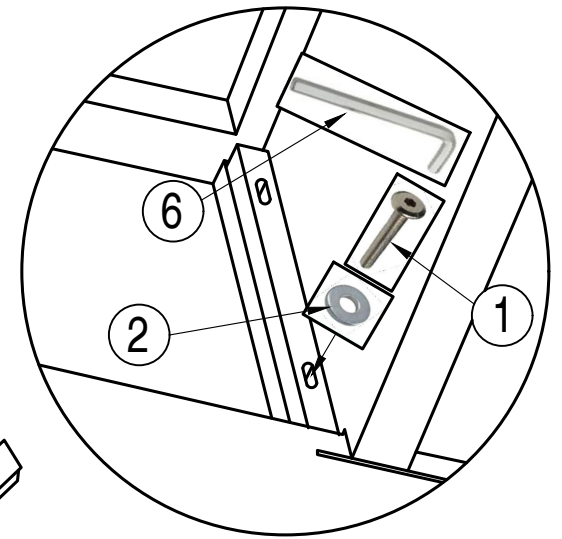

DETAIL Y

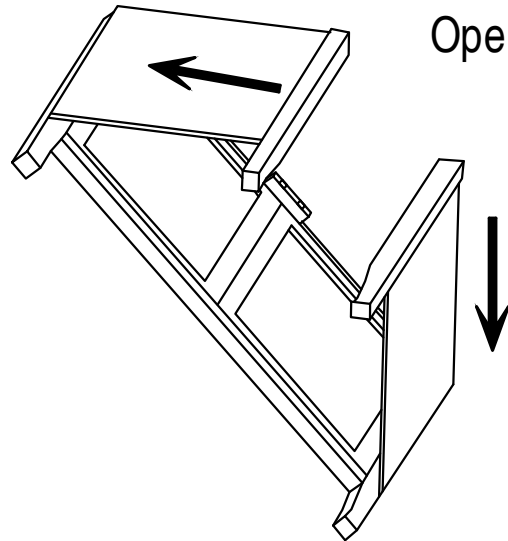

Open to side

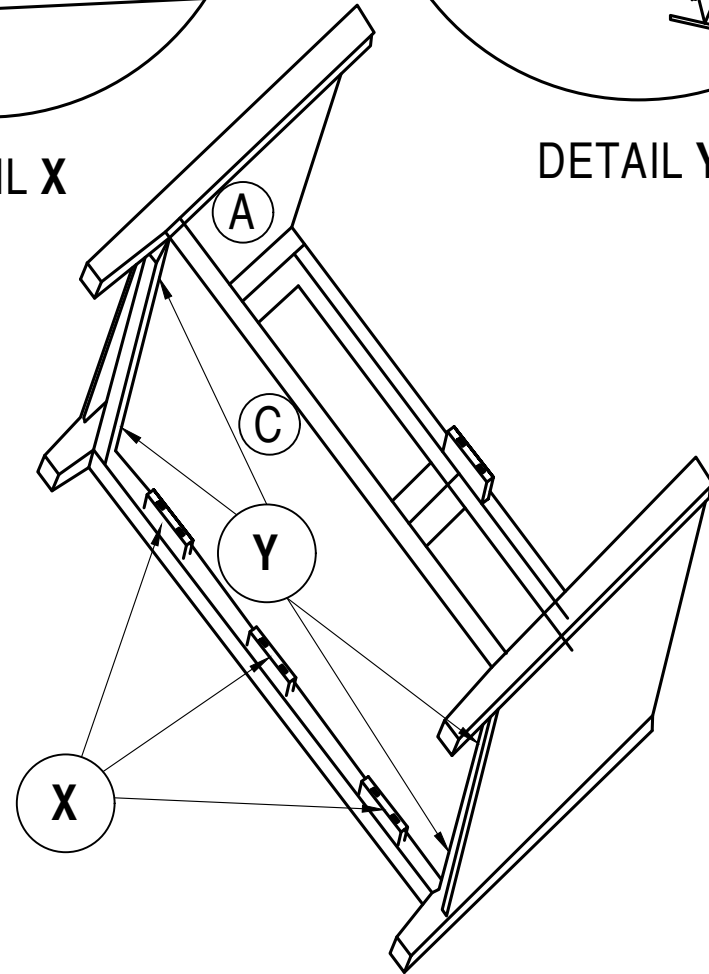

5



Quantity: 4 pcs

7



Quantity: 4 pcs

STEP 2

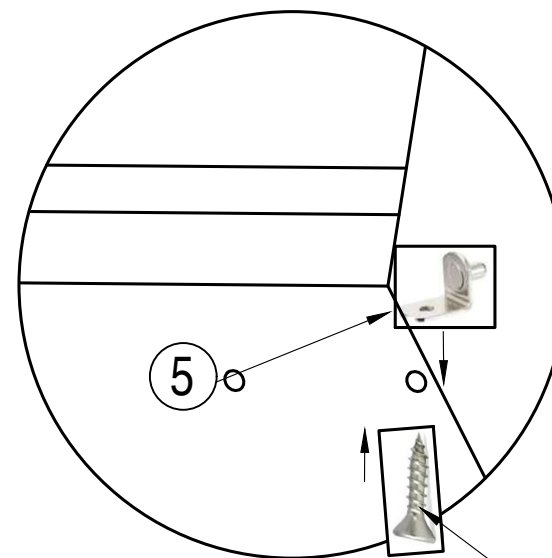
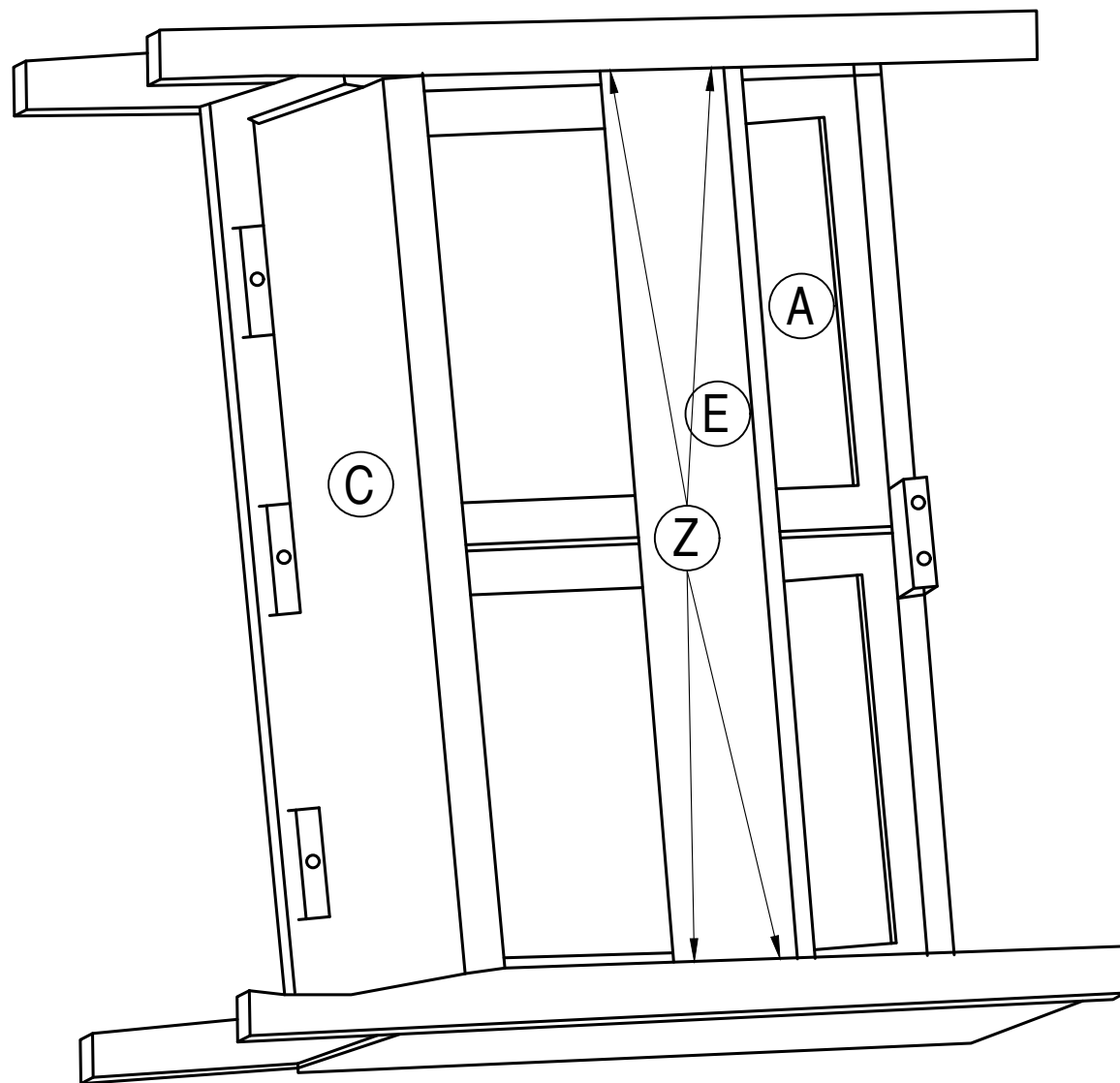



DETAIL Z

7

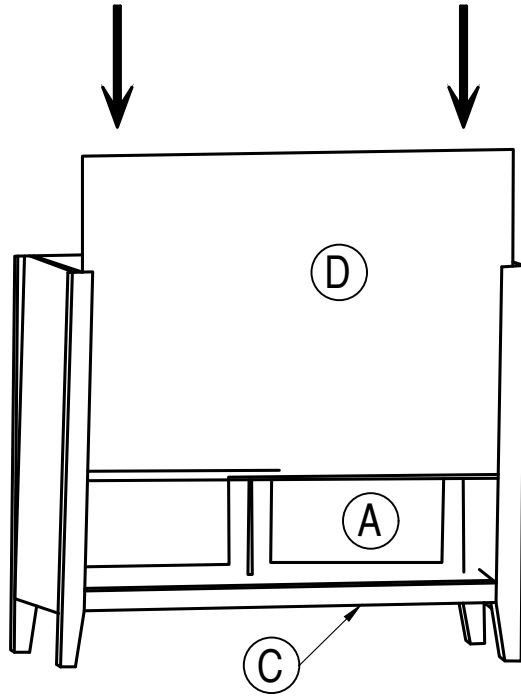
STEP 3



STEP 4

 <p>Quantity: 8 pcs</p>	 <p>Quantity: 8 pcs</p>	 <p>Quantity: 1 pc</p>
--	--	---

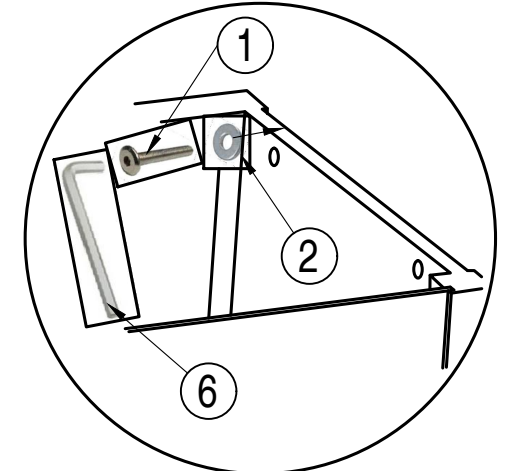
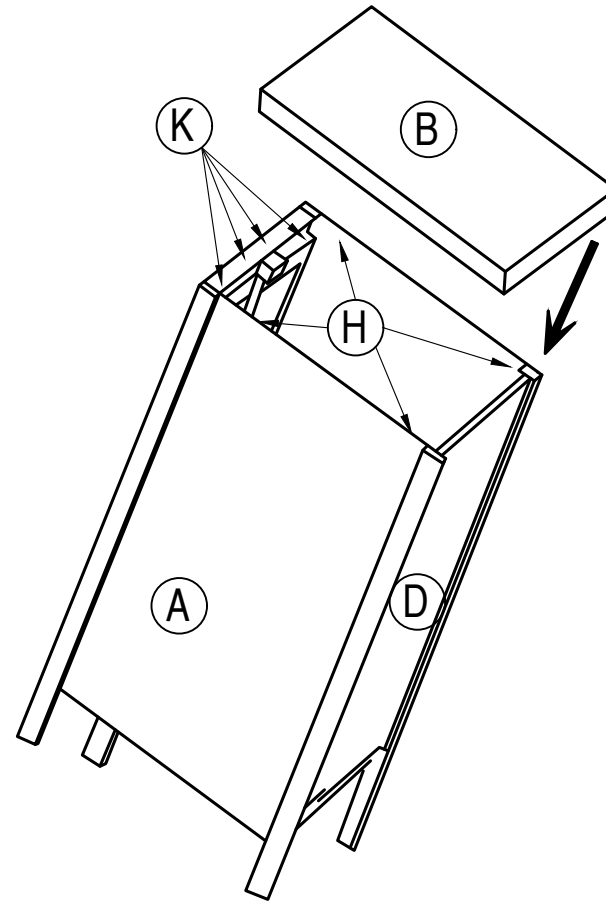

DETAIL K

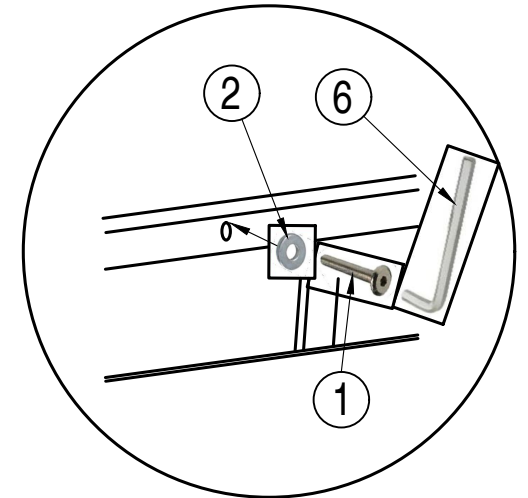

DETAIL H

3

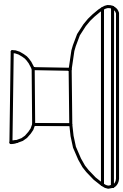

Quantity: 2 pcs

4



Quantity: 2 pcs

STEP 5

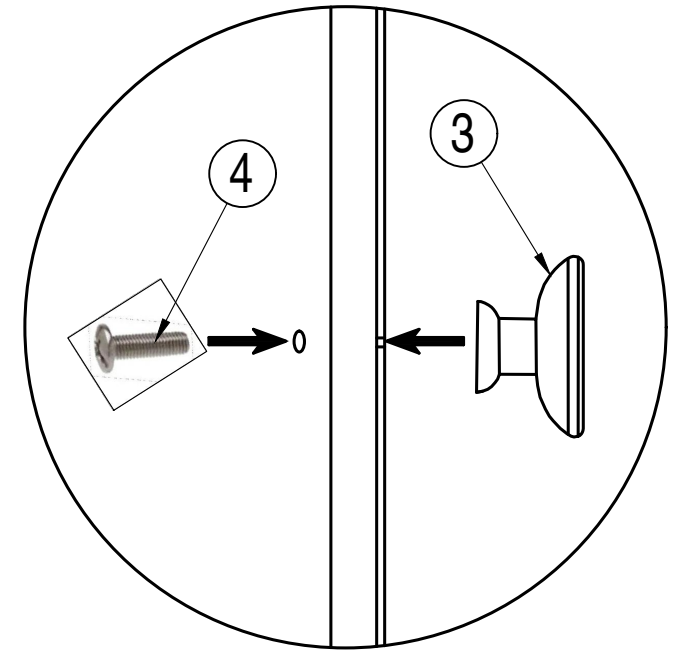

DETAIL P

