

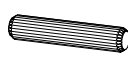

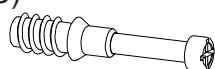

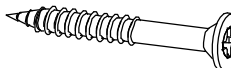

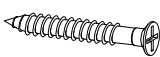

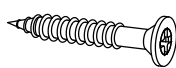

Before you start, here is some helpful advice:

1. We suggest you spend a short time reading through this leaflet and then follow the simple step-by-step instructions.
2. Owing to the size and weight of the desk, we recommend that it is assembled by two adults, on a carpeted or padded area, in the room that it is intended for. Approximate assembly time: 60 minutes.
3. Please do not use any tools other than those provided or recommended in these instructions.
4. Please do not throw away any of the packaging or instructions until you have checked all the components and hardware and the furniture is fully assembled.
5. Assemble all components loosely until advised to tighten. Depending on use, it may be necessary to tighten the components from time to time, so please save the tools that have been provided.
6. Please keep all pieces out of reach of children.

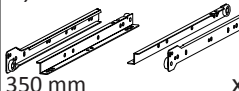

**Hardware :**

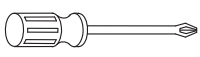
<p>A) Dowel Big/Wood</p>  <p>∅ 8 x 30 mm x 34</p>	<p>B) Dowel Small/Wood</p>  <p>∅ 6 x 30 mm x 12</p>	<p>C) Cambolt/Metal</p>  <p>∅ 6 x 35 mm x 26</p>	<p>D) Screw/Metal</p>  <p>M 12 x 45 mm x 4</p>	<p>E) Screw/Metal</p>  <p>M 8 x 39 mm x 12</p>
<p>F) Screw/Metal</p>  <p>M 12 x 35 mm x 6</p>	<p>G) Anti-tipping strap/Polyester</p>  <p>± 150 mm x 2</p>	<p>H) Screw/Metal</p>  <p>M 3.5 x 15.5 mm x 8</p>	<p>I) Screw/Metal</p>  <p>M 3.5 x 13 mm x 18</p>	<p>J) Screw/Metal</p>  <p>M 6.5 x 10.5 mm x 12</p>
<p>K) CamLock Big/Metal</p>  <p>∅ 15 mm x 14</p>	<p>L) CamLock Small/Metal</p>  <p>∅ 12 mm x 12</p>	<p>M) Wedge/Plastic</p>  <p>9 x 14 x 10 mm x 8</p>	<p>N) Rail/Metal</p>  <p>350 mm x 3</p>	<p>O) Ring/Metal</p>  <p>∅ 20 mm x 2</p>
<p>P) Screw/Metal</p>  <p>M 3.5 x 15.5 mm x 2</p>	<p>Q) x 1</p>  <p>Screwdriver (Not Include)</p>			

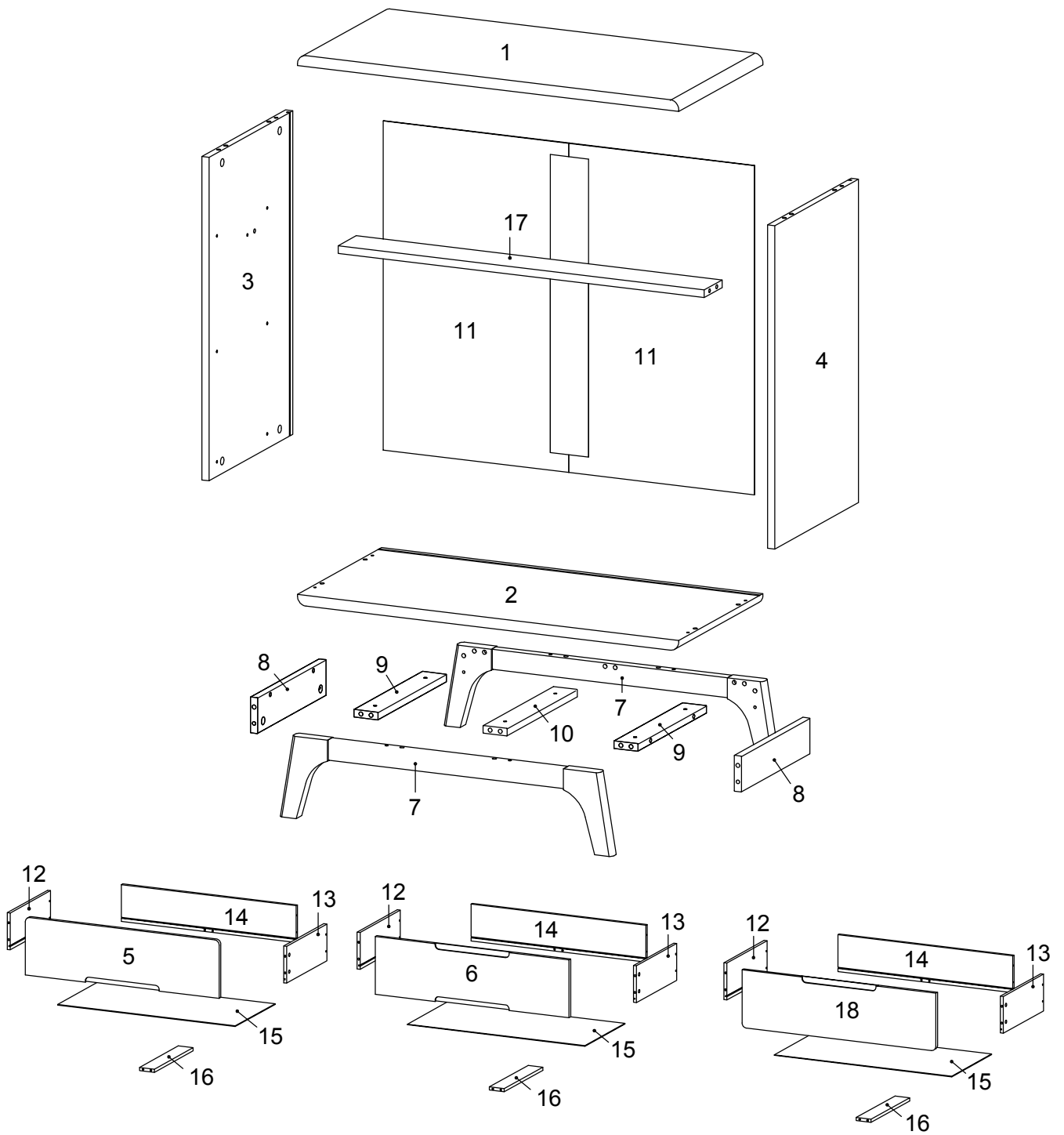

**Components:**

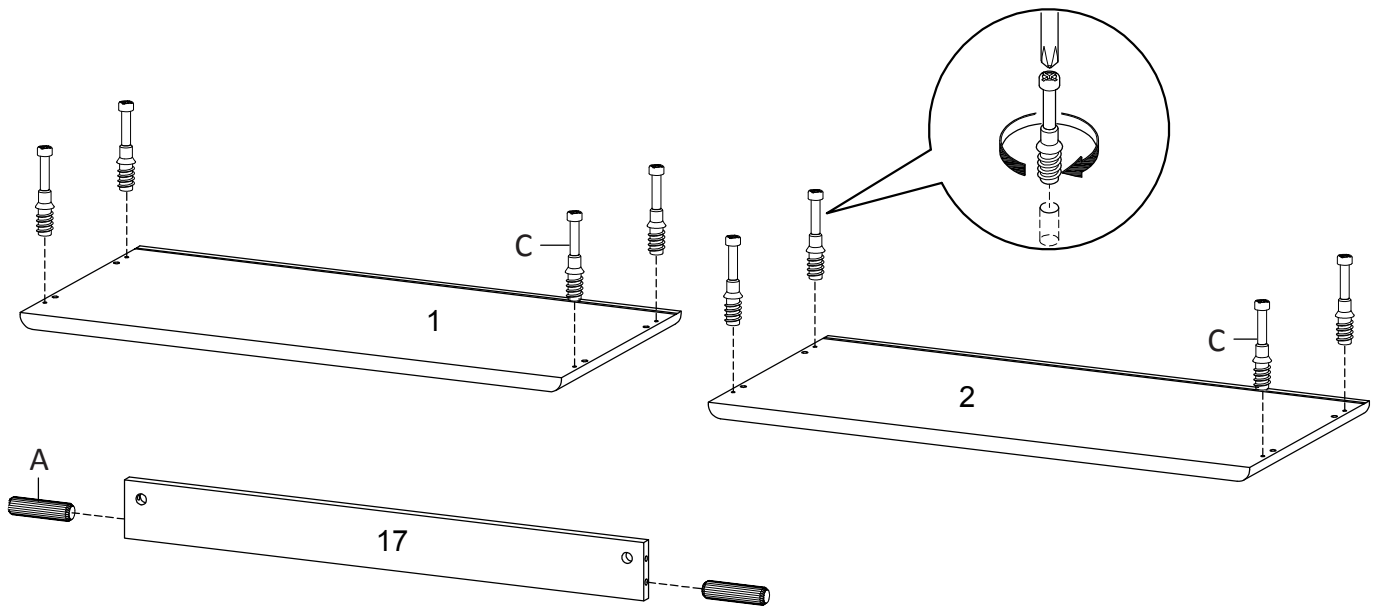

1	Top Board	x1	2	Bottom Board	x1	3	Side Board Left	x1	4	Side Board Right	x1
5	Front Drawer Upper	x1	6	Front Drawer Middle	x1	7	Leg	x2	8	Support Board 1	x2
9	Support Board 2	x2	10	Support Board 3	x1	11	Back Board	x2	12	Side Drawer Left	x3
13	Side Drawer Right	x3	14	Back Drawer	x3	15	Bottom Drawer	x3	16	Support Drawer	x3
17	Support Board 5	x1	18	Front Drawer Bottom	x1						

**STEP 1:**



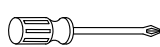

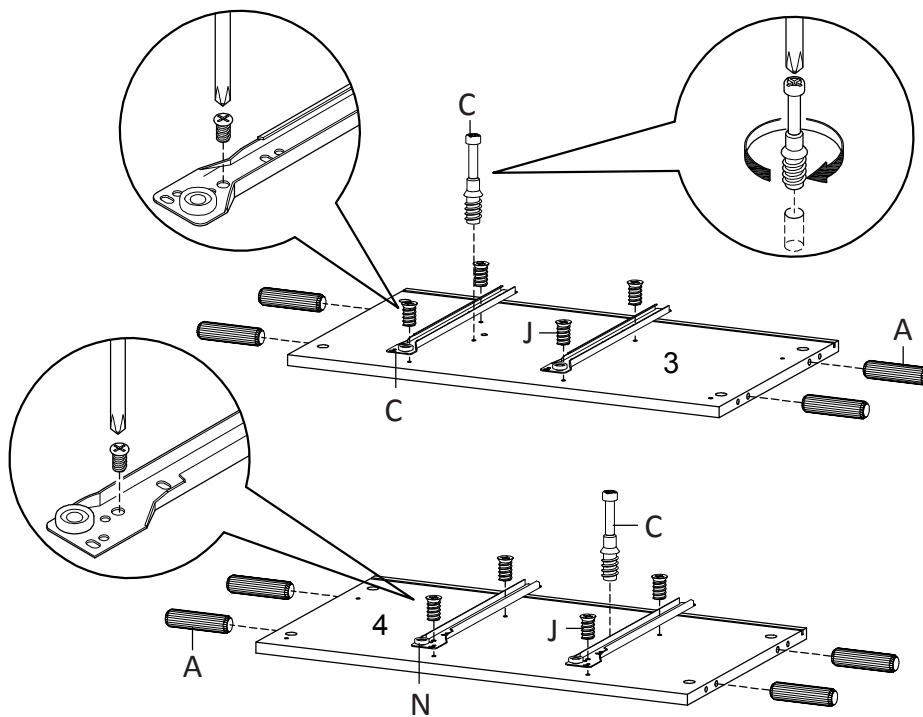

		
Ax2	Cx8	Qx1

Hardware required. Screwdriver not included

**STEP 2:**



				
Ax8	Cx2	Jx8	Nx2	Qx1

Hardware required.  
Screwdriver not included

**STEP 3:**

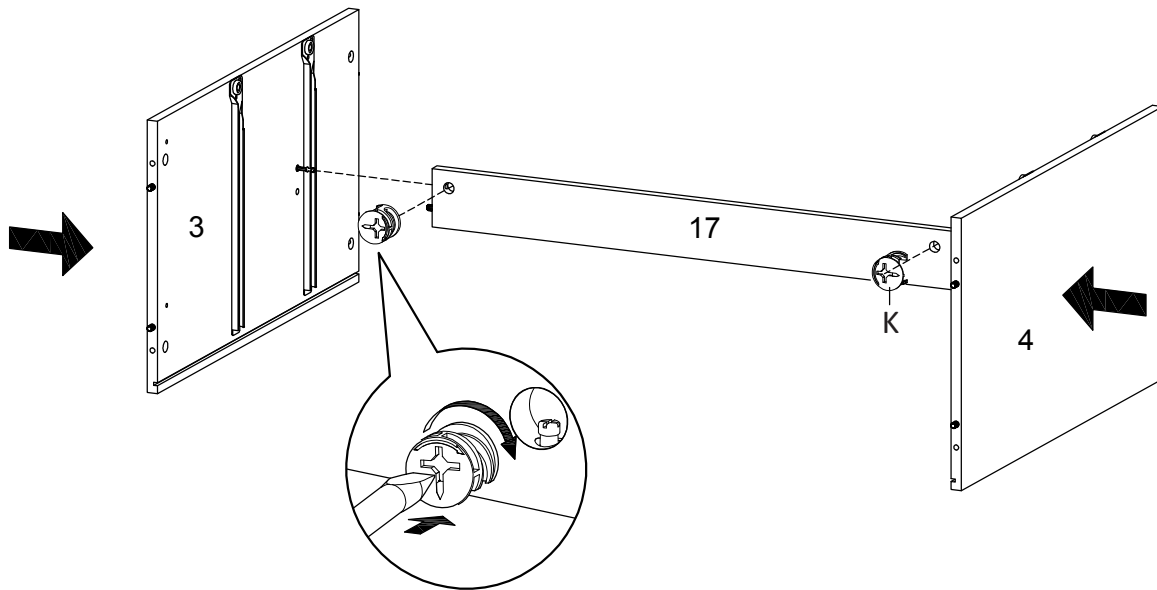

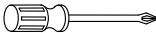
	
Kx2	Qx1

Hardware required. Screwdriver not included

**STEP 4:**

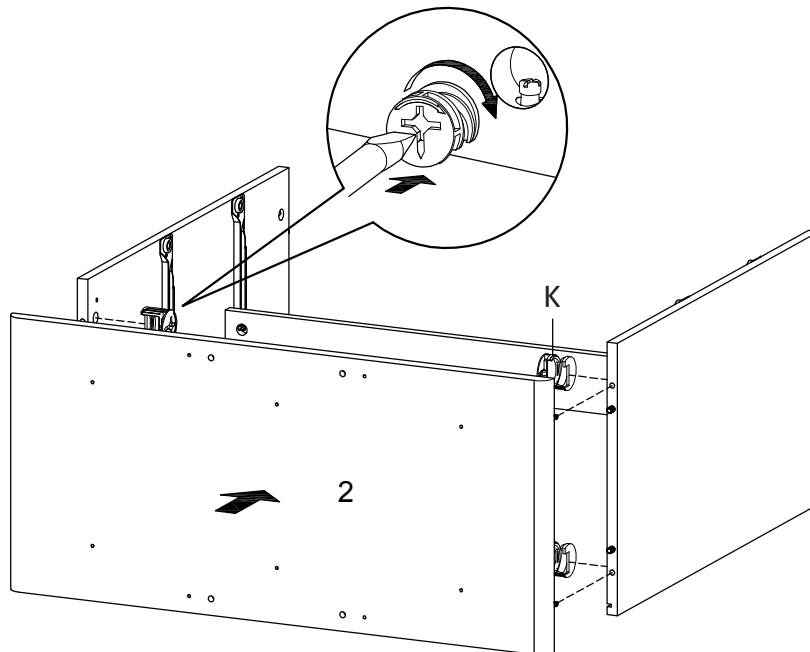

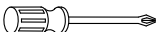
	
Kx4	Qx1

Hardware required. Screwdriver not included

**STEP 5:**

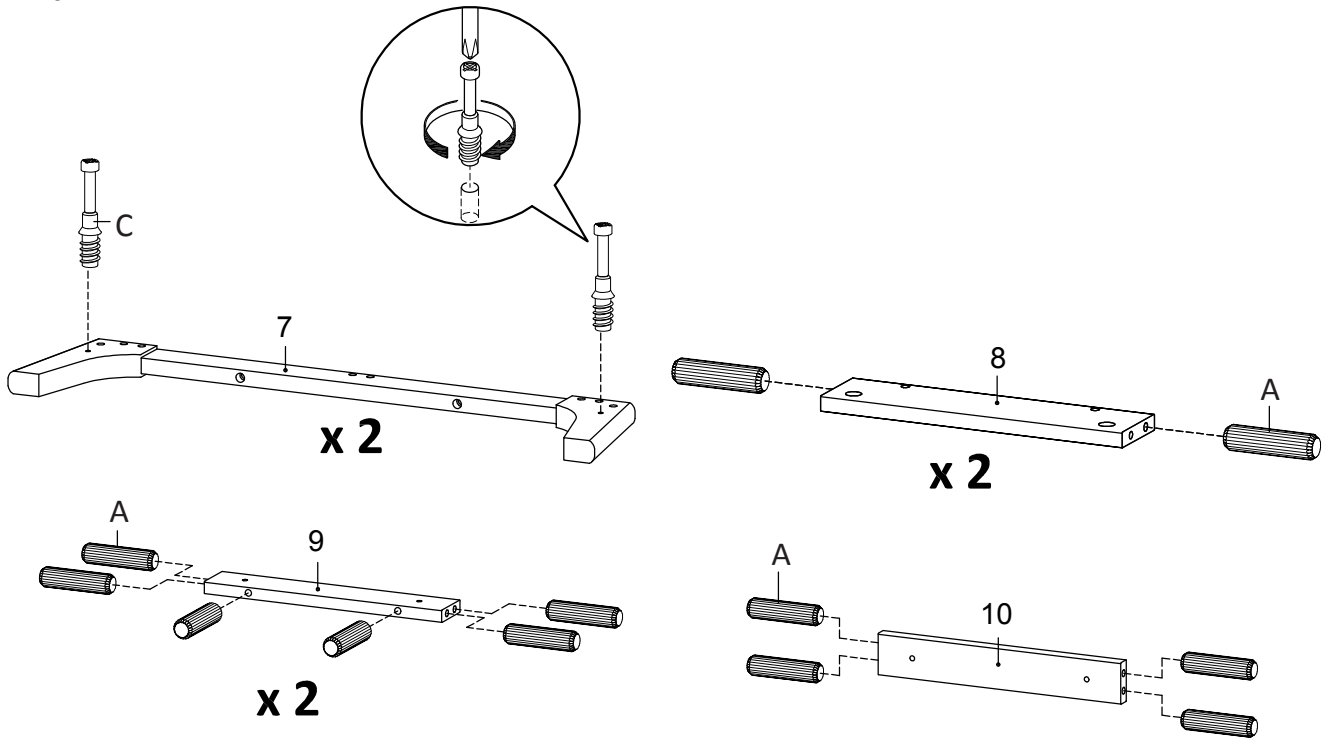

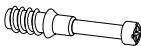
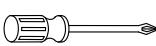
		
Ax20	Cx4	Qx1

Hardware required. Screwdriver not included

**STEP 6:**

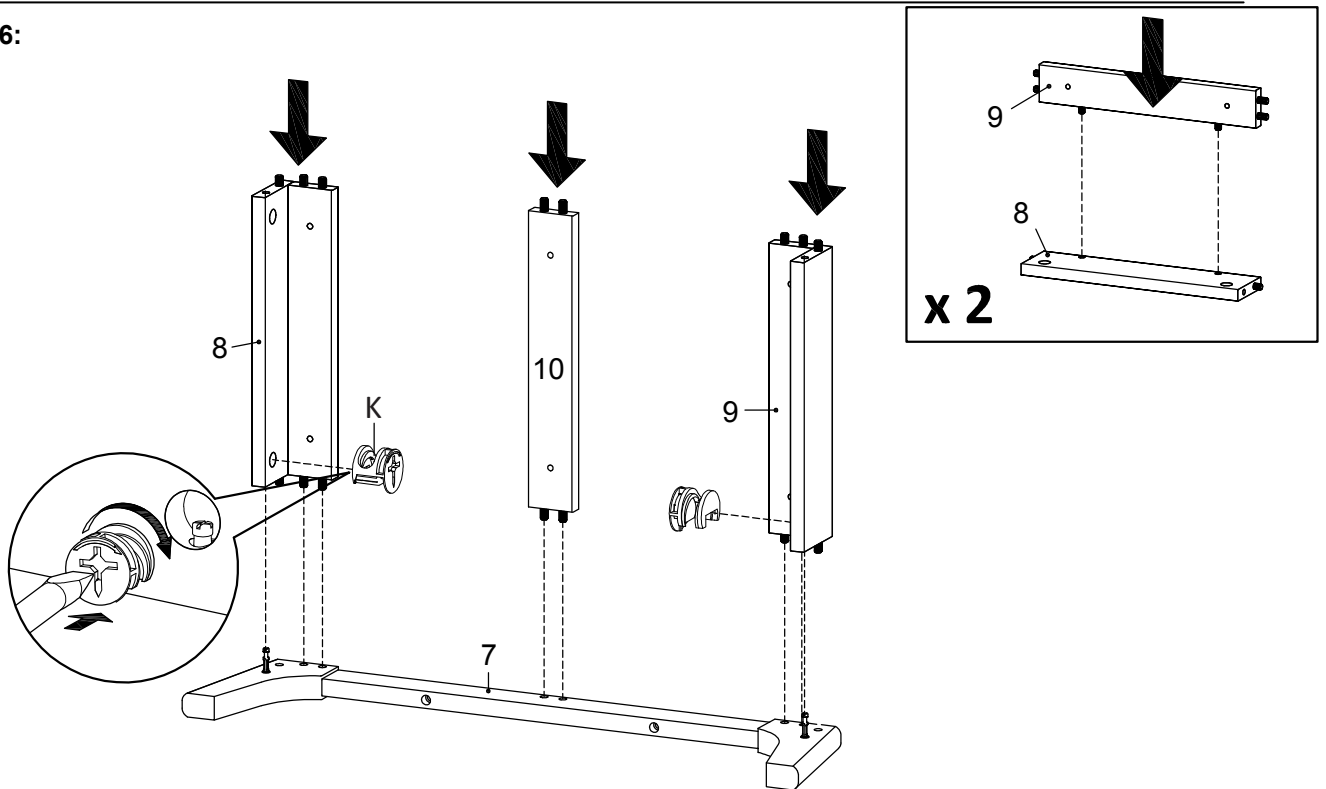

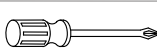
	
Kx2	Qx1

Hardware required. Screwdriver not included

**STEP 7:**

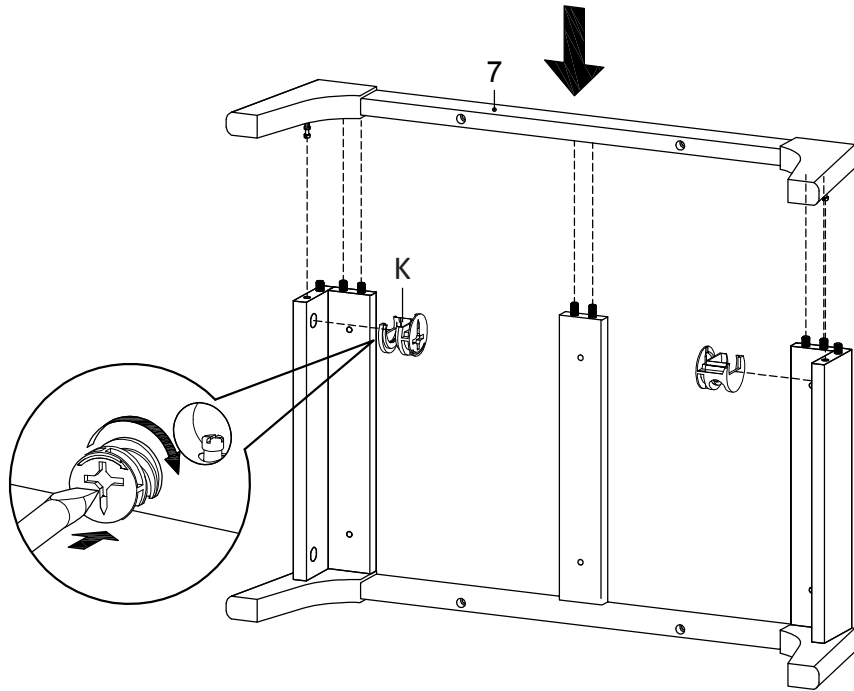

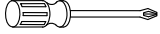
	
Kx2	Qx1

Hardware required. Screwdriver not included

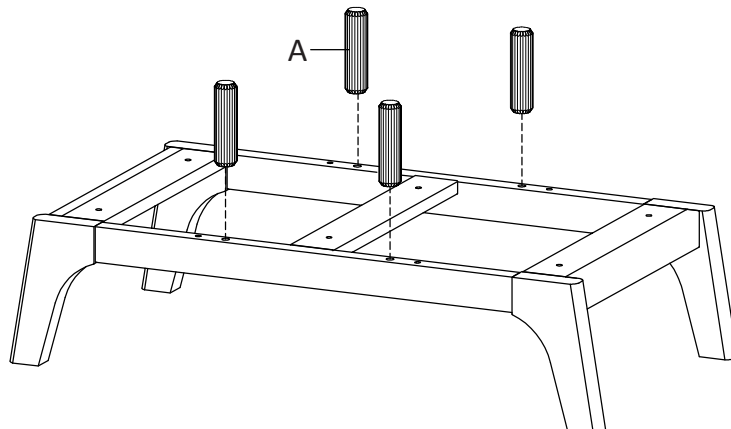

**STEP 8:**

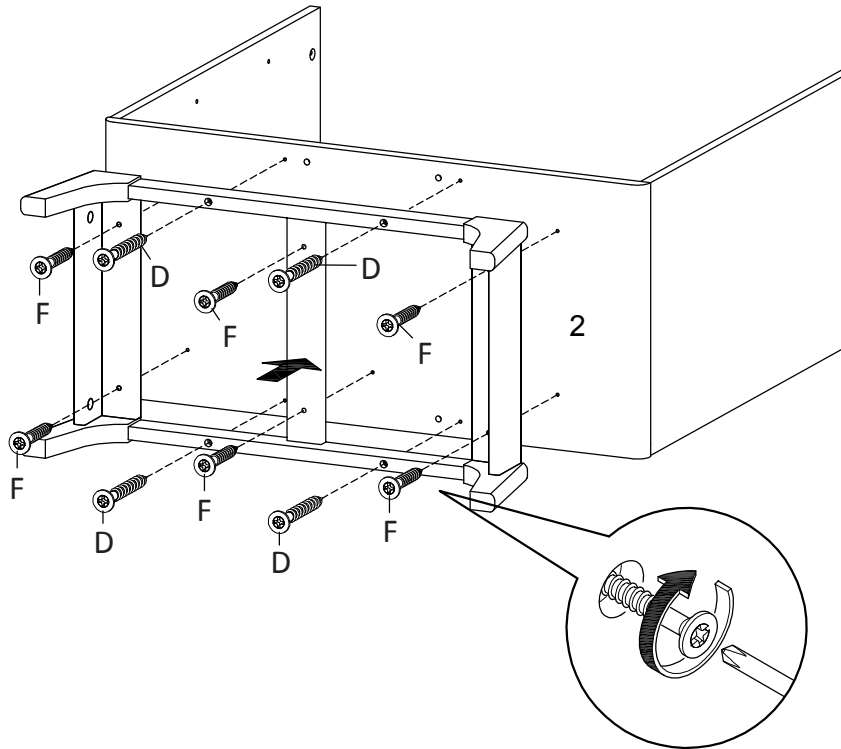

Ax4

**STEP 9:**

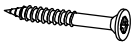

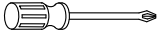
		
Dx4	Fx6	Qx1

Hardware required. Screwdriver not included

**STEP 10:**

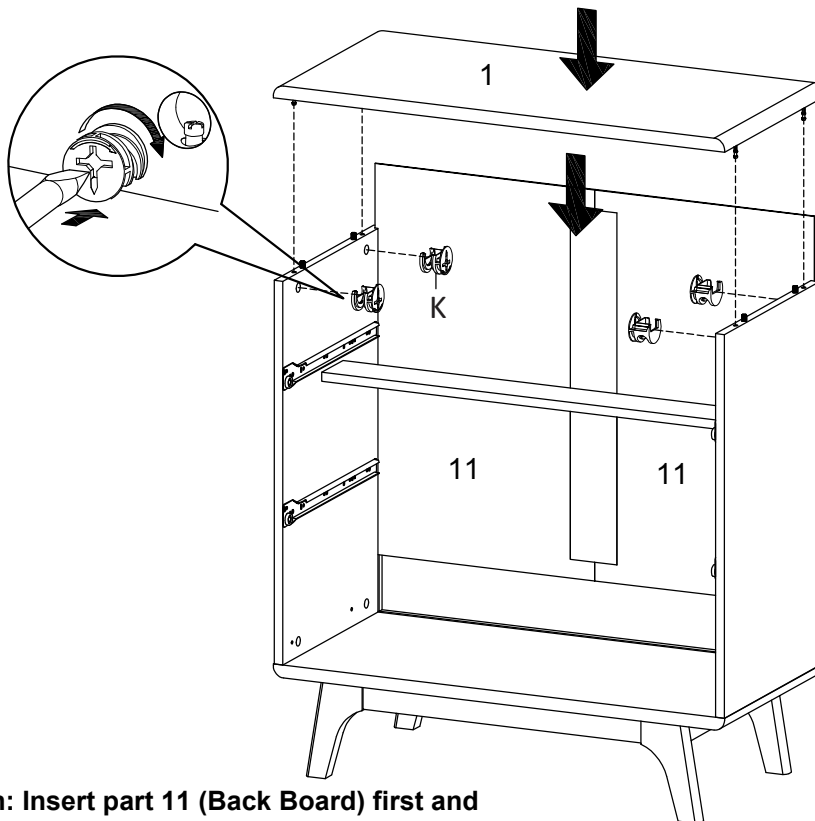

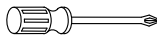

**Attention: Insert part 11 (Back Board) first and then part 1 (Top Board)**

	
Kx4	Qx1

Hardware required.  
Screwdriver not included

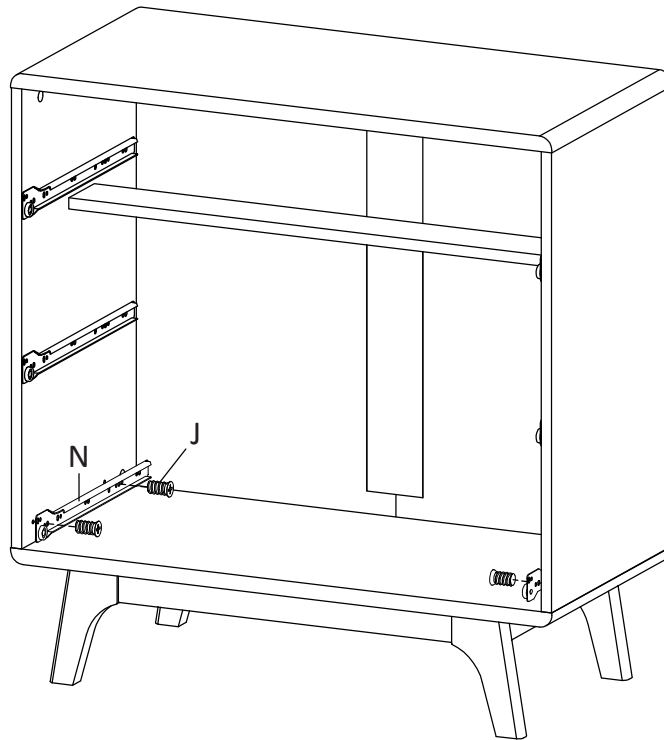
**STEP 11:**

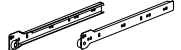

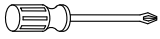
		
Nx1	Jx4	Qx1

Hardware required. Screwdriver not included

**STEP 12:**

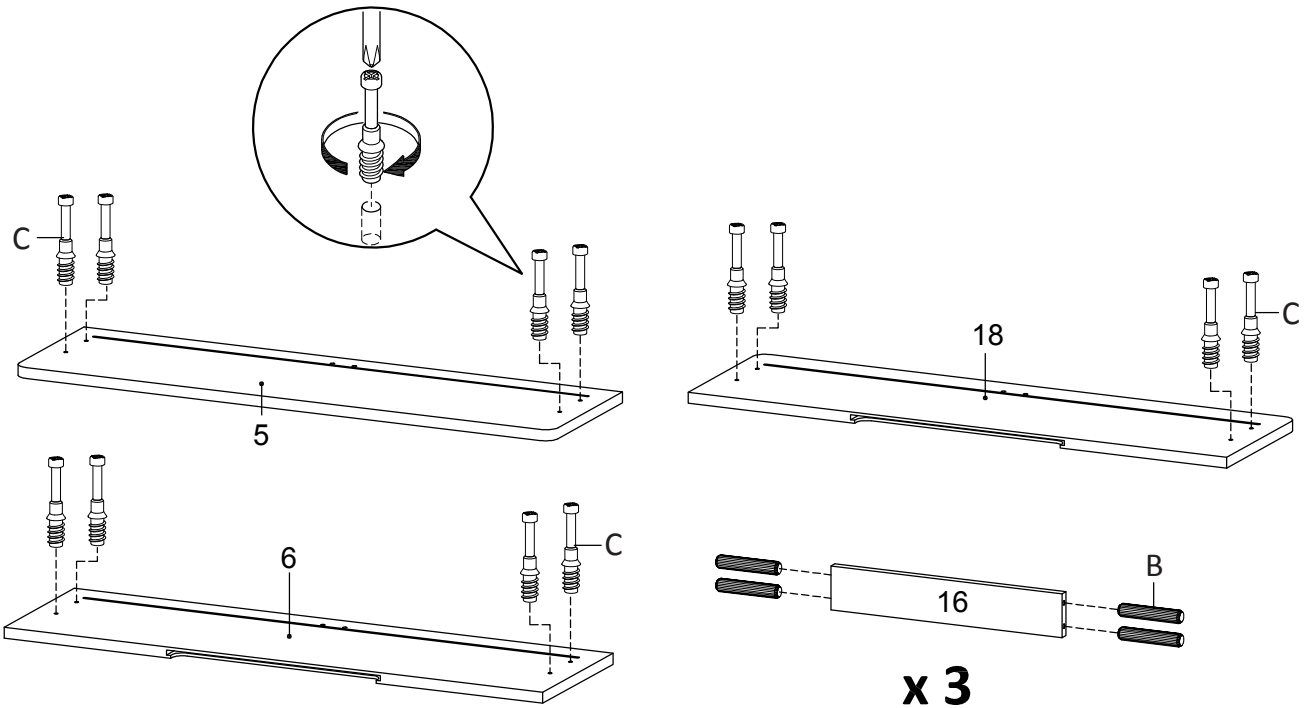

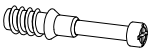
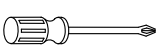
		
Bx12	Cx12	Qx1

Hardware required. Screwdriver not included

**STEP 13:**

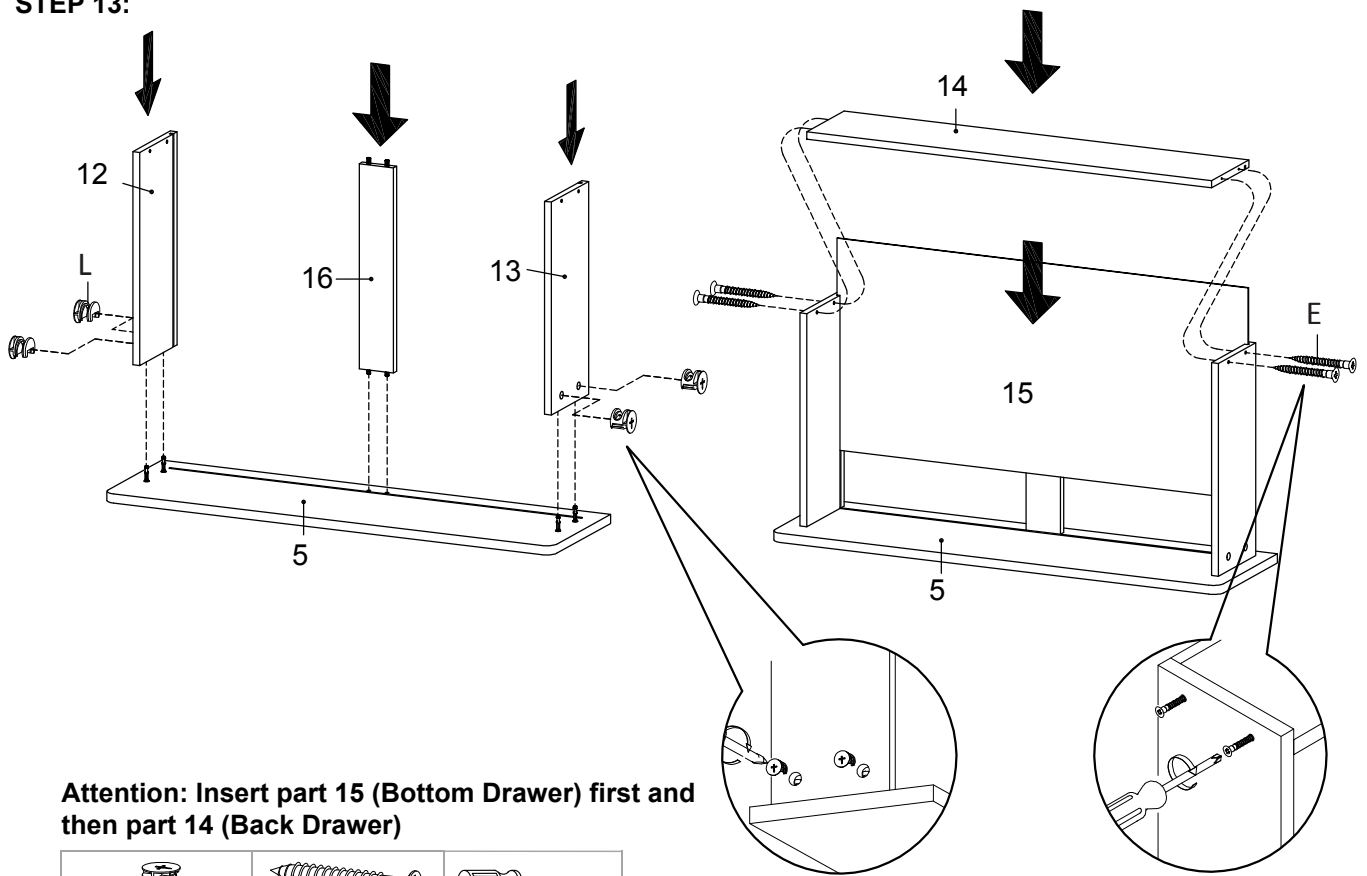

**Attention: Insert part 15 (Bottom Drawer) first and then part 14 (Back Drawer)**

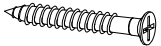
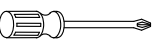

		
Lx4	Ex4	Qx1

Hardware required. Screwdriver not included

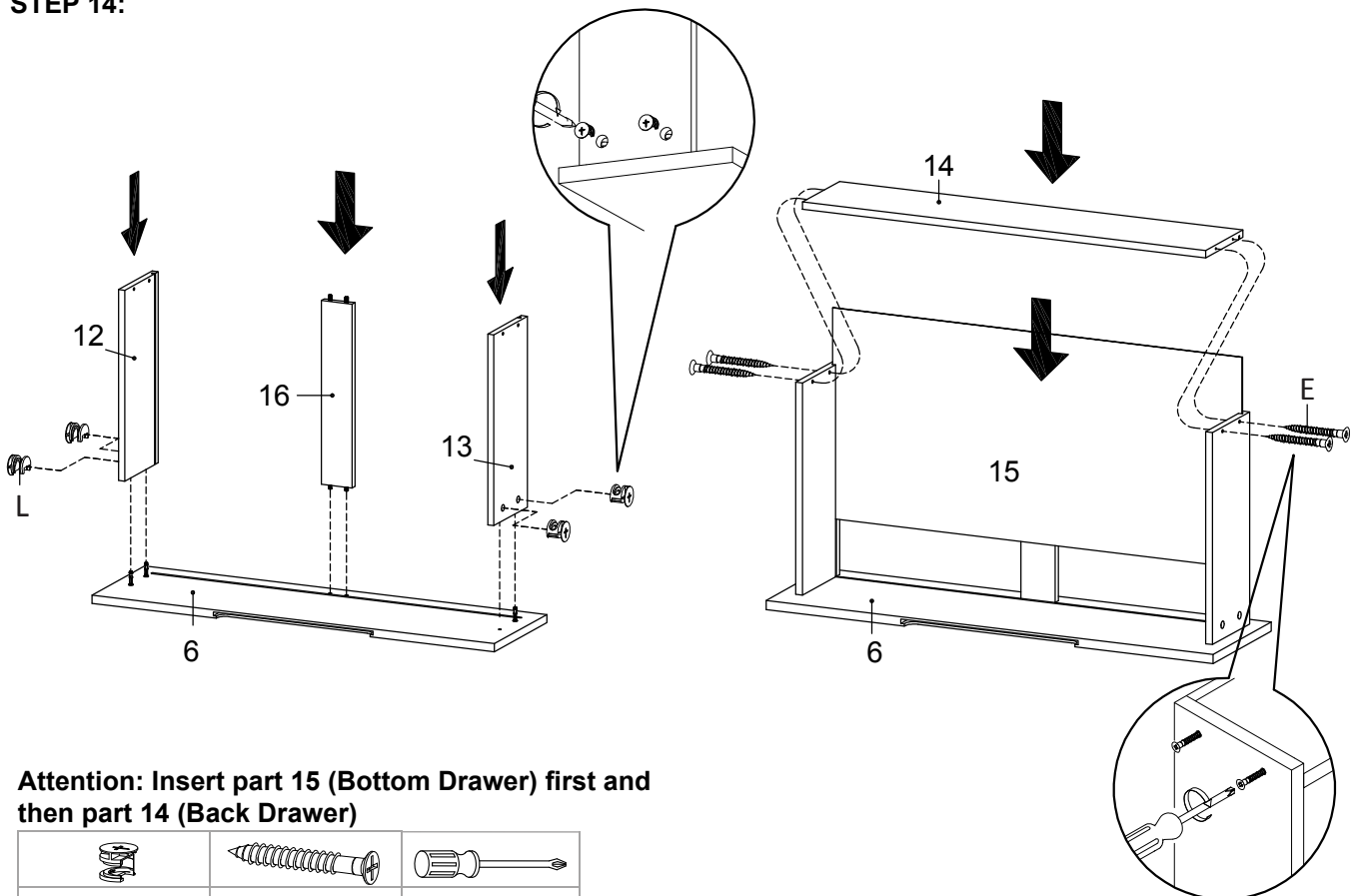
**STEP 14:**



**Attention: Insert part 15 (Bottom Drawer) first and then part 14 (Back Drawer)**

		
Lx4	Ex4	Qx1

Hardware required. Screwdriver not included

**STEP 15:**

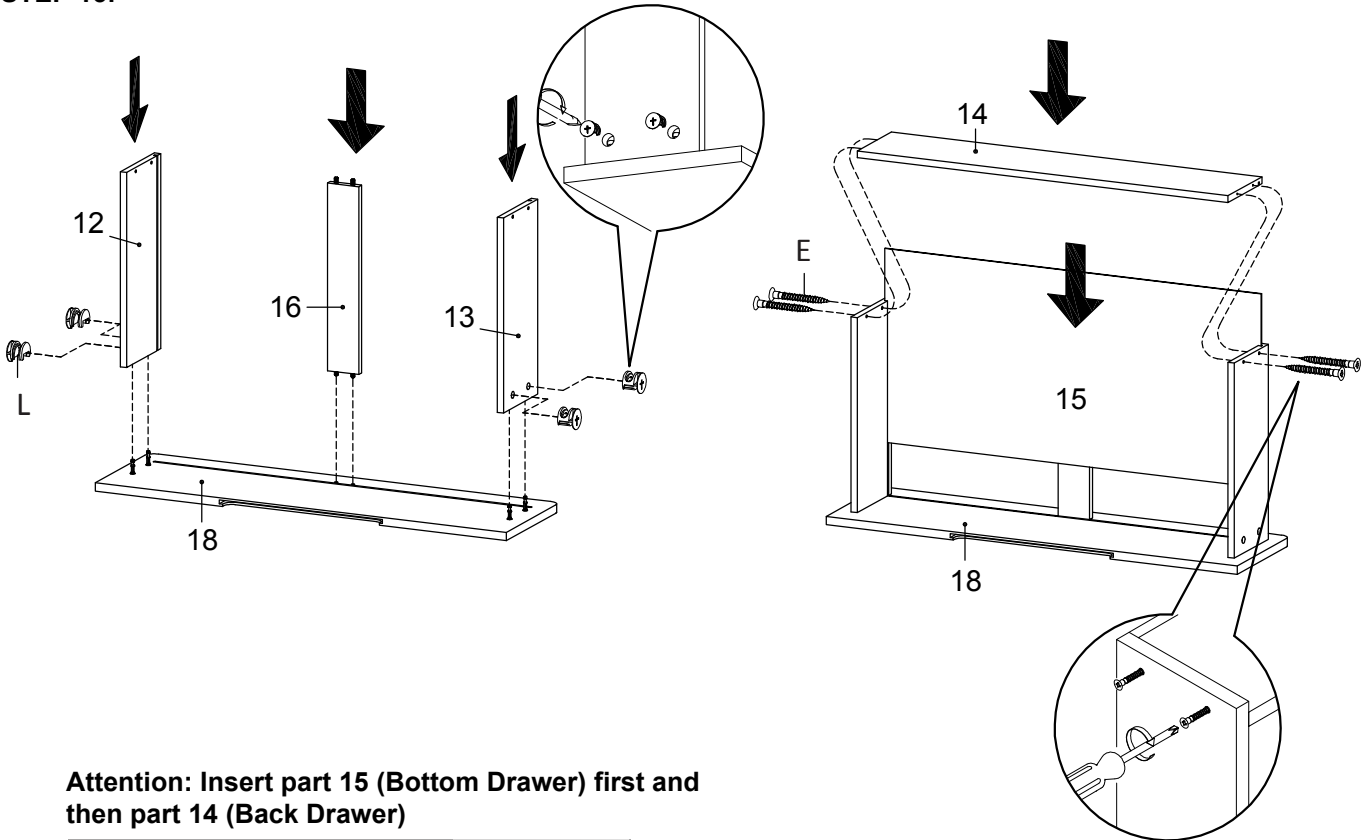

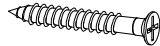
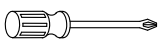

**Attention: Insert part 15 (Bottom Drawer) first and then part 14 (Back Drawer)**

		
Lx4	Ex4	Qx1

Hardware required. Screwdriver not included

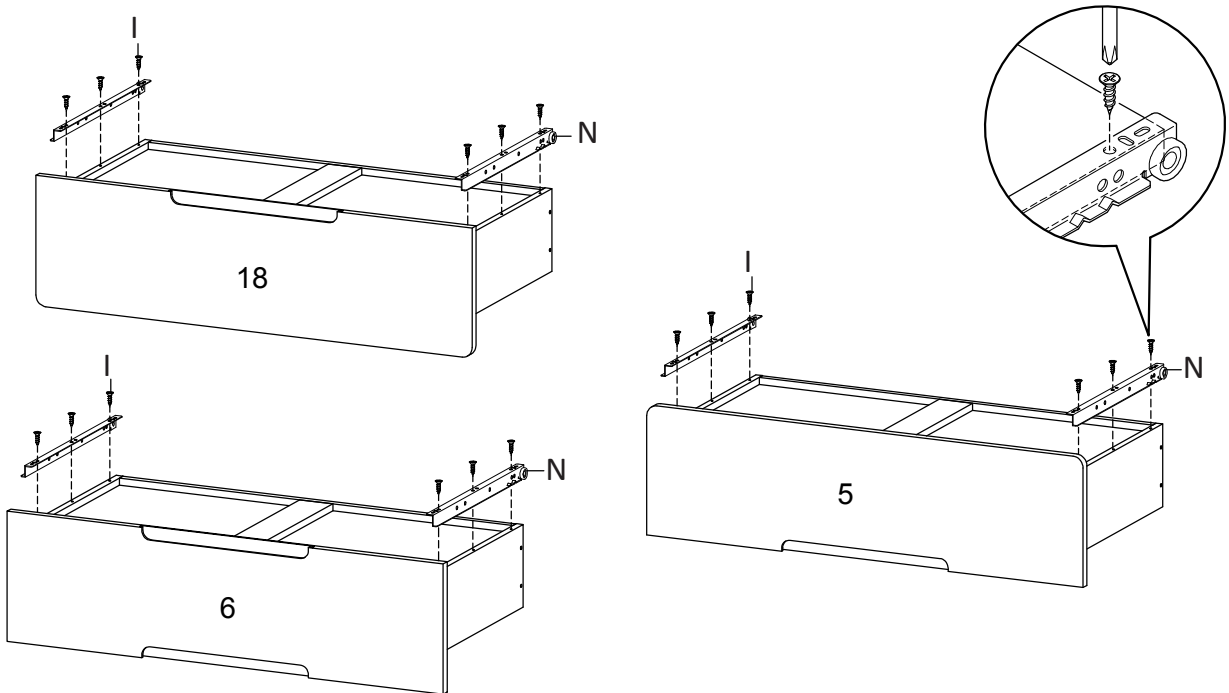
**STEP 16:**

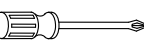

		
Nx1	Ix18	Qx1

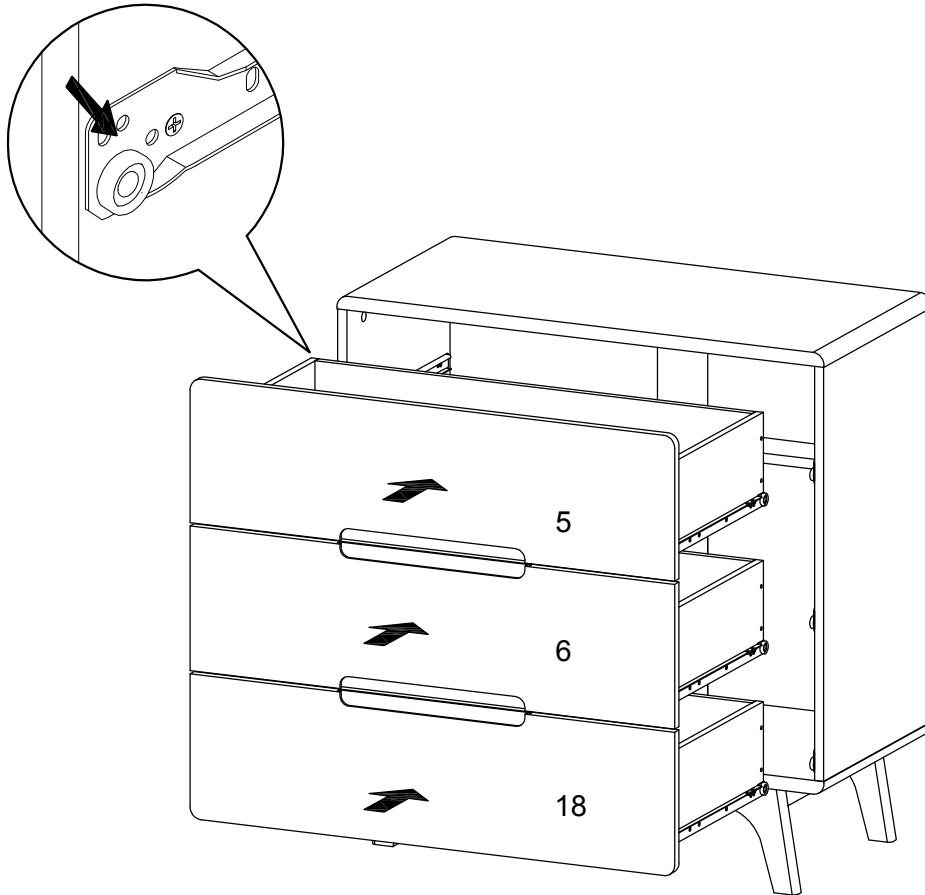

Hardware required.  
Screwdriver not included

**STEP 17:**

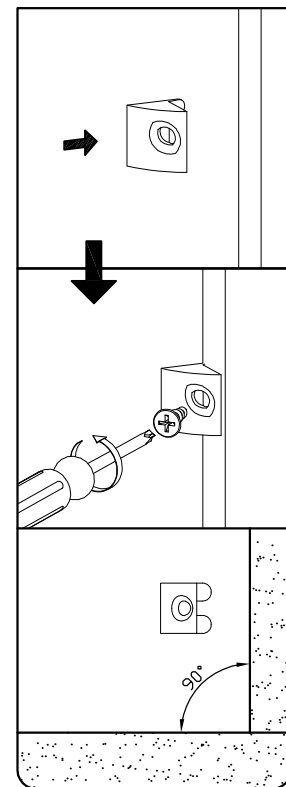
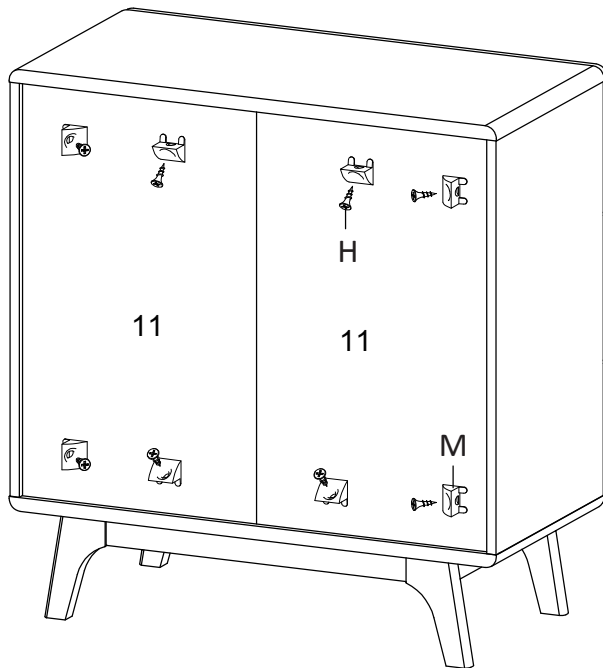

**STEP 18:**



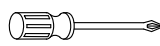

		
Mx8	Hx8	Qx1

Hardware required. Screwdriver not included

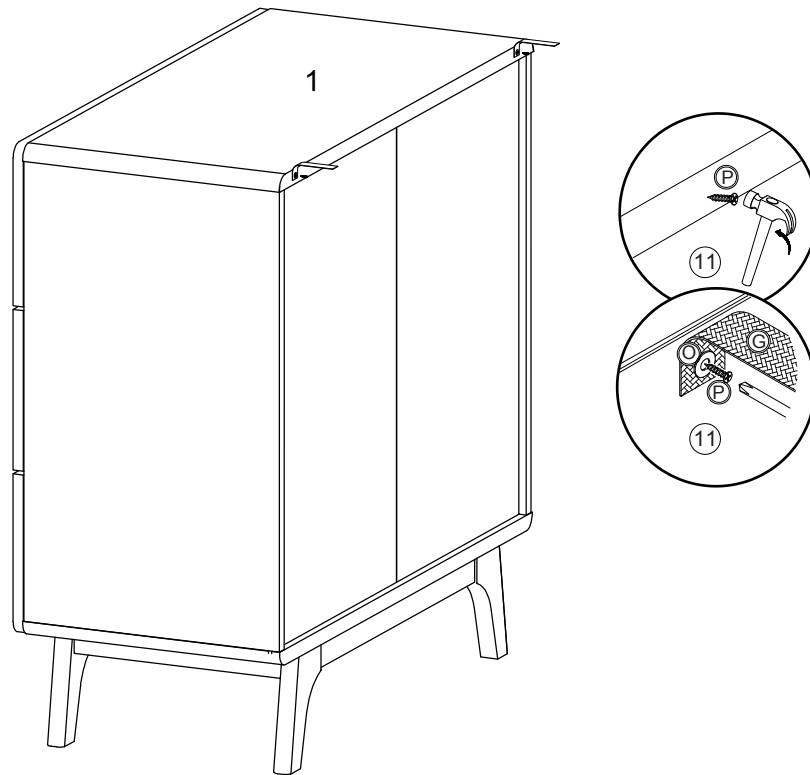
**STEP 19:**

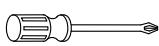

			
Gx2	Ox2	Px2	Qx1

Hardware required.  
Screwdriver not included

**STEP 20:**



**Assembly is complete.**