



## FORNO COMMERCIALE GAS RANGE OVEN

**FCMGR0093-24(4 BURNER TOP)**  
**FCMGR0093-36(6 BURNER TOP)**  
**FCMGR0093-60(10 BURNER TOP)**



ANSI Z83.11 • CSA 1.8-(2016) Food Service Equip.  
 Conforms to ANSI STD Z83.11-2016  
 Certified to CSA STD 1.8-2016 Food Service Equip.  
 CONFORMS TO NSF/ANSI 4:2020

## INSTRUCTION MANUAL

Read these instructions carefully before using your appliance, and keep it carefully.  
 If you follow the instructions, your appliance will provide you with many years of good service.

## TABLE OF CONTENTS

Customer Care	4
Important For Your Safety	5
Installation, Operation and Care	6
Troubleshooting Guide	15
Conversion Kit Instructions	16
Warranty	19

# FORNO COMMERCIALE GAS RANGE OVEN



FCMGR0093-24



FCMGR0093-36



FCMGR0093-60

## LINE DRAWING

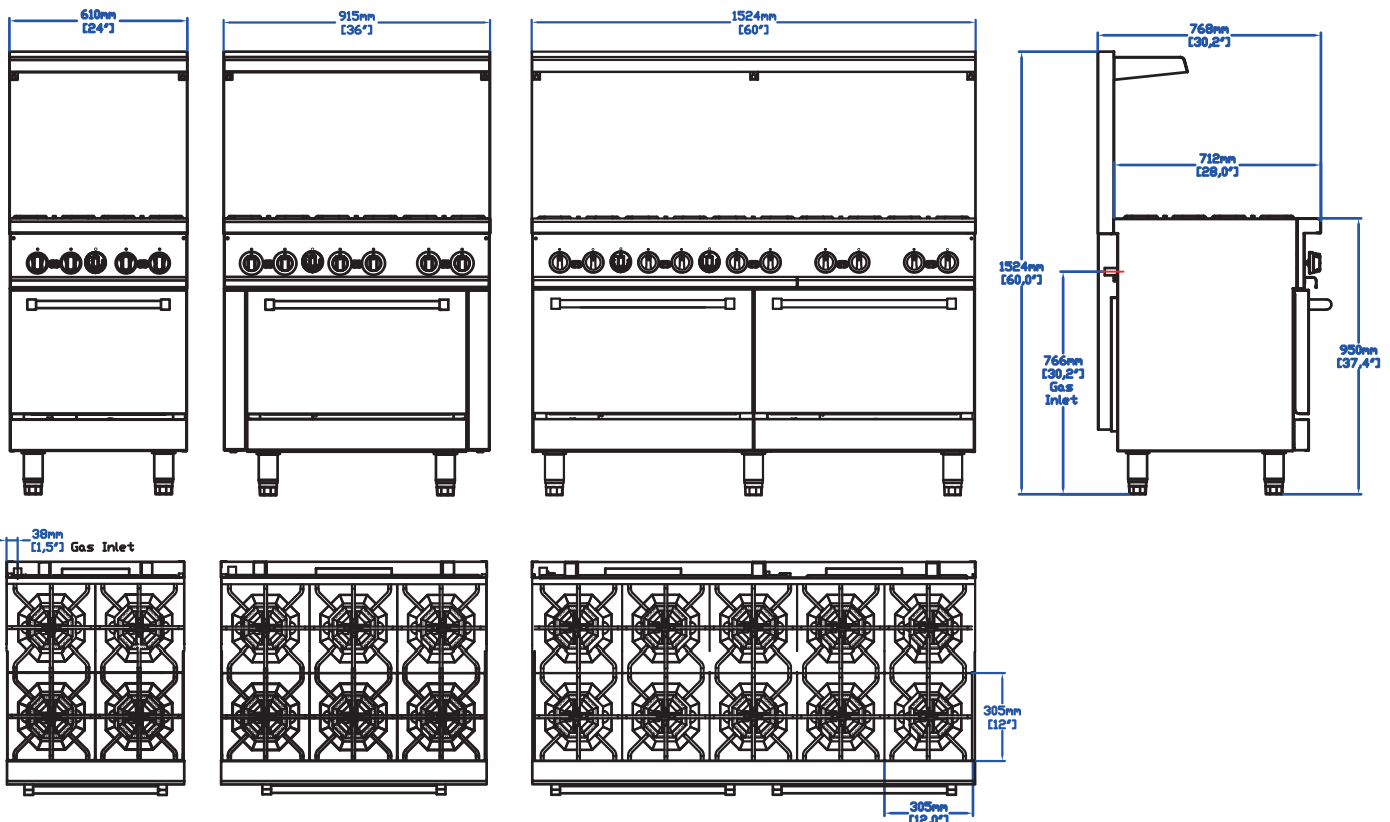

## Customer Care

Thank you for purchasing a Forno product. Please read the entire instruction manual before operating your new appliance for the first time. Whether you are an occasional user or an expert, it will be beneficial to familiarize yourself with the safety practices, features, operation and care recommendations of your appliance.

Both the model and serial number are listed inside the product. For warranty purposes, you will also need the date of purchase .

Record this information below for future reference.

Product Information	Service Information
Model Number : _____	
Serial Number : _____ _____ _____ _____ _____ _____ _____ _____	
Date of Purchase : _____	
Purchase Address And Phone: _____ _____ _____	

**Service Information**

Use these numbers in any correspondence or services calls concerning your product.

If you received a damaged product, immediately contact Forno.

To save time and money, before you call for serviced, check the troubleshooting guide. It listed the causes of minor operation problems that you can correct yourself.



*“Need some quick help? Simply scan the qr code and get access to our fast support form. We’re always here to assist you with any questions or concerns you may have. So, don’t hesitate to reach out!”*

### Services in Canada and Untied States

Keep the instruction manual handy to answer your questions. If you don’t understand something or need more assistance, please visit our website for fast support. Please provide us your name, number, address,serial number of the product that troubleshooting, proof of purchase, and a short description of the issue. A customer service representative will contact you as soon as possible. All warranty work needs to be authorized by FORNO customer service. All our authorized service providers are carefully selected and rigorously trained by us.

# IMPORTANT FOR YOUR SAFETY

THIS MANUAL HAS BEEN PREPARED FOR PERSONNEL QUALIFIED TO INSTALL GAS EQUIPMENT, WHO SHOULD PERFORM THE INITIAL FIELD START-UP AND ADJUSTMENTS OF THE EQUIPMENT COVERED BY THIS MANUAL.

POST IN A PROMINENT LOCATION THE INSTRUCTIONS TO BE FOLLOWED IN THE EVENT THE SMELL OF GAS IS DETECTED. THIS INFORMATION CAN BE OBTAINED FROM THE LOCAL GAS SUPPLIER.

## **NOTICE**

*IN THE EVENT A GAS ODOR IS DETECTED.  
SHUTDOWN UNITS AT MAIN SHUTOFF VALVE  
AND CONTACT THE LOCAL GAS COMPANY  
OR GAS SUPPLIER FOR SERVICE.*

# Installation, Operation and Care:

## PLEASE KEEP THIS MANUAL FOR FUTURE REFERENCE

### GENERAL

Ranges are produced with quality workmanship and material. Proper installation, usage and maintenance of your range will result in many years of satisfactory performance.

Suggests that you thoroughly read this entire manual and carefully follow all of the instructions provided.



THIS APPLIANCE IS EQUIPPED FOR NATURAL GAS, for conversion to LP gas please see gas conversion instruction manual attached. Orifices necessary for LP (propane) (natural) conversion are provided. Please refer to page 3 the orifice size list when you do gas conversion

## INSTALLATION

### UNCRATING

This range was inspected before leaving the factory. The transportation company assumes full responsibility for safe delivery upon acceptance of the shipment. Immediately after unpacking, check for possible shipping damage. If the range is found to be damaged, save the packaging material and contact the carrier within 15 days of delivery.

Uncrate unit carefully and place in a work-accessible area as near to its final installed position as possible. Remove all shipping wire and wood blocking.

Before installing, check the type of gas supply (natural or propane) to make sure they agree with the specifications on the rating plate located on the inside of the lower kick panel. If the supply and equipment requirements do not agree, do not proceed with the installation. Contact your dealer or company immediately.

### LOCATION

The appliance must be installed under a ventilation hood.

The equipment area must be kept free and clear of combustible substances.

The range, when installed, must have a minimum clearance from combustible construction of 12" (304 mm) at the sides and 10" (253 mm) at the rear. Clearance from non-combustible construction is 0" at the sides and 6" (152 mm) at the rear.

The installation location must allow adequate clearances for servicing and proper operation. A minimum front clearance of 40" (1016 mm) is required.

The range must be installed so that the flow of combustion and ventilation air will not be obstructed. Adequate clearance for air openings into the combustion chamber must be provided. Make sure there is an adequate supply of air in the room to allow for combustion of the gas at the burners.

For adapt to the ground level, should be adjust four foot.

## **INSTALLATION CODES AND STANDARDS**

Ranges must be installed in accordance with:

### **In the United States of America:**







- 1.State and local codes.
- 2.National Fuel Gas Code, ANSI/Z223.1 (latest edition). Copies may be obtained from The American Gas Association, Inc., 1515 Wilson Blvd., Arlington, VA22209.





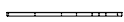



### **In Canada:**

- 1.Local codes.
- 2.CSA B149.1 Natural Gas and Propane Installation Code.
- 3.CSA C22.1 Canadian Electric Code.
- 4.CSA C22.2 Canadian Electric Code.

The above are available from the Canadian Standard Association, 5060 Spectrum Way, Suite 100, Mississauga, Ontario, Canada L4W 5N6.

**Backsplash**

No.	Accessory	Q'TY		Fig
		24"/36"	48"/60"	
1	Top shelf plate	1	1	
2	Backsplash assembly	1	1	
3	Backsplash column support	2	3	
4	FCMGR0093-24 screw	10	10	
5	FCMGR0093-36 screw	30	30	
6	FCMGR0093-60 screw	40	40	

No.	Accessory	Q'TY		Fig
		24"/36"	48"/60"	
7	FCMGR0093-24 Top burner orifice	4		
8	FCMGR0093-36 Top burner orifice	6		
9	FCMGR0093-60 Top burner orifice		10	
10	Oven orifice	1	2	
11	Oven pilot orifice	1	2	
12	Regulators	1	1	

The standard Restaurant Range is equipped with a 23" (600 mm) high backsplash and shelf.

1. Remove the backsplash components from the crating materials.
2. Assemble the required components as shown.

For 24" & 36"

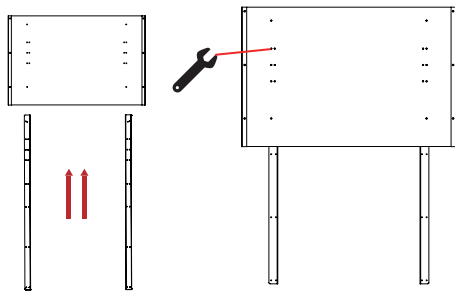

3. Tighten the four screws to secure the shelf.

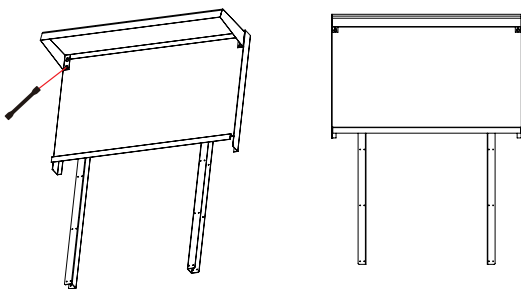

4. Lift the assembly up, sliding the channels into the space provided at the rear of the range.

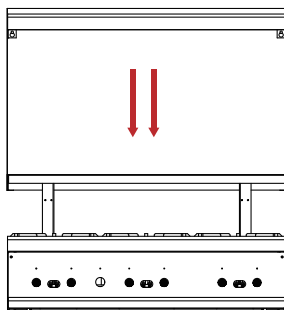

1. Remove the backsplash components from the crating materials.
2. Assemble the required components as shown.

For 48" & 60"

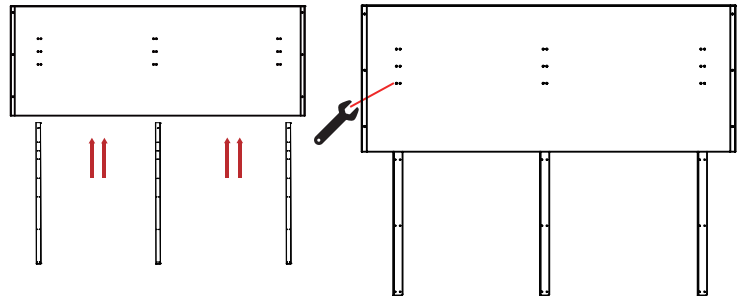

3. Tighten the nut to secure the post

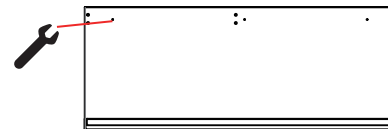

4. Tighten the four screws to secure the shelf.

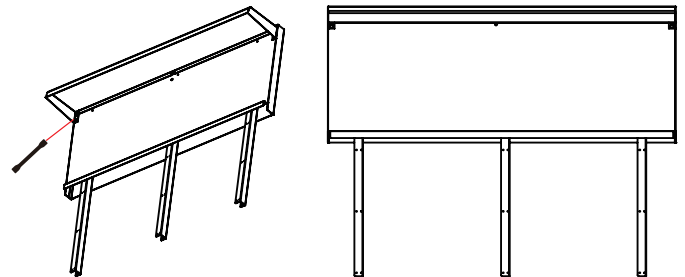

5. Lift the assembly up, sliding the channels into the space provided at the rear of the range.

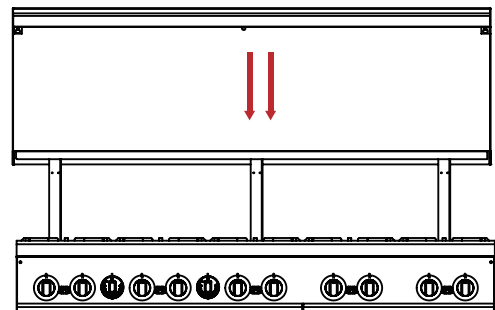

## Installation, Operation and Care(continued)

5. Install Four #10 sheet metal screws  
(2 to each channel leg)

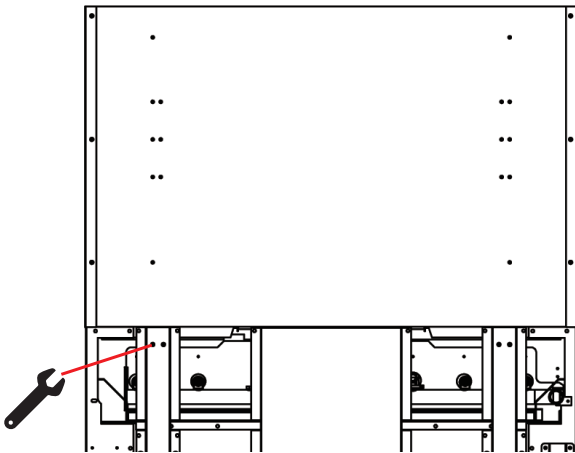

5. Install Eighteen #10 sheet metal screws  
(6 to each channel leg)

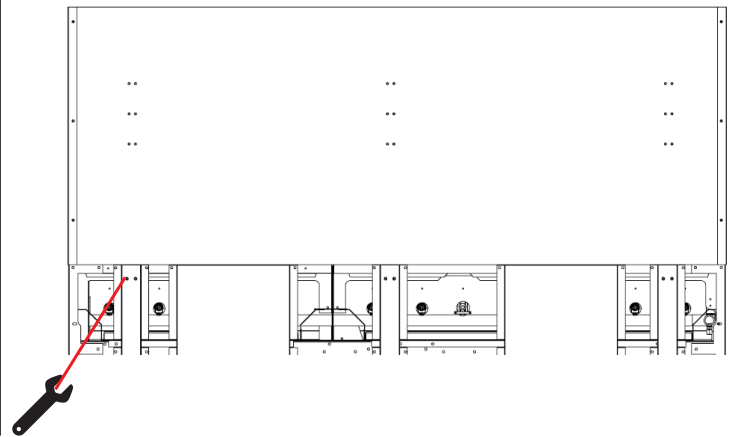

## LEVELING

Check the leveling of the range. Place a level inside the oven cavity across the oven rack(s). Level front-to-back and side-to-side.

To adjust the leveling, tilt the range to one side and, using channel locks, unscrew the adjustable leg insert as required. Repeat this procedure as necessary for each leg.

Optional casters for this range are of the non-adjustable type. Therefore, the floor must be level. If floor surface is not level, the range will experience cooking problems.

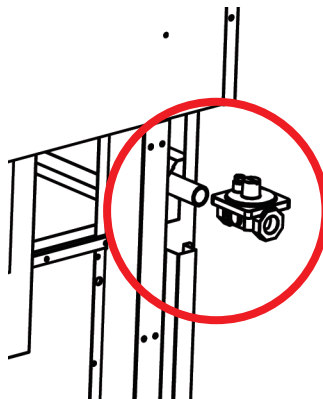

## GAS CONNECTIONS

**CAUTION: All gas supply connections and any pipe joint compound used must be resistant to the action of propane gases.**

Each range is factory-equipped for the type gas specified on the rating plate. The installation gas connection is a 3/4" (19 mm) 14 FPT ANSI schedule #40 standard pipe. Connect gas supply. Make sure the pipes are clean and free of obstructions. Codes require that a gas shutoff valve be installed in the gas line ahead of the range. Standard ranges are equipped with fixed burner orifices which coincide with installation elevation. Install the gas pressure regulator.

## **Installation, Operation and Care(continued)**

---

Before installing, ensure that regulator supplied agrees with rating plate gas supply. The gas pressure regulator is NOT factory installed. The regulator for this gas type is sealed within a plastic bag attached to the oven rack inside the oven cavity. This regulator must be field installed by a qualified installer.

Natural gas regulators are preset for 5" W.C. (Water Column) (1.25 kPa); propane gas regulators for 10.0" W.C. (2.5 kPa)

1. Locate 3/4" (19 mm) gas connection pipe extending from rear of range.
2. Cover pipe threads with leak sealant.
3. Screw regulator hand-tight onto pipe with regulator arrow pointing towards range body back .
4. Using pipe wrench, tighten regulator securely in an upright position .

The arrow on the regulator shows the direction of the gas flow. The pressure regulator must be mounted horizontally to ensure proper preset outlet pressure. If the regulator is installed in any other position, the outlet pressure must be reset for proper operation.

A leak limiter is supplied with every regulator to allow excess gas pressure to escape. Do not obstruct leak limiter on gas pressure regulator, as obstruction may cause regulator to malfunction.

**WARNING: PRIOR TO LIGHTING, CHECK ALL JOINTS IN THE GAS SUPPLY LINE FOR LEAKS. USE SOAP AND WATER SOLUTION. DO NOT USE AN OPEN FLAME.**

After piping has been checked for leaks, all piping receiving gas should be fully purged to remove air. Before operation, verify thermocouple is securely seated in the safety valve. The thermocouple should be tightened a 1/4 turn past finger tight. DO NOT OVERTIGHTEN. Over-tightening may damage the thermocouple or safety magnet.

### **TESTING THE GAS SUPPLY SYSTEM**

When gas supply pressure exceeds 1/2 psig (3.45 kPa), the range and its individual shutoff valve must be disconnected from the gas supply piping system.

When gas supply pressure is 1/2 psig(3.45kPa) or less, the range should be isolated from the gas supply system by closing its individual manual shutoff valve until the range is ready for start-up.

#### **WARNING**

This product can expose you to chemicals including [Lead & Lead Compounds], which is [are] known to the State of California to cause cancer, birth defects and / or reproductive harm. To minimize exposure to these substances. Always operate this unit according the Owner' s Manual, and ensure that you provide proper ventilation. For more information go to [www.P65Warnings.ca.gov](http://www.P65Warnings.ca.gov)

**FLUE CONNECTIONS DO NOT** obstruct the flow of flue gases from the flue located on the rear of the range. It is recommended that the flue gases be ventilated to the outside of the building through a ventilation system installed by qualified personnel.

From the termination of the flue to the filters of the hood venting system, a minimum clearance of 18" (457 mm) must be maintained.

Information on the construction and installation of ventilating hoods may be obtained from the standard for the "Removal of Vapors from Commercial Cooking Equipment", NFPA No. 96 (latest edition), available from The National Fire Protection Association, Batterymarch Park, Quincy, MA 02269.

## **OPERATION**

**WARNING:** THE RANGE AND ITS PARTS ARE HOT. BE VERY CAREFUL WHEN OPERATING, CLEANING OR SERVICING THE RANGE.

## **LIGHTING AND SHUTTING DOWN PILOTS**

All adjustment procedures associated with pilot lighting must be performed **by an authorized vender installation or service person.**

## **INSTALLATION CODES AND STANDARDS**

1. Turn main gas supply ON.
2. Wait 30 seconds and, using a taper, light the open top pilot
3. If pilot fails to light, turn main gas supply OFF. Wait 5 minutes and repeat the above procedures.
4. Turn one open top burner valve ON to remove air from the gas line. Turn burner OFF when gas begins to flow.

Turn burner valve OFF; pilot will off.

## **Complete Shutdown**

1. Turn burner valve “★” pilot will remain lit.
2. Turn main gas supply OFF. Include main flame and pilot.

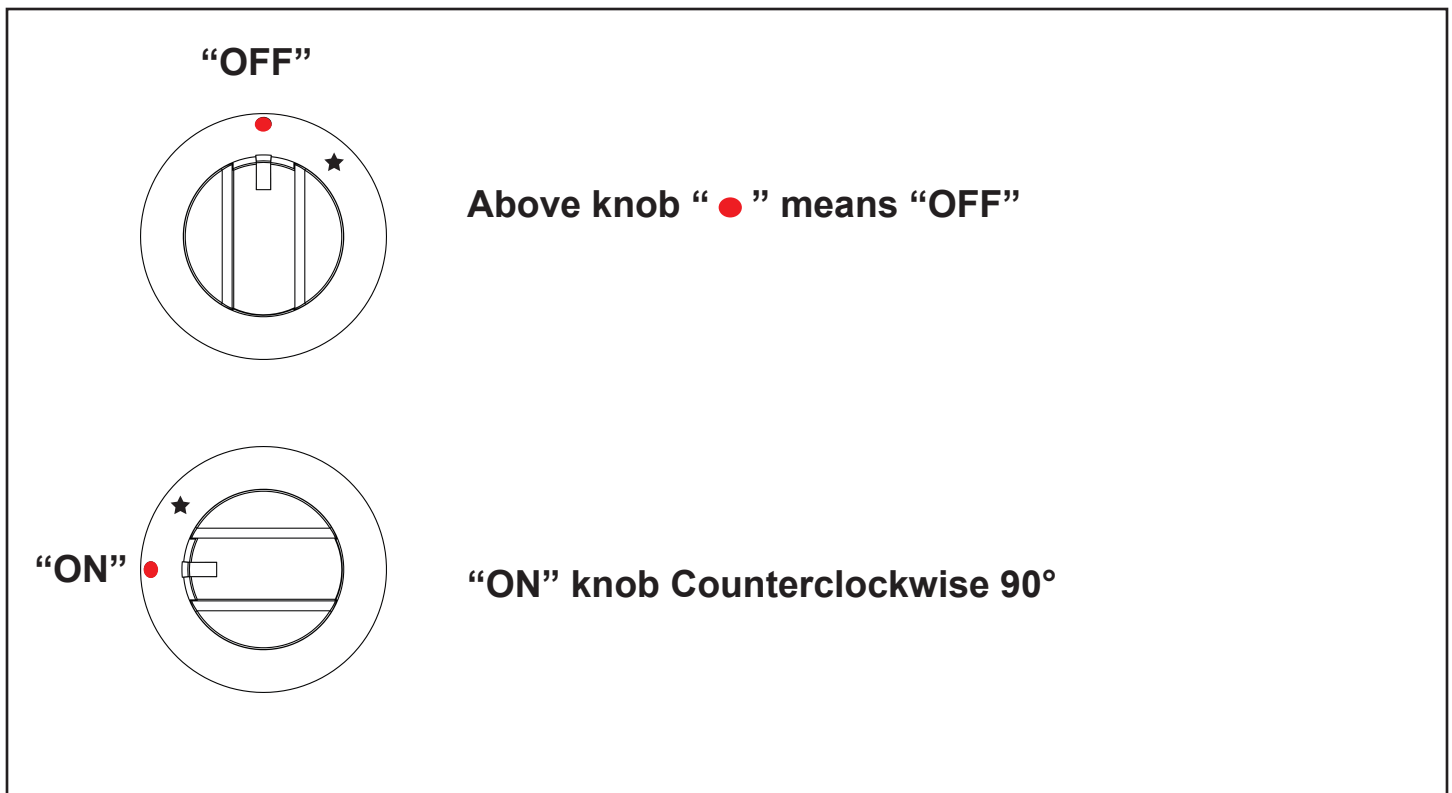

**STANDARD OVEN LIGHTING AND SHUTDOWN INSTRUCTIONS NOTE:  
Light open top/griddle pilots before lighting oven pilot.**

1. Turn thermostat to the "OFF" POSITION.
2. Remove the lower panel.
3. Depress down the knob and rotate to spark star anti-clockwise, Keep pressing knob at the same time, ignite the pilot flame with fire gun via the ignition hole.
4. After the pilot flame is ignited,press the knob for more than 20 seconds to heat up the thermocouple.

If the ignition is out when you loosen the knob,repeat this operation.

5. Keep rotating the temperature control knob anticlockwise to ignite the main burner of the oven.
6. Select appropriate temperature according to food requirement. The oven temperature can be controlled between 250°F and 500°F.

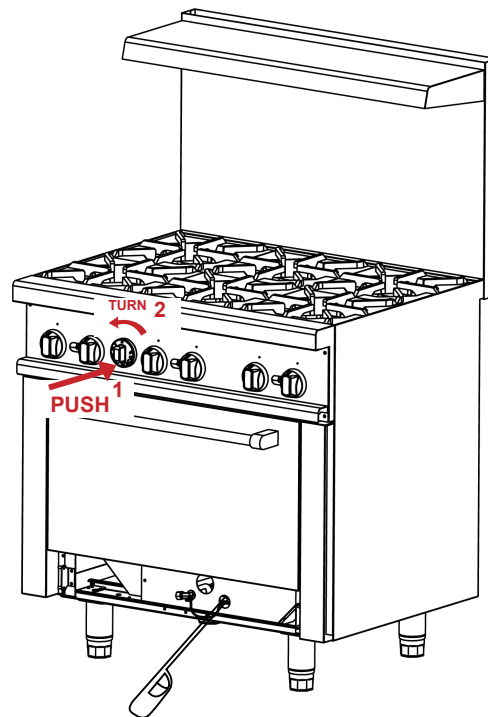
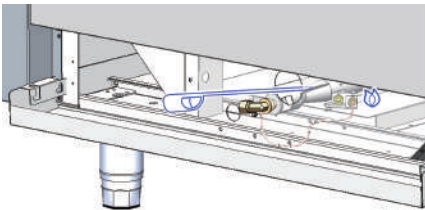

**Nightly Shutdown**

1. Turn oven thermostat OFF.

**Complete Shutdown**

1. Turn oven thermostat OFF.
2. Turn main gas supply OFF.

**RACK ARRANGEMENT -STANDARD OVEN**

The standard oven has three rack positions and is supplied with one two oven racks. Additional racks may be obtained through a vender parts depot.

### **INSERTING AND REMOVING RACK**

The oven rack has a stop to keep the rack from being pulled all the way out when unloading product. To install rack, place rack alongside of top of side liner runners and slide rack completely to the rear of the oven compartment until rack drops into place

To remove rack, reverse the procedure above by raising rear of oven rack stop above runner and pulling rack forward.

### **PREHEATING**

**Standard Oven** Turn thermostat control to the desired cooking temperature and preheat oven for 25 minutes. To save on gas consumption, do not operate oven at maximum heat when it is not necessary. Turn thermostat down to 250°F (121°C) or OFF when oven is not in use or during idle cooking periods.

### **Griddle (optional models)**

Turn the three manual gas valve knobs to full ON. After preheating for 5 minutes, turn valves down until desired flame or heating level is achieved. Position the removable broiler grid into one of the two slide positions, depending on which will achieve the proper product results.

### **CLEANING**

Do not use scouring powder or abrasives anywhere on this range  
Clean only using a soft cloth and mild detergent solution.

### **MAINTENANCE**

**WARNING:** THE RANGE AND ITS PARTS ARE HOT. BE VERY CAREFUL WHEN OPERATING, CLEANING OR SERVICING THE RANGE.

### **VENT**

When cool, the vent should be checked every six months for obstructions.

### **SERVICE AND PARTS INFORMATION**

To obtain repairs, service and parts information concerning this model, contact supplier.  
When calling for service, the following information must be available: model number, serial number, manufacture date (MD) and voltage (optional models).

# TROUBLESHOOTING GUIDE

## STANDARD OVEN RESTAURANT RANGE OVEN

PROBLEM	CAUSES
1. Too much bottom heat 1a. Too low temperature 1b. Side burning 1c. Too much top heat	a) Insufficient ventilation b) Improper fluing c) Improper thermostat bypass setting d) Thermostat out of calibration e) Fluctuating gas pressure
2. Uneven bake side to side	a) Not level side to side b) Oven burner, bottom or baffles improperly installed c) Warped pans
3. Uneven bake front to rear	a) Overactive flue b) Not level front to back; check casters and legs c) Door not closing properly
4. Dried out products	a) Too low temperature (overcooking) b) Too long baking time c) Thermostat calibration
5. Pilot outage	a) Pilot flame too low b) Restriction in pilot orifice c) Problem with shutoff valve d) Possible fluing problems e) Low pressure f) Improper gas line sizing g) Burner box cover not properly installed h) Oven cavity requires resealing

## TOP BURNER OPERATION

1. Improper burner combustion Excessive valve handle temperatures Sticking top burner valves	a) Improper ventilation b) Poor door fit c) Oven door left open d) improper use of excessively large pans or pots
2. Poor ignition	a) Insufficient input b) Poor air-gas adjustment c) Restriction in pilot orifice d) Restriction in main burner ignition port

# Conversion Kit Instructions for the Gas restaurant ranges

## WARNING

This conversion kit shall be installed by a qualified service agency in accordance with the manufacturer's instructions and all applicable codes and requirements of the authority having jurisdiction. If the information in these instructions is not followed exactly, a fire, an explosion or production of carbon monoxide may result causing property damage, personal injury or loss of life. The qualified service agency is responsible for the proper installation of this kit. The Installation is not proper and complete until the operation of the converted appliance is checked as specified in the manufacturer's instructions supplied with the kit."

## Range Conversion Kit Instructions



### WARNING

Do not attempt gas conversion by yourself. Gas conversion of your unit is to be made by a certified/licensed technician.

### CONVERSION

Instructions are for conversion from Natural Gas to Propane (L.P.) on 24" & 36" & 60" models. The conversion should be done before connecting the unit to the gas supply. Units are shipped from the factory equipped for use on natural gas. Parts necessary for L.P. (liquid propane) are provided with the unit. Please refer to page 5 the orifice size list when you do gas conversion..

**Turn off the main gas supply before doing any maintenance.**

1. Remove the top grate

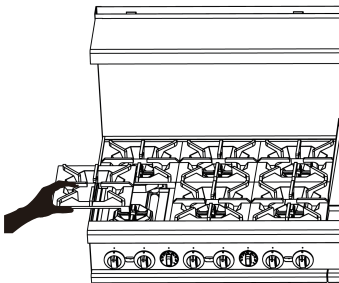

2. Raise the top burner and pull, Exposed the orifice.

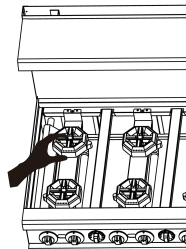

3. Loose orifice by hex wrench.

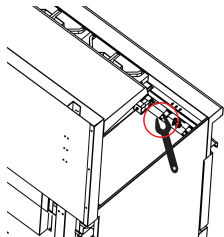

4. Replace orifice and locked.

Note: orifice number markd on orifice

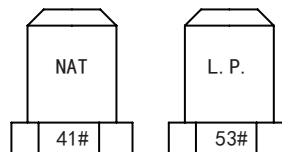

## Conversion Kit Instructions

5. Put back top burner, Caution: air shutter must be toward orifice.

6. Put back top grate.

7. Remove the oven bottom drop pan, and radiator plate.

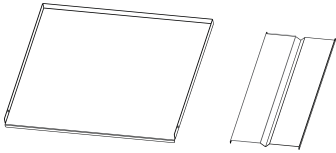

8. Loose the screw of oven burner back, raise burner and pull backward.

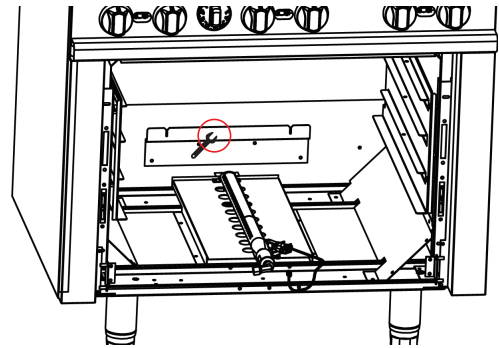

9. Loose orifice by hex wrench

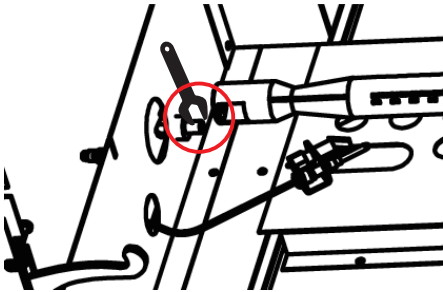

10. Replace orifice and locked.  
Note: drill size marked on orifice

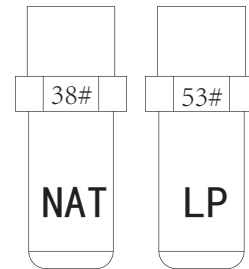

11. Use a wrench to loosen the screw of the pilot bracket

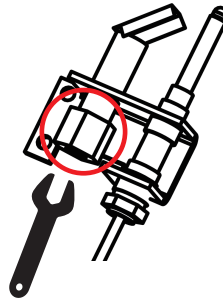
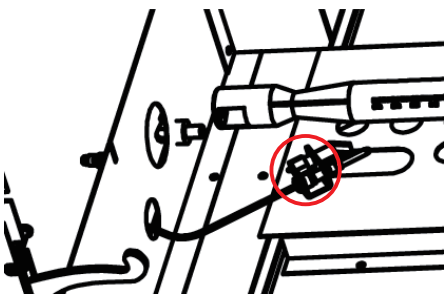

12. Adjust flame size

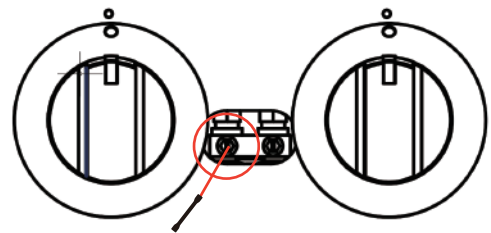

## Conversion Kit Instructions

13. Replace pilot orifice and locked.  
Note: drill size marked on orifice body

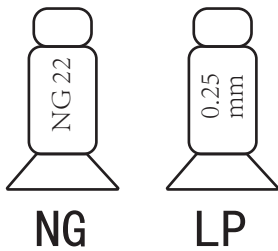

14. Put back oven burner,  
Caution: air shutter must be toward orifice,  
lock burner fix screw

15. Put back radiator plate and drop pan.

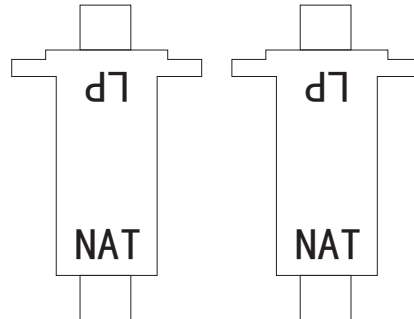

16. Regulator convert

Before installing the included convertible regulator, unscrew the octagon cap. You can read (NAT) on the plastic insert attached to the head of the cap; flip it over and snap back in place.

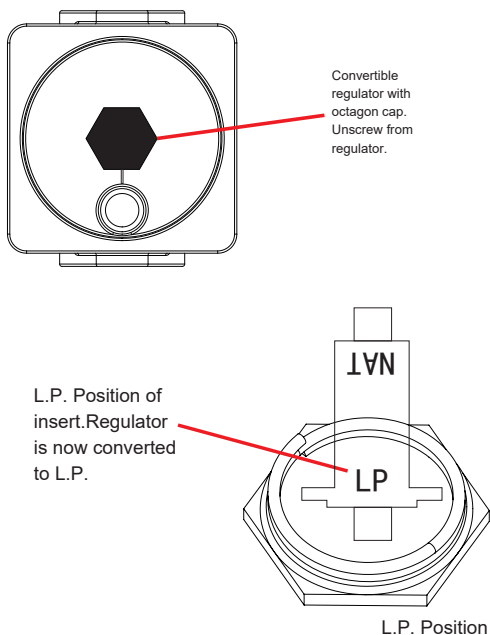

Pictured is the plastic insert. Pull off insert from octagon cap and reverse the plastic insert position so that the L.P. position is attached to the octagon cap head.

17. Continue with installation.

18. Completed gas conversion.

19. Check all joints in the gas supply line for leaks.  
use soap and water solution. do not use an open flame.

## Warranty

---

### What this limited warranty covers:

- This limited warranty provided by Forno Appliances applies exclusively to the original Forno appliance (“Product”) sold to the original purchaser (“Purchaser”) by an authorized Forno dealer, distributor, or retailer, and installed in the United States or Canada. The Product must remain within the country of original purchase.
- This warranty is valid for a period of one (1) year from the date of original retail purchase and covers parts and labor.
- This warranty is strictly limited to commercial use. Any residential use of the Product will void this warranty.
- Forno Appliances will repair or replace, at its discretion, any component or part that proves to be defective due to manufacturing defects in materials or workmanship under normal commercial use during the warranty period. Repair or replacement will be performed by a Forno Authorized Service provider during normal working hours.
- This warranty does not cover installation, misuse, abuse, improper maintenance, or normal wear and tear. The Purchaser is responsible for ensuring the Product is reasonably accessible for service.
- Warranty coverage is non-transferable. In the event of replacement of parts or the entire Product, the replacement will assume the remaining warranty period from the original purchase date. The warranty period will not be extended.

### Important

Retain proof of original purchase to establish the warranty period. Forno’s liability on any claim of any kind, with respect to the goods and/or services provided, shall in no event exceed the value of the product, service, or part thereof which has given rise to the claim.

### 30-Day Cosmetic Warranty

The Purchaser must inspect the Product at the time of delivery. Forno warrants that the Product is free from manufacturing-related cosmetic defects in materials and workmanship for a period of thirty (30) days from the date of original retail purchase.

### This coverage includes:

- Paint blemishes
- Chips
- Visible finish defects

### Cosmetic warranty does NOT cover:

- Damage resulting from improper transportation, handling, or installation (including dents, warping, deformation, or damaged components, cracked or damaged glass components)
- Minor color variations in painted or enameled parts
- Differences caused by lighting conditions, installation location, or similar factors
- Stains, corrosion, or discoloration caused by external substances or environmental conditions
- Labor costs
- Display models, floor models, B-stock, open-box, “as-is” products, or demo units

### What Exclusion: What is not covered

- Installation services at the time of purchase or during product replacement.
- Use of the Product in any residential or non-commercial application
- Use of the Product for purposes other than its intended use
- Service or repairs performed by anyone other than a Forno Authorized Service provider
- Damage or repair services required to correct work performed by unauthorized parties or the use of unauthorized parts.
- Installation not in accordance with local/state/county fire codes, electrical codes, gas codes, plumbing codes, building codes, laws or regulations.
- Defects or damage due to improper storage of the Product.
- Defects, damage or missing parts on products sold out of the original factory packaging or from displays.
- Service calls or repairs to correct an incorrect installation of the Product and/or related accessories.
- Replacement of parts/service calls to connect, convert or otherwise repair the electrical wiring and/or gas line in order to properly use the product.
- Replacement of parts/service calls to provide instructions and information on the use of the Product.
- Replacement of parts or service calls to correct issues arising from use of the Product in a manner inconsistent with normal and customary commercial use.
- Replacement of parts/service calls due to wear and tear of components such as seals, knobs, pan supports, shelving, cutlery baskets, buttons, touch displays, scratched or broken ceramic-glass tops.
- Replacement of parts/service calls for lack of/improper maintenance, including but not limited to: build up of residues, stains, scratches, discoloration, corrosion.
- Defects and damages arising from accidents, alteration, misuse, abuse or improper installation.
- Defects and damages arising from Product transport, logistics and handling. Inspection of the product must be made at time of delivery. Following receipt and inspection, the selling dealer/delivery company must be notified of any issues arising from handling, transport and logistics.
- Defects or damage resulting from external forces beyond the control of Forno Appliances, including but not limited to wind, rain, sand, fire, flooding, mudslides, freezing temperatures, excessive moisture or prolonged exposure to humidity, power surges, lightning, structural failures surrounding the appliance, or other natural phenomena.
- Products whose serial number has been altered/damaged/tampered with. In no case shall Forno be held liable or responsible for damage to surrounding property, including furniture, cabinetry, flooring, panels, and other structures surrounding the Product. Forno is neither liable nor responsible for the Product if it is located in a remote area or an area where certified trained technicians are not reasonably available. Purchaser must bear any transportation and delivery costs of the Product to the nearest Authorized Service Center or the additional travel expenses of a certified trained technician.

## **Warranty (continued)**

---

### **DISCLAIMER OF WARRANTIES AND LIMITATION OF LIABILITY**

There are no warranties, either express or implied, other than those listed and described above, including but not limited to any implied warranties of merchantability or fitness for a particular purpose, that shall apply after the express warranty period stated above.

No other express warranty or guarantee given by any person, firm, or corporation with respect to this Product shall be binding on Forno.

Forno shall not be liable for any loss of revenue or profits, failure to realize expected savings or other benefits, time away from work, loss of food or beverages, travel or lodging expenses, costs to rent or purchase replacement appliances, or any remodeling or construction expenses.

Forno shall also not be liable for any indirect, incidental, special, or consequential damages arising from the use, misuse, or inability to use this Product, regardless of the legal theory on which the claim is based, and even if Forno has been advised of the possibility of such damages.

In no event shall Forno's total liability exceed the purchase price of the Product giving rise to the claim.

The Purchaser assumes all risk and liability for any loss, damage, or injury to persons or property resulting from the use, misuse, or inability to use the Product, except where such damage is directly caused by the negligence of Forno.

This limited warranty is non-transferable, applies only to the original Purchaser, and constitutes the Purchaser's exclusive remedy.



FOR  
**FAST SUPPORT**  
EMAIL AT [INFO@FORNO.CA](mailto:INFO@FORNO.CA) 

Customer Support: Call 1-866-231-8893 or email: [info@forno.ca](mailto:info@forno.ca)