

# Iron Swing

## Assembly Instructions

### Assembly Tips:

The weight and length of the parts makes this a two person assembly.

To properly align metal parts, all hardware should first be fastened to about one rotation from being snug. **DO NOT** "tighten as you go."

Do not overtighten. A small socket wrench is adequate. A power drill/socket is quicker, but also more likely to over-torque and damage the unit. It is also more likely to strip the powder-coat off of the hardware, allowing rust to form.

### Parts List

Tube frame front	2
Tube frame back	2
Frame top	1
Side frame braces	2
Rear cross frame supports	2
Base caps	4
Seat support brackets	2
Chain	2
"S" hook	2
Mounting hardware (above right)	
Hex bolt set (#4)	4
Hex wrench	1
Side brace bolt set (#1)	4
Cross support bolts (#1)	4
Support connect bolt set (#3)	1
Seat bolt set (#2)	8

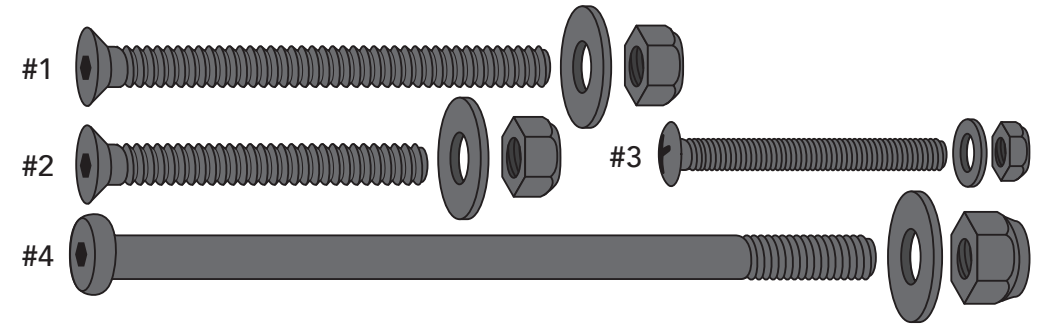

### Frame

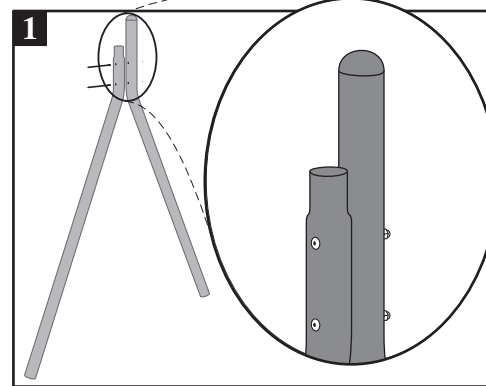

Step 1. Combine front (open top) and rear (capped top) swing supports for both sides of the swing with the long hex head bolt and nut (#4 above). Snug, but do not tighten.

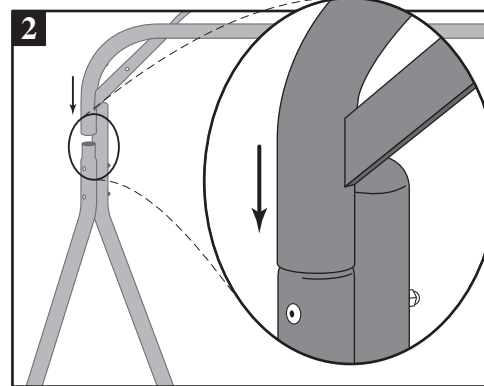

Step 2. Attach top frame section by aligning with side frame as shown, then pulling down until sections fit tightly. Now, tighten the bolts from step 1.

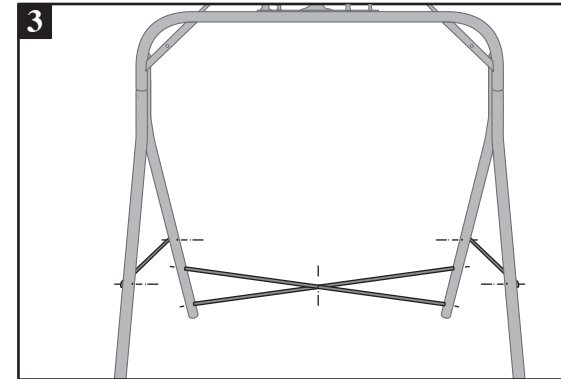

Step 3. Add side braces using short hex head bolts and nuts (#1 above). Add the rear cross supports by threading bolt (#1 above) through frame and into each end. Use bolt and nut (#3 above) to secure the braces together where they cross.

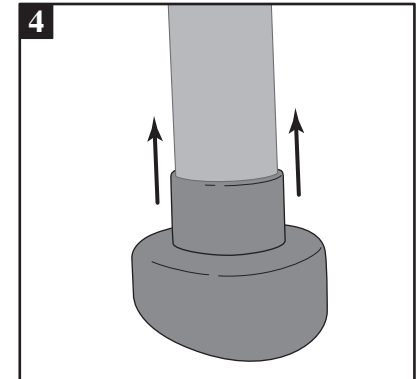

Step 4. Lift each corner of the frame and slide the plastic bases onto the bottom of the frame legs.

### Tools needed:

Medium phillips screwdriver  
Adjustable wrench

### Maintenance Tip:

Although this is a maintenance-free product, there are steps you can take to keep it looking its best. Sun exposure will eventually break down any paint, even 2 layers of powder coat. Less sun exposure equals longer paint life. Partial shade placement, off season storage, etc. helps extend the life of the finish. If the product needs to be in the sun year-round, do so. That's what it was designed for.

### Swing Seat

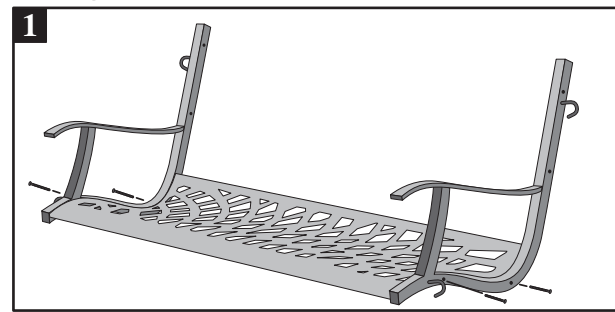

Step 1. Attach seat to the seat frame with the nut/bolt/washer combo (#2 above). Do not tighten.

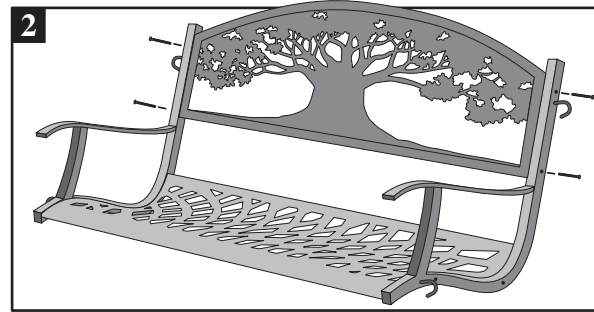

Step 2. Attach the back casting in the same manner as in step 1. Now, tighten All bolts.

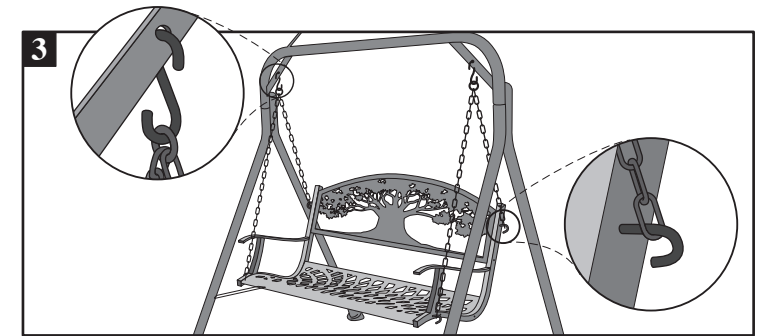

Step 3. Attach "S" hook to top corners of frame. Attach the "O" ring in each chain to one "S" hook. Hang swing from chains using the longest section in the front, and the short section in the back.