

Assembly Instruction

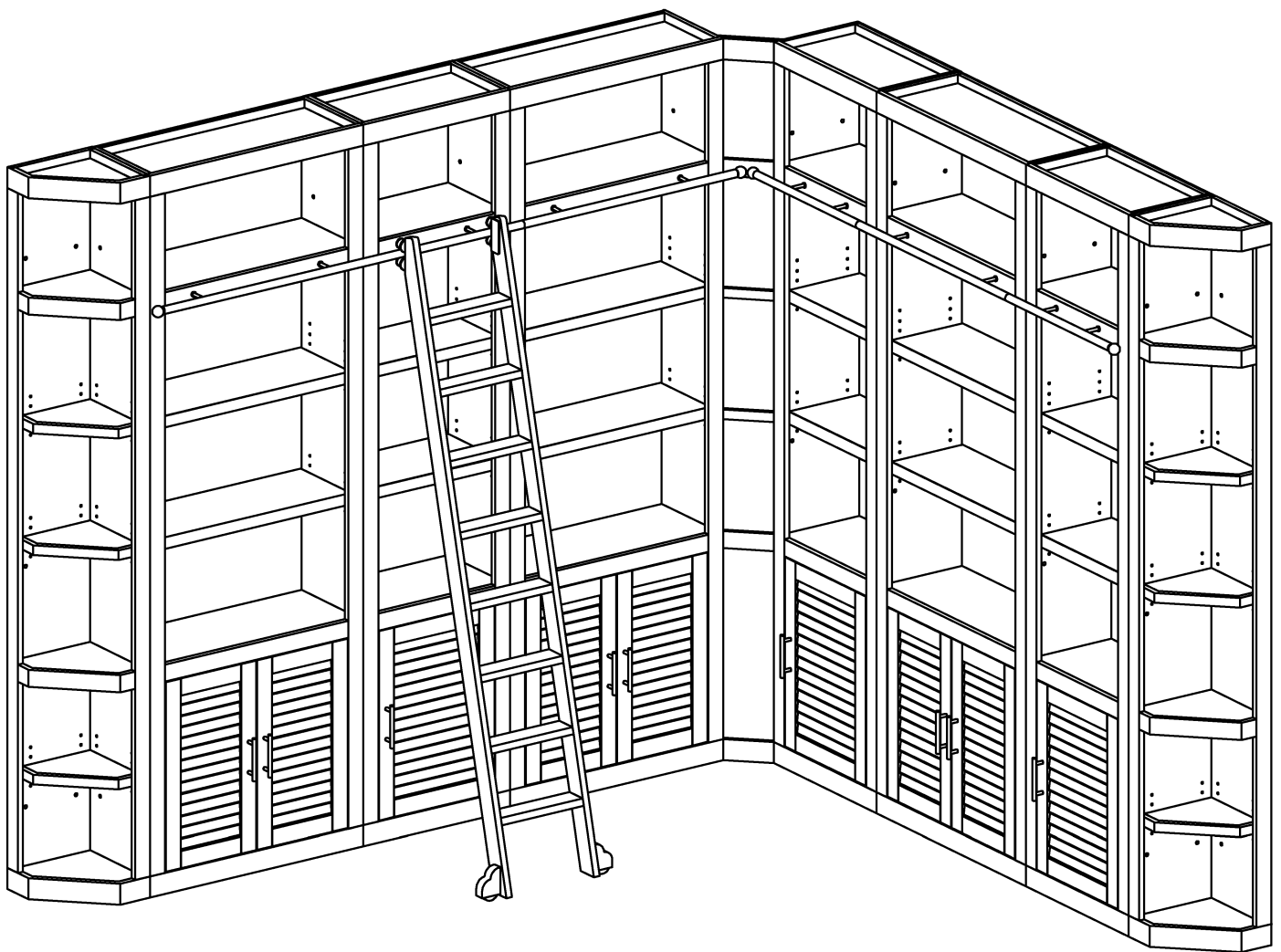







Item NO: CAT#420











Assembly Instruction

Item NO: CAT#420

Hardwares

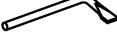
NO	Description	Sketch	Q'TY
A	Wrench		1pc
B	Allen Wrench	4mm 	1pc
C	Allen Wrench	2.5mm 	1pc
D	25mm Bolt		6pcs
E	Screw Cap		6pcs
F	Ladder Rail Finial		1pc
G	Ladder Rail Coupler		1pc
H	Ladder rail		1pc
I	Flat washer white		2pcs

NO	Description	Sketch	Q'TY
J	Hex nut		2pcs
K	Lock washer		2pcs
L	Flat washer White zinc		2pcs
M	Shelf Support		4pcs
N	Screw		4pcs
O	Allen Wrench		1pc
P	Allen Wrench		1pc
	Touch up Pen		1pc

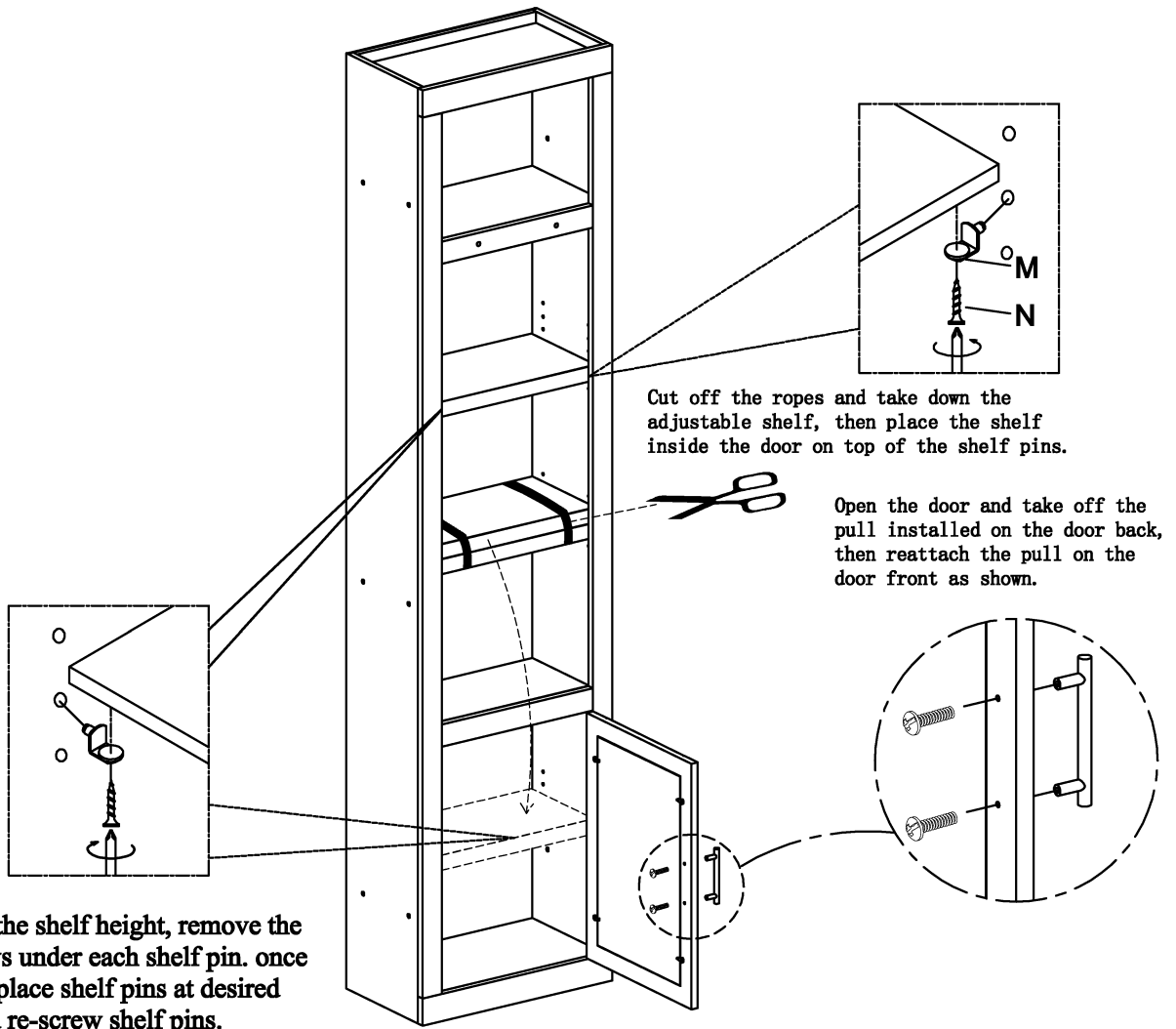

Assembly Instruction

Item NO: CAT#420

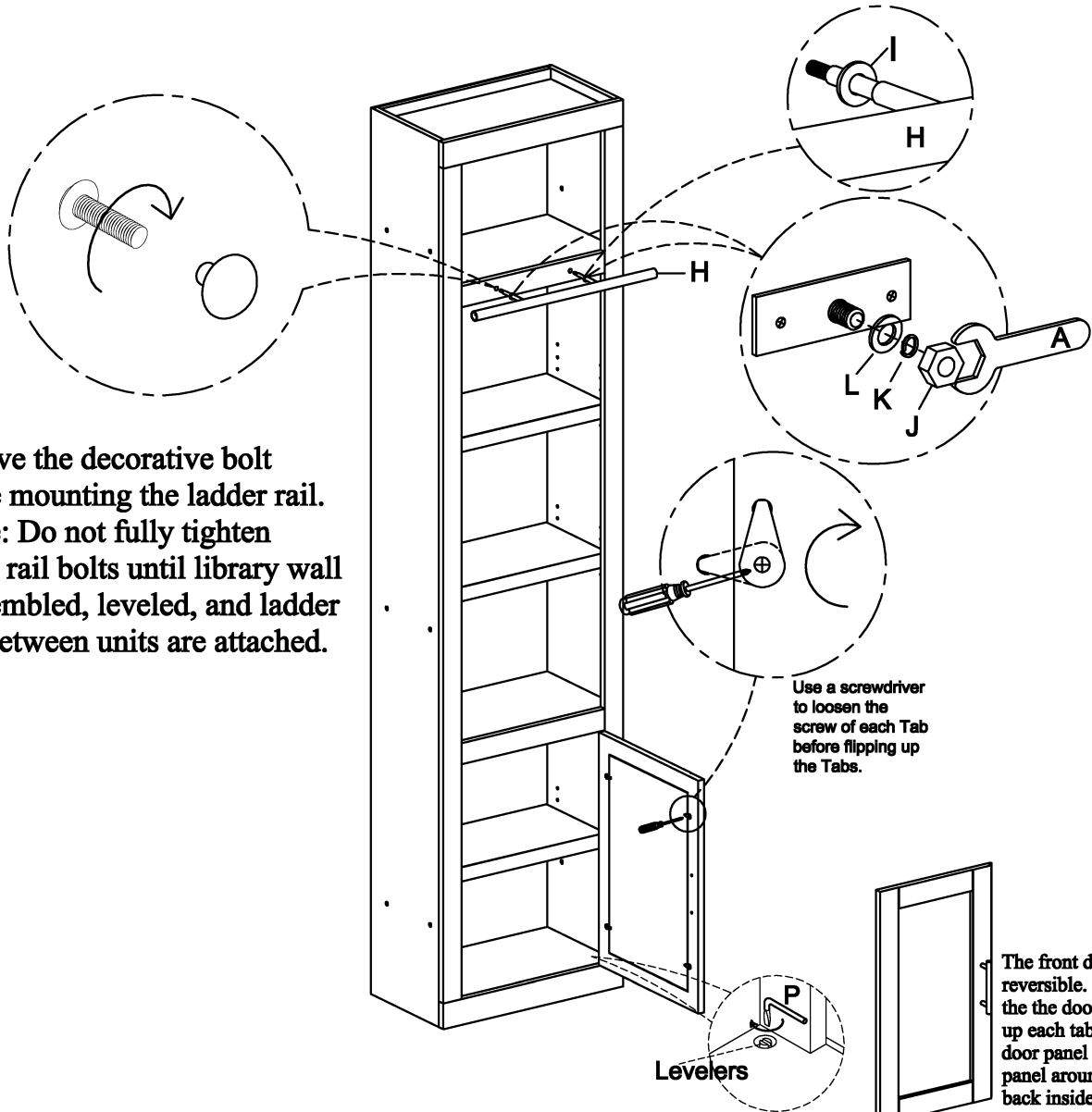

Remove the decorative bolt before mounting the ladder rail. Please: Do not fully tighten ladder rail bolts until library wall is assembled, leveled, and ladder rails between units are attached.

Use a screwdriver to loosen the screw of each Tab before flipping up the Tabs.

Levelers

Inside the bottom panel on the forward RSF side is a cap with the leveler below. To adjust the leveler remove the cap and turn the leveler to adjust the height of the bookcase with Allen Wrench(P).

The front door panel is reversible. To change the the door panel, flip up each tab and push door panel out. Turn the panel around and place back inside the door and flip the tabs down to hold it in place.

Assembly Instruction

Item NO: CAT#420

To reverse the back panel, unscrew the cleat and back panel as shown in the diagram below. Turn the back panel to the desired finish and re-screw.

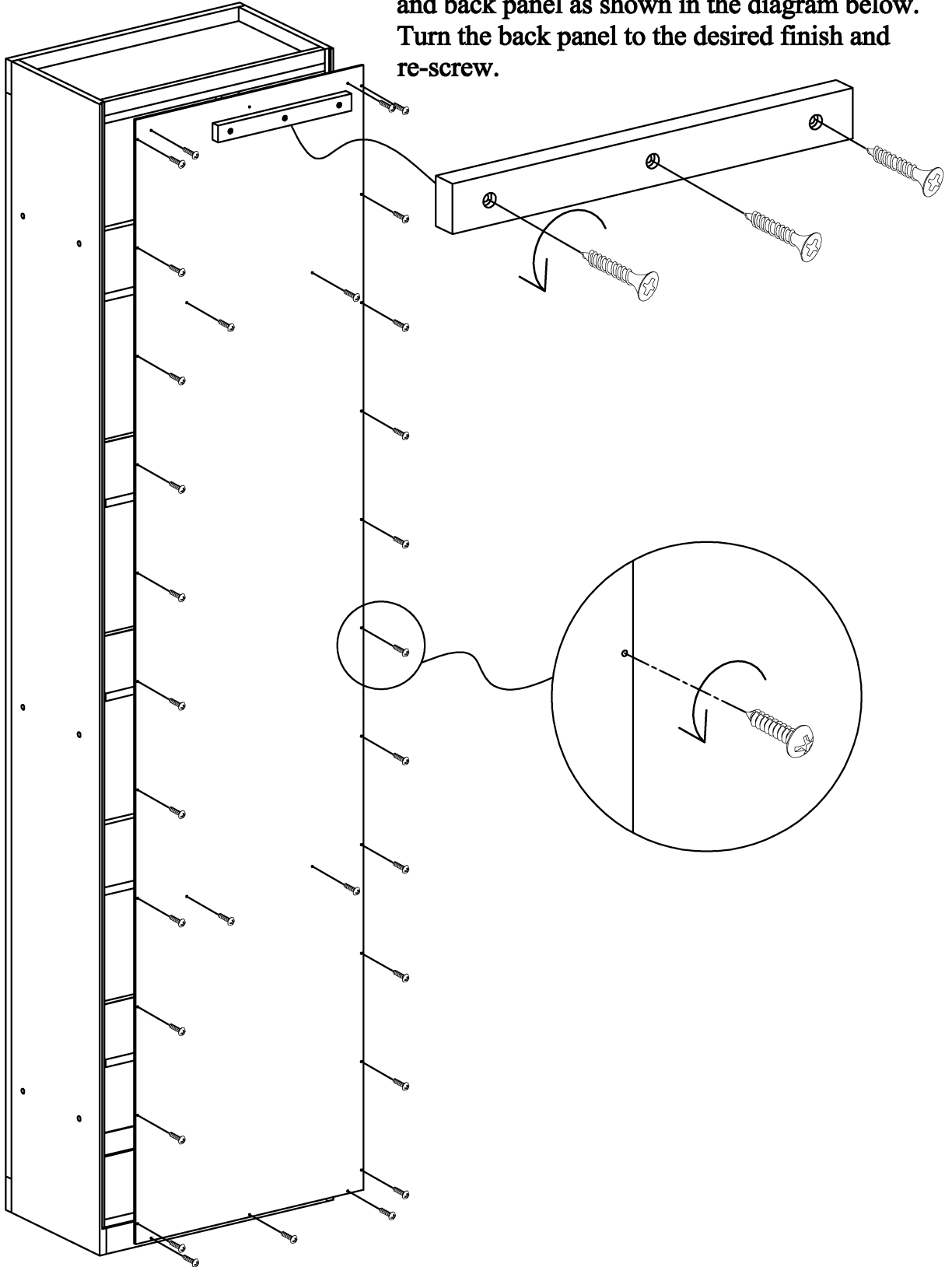

Assembly Instruction

Item NO: CAT#420

If setting up an end piece, use Allen Wrench(C) to loosen retaining screw found on each rail end, secure Ladder Rail Finial (F) to ladder rail end to complete finished look.

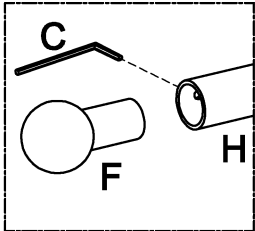

To connect ladder rails, loosen retaining screw found on each rail end, insert ladder rail coupler (G) about 1" on one side, and tighten. Align cabinets and push together, aligning ladder rails in the process. Tighten opposite retaining screw to secure ladder rail coupler.

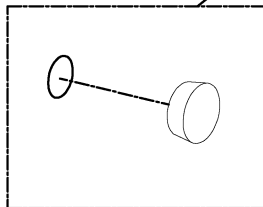
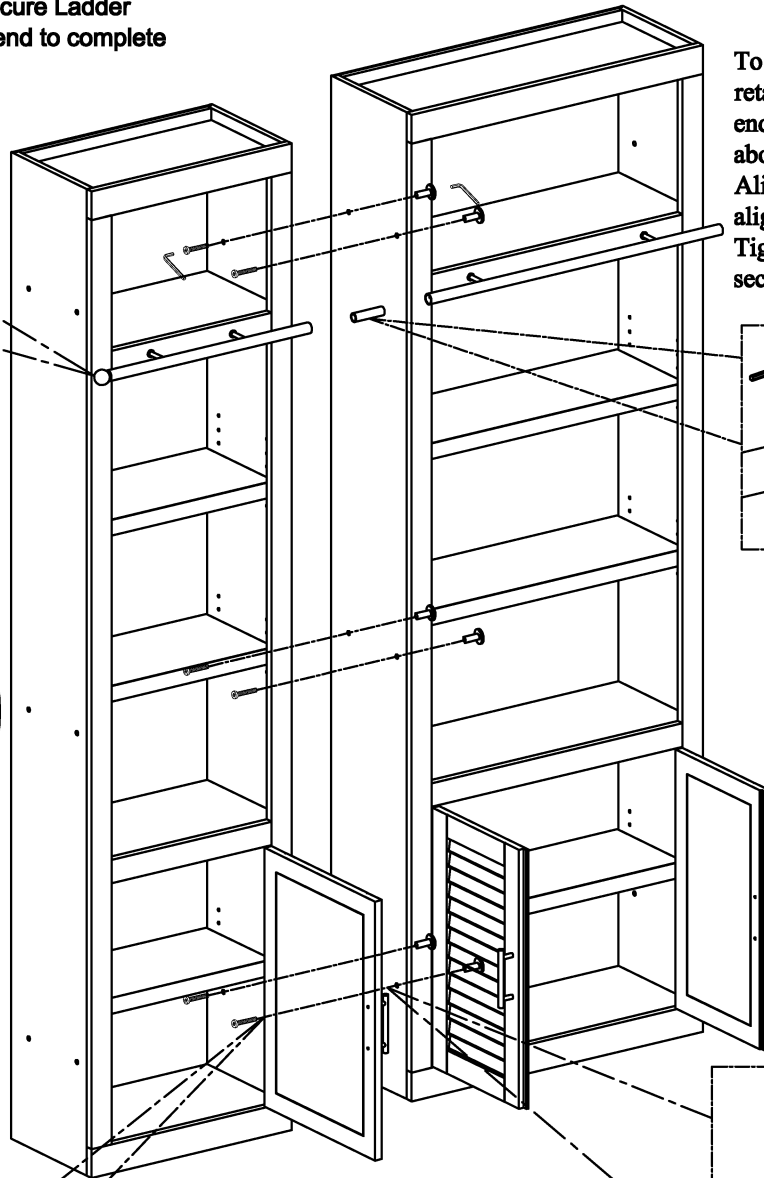
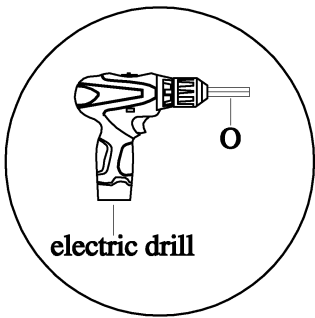
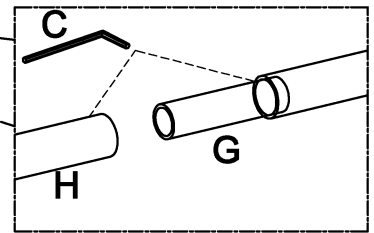

Remove the wood plugs before connecting the cabinets together.

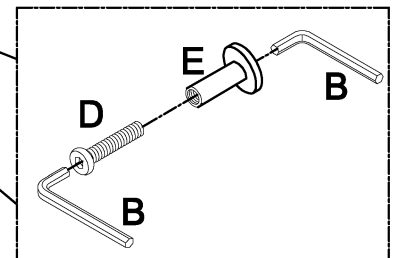

Align and connect cabinets with Connector Bolt (D) and Connector Cap (E).

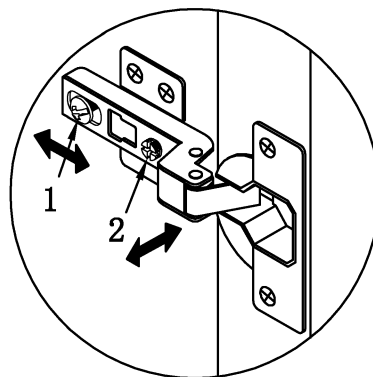

The library self closing hinges can be adjusted with the above diagram screws

Assembly Instruction



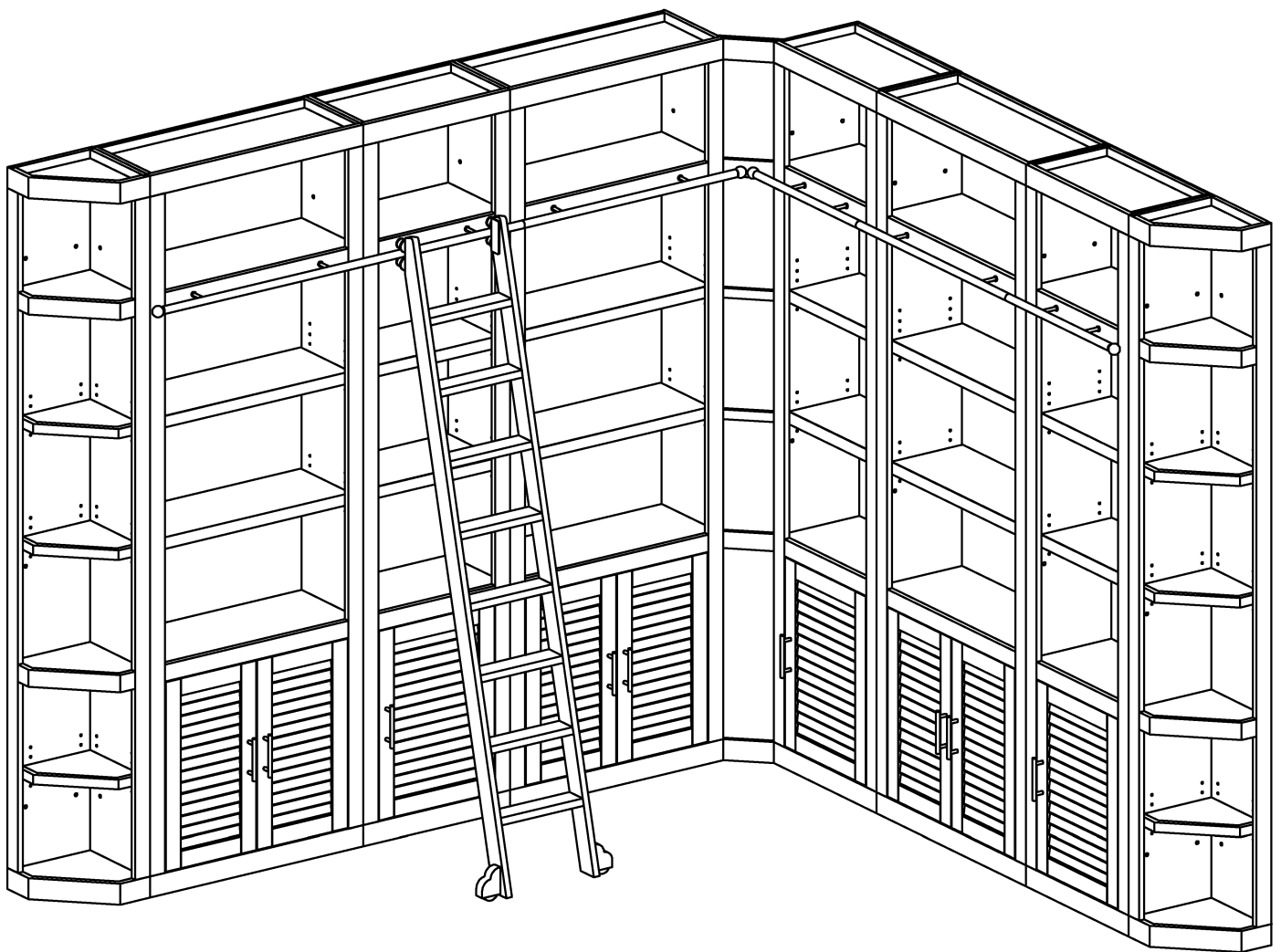





Item NO: CAT#430









Assembly Instruction

Item NO: CAT#430

Hardwares

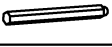
NO	Description	Sketch	Q'TY
A	Wrench		1pc
B	Allen Wrench	4mm 	1pc
C	Allen Wrench	2.5mm 	1pc
D	25mm Bolt		6pcs
E	Screw Cap		6pcs
F	Ladder Rail Finial		1pc
G	Ladder Rail Coupler		1pc
H	Ladder rail		1pc
I	Flat washer white		2pcs

NO	Description	Sketch	Q'TY
J	Hex nut		2pcs
K	Lock washer		2pcs
L	Flat washer White zinc		2pcs
M	Shelf Support		4pcs
N	Screw		4pcs
O	Allen Wrench		1pc
P	Allen Wrench		1pc
	Touch up Pen		1pc

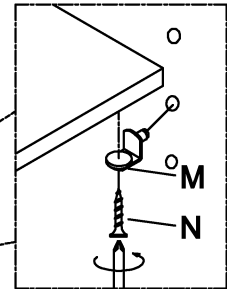
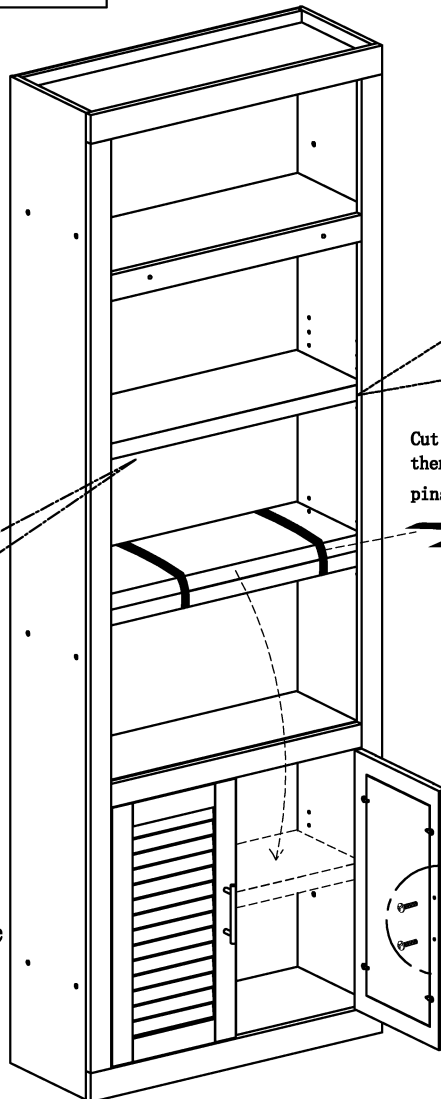

Cut off the ropes and take down the adjustable shelf, then place the shelf inside the door on top of the shelf pins.



Open the doors and take off the pulls installed on the back of doors, then reattach the pulls on the front side of doors as shown.

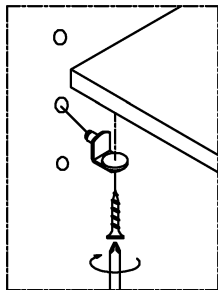
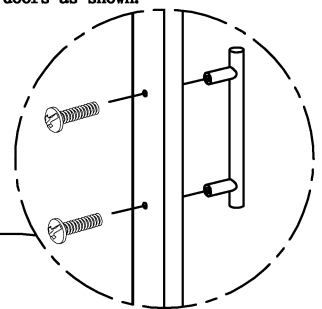

To adjust the shelf height, remove the four screws under each shelf pin. once removed, place shelf pins at desired height and re-screw shelf pins.

Assembly Instruction

Item NO: CAT#430

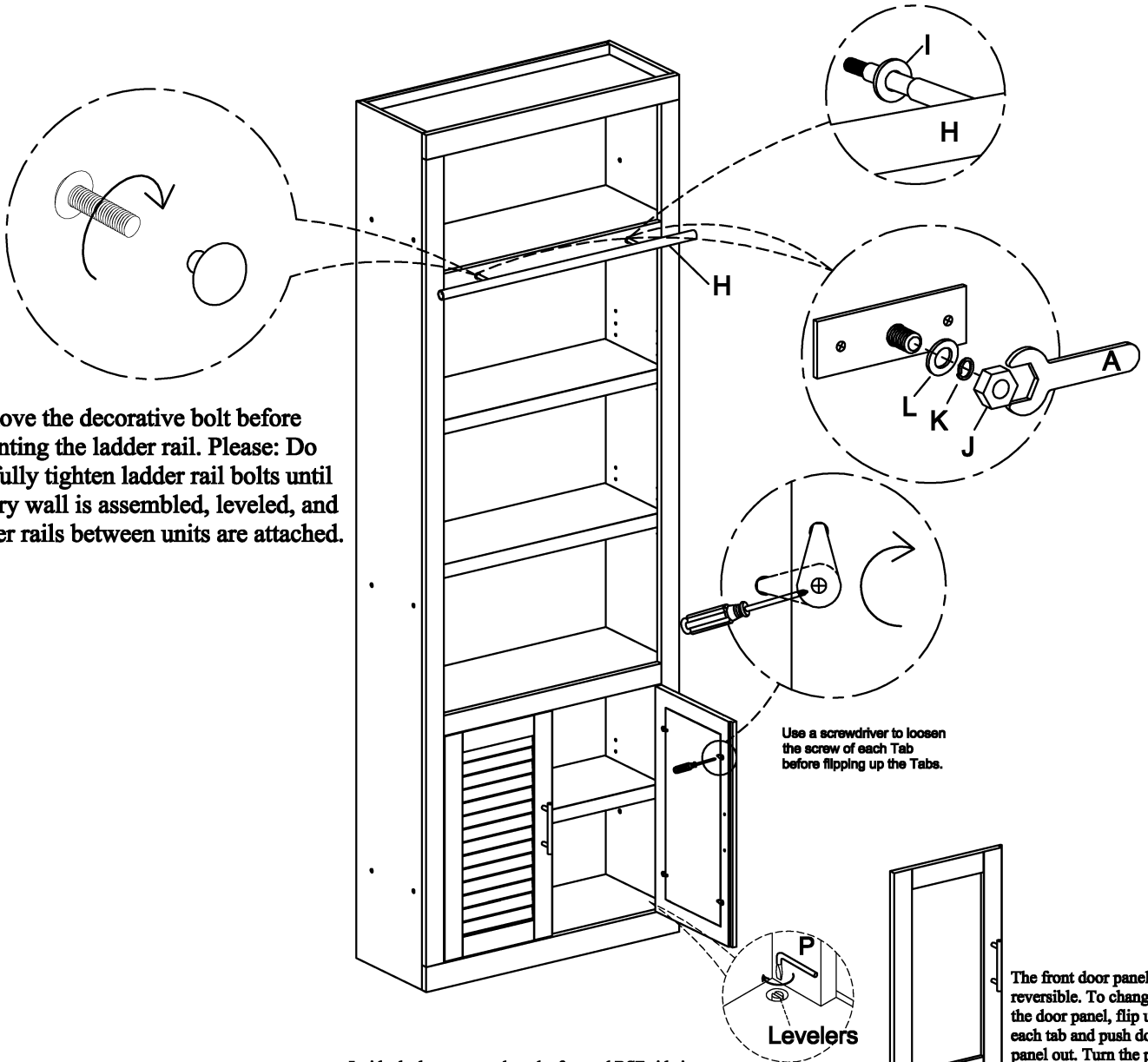

Remove the decorative bolt before mounting the ladder rail. Please: Do not fully tighten ladder rail bolts until library wall is assembled, leveled, and ladder rails between units are attached.

Use a screwdriver to loosen the screw of each Tab before flipping up the Tabs.

Inside the bottom panel on the forward RSF side is a cap with the leveler below. To adjust the leveler remove the cap and turn the leveler to adjust the height of the bookcase with Allen Wrench(P).

The front door panel is reversible. To change the door panel, flip up each tab and push door panel out. Turn the panel around and place back inside the door and flip the tabs down to hold it in place.

Assembly Instruction

Item NO: CAT#430

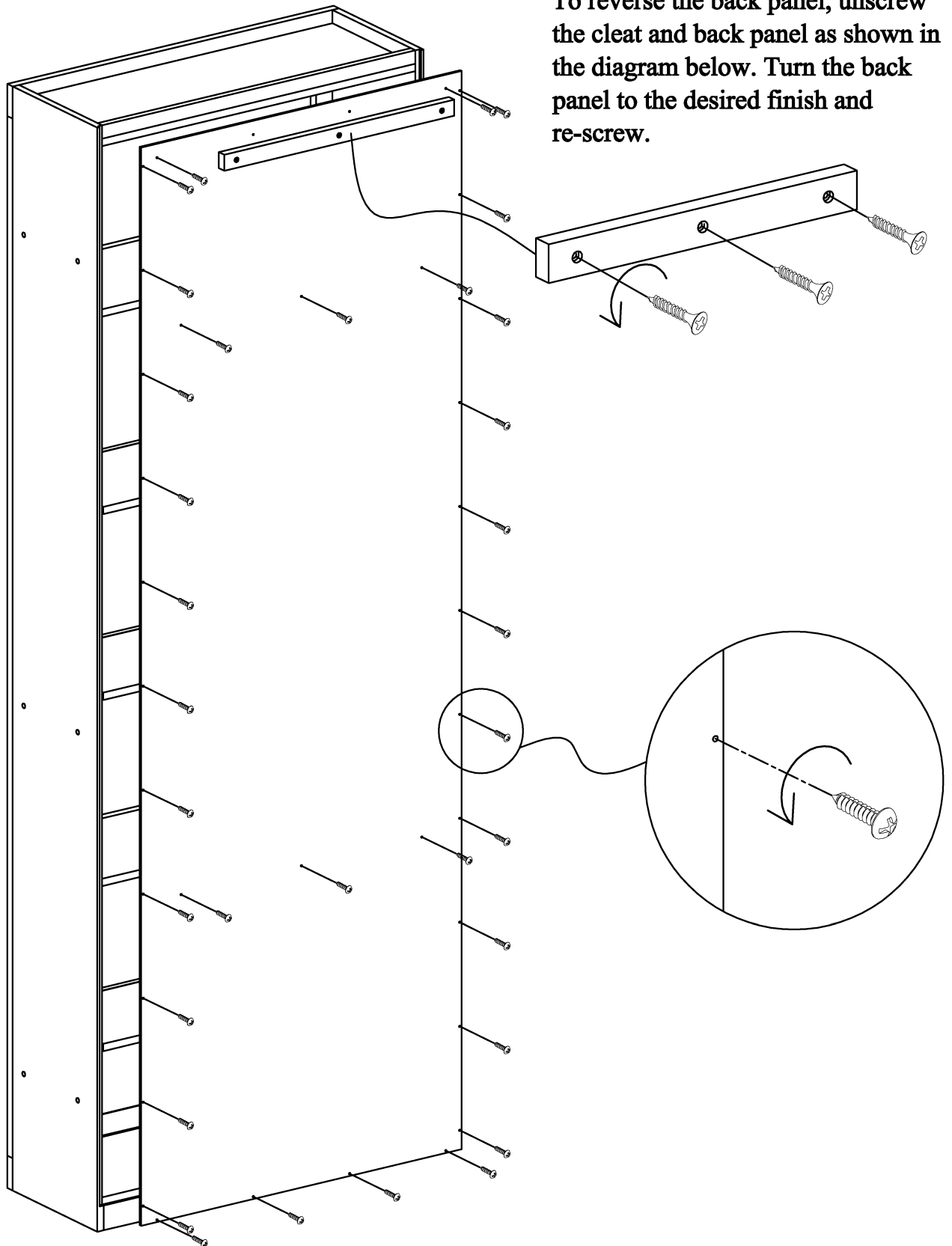

To reverse the back panel, unscrew the cleat and back panel as shown in the diagram below. Turn the back panel to the desired finish and re-screw.

Assembly Instruction

Item NO: CAT#430

If setting up an end piece, use Allen Wrench(C) to loosen retaining screw found on each rail end, secure Ladder Rail Finial (F) to ladder rail end to complete finished look.

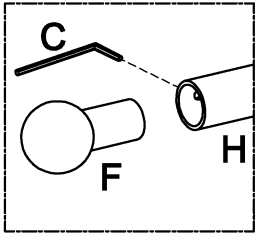

To connect ladder rails, loosen retaining screw found on each rail end, insert ladder rail coupler (G) about 1" on one side, and tighten. Align cabinets and push together, aligning ladder rails in the process. Tighten opposite retaining screw to secure ladder rail coupler.

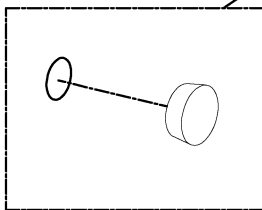
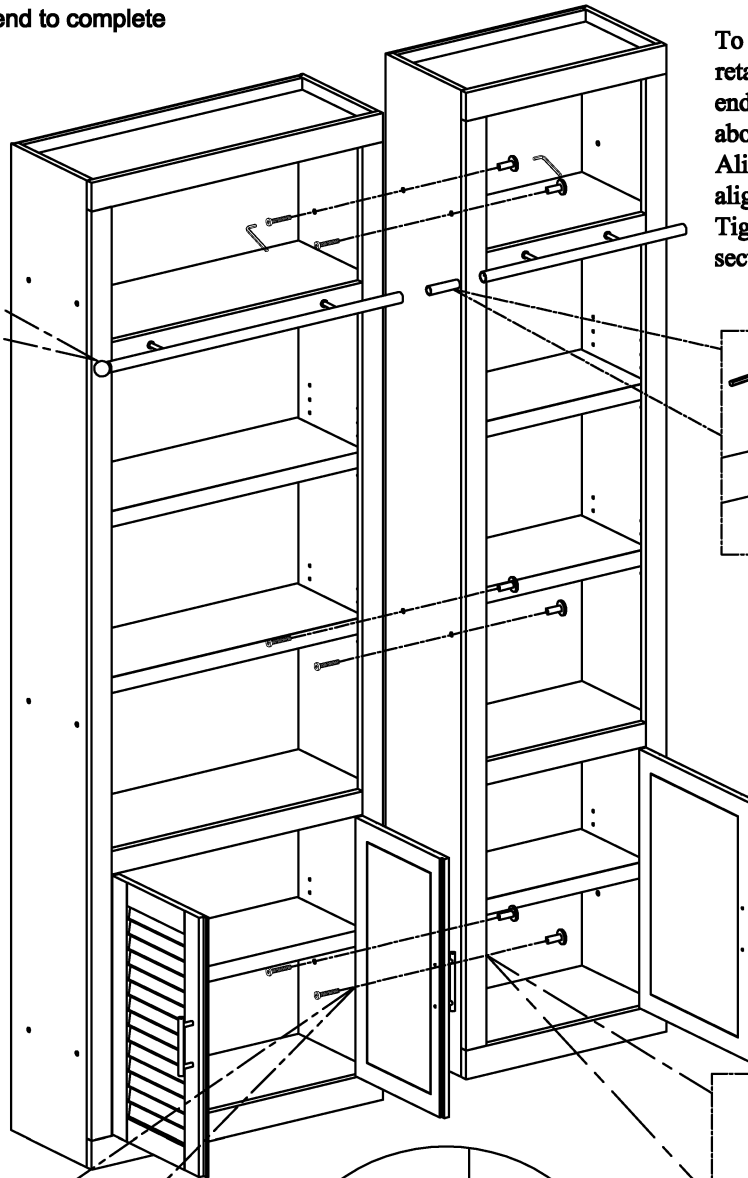
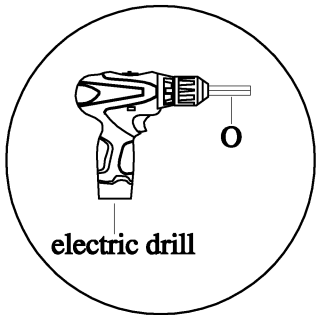
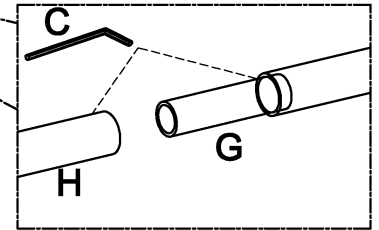

Remove the wood plugs before connecting the cabinets together.

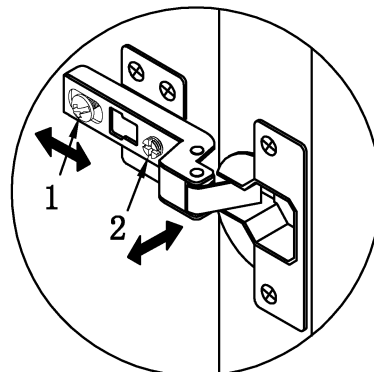

The library self closing hinges can be adjusted with the above diagram screws.

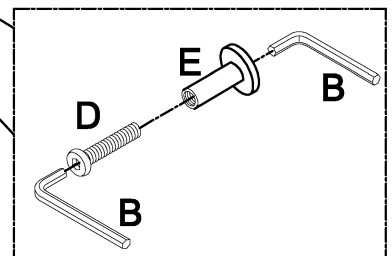

Align and connect cabinets with Connector Bolt (D) and Connector Cap (E).

Assembly Instruction

Item NO: CAT#450



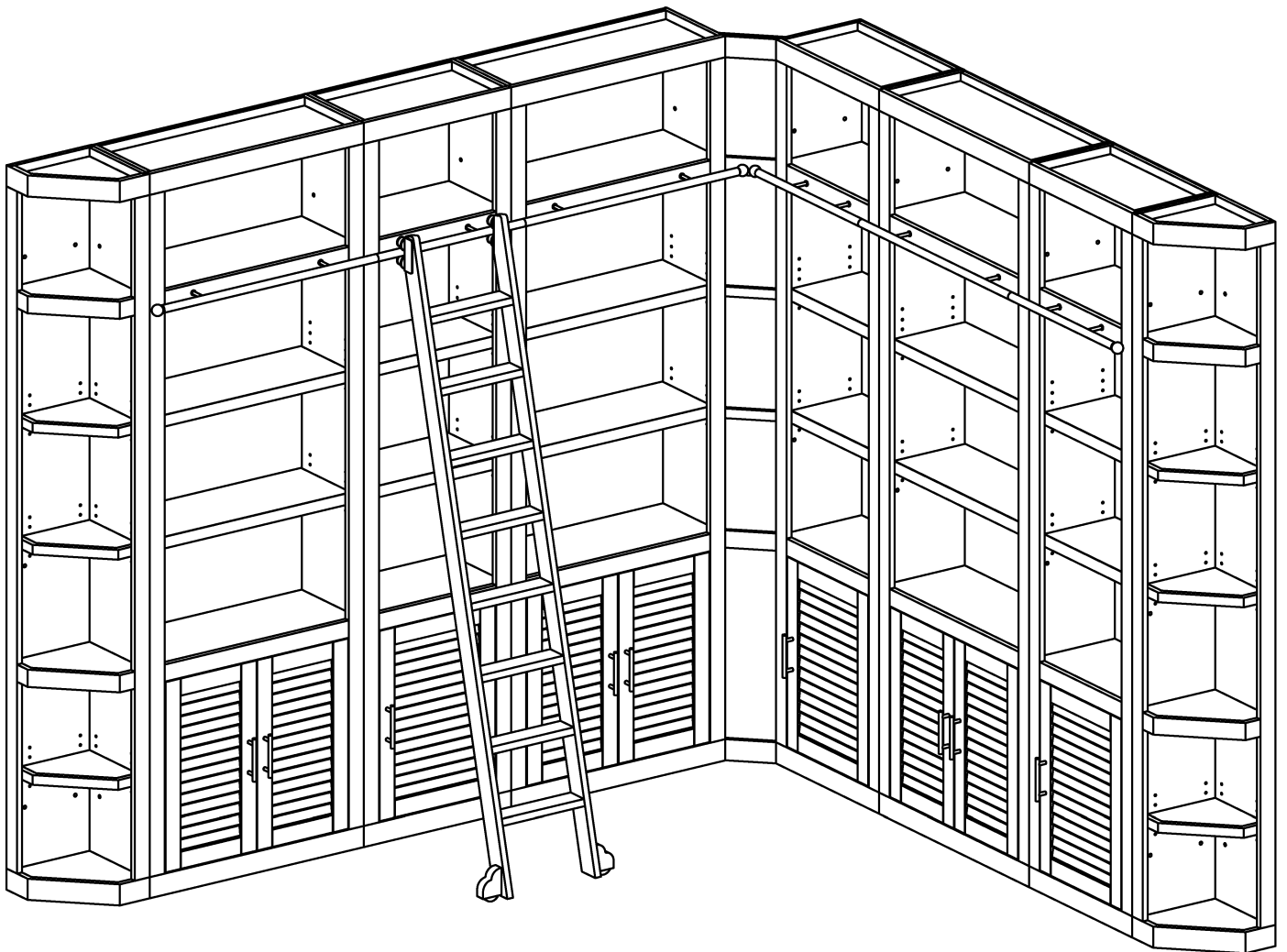

1/2



Assembly Instruction

Item NO: CAT#450

2/2

NO	Description	Sketch	Q'TY
A	Allen Wrench	4mm 	1pc
B	25mm Bolt		6pcs
C	Screw Cap		6pcs
O	Allen Wrench		1pc
	Touch up Pen		1pc

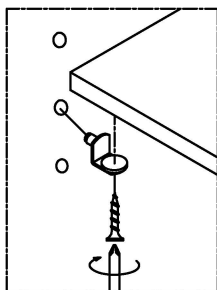
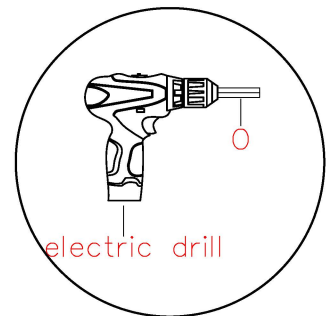
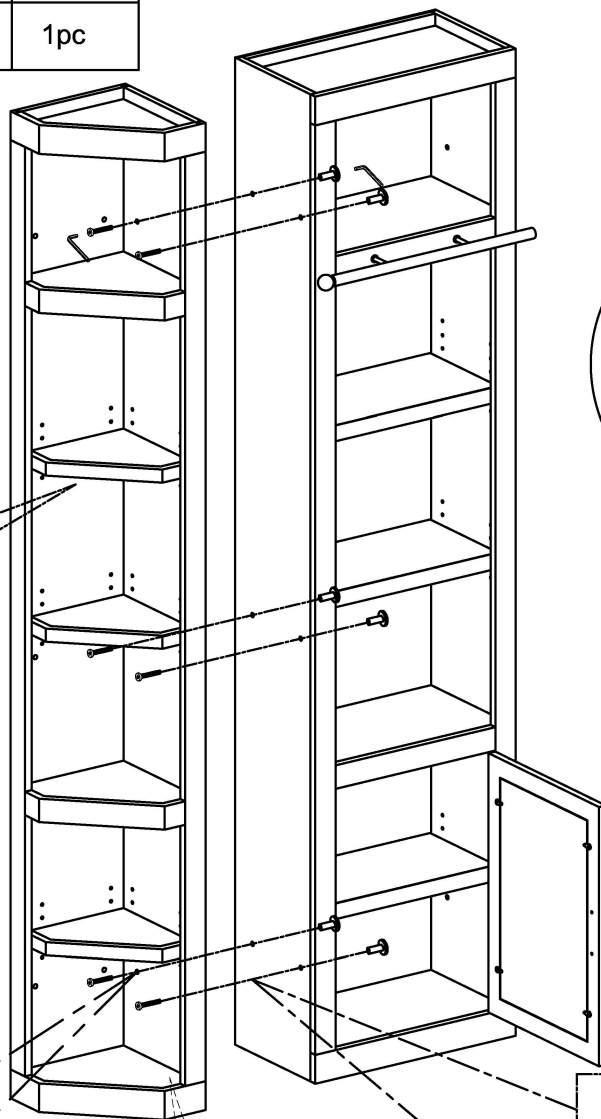

To adjust the shelf height, remove the four screws under each shelf pin. once removed, place shelf pins at desired height and re-screw shelf pins.

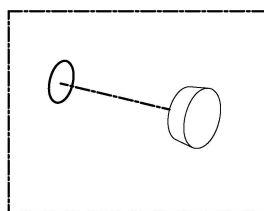

Remove the wood plugs before connecting the cabinets together.

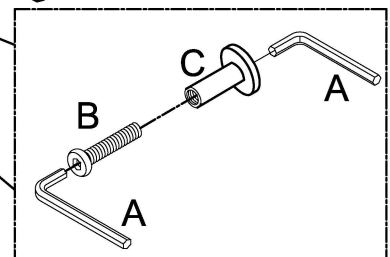
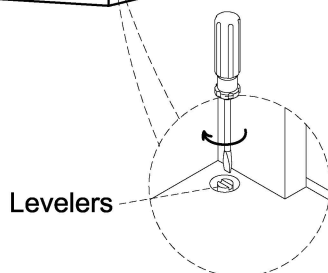

Align and connect cabinets with Connector Bolt (B) and Connector Cap (C).

Assembly Instruction

Item NO: CAT#456



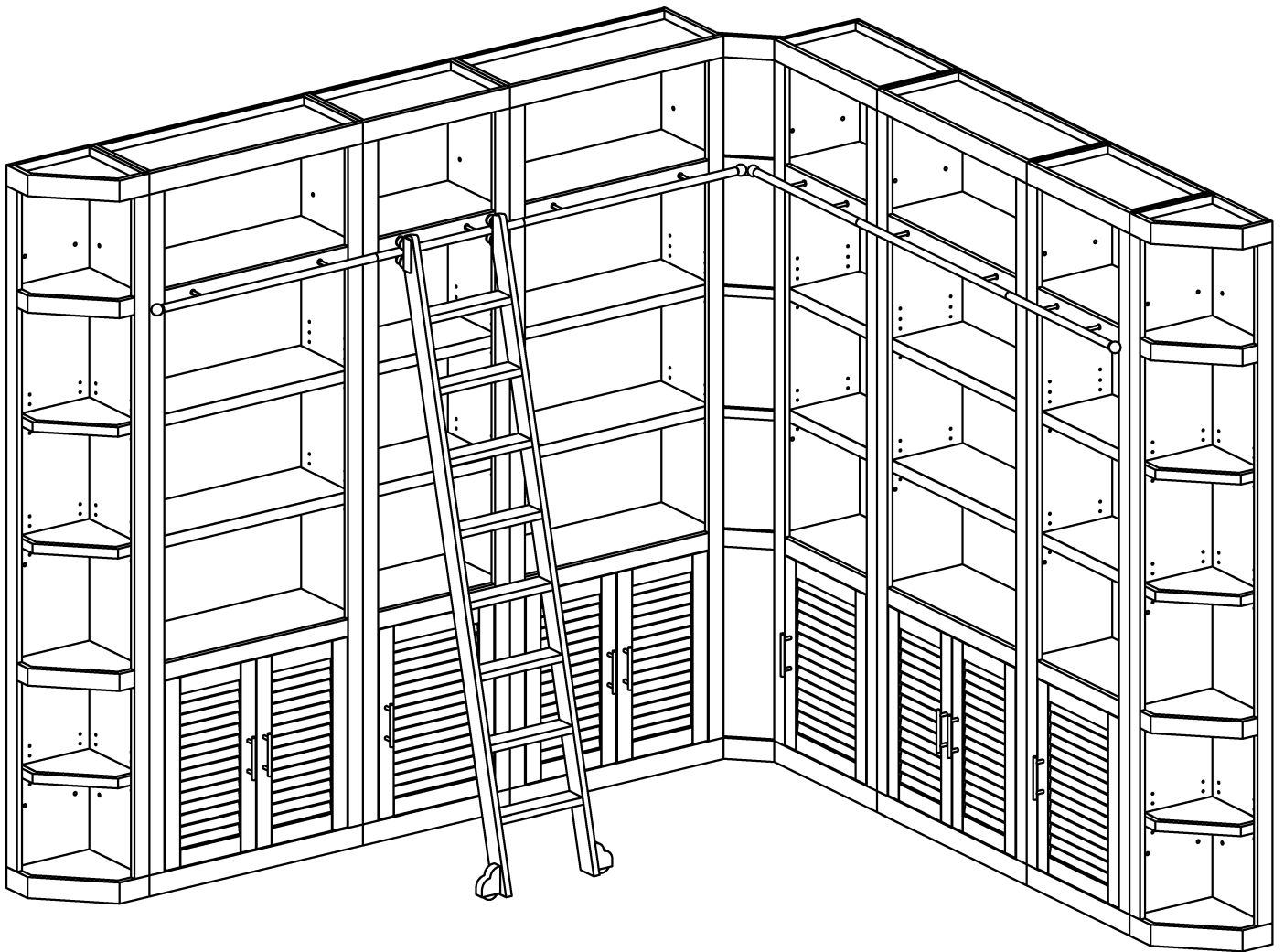



1/2



Assembly Instruction

Item NO: CAT#456

2/2

NO	Description	Sketch	Q'TY
A	Allen Wrench	4mm 	1pc
B	1-3/4" Bolt		6pcs
C	Ladder Rail Finial		2pc
D	Screw M8*1"		4pcs
O	Allen Wrench		1pc
	Touch up Pen		1pc

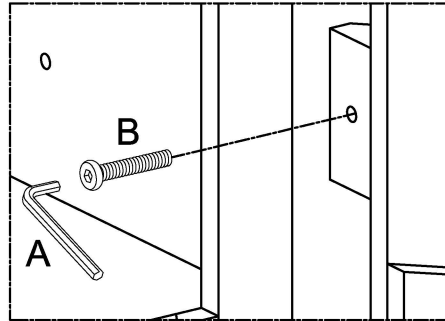

Corner Filler must be fully attached to one Bookcase and placed in its final position before being secured to a second Bookcase.

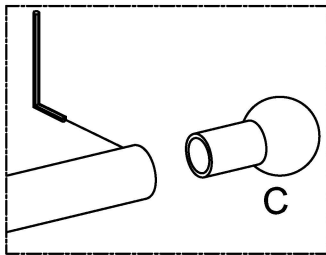
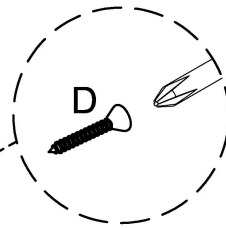

If setting up an end piece, use Allen Wrench to loosen retaining screw found on each rail end, secure Ladder Rail Finial (C) to ladder rail end to complete finished look.

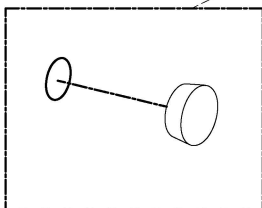
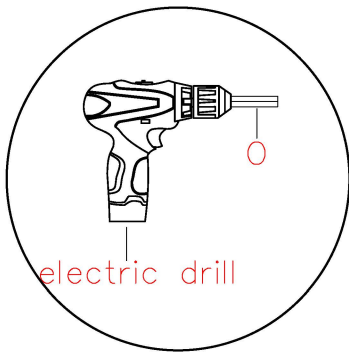

Remove the wood plugs before connecting the cabinets together.

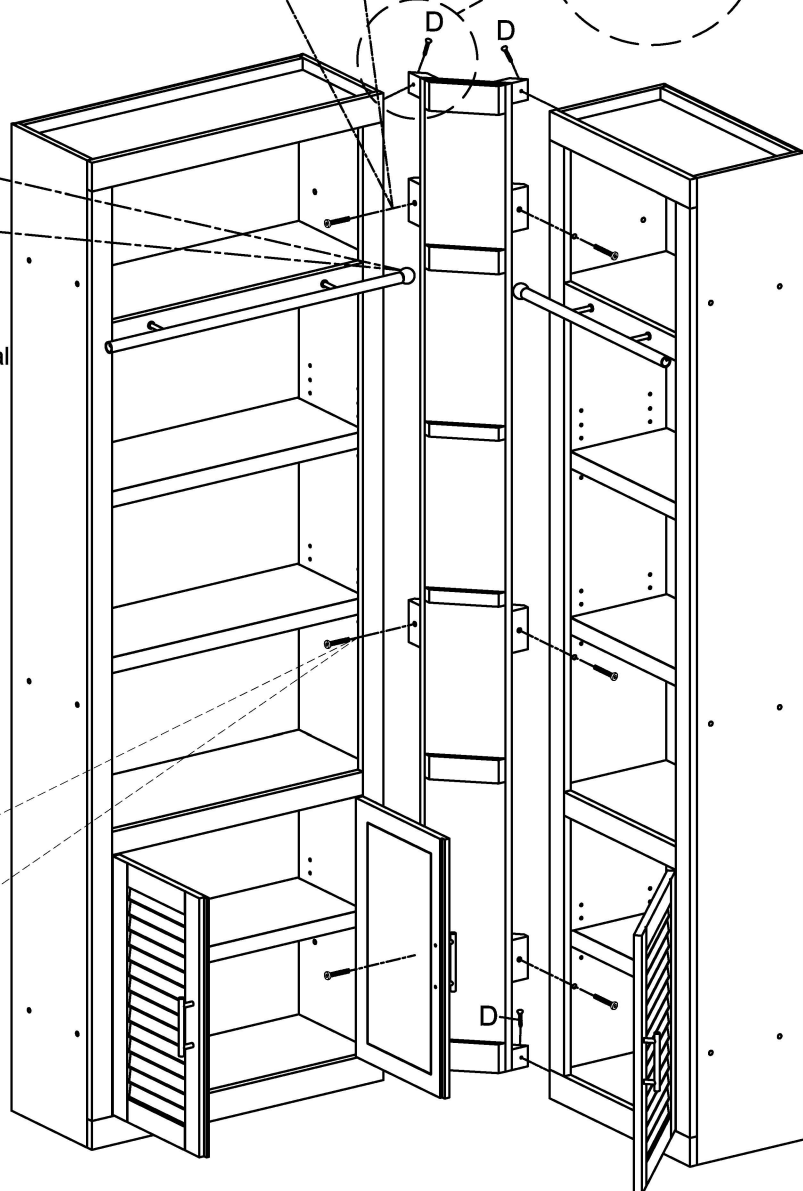

Assembly Instruction

Item NO: CAT#495

1/1

Hardwares

NO	Description	Sketch	Q'TY
	Touch up Pen		1pc

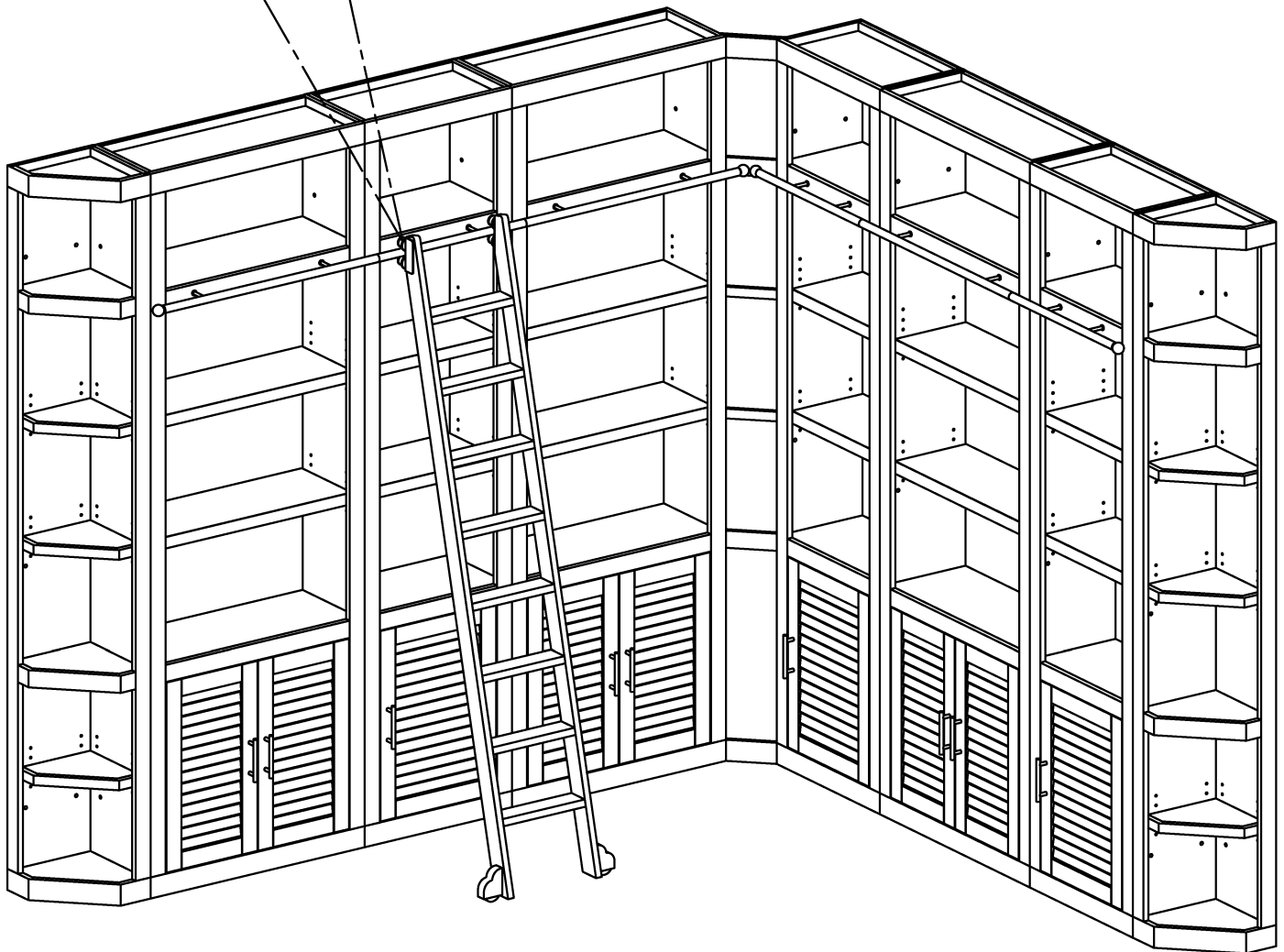
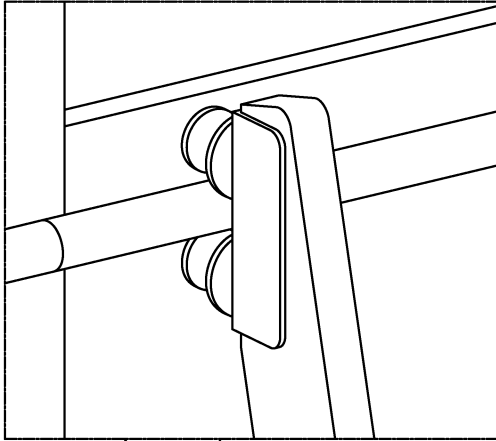

Assembly Instruction

Item NO: CAT#405

1/8

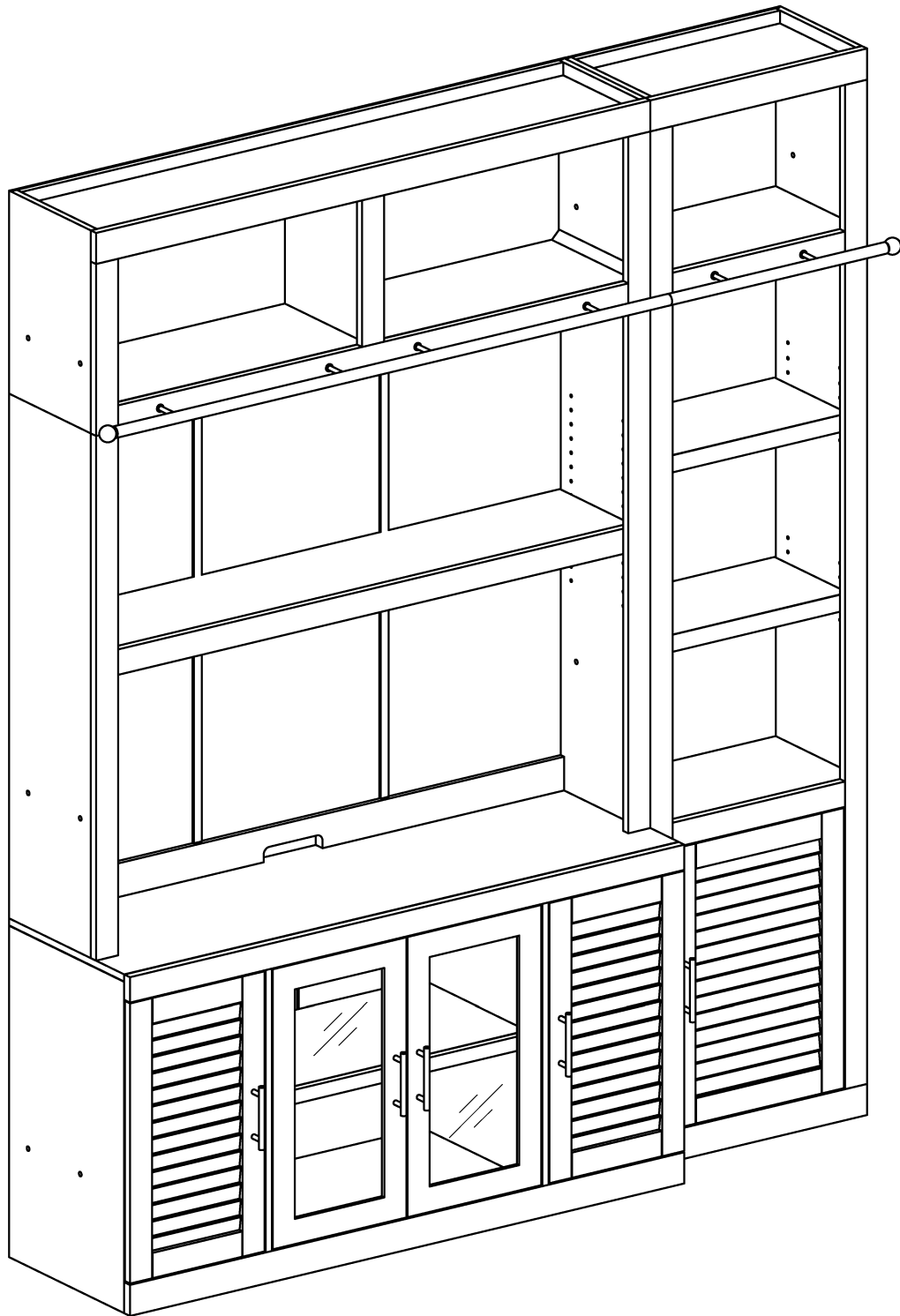

Assembly Instruction

Item NO: CAT#405

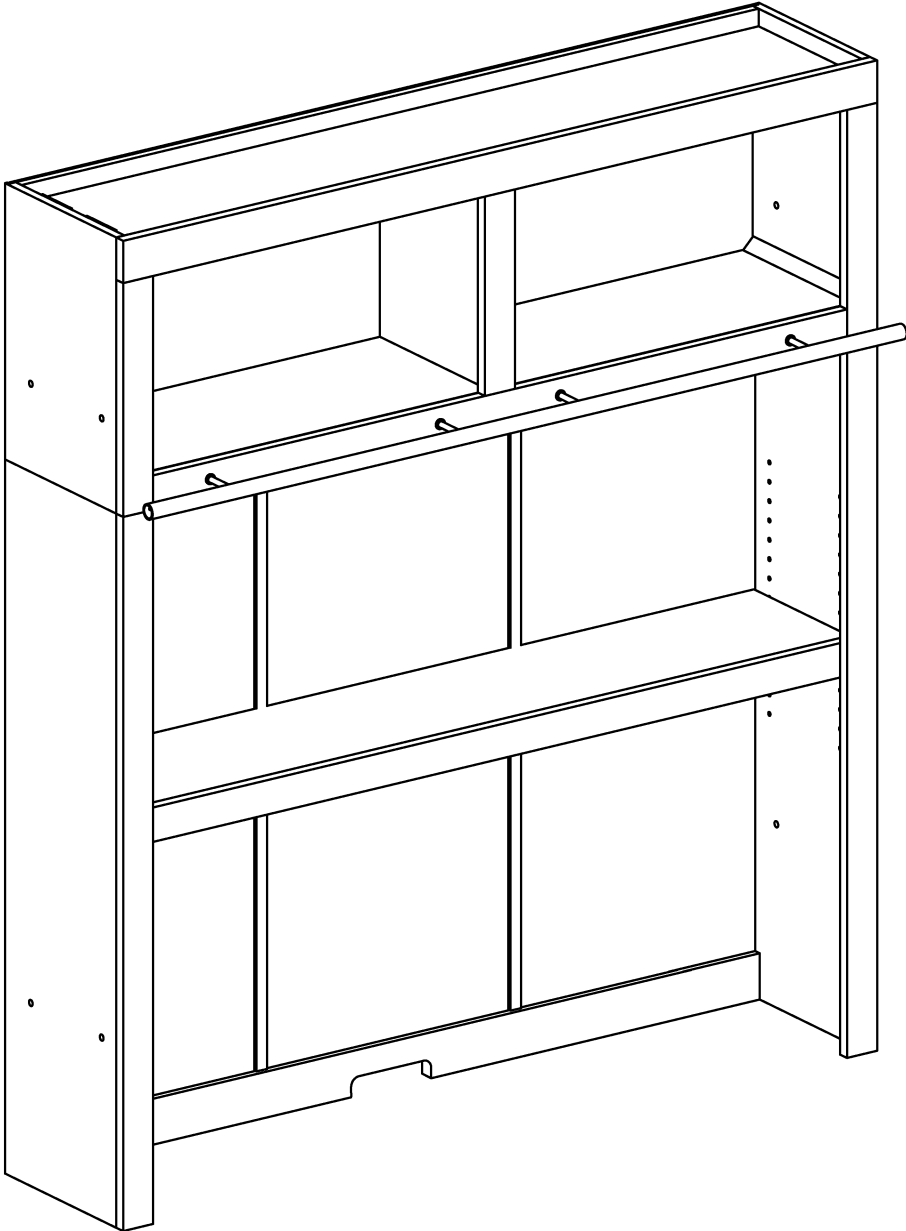



















Assembly Instruction

Item NO: CAT#405

3/8

Hardwares

NO	Description	Sketch	Q'TY
A	Cam bolt		4pcs
B	Cam lock		4pcs
C	Screw M6*15mm		18pcs
D	Large Shelf Bracket		4pcs
E	Screw M7*15mm		16pcs
F	25mm Bolt		6pcs
G	Screw Cap		4pcs
H	Ladder Rail Finial		1pc
I	Ladder Rail Coupler		1pc
J	Ladder rail		1pc

NO	Description	Sketch	Q'TY
K	Flat washer white		4pcs
L	Hex nut		4pcs
M	Lock washer		4pcs
N	Flat washer White zinc		4pcs
O	Allen Wrench 4mm		1pc
P	Allen Wrench 2.5mm		1pc
Q	Wrench		1pc
R	Allen Wrench		1pc
	Touch up Pen		1pc

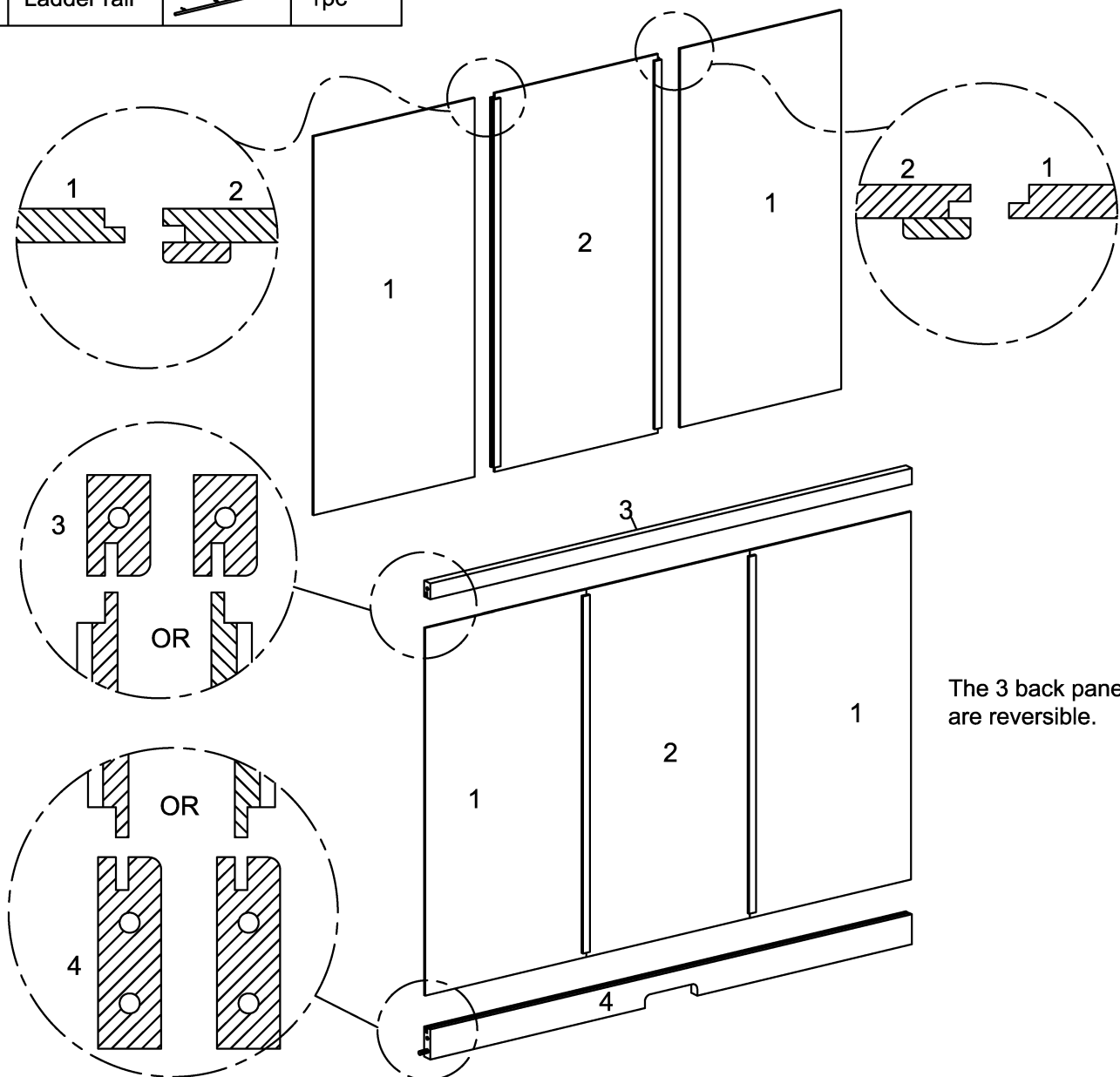

The 3 back panels are reversible.

Assembly Instruction

Item NO: CAT#405

4/8

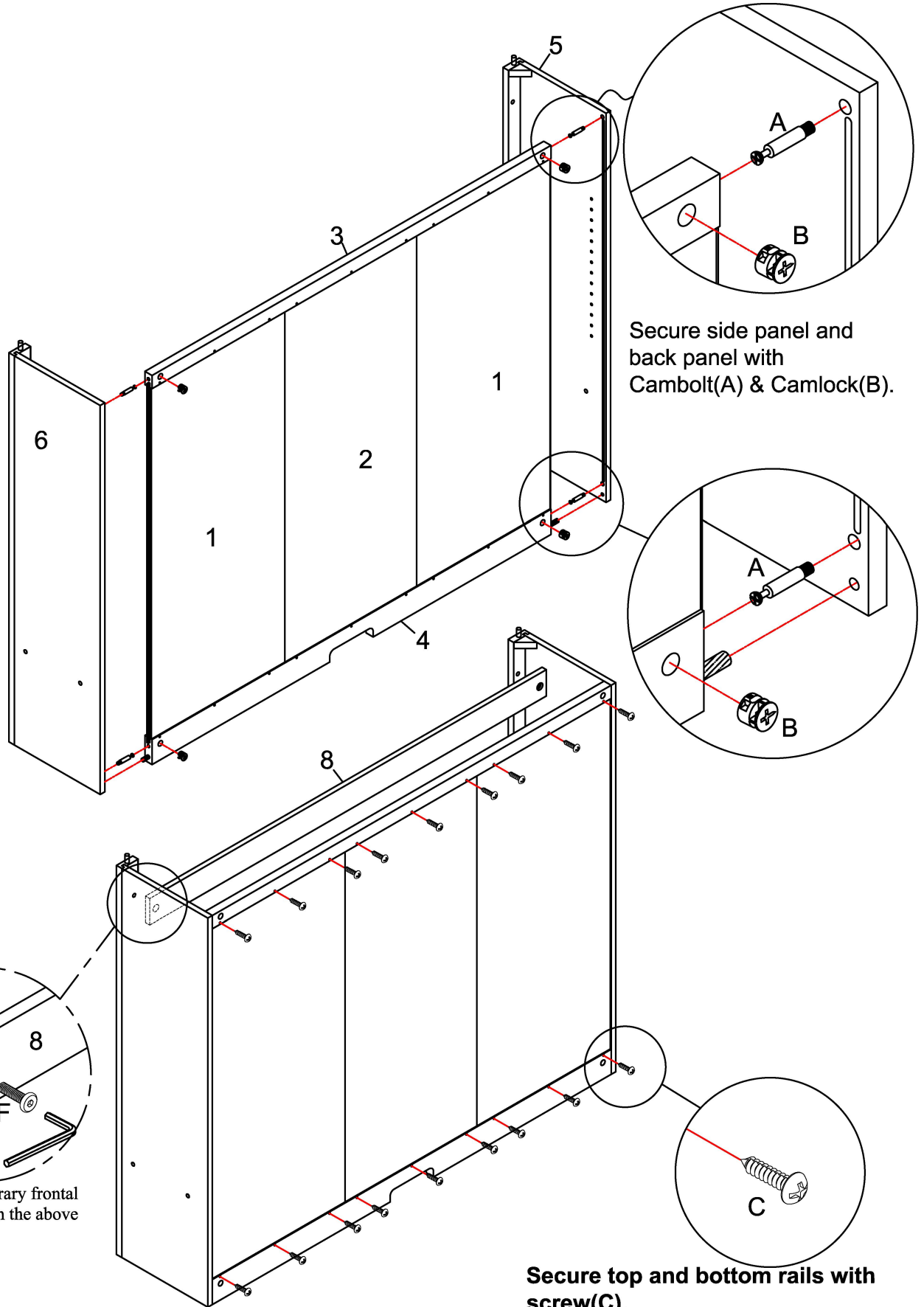

Secure side panel and back panel with Cambolt(A) & Camlock(B).

Connect the temporary frontal support as shown in the above diagram.

Secure top and bottom rails with screw(C).

Assembly Instruction

Item NO: CAT#405

5/8

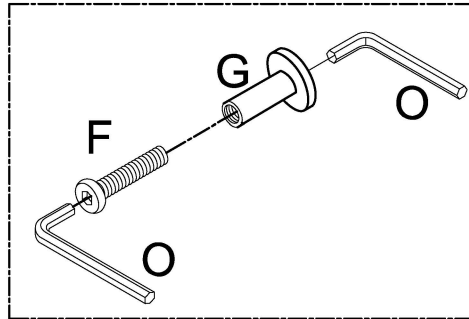
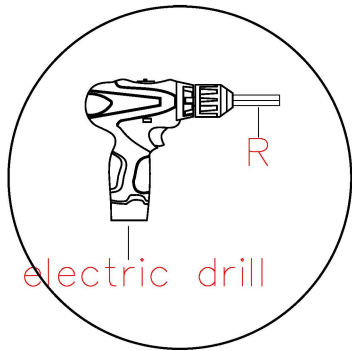

Align and connect cabinets with Connector Bolt (F) and Connector Cap (G).

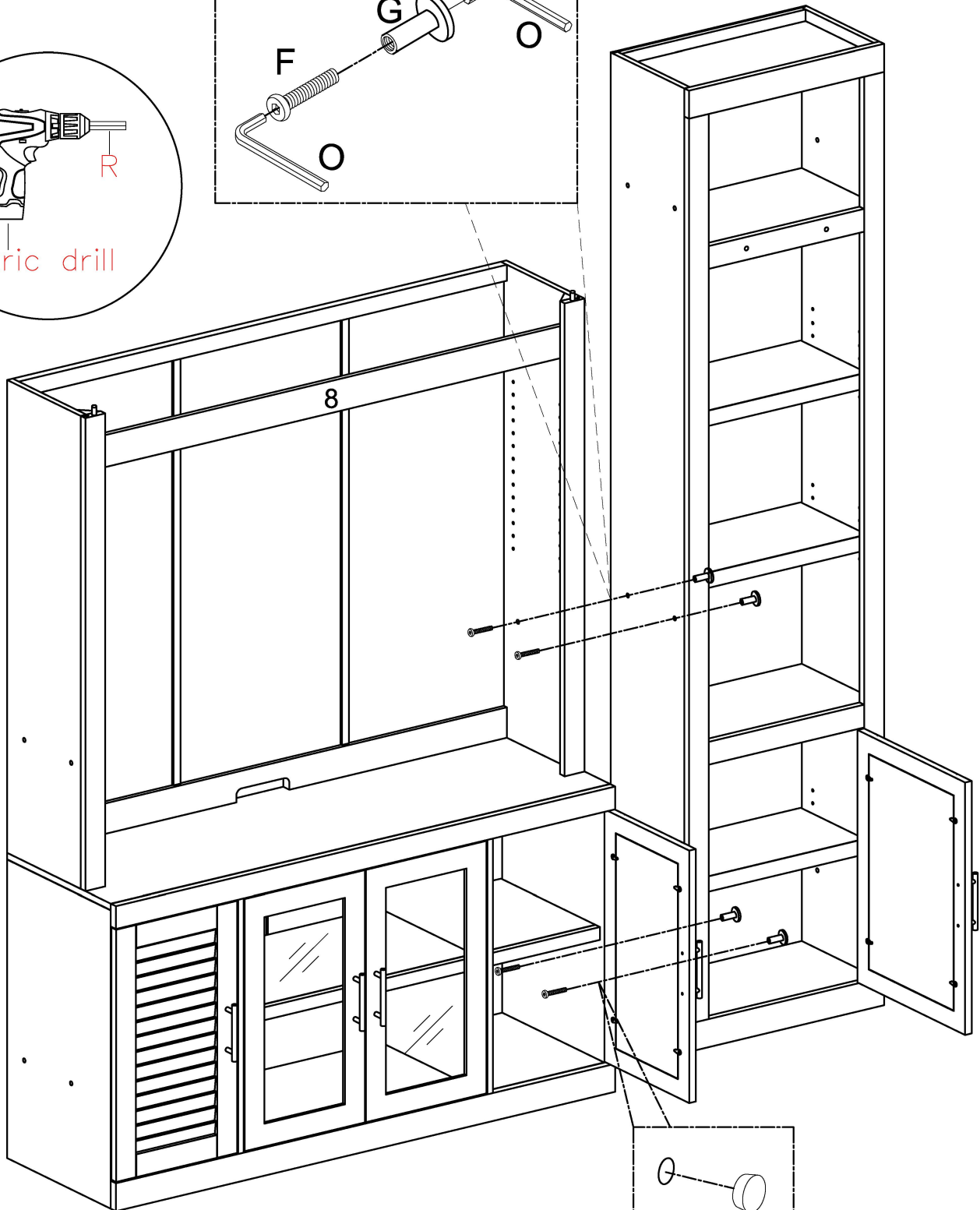

Remove the wood plugs before connecting the cabinets together.

Assembly Instruction

Item NO: CAT#405

6/8

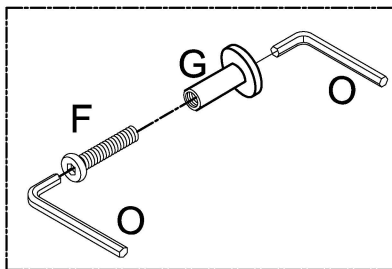
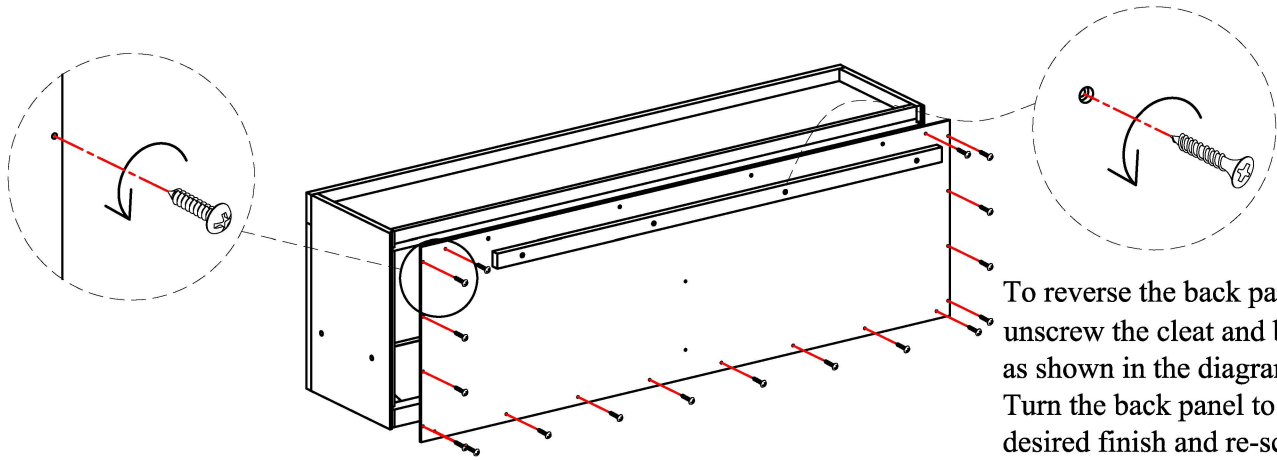

Align and connect cabinets with Connector Bolt (F) and Connector Cap (G).

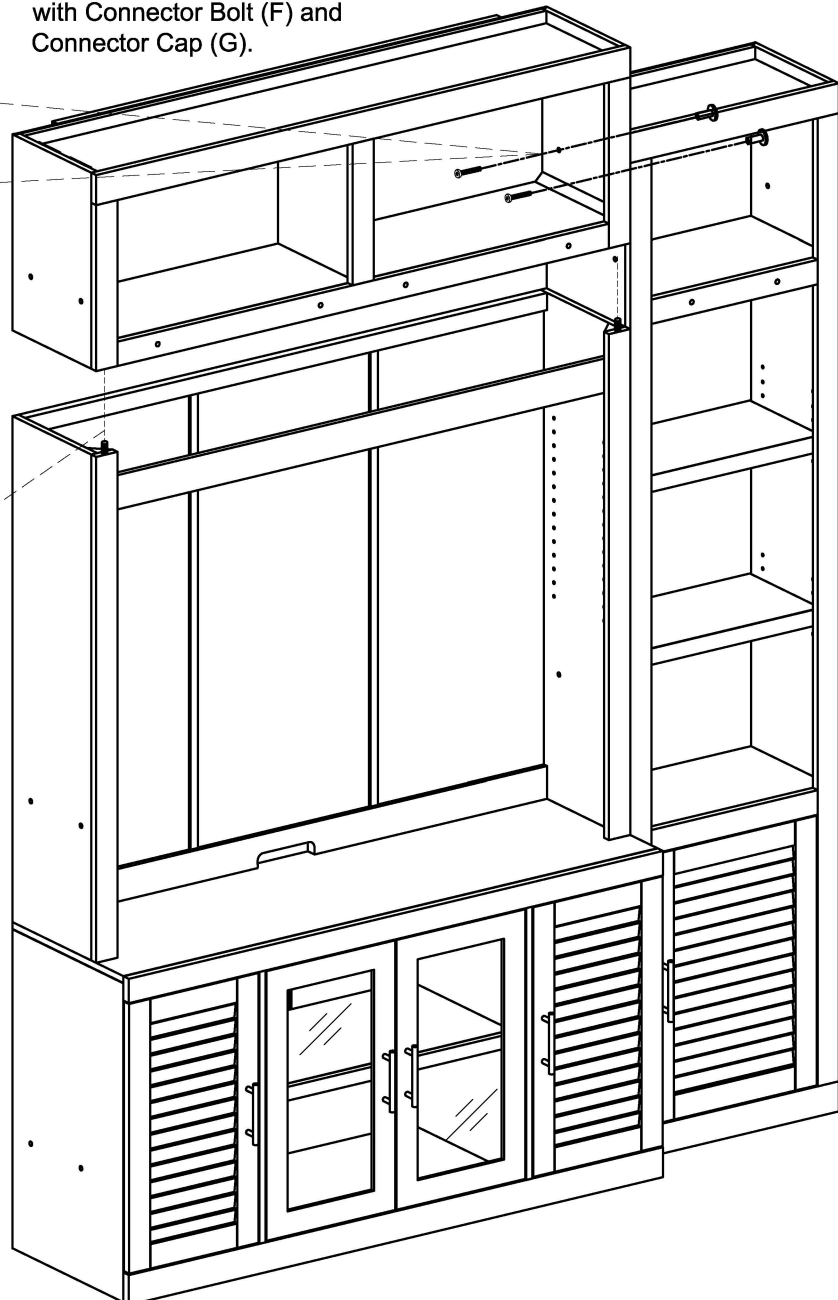
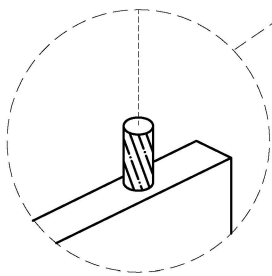

Assembly Instruction

Item NO: CAT#405

7/8

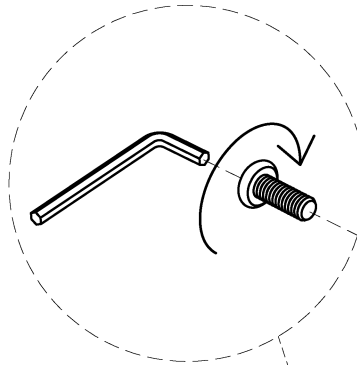

Remove temporary front rail(8) from Backpanel Midsection once the TV area shelf is assembled.

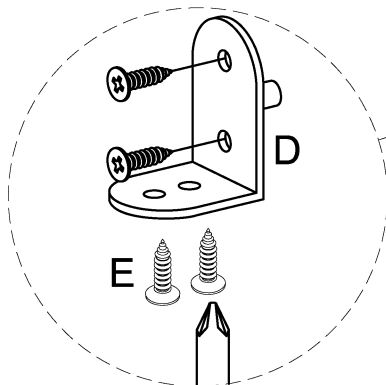
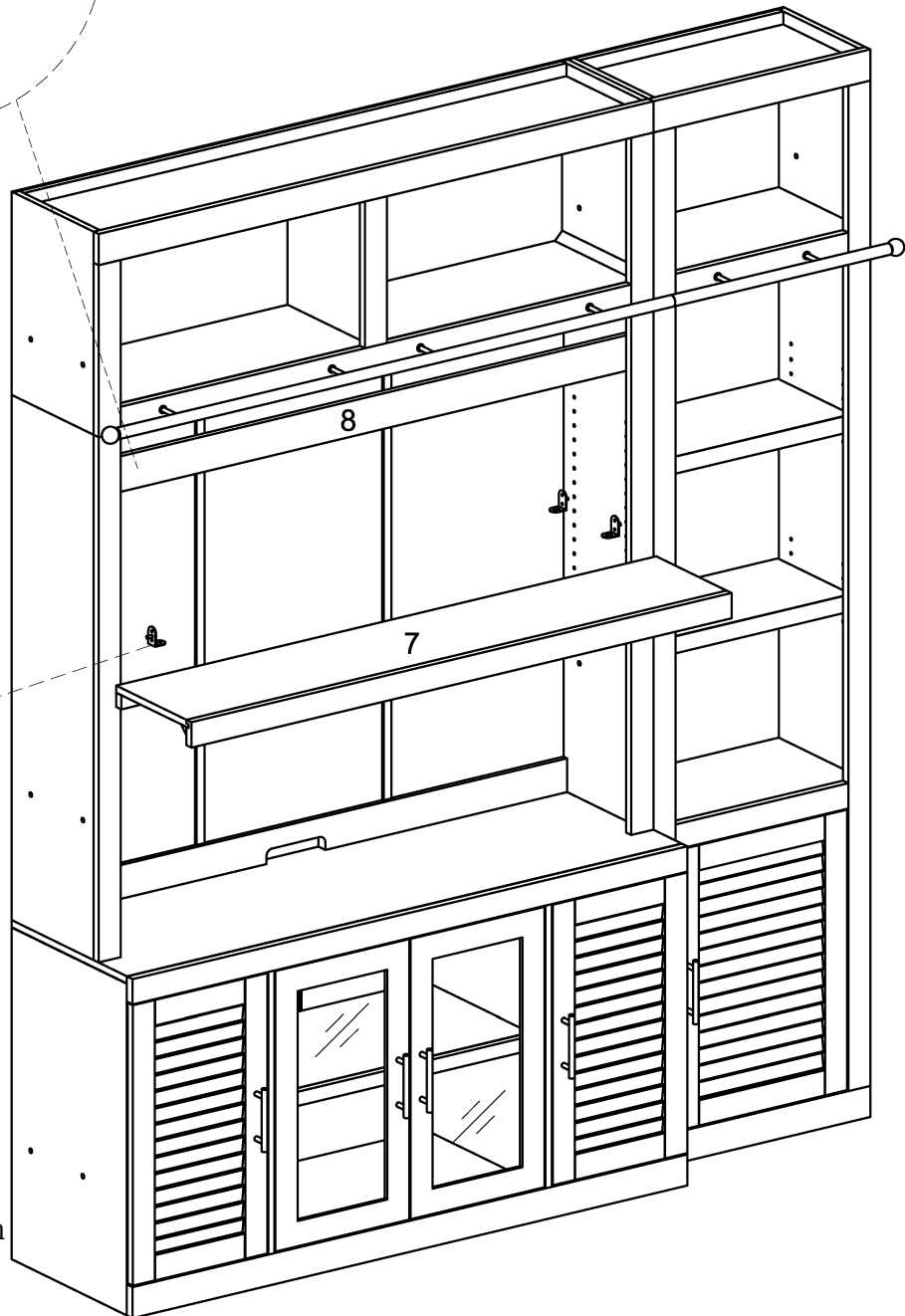

Install shelf pins at desired height in Backpanel Midsection & secure with screws(E). Place adjustable shelf on shelf brackets & secure with screws(E) in TV area.

Assembly Instruction

Item NO: CAT#405

8/8

Remove the decorative cap before mounting the ladder-rail.

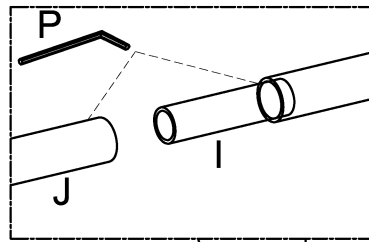
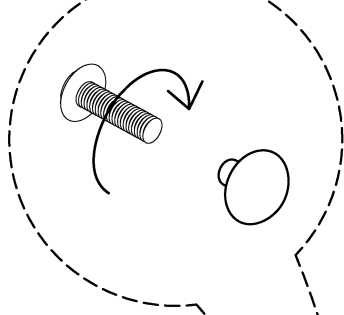

To connect ladder rails, loosen retaining screw found on each rail end, insert ladder rail coupler (I) about 1" on one side, and tighten. Align cabinets and push together, aligning ladder rails in the process. Tighten opposite retaining screw to secure ladder rail coupler.

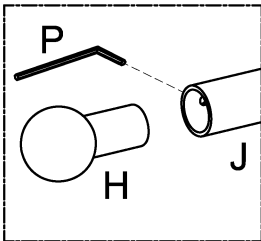

If setting up an end piece, use Allen Wrench(P) to loosen retaining screw found on each rail end, secure Ladder Rail Finial (H) to ladder rail end to complete finished look.

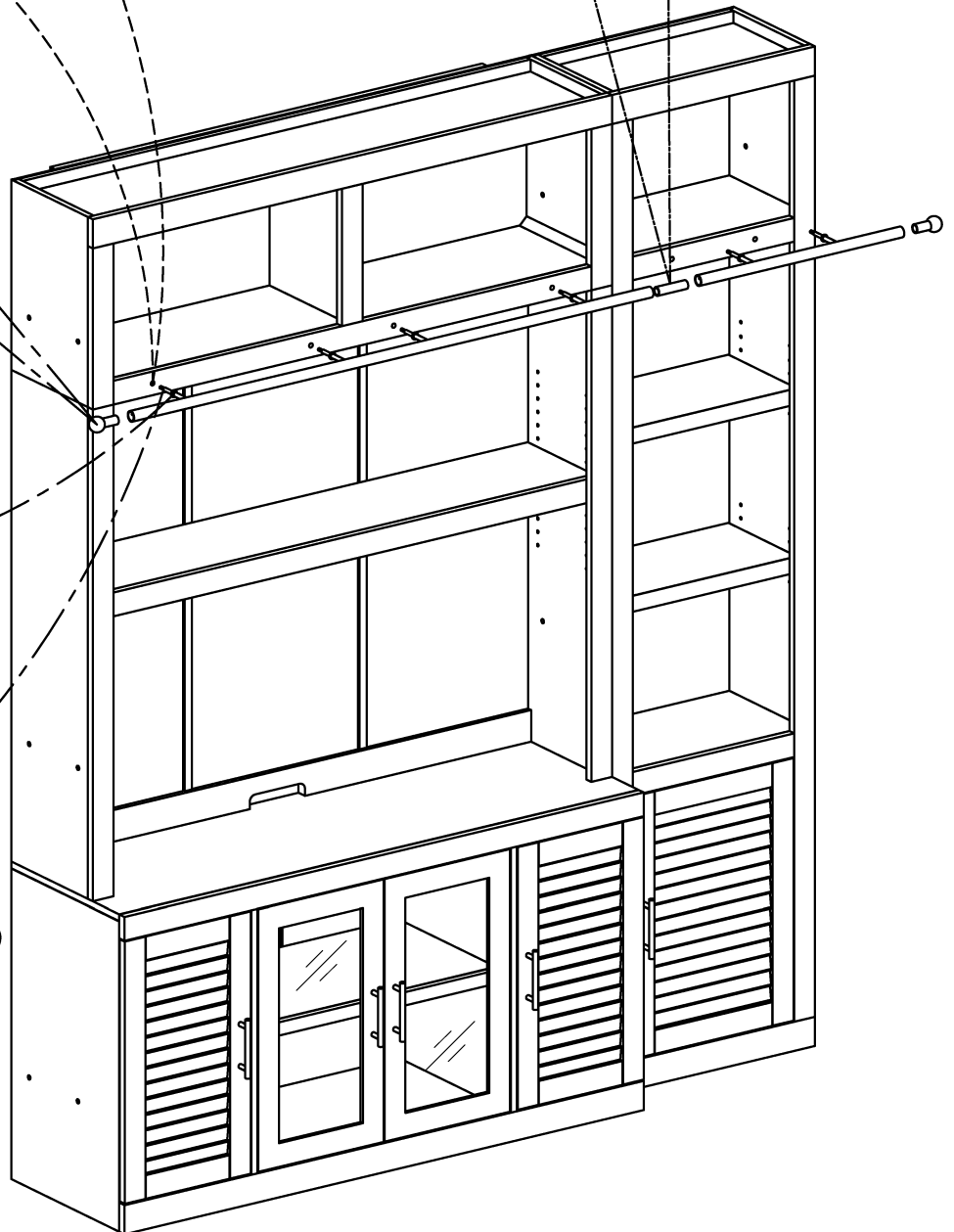
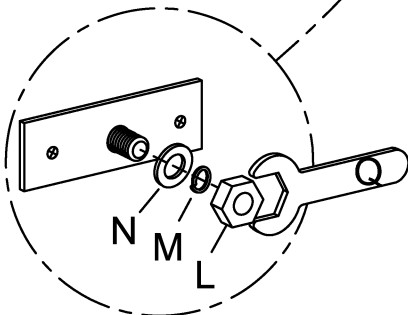
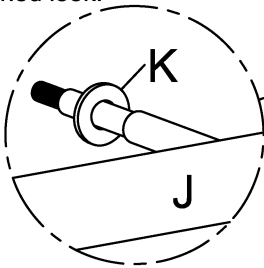

Assembly Instruction

Item NO: CAT#411

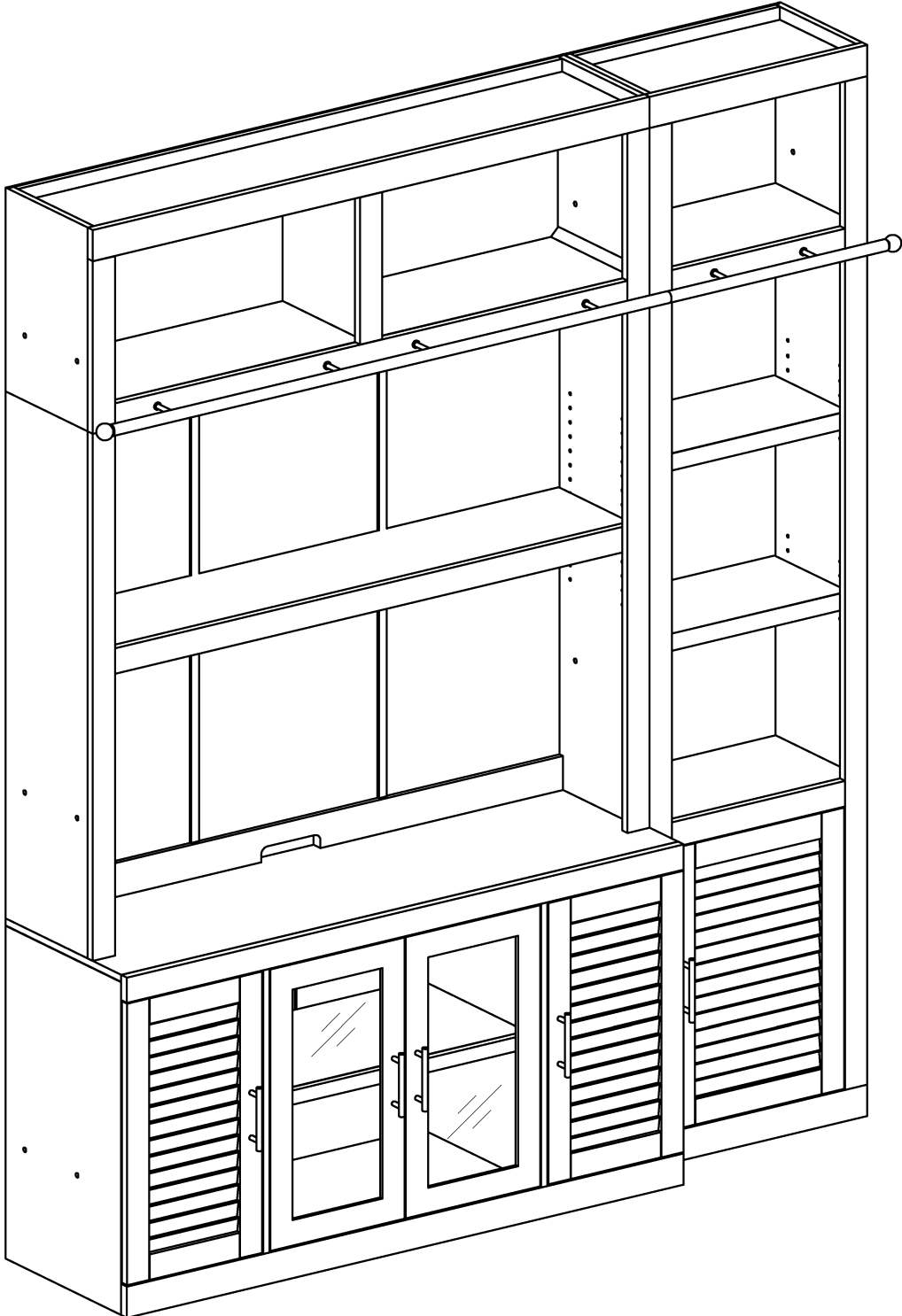







Assembly Instruction

Item NO: CAT#411

2/3

Hardwares

NO	Description	Sketch	Q'TY
A	Allen Wrench	4mm 	1pc
B	25mm Bolt		2pcs
C	Screw Cap		2pcs

NO	Description	Sketch	Q'TY
D	Allen Wrench		1pc
E	Allen Wrench		1pc
	Touch up Pen		1pc

Open the doors and take off the pulls installed on the back of doors, then reattach the pulls on the front side of doors as shown.

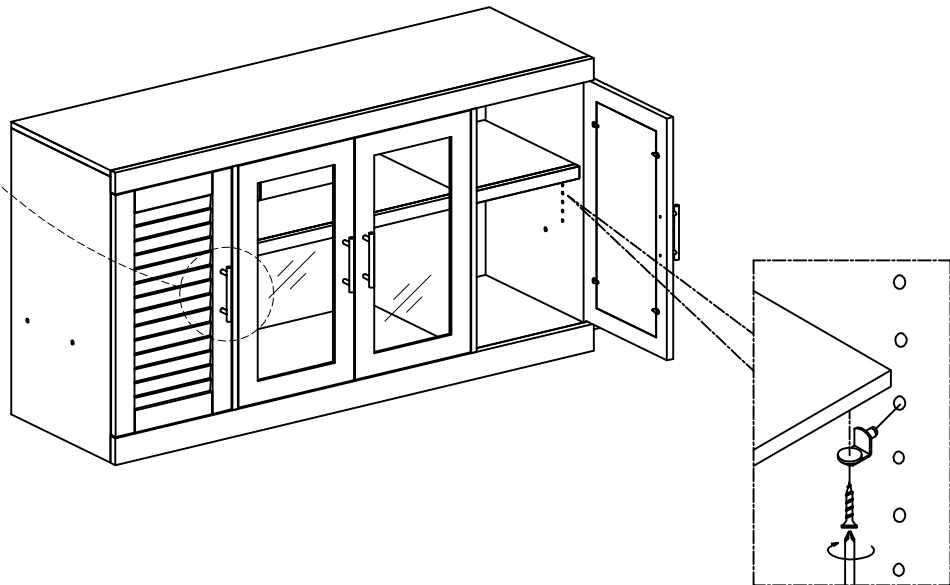
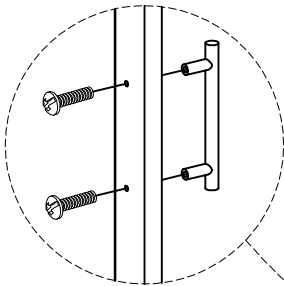

Take down the shelves and reinstall the shelves to the desired position as shown.

Assembly Instruction

Item NO: CAT#411

3/3

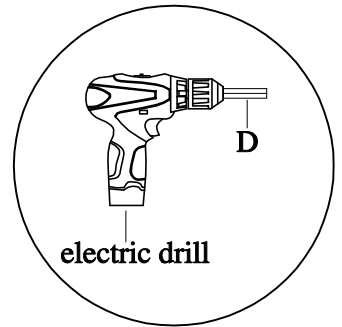
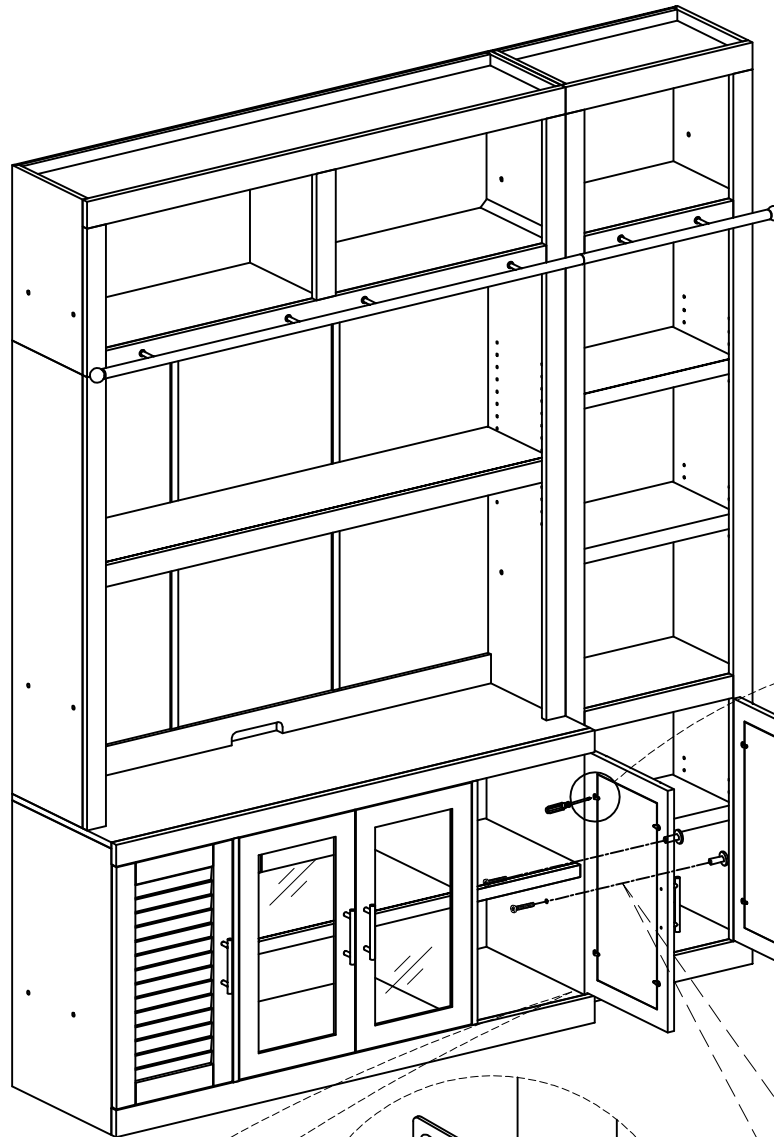

Use a screwdriver to loosen the screw of each Tab before flipping up the Tabs.

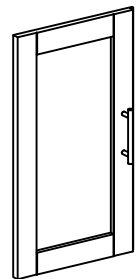
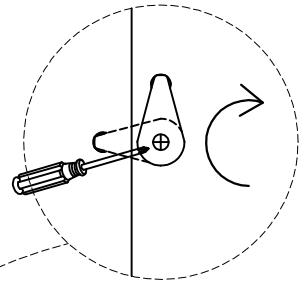

The front wood door panel is reversible. To change the the door panel, flip up each tab and push door panel out. Turn the panel around and place back inside the door and flip the tabs down to hold it in place.

Inside the bottom panel on the forward RSF side is a cap with the leveler below. To adjust the leveler remove the cap and turn the leveler to adjust the height of the bookcase with Allen wrench(E).

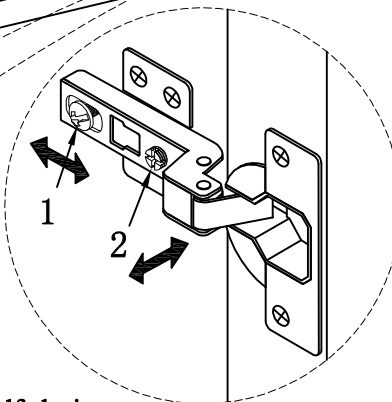
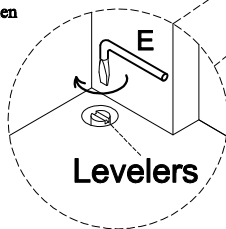

The library self closing hinges can be adjusted with the above diagram screws.

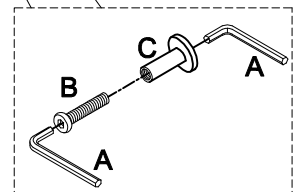

Align and connect cabinets with Connector Bolt (B) and Connector Cap (C).

Assembly Instruction

Item NO: CAT#460H

1/5

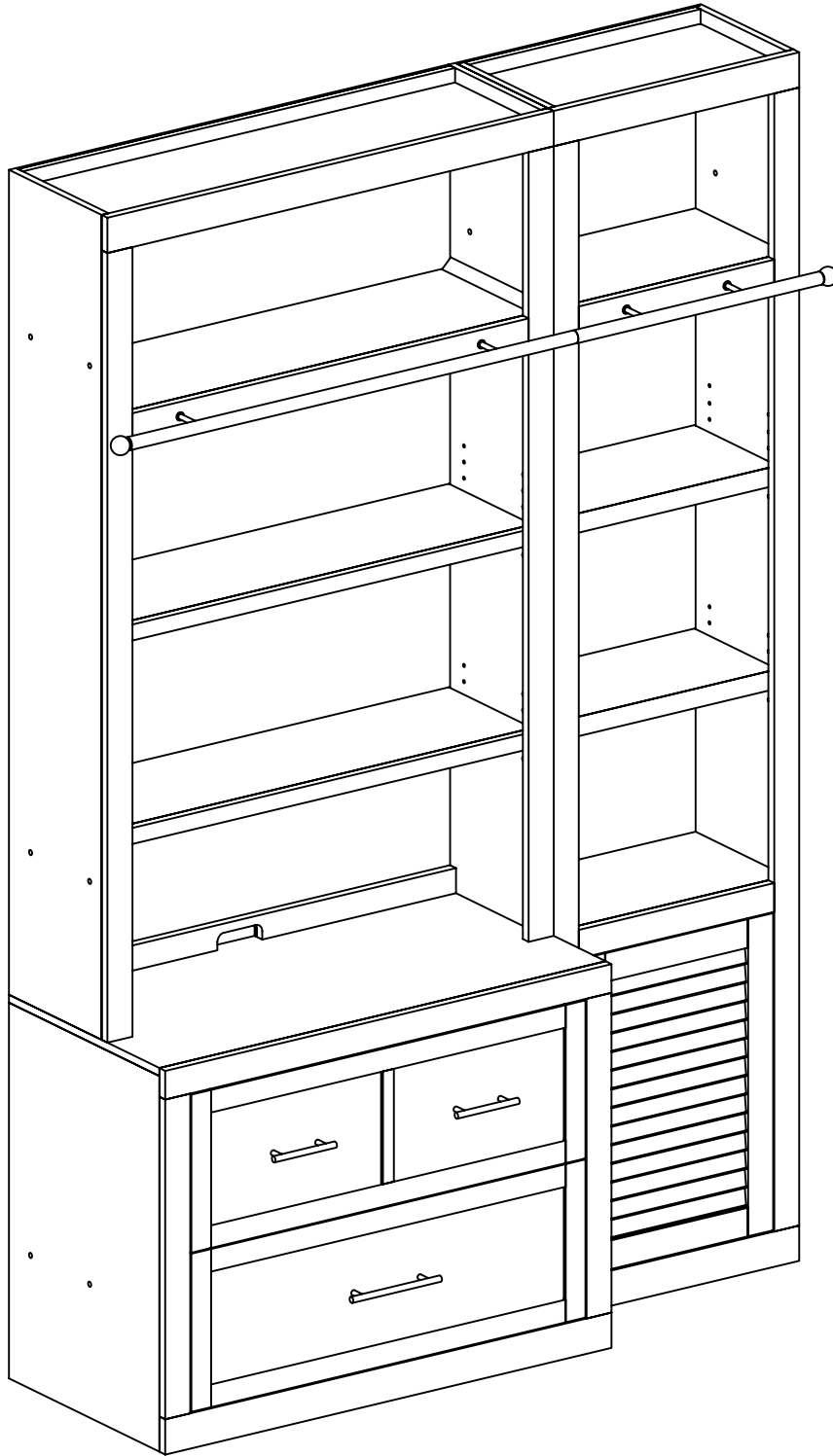













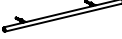

Assembly Instruction

Item NO: CAT#460H

2/5

Hardwares

NO	Description	Sketch	Q'TY
A	Wrench		1pc
B	Allen Wrench	4mm 	1pc
C	Allen Wrench	2.5mm 	1pc
D	25mm Bolt		4pcs
E	Screw Cap		4pcs
F	Ladder Rail Finial		1pc
G	Ladder Rail Coupler		1pc
H	Ladder rail		1pc

NO	Description	Sketch	Q'TY
I	Flat washer white		2pcs
J	Hex nut		2pcs
K	Lock washer		2pcs
L	Flat washer White zinc		2pcs
M	Screw M6*15mm		2pcs
O	Allen Wrench		1pc
	Touch up Pen		1pc

Remove the decorative cap before mounting the ladder rail.

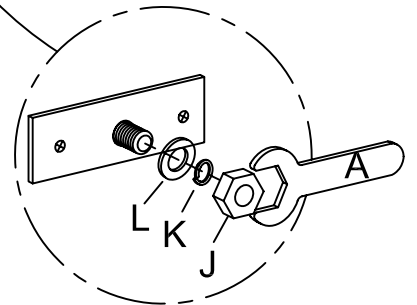
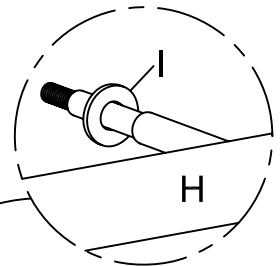
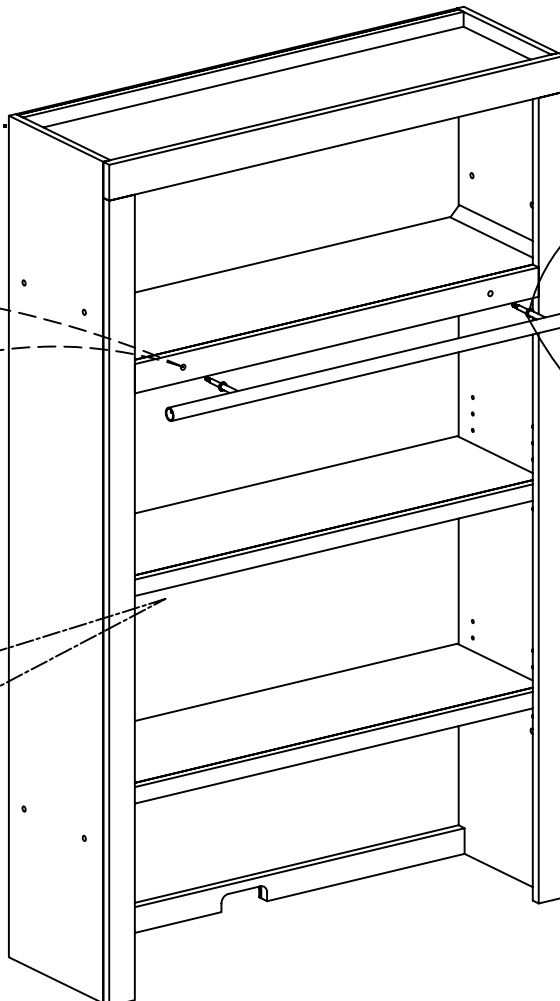
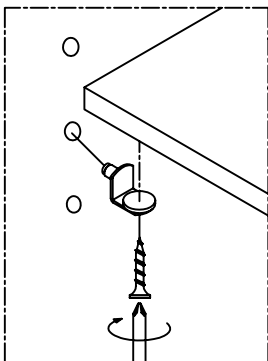
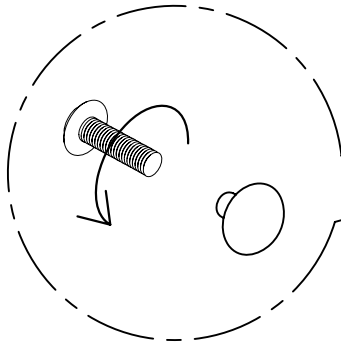

To adjust the shelf height, remove the four screws under each shelf pin. once removed, place shelf pins at desired height and re-screw shelf pins.

Assembly Instruction

Item NO: CAT#460H

3/5

To reverse the back panel, unscrew the cleat and back panel as shown in the diagram below. Turn the back panel to the desired finish and re-screw.

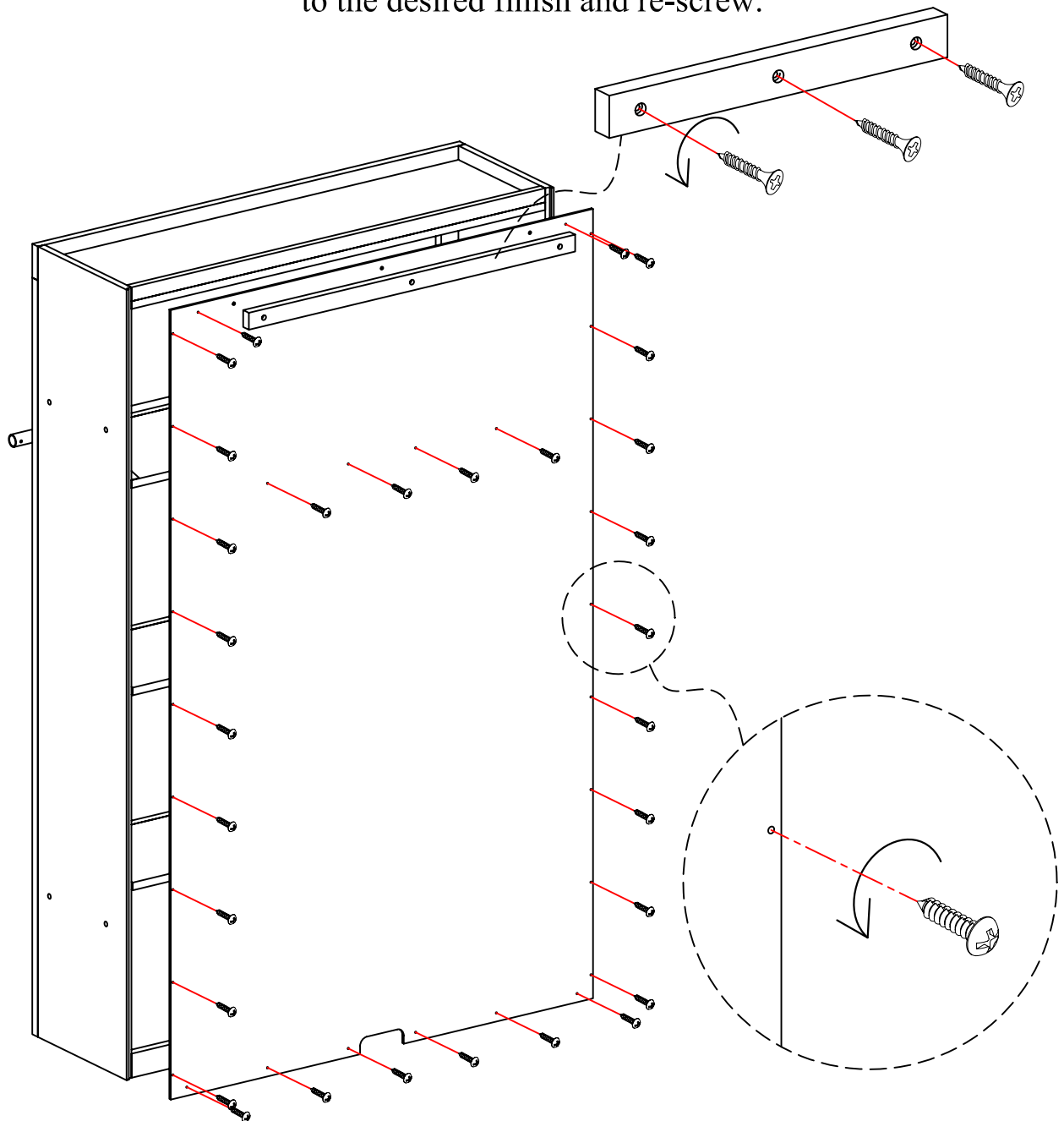

Assembly Instruction

Item NO: CAT#460H

4/5

To connect ladder rails, loosen retaining screw found on each rail end, insert ladder rail coupler (G) about 1" on one side, and tighten. Align cabinets and push together, aligning ladder rails in the process. Tighten opposite retaining screw to secure ladder rail coupler.

If setting up an end piece, use Allen Wrench(C) to loosen retaining screw found on each rail end, secure Ladder Rail Finial (F) to ladder rail end to complete finished look.

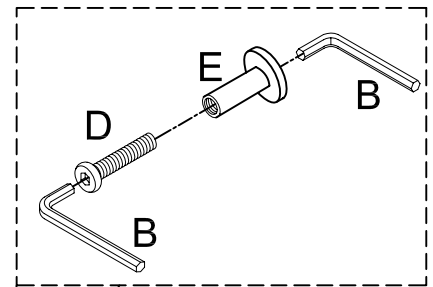
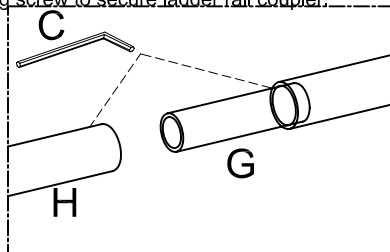

Align and connect cabinets with Connector Bolt (D) and Connector Cap (E).

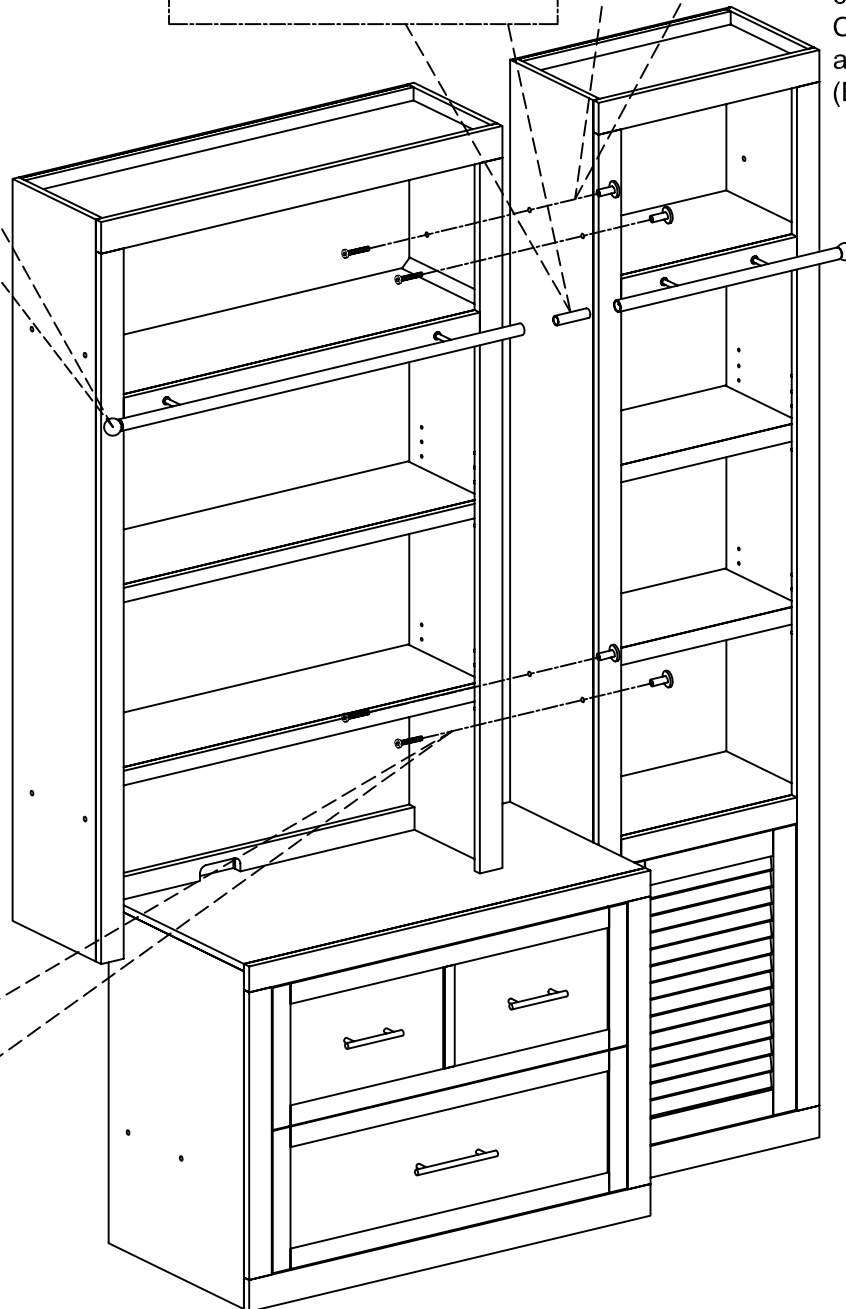
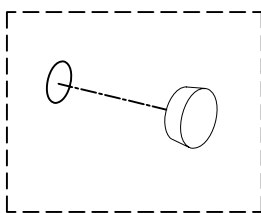
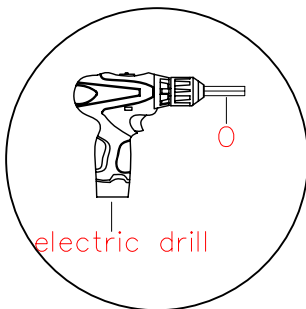
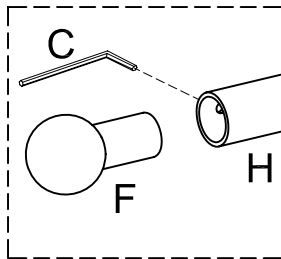

Assembly Instruction

Item NO: CAT#460H

5/5

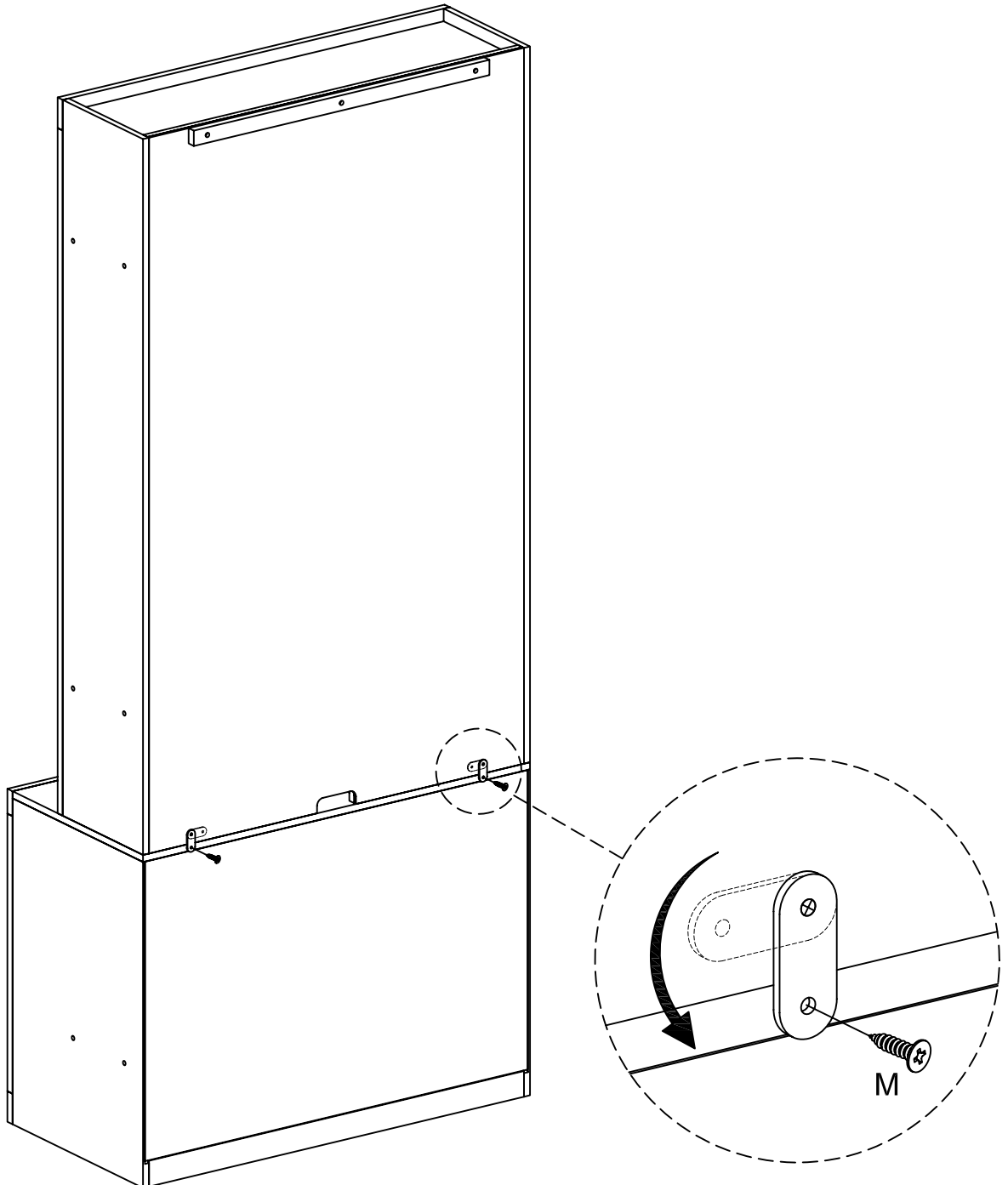

Loosen screw on coupling plate found on the back of Hutch, rotate 90 degree clockwise, retighten screw. Using Screw(M), secure coupling plate to rear of Base Top as shown above.

Assembly Instruction

Item NO: CAT#476F

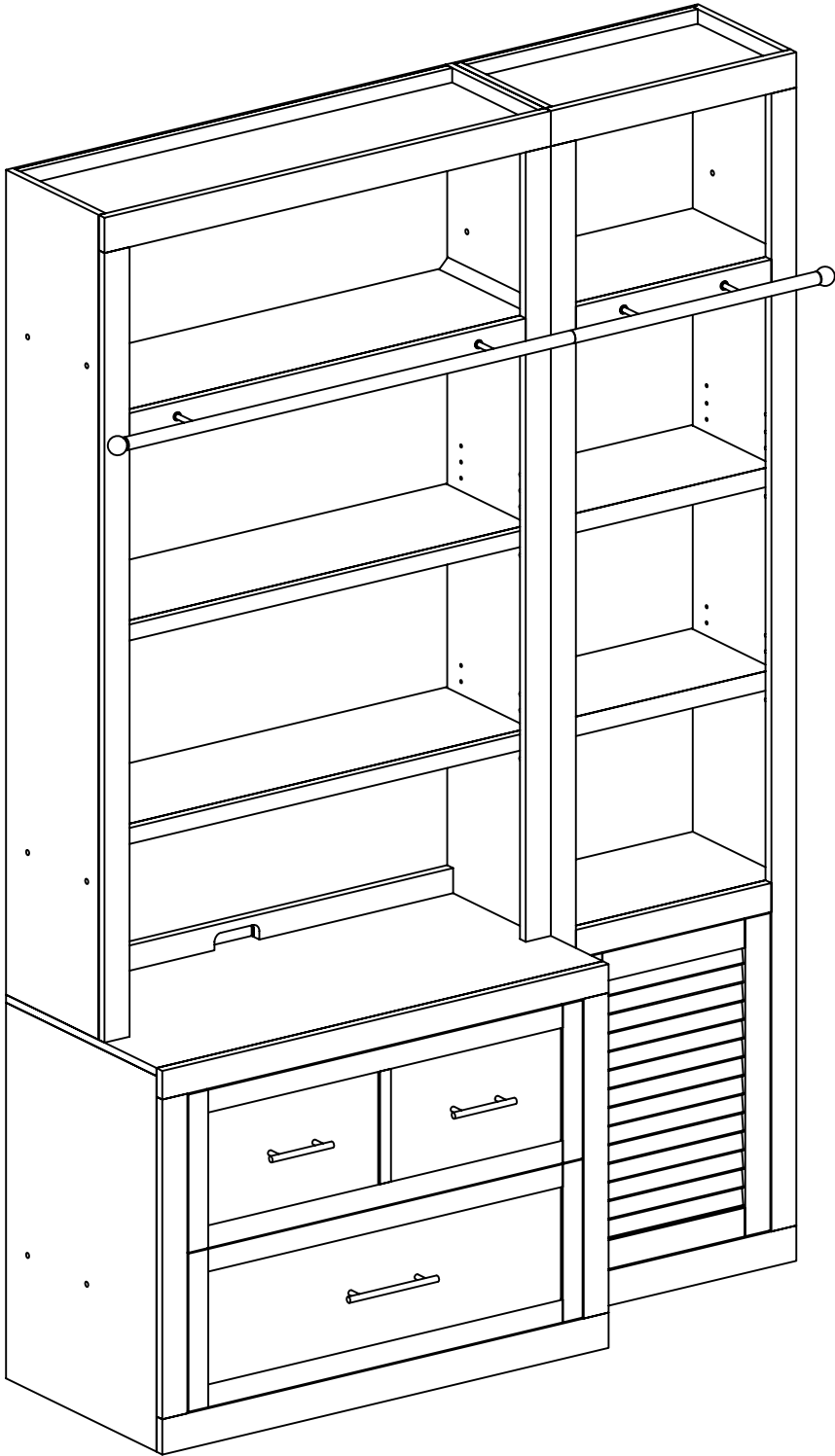









Assembly Instruction

Item NO: CAT#476F

2/3

Hardwares

NO	Description	Sketch	Q'TY
A	Allen Wrench	4mm 	1pc
B	25mm Bolt		2pcs
C	Screw Cap		2pcs
D	Small Pull		2pcs
E	Big Pull		1pcs
F	Screw for pull		6pcs

NO	Description	Sketch	Q'TY
O	Allen Wrench		1pc
	Touch up Pen		1pc

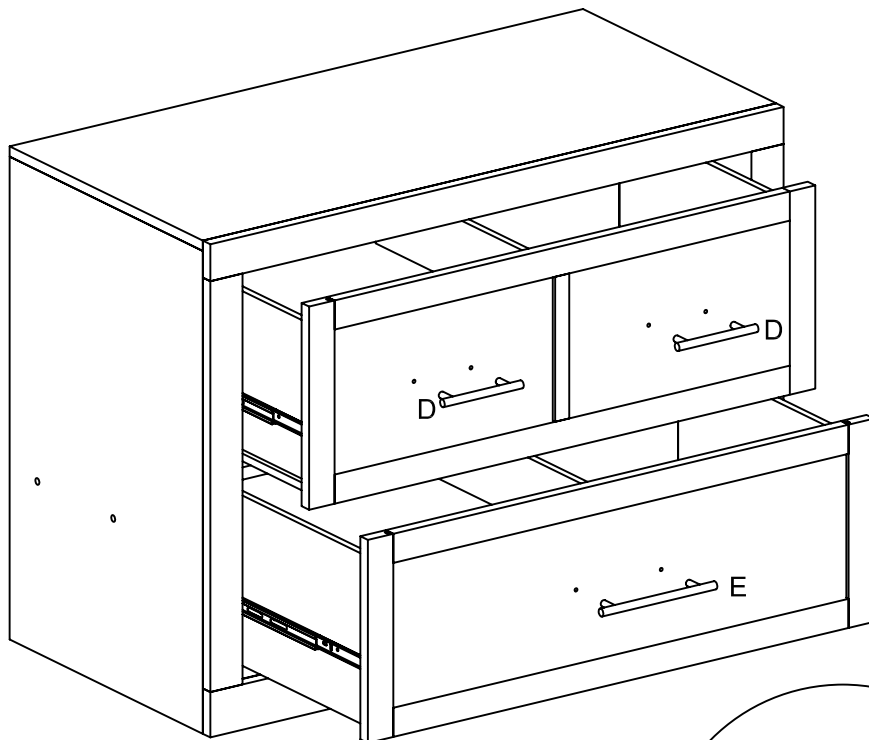

Open the drawer using the white cord then install the Pull (D & E) using Screws (F).

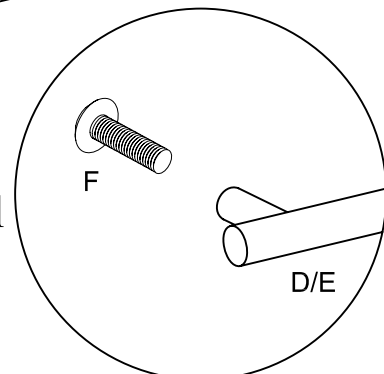

Assembly Instruction

Item NO: CAT#476F

3/3

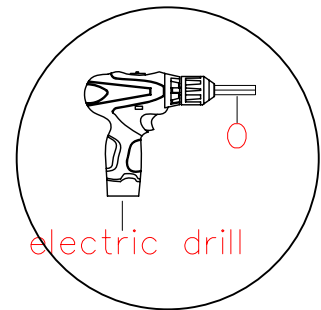
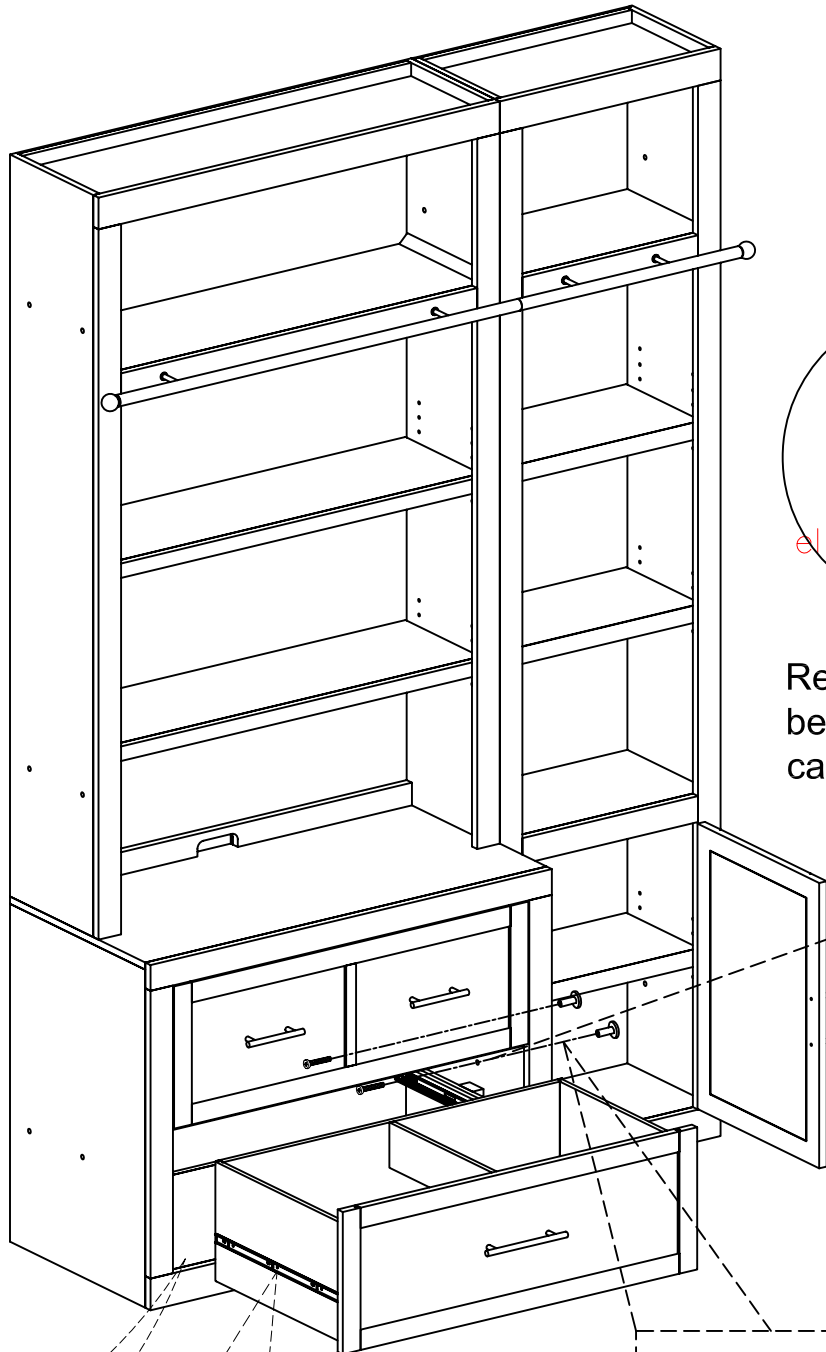

Remove the wood plugs before connecting the cabinets together.

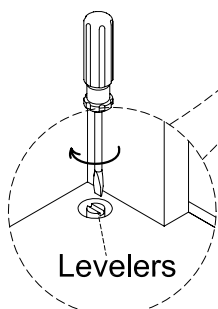
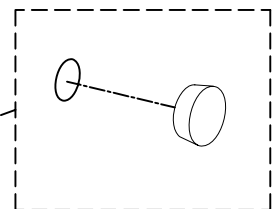

Remove the cap of the leg levelers on the bottom of the File base and adjust it

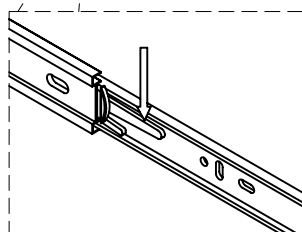

To remove the wood plugs and adjust the levelers on the File base, you will need to detach the drawers. To remove the drawers, press on the levers located on both sides of the drawer simultaneously while pulling the drawer out.

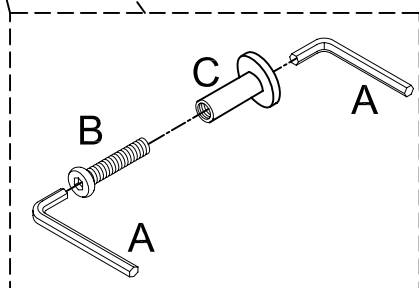

Align and connect cabinets with Connector Bolt (B) and Connector Cap (C).

Assembly Instruction

Item NO: CAT#461D

1/5

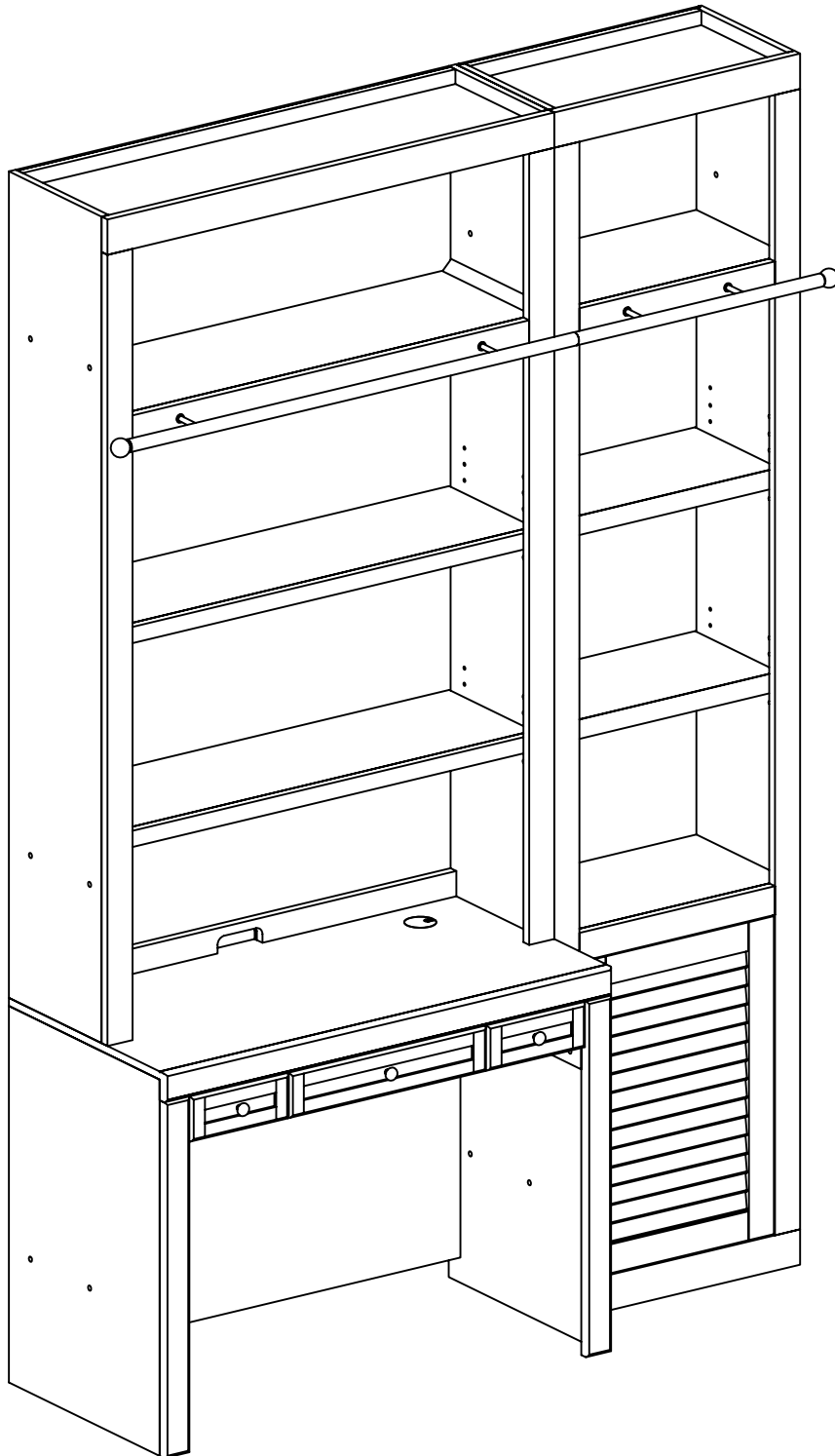

Assembly Instruction

Item NO: CAT#461D

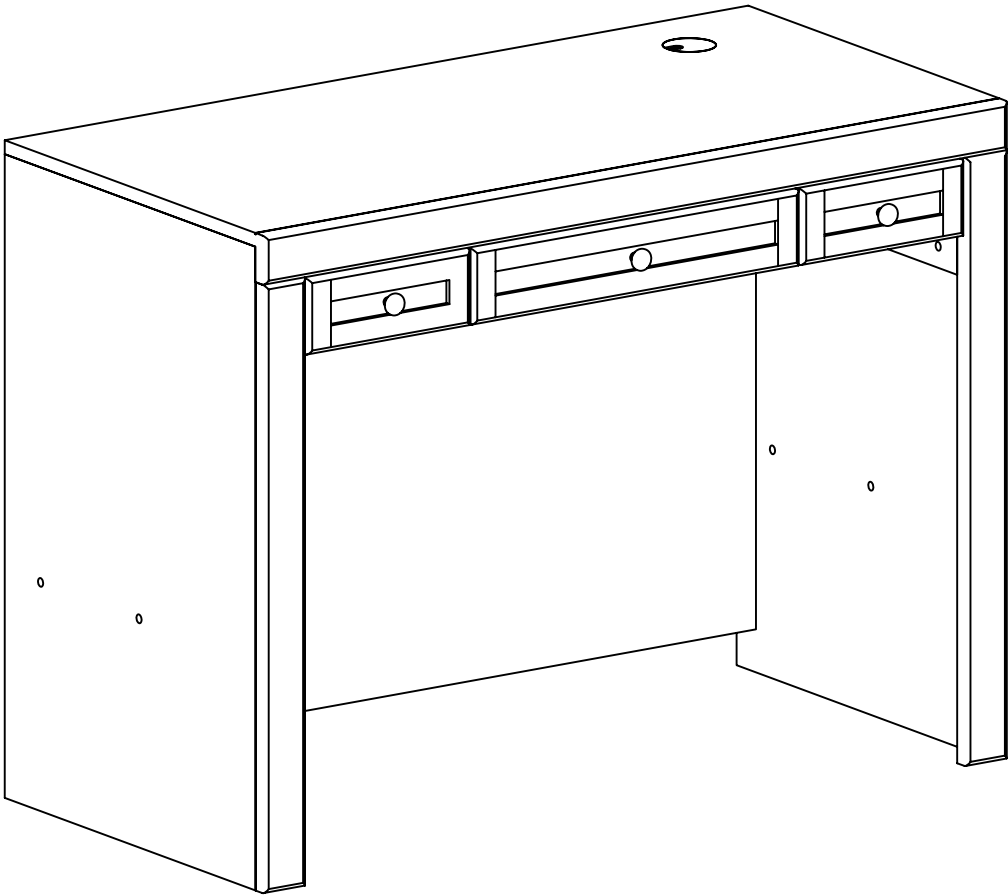









Assembly Instruction

Item NO: CAT#461D

3/5

Hardwares

NO	Description	Sketch	Q'TY
A	Allen Wrench	4mm 	1pc
B	1-1/4" Bolt		12pcs
C	Lock washer		12pcs
D	Flat washer		12pcs
E	Wood dowel		4pcs

NO	Description	Sketch	Q'TY
F	Wire Grommet		1pc
G	25mm Bolt		2pcs
H	Screw Cap		2pcs
O	Allen Wrench		1pc
	Touch up Pen		1pc

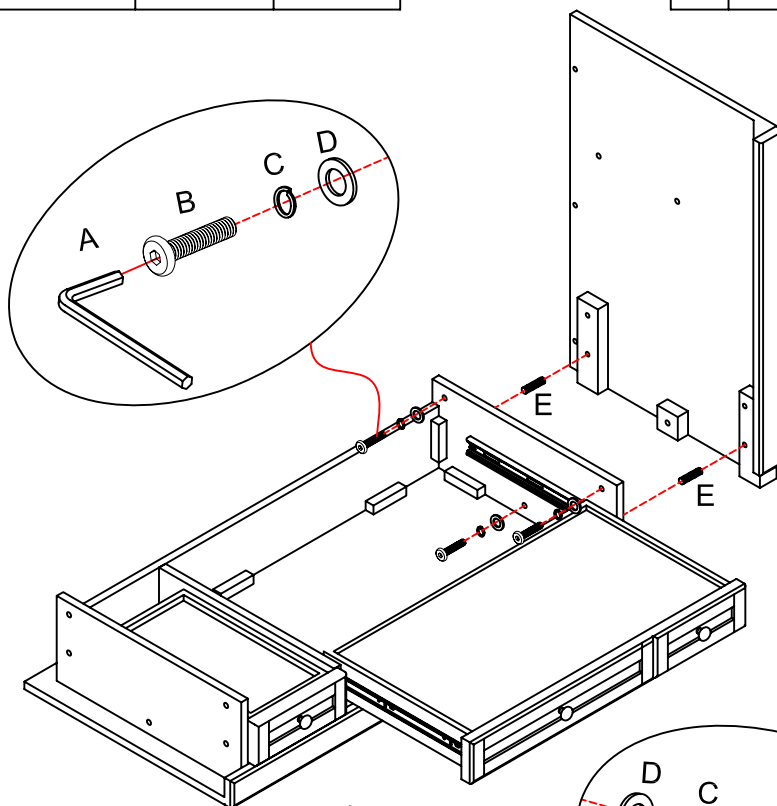

Step 1: Place Desk Top face down on soft surface. Attach Left Side Panel using Bolts (B), Lock Washers (C), & Flat Washers (D) securely to Desk Top with Allen Wrench (A) as shown in the illustration to the left.

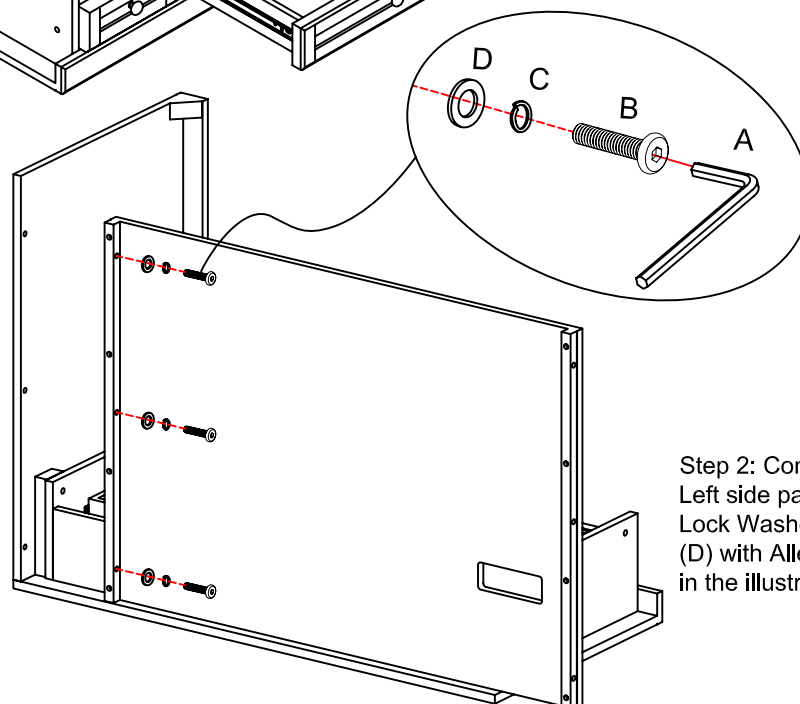

Step 2: Connect Back Panel and Left side panel by using Bolts (B), Lock Washers (C), & Flat Washers (D) with Allen Wrench (A) as shown in the illustration to the left.

Assembly Instruction

Item NO: CAT#461D

4/5

Repeat step 1 and step 2 to attach right side panel to desk top and back panel

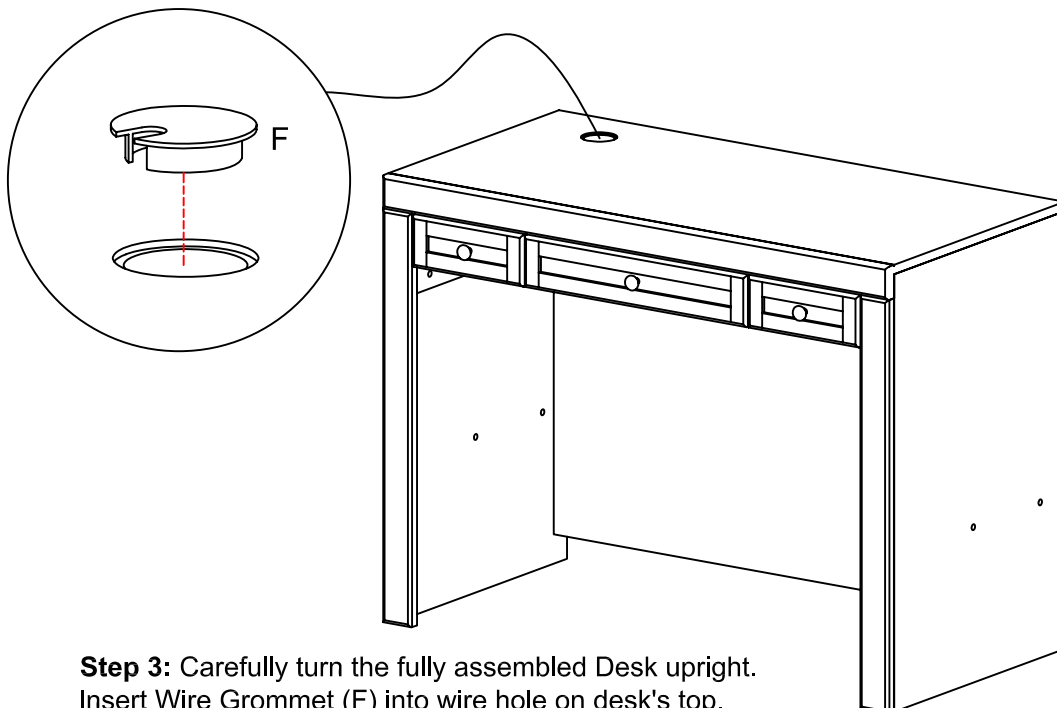
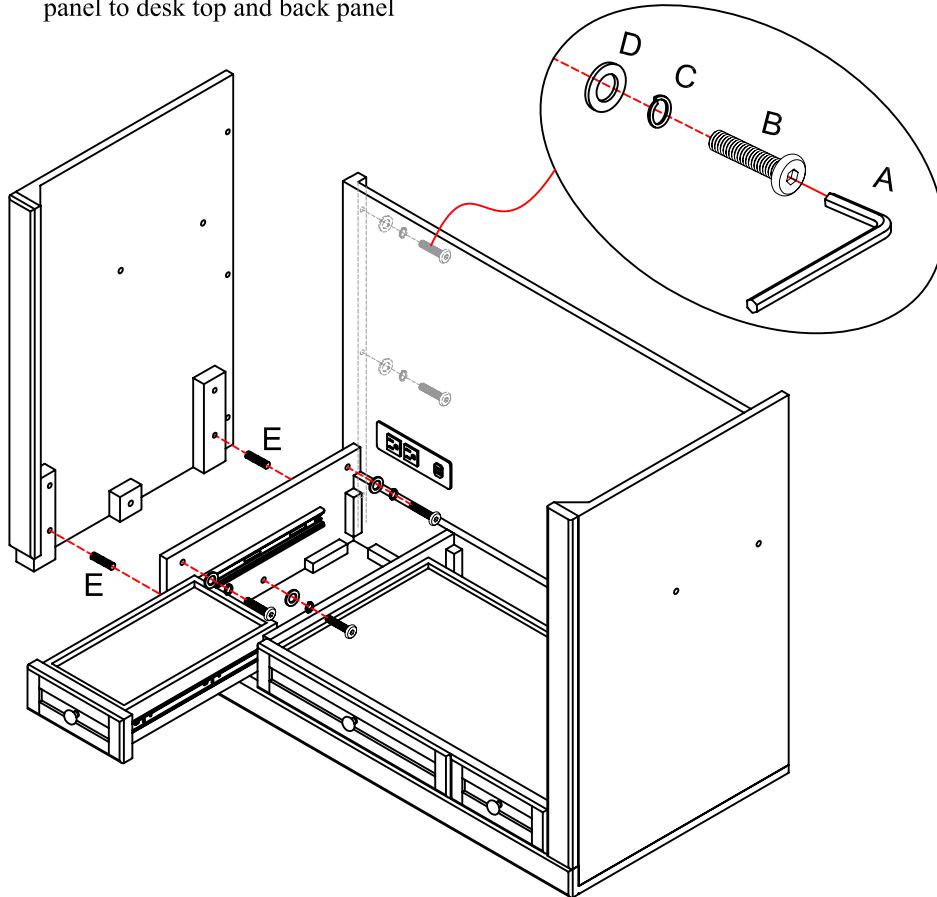

Step 3: Carefully turn the fully assembled Desk upright. Insert Wire Grommet (F) into wire hole on desk's top.

Assembly Instruction

Item NO: CAT#461D

5/5

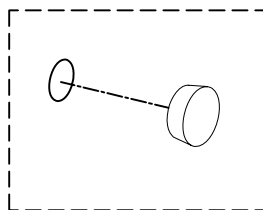
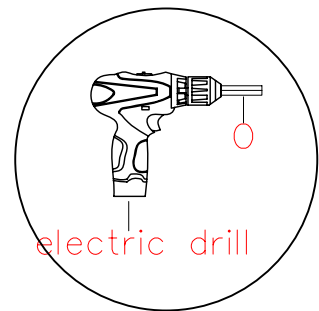
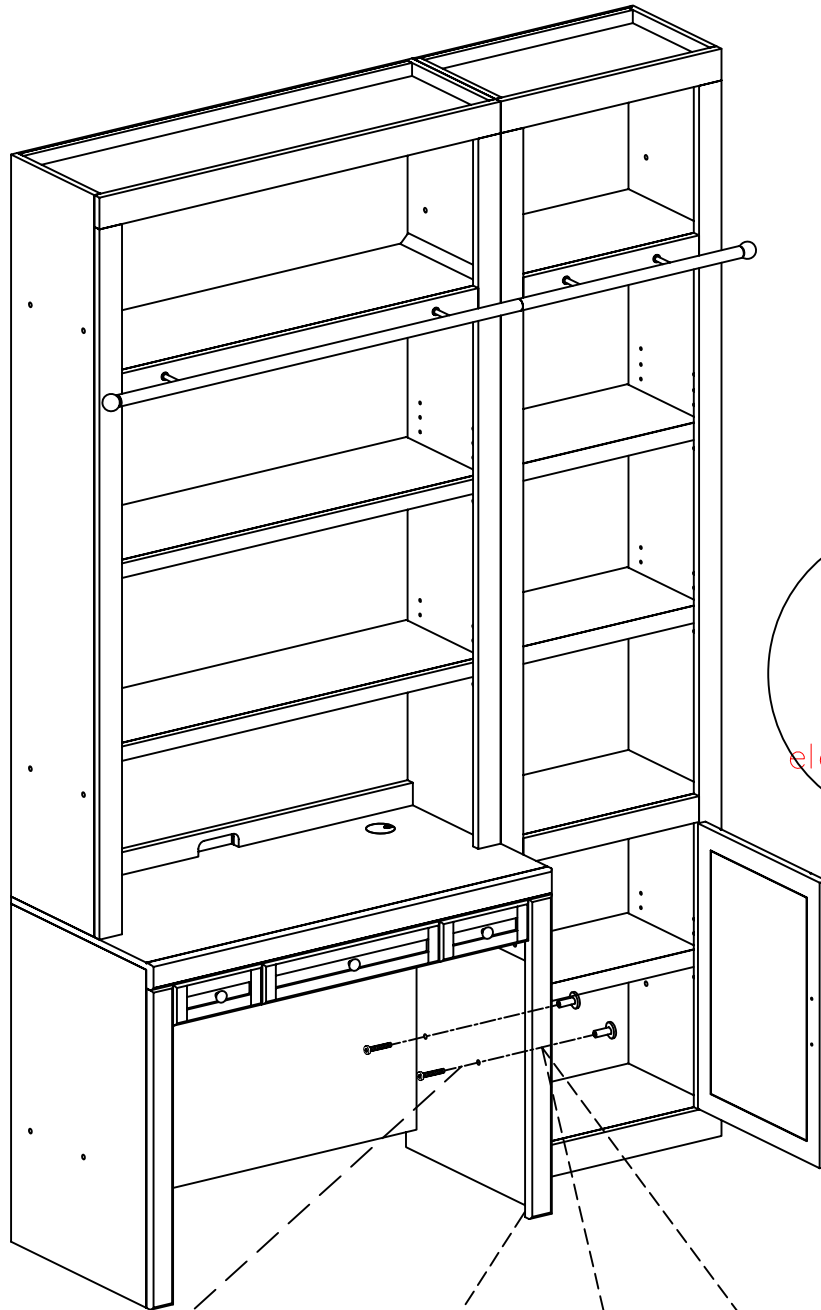

Remove the wood plugs before connecting the cabinets together.

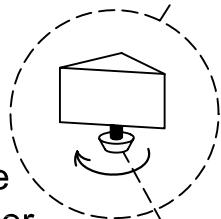

Levelers

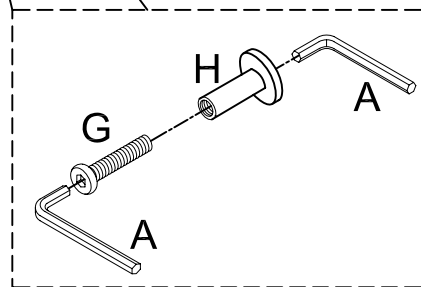

Align and connect cabinets with Connector Bolt (G) and Connector Cap (H).