

bed  
Bett  
Lit

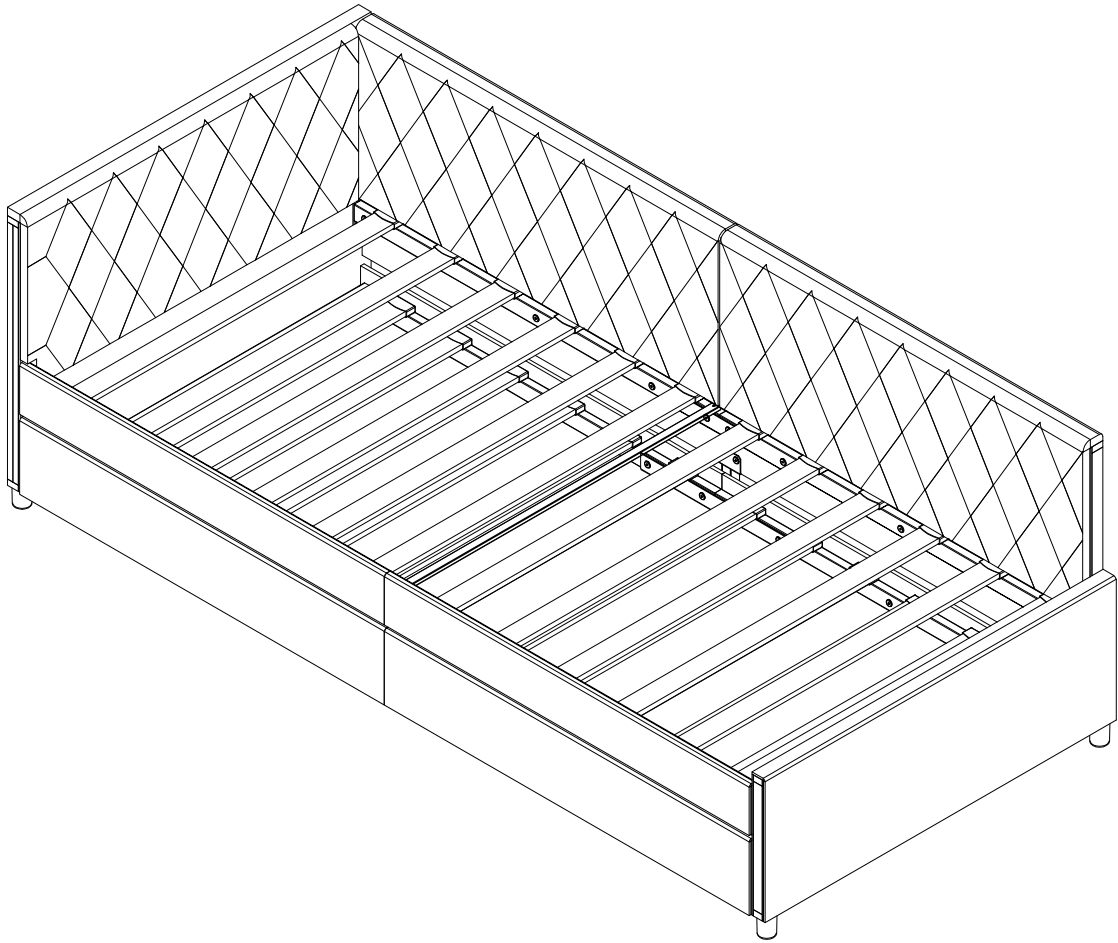

## Freundlicher Kundenservice

Zufriedenheitsgarantien: Bei Problemen mit der Montage, der Qualität oder der Rückgabe können Sie sich gerne direkt an uns wenden.

## Service client amical

Garanties de satisfaction : si vous rencontrez des problèmes d'assemblage, de qualité ou de retour, n'hésitez pas à nous contacter directement.

## Friendly customer Service

Satisfaction guarantee: if you have any problems with assembly, quality or feedback, please feel free to contact us directly.

# IMPORTANT/WICHTIG/ATENCION

## IMPORTANT/IMPORTANTE



EN-We recommend 2 or more people to install.  
DE-Wir empfehlen, dass die Montage von 2 oder mehreren Personen durchgeführt werden sollte.  
ES-Recomendamos realizar el ensamble con 2 o más personas.  
FR -Il est recommandé d'effectuer le montage à 2 personne(s) ou plus.  
IT -È necessaria la presenza di 2 o più persone per il montaggio di questo prodotto.



EN-The expected assembly time is 1 h.  
DE-Die Montagezeit beträgt durchschnittlich 1 h.  
ES-El tiempo aproximado de ensamble es de 1 h.  
FR-Le temps nécessaire est estimé à 1 h.  
IT-Il tempo previsto per il corretto assemblaggio è di 1 h.

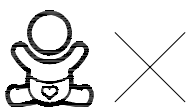

EN-Not intended for use by children.  
DE-Nicht geeignet für Kinder.  
ES-Producto no apto para niños.  
FR -Produit non destiné à être utilisé par des enfants.  
IT - Questo prodotto non è destinato all'uso da parte dei bambini.



EN-Keep away from fire or other heat sources.  
DE-Bitte von Feuer und Hitzequellen fernhalten.  
ES -Manténgase alejado de las llamas y otras fuentes de calor.  
FR -Tenir à distance des flammes et autres sources de chaleur.  
IT -Tenere lontano dal fuoco o da altre fonti di calore.

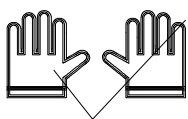





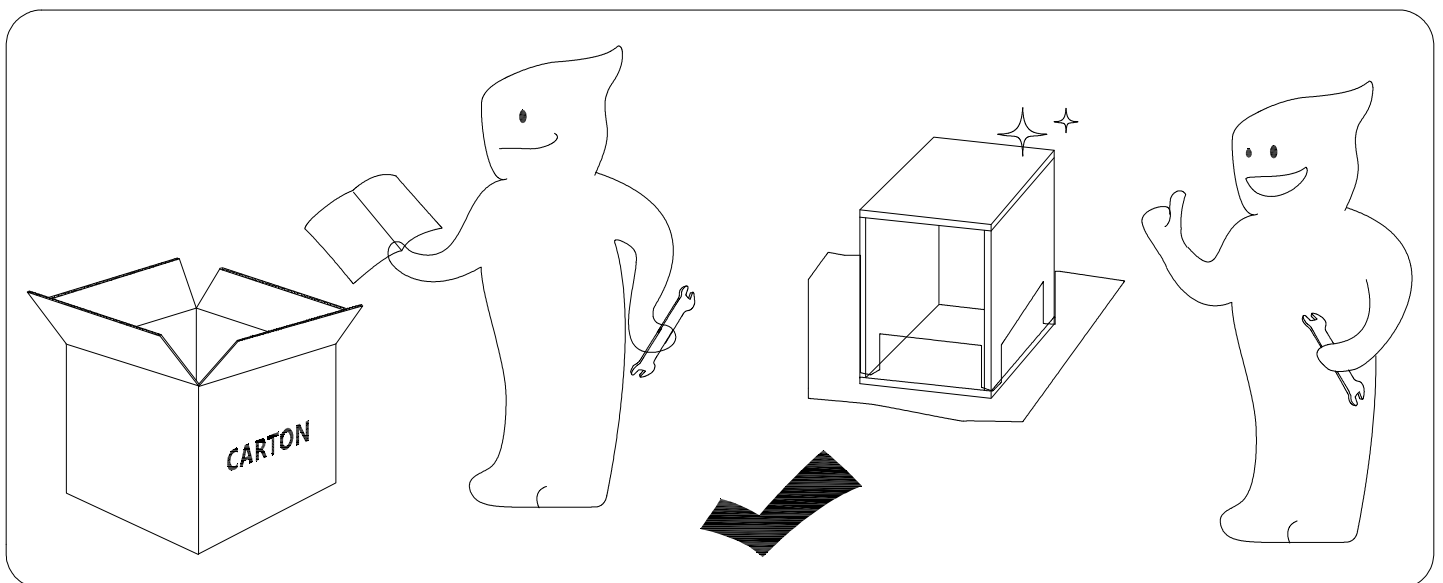
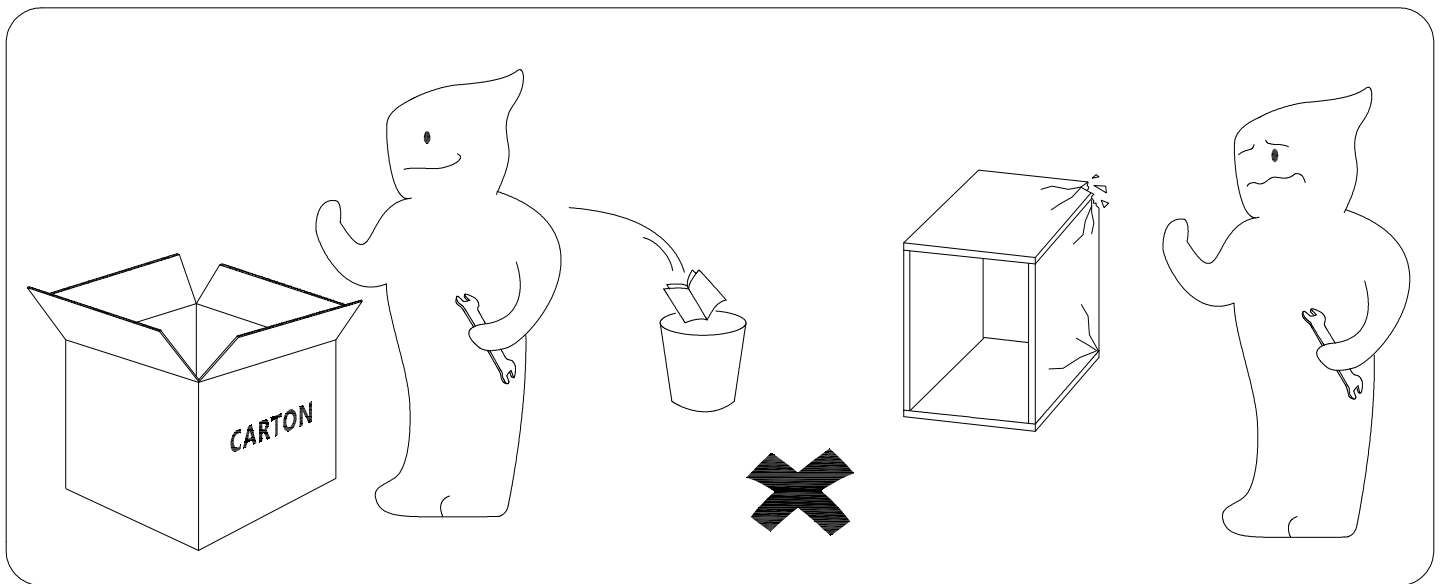

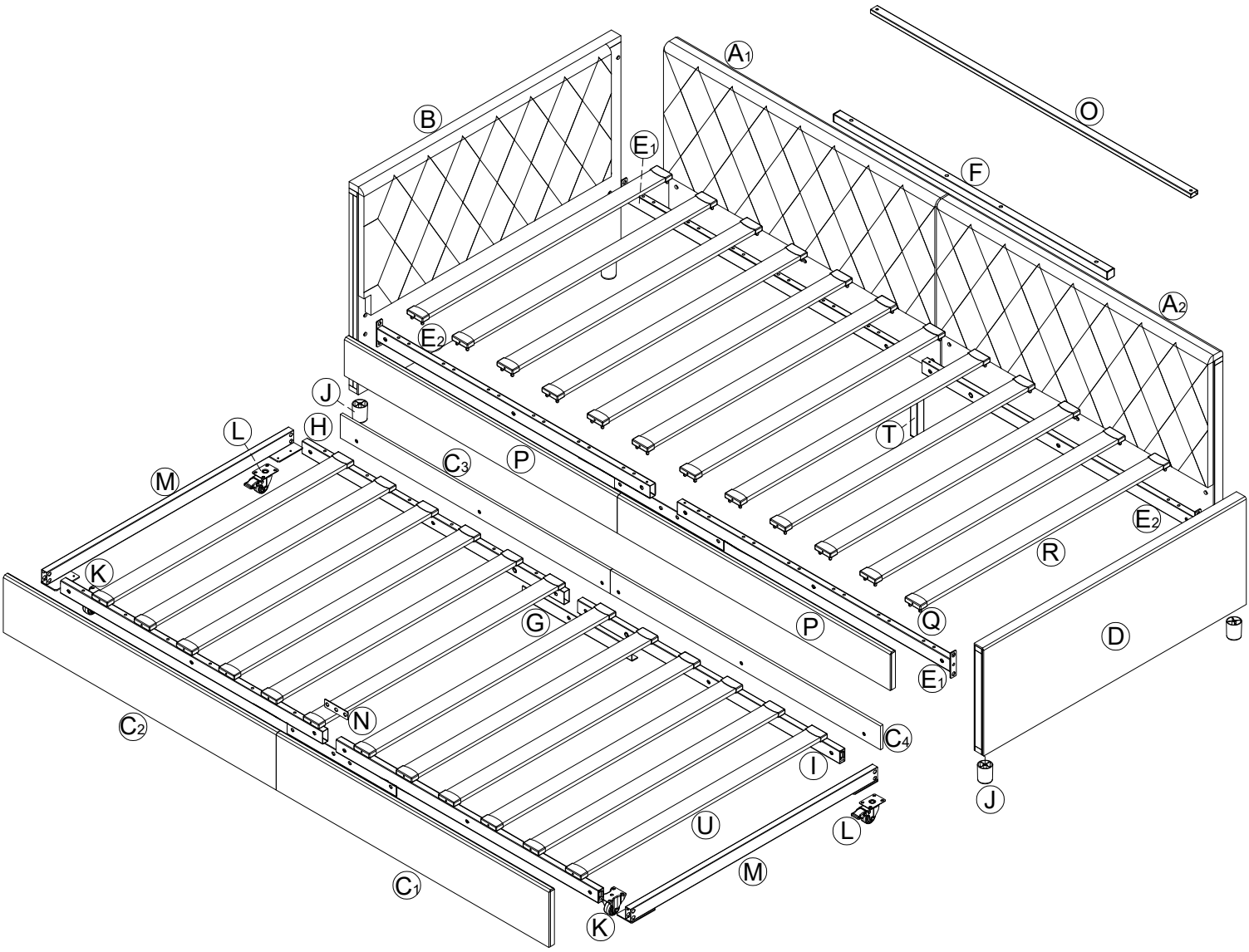



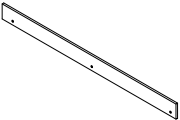
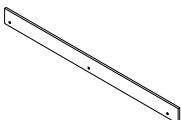
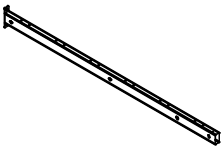
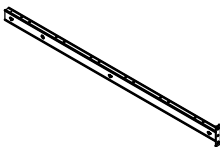
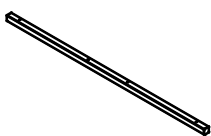
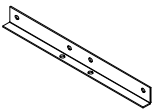
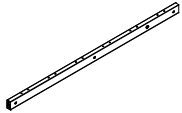
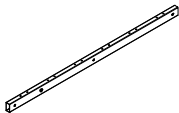

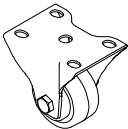
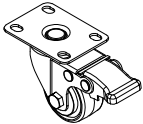
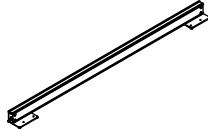
EN-We recommend wearing protective gloves.  
DE-Wir empfehlen das Tragen von Schutzhandschuhen.  
ES-Recomendamos el uso de guantes de seguridad.  
FR-Il est recommandé de porter des gants de protection.  
IT-Per il processo di assemblaggio, consigliamo fortemente l'utilizzo di guanti protettivi.

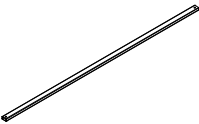
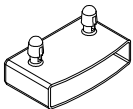
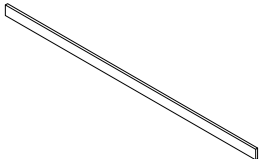
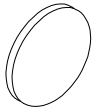
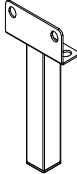
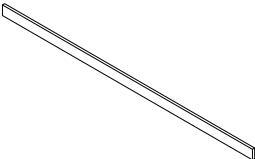
EN - Please follow the instruction manuals and use a pad to avoid damage during assembly.  
DE - Bitte folgen Sie der Anleitung und verwenden Sie eine Unterlage, um Beschädigungen bei der Montage zu vermeiden.  
ES - Por favor, siga las instrucciones del manual y utilice una cubierta o lona para proteger el producto y el suelo durante la instalación.  
FR - Suivez les instructions de la notice et utilisez une couverture ou une bache pour protéger le produit et les sols pendant le montage.  
IT - Si prega di consultare il manuale illustrativo durante il montaggio e di utilizzare un cuscinetto per evitare possibili danni.



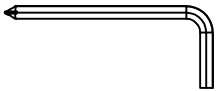

LISTE DER EINZELTEILE  
 LISTE D'OBJETS  
 PARTS LIST  
 PAKET 1/FORFAIT 1/PACKAGE 1

<b>C<sub>3</sub></b>  1PCS	<b>C<sub>4</sub></b>  1PCS	<b>E<sub>1</sub></b>  2PCS	<b>E<sub>2</sub></b>  2PCS	<b>F</b>  1PCS
<b>G</b>  3PCS	<b>H</b>  2PCS	<b>I</b>  2PCS	<b>J</b>  4PCS	<b>K</b>  2PCS
<b>L</b>  2PCS	<b>M</b>  2PCS	<b>N</b>  1PCS	<b>O</b>  1PCS	<b>Q</b>  48PCS
<b>R</b>  12PCS	<b>S</b>  4PCS	<b>T</b>  1PCS	<b>U</b>  12PCS	<b>1</b>  M8*35 28PCS
<b>2</b>  M6*30 4PCS	<b>3</b>  M8*40 7PCS	<b>4</b>  M8*18 24PCS	<b>5</b>  M6*10 16PCS	<b>6</b>  4*80 1PCS
<b>7</b>  M8*30 4PCS	<b>8</b>  M5*35 2PCS	<b>9</b>  4*80 1PCS		

LISTE DER EINZELTEILE  
LISTE D'OBJETS  
PARTS LIST  
PAKET 2/FORFAIT 2/PACKAGE 2

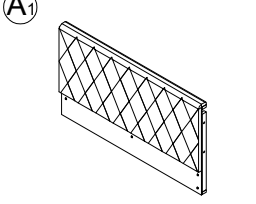
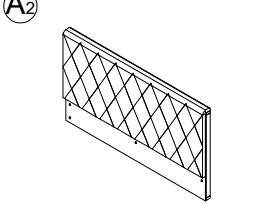
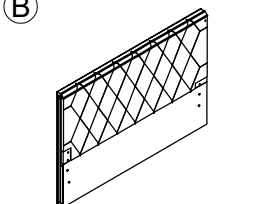
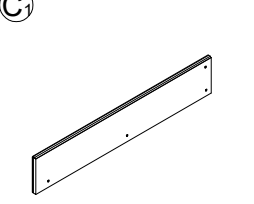
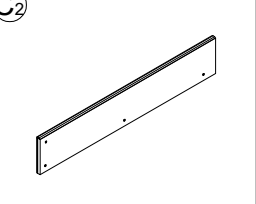
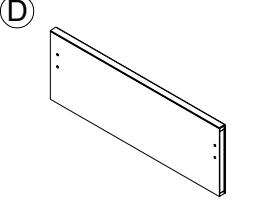
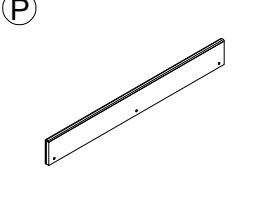
 <p>A1</p> <p>1PCS</p>	 <p>A2</p> <p>1PCS</p>	 <p>B</p> <p>1PCS</p>	 <p>C1</p> <p>1PCS</p>	 <p>C2</p> <p>1PCS</p>
 <p>D</p> <p>1PCS</p>	 <p>P</p> <p>2PCS</p>			

1

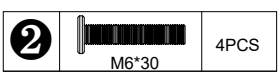
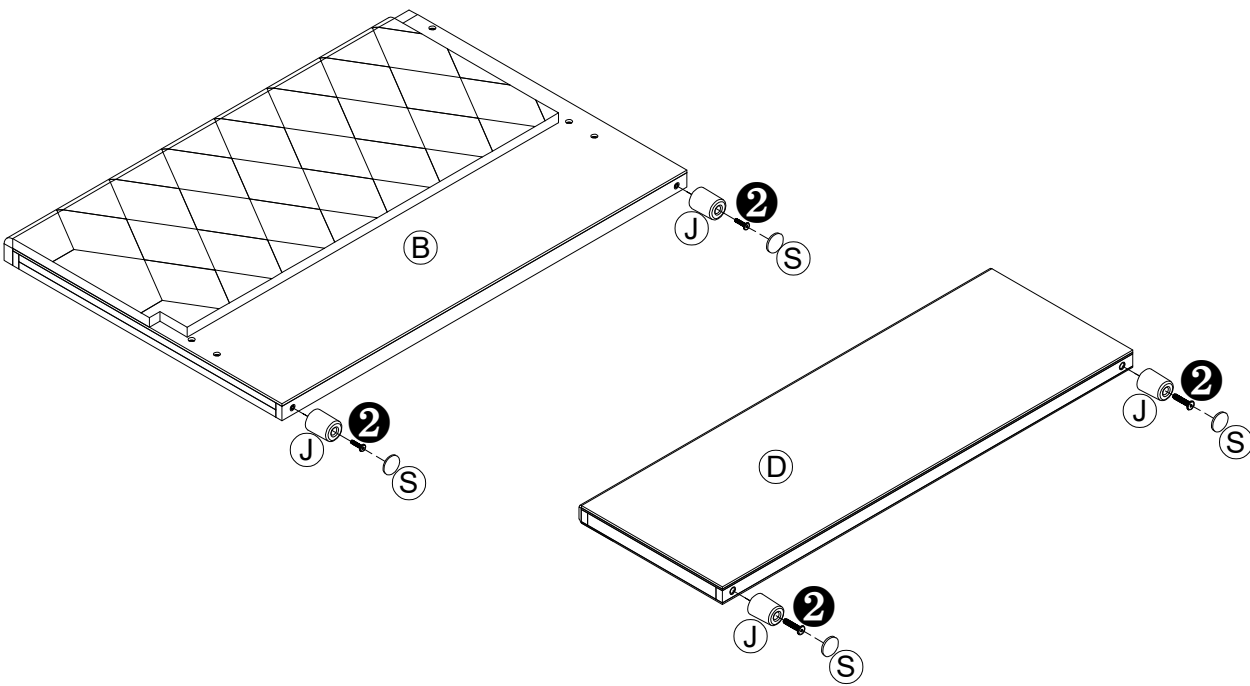

2

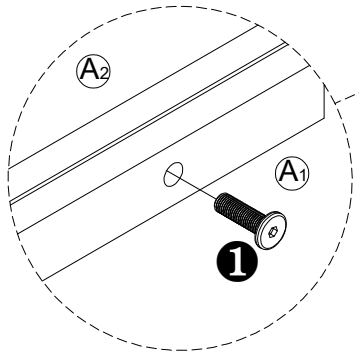
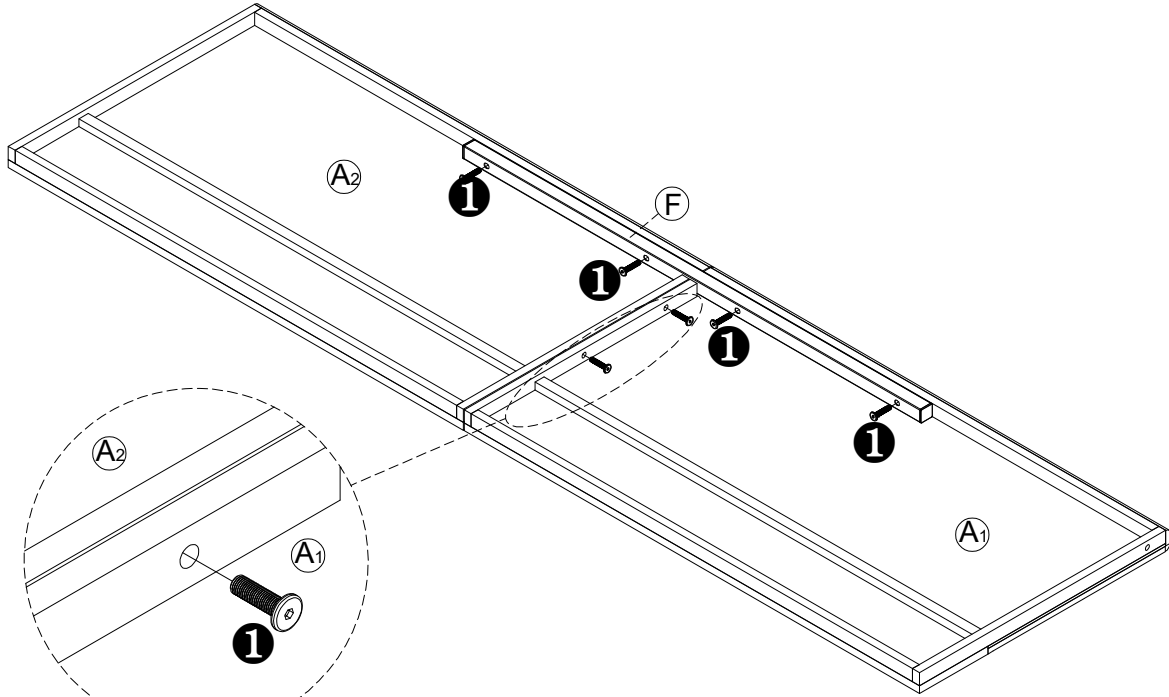

3

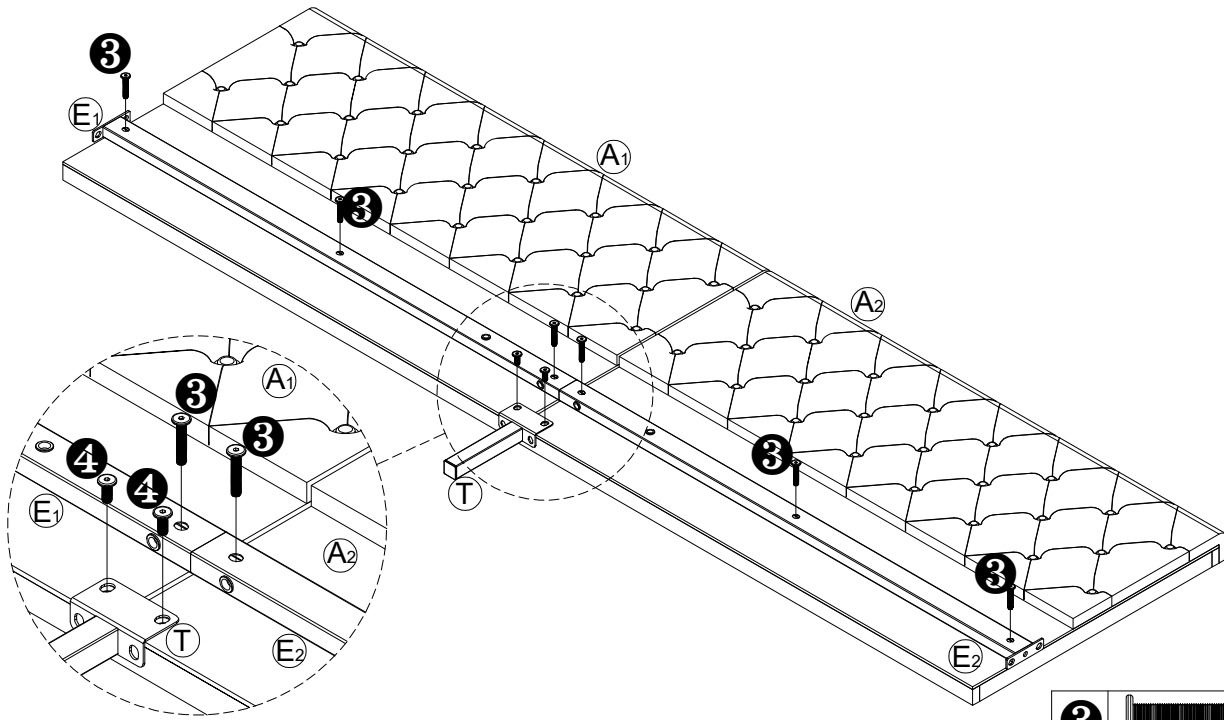

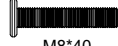
<b>3</b>		6PCS
	M8*40	
<b>4</b>		2PCS
	M8*18	

4

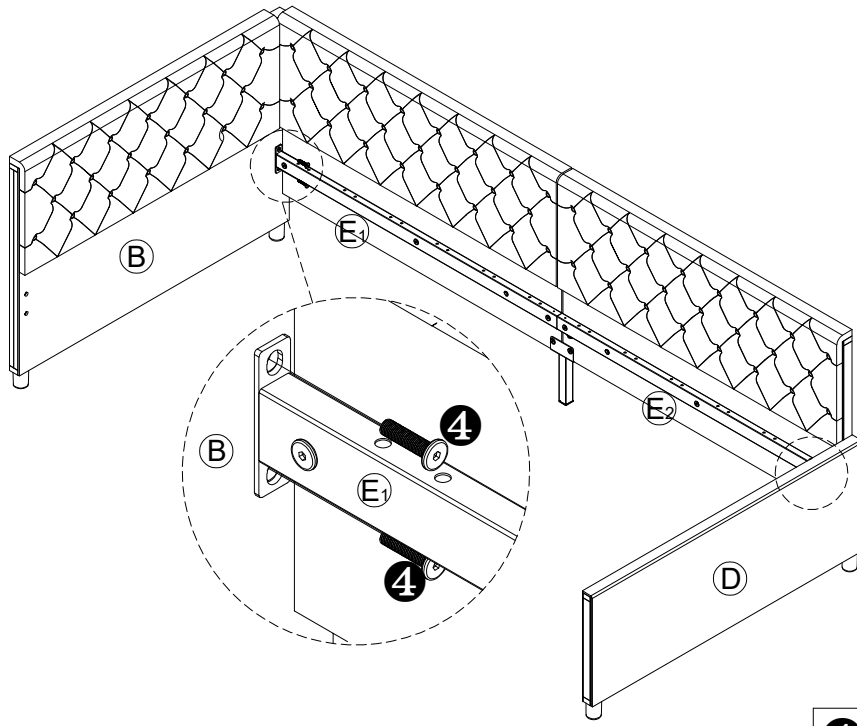

<b>4</b>		4PCS
	M8*18	

5

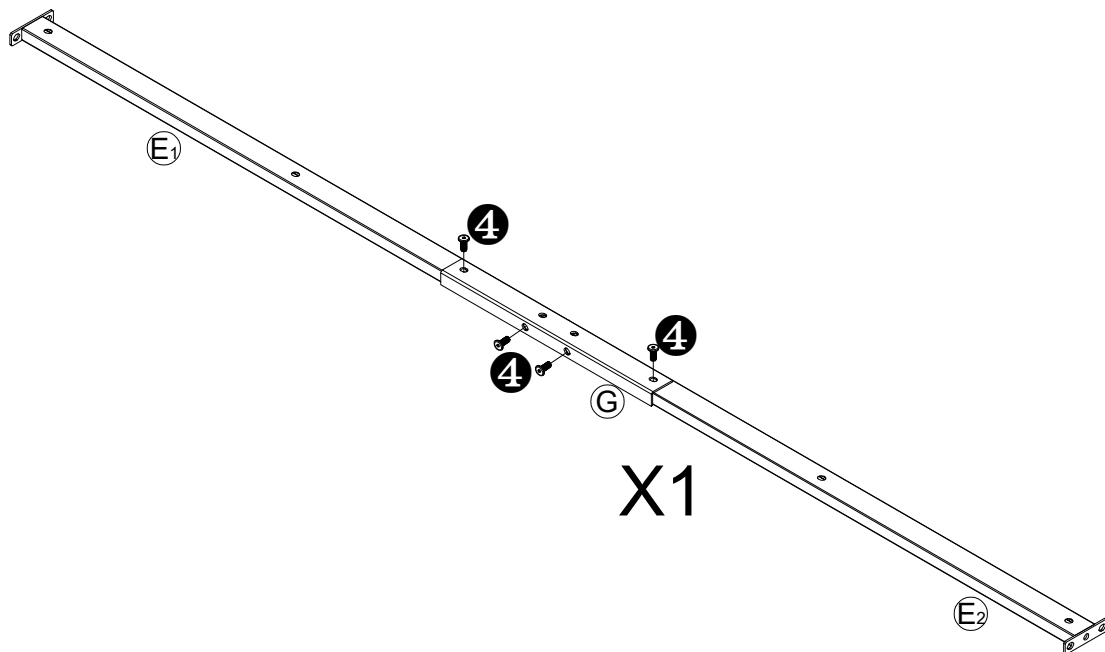

<b>4</b>	 M8*18	4PCS
----------	--	------

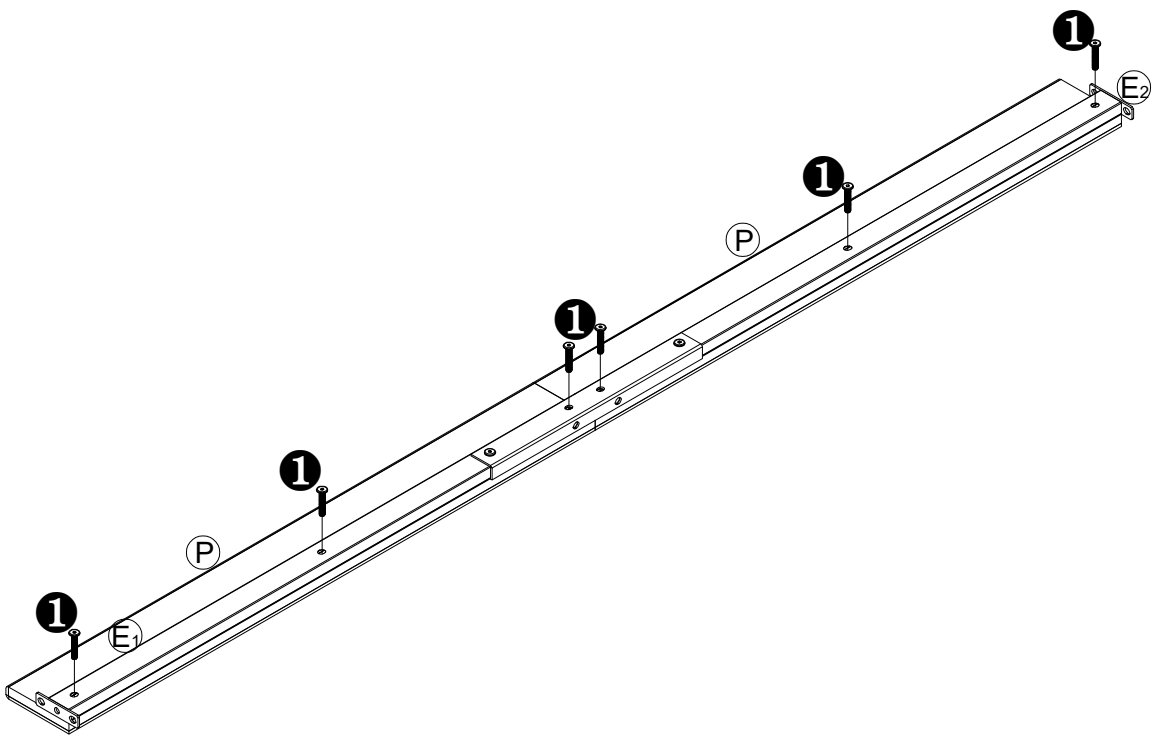

6

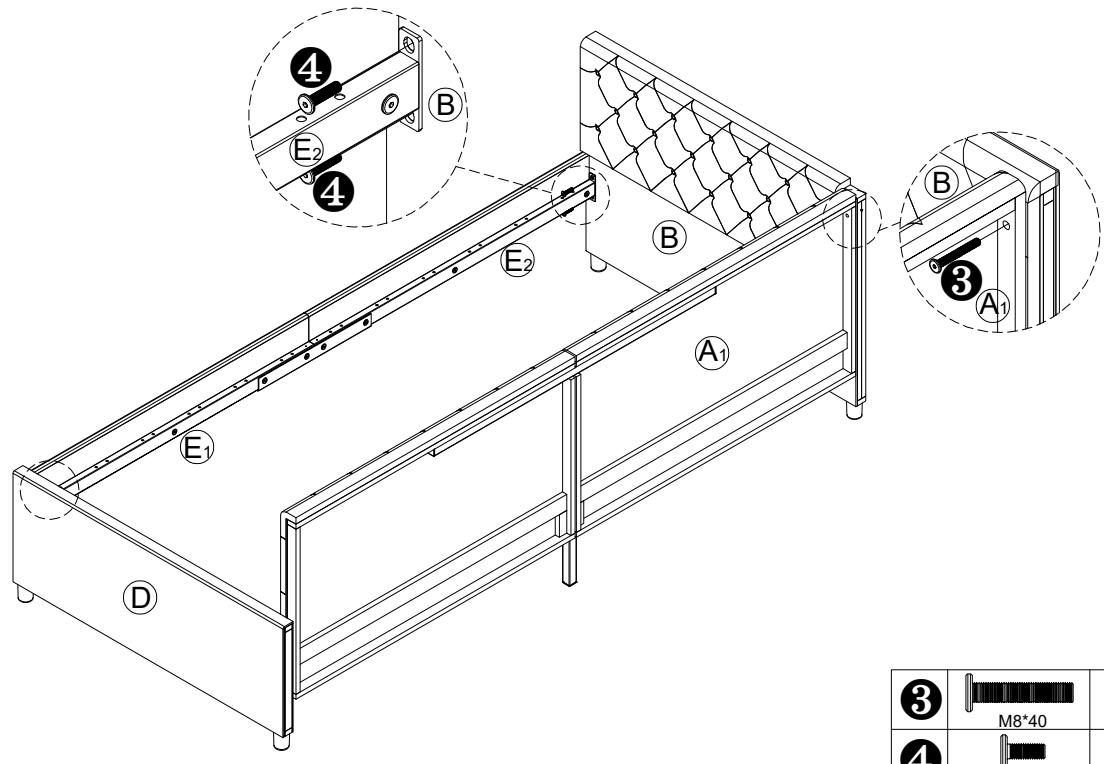

<b>1</b>	 M8*35	6PCS
----------	--	------

7



<b>3</b>		M8*40	1PC
<b>4</b>		M8*18	4PCS

8

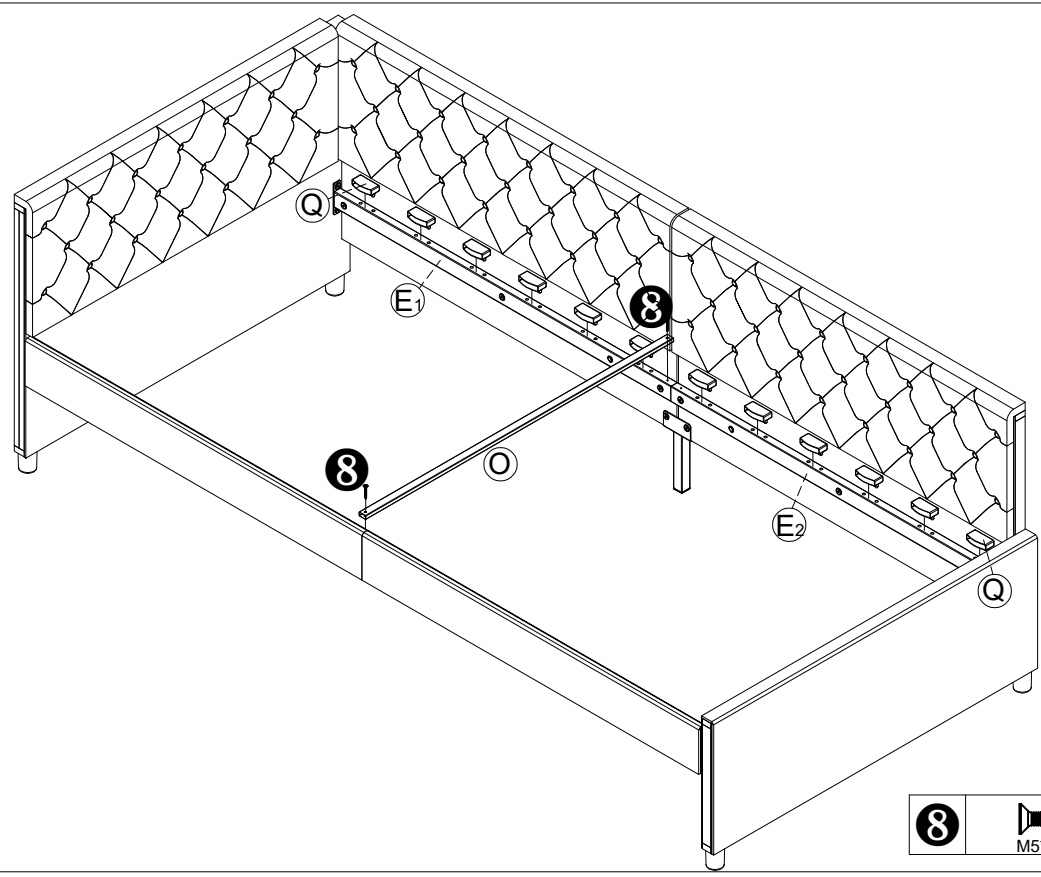

<b>8</b>		M5*35	2PCS
----------	---	-------	------

9

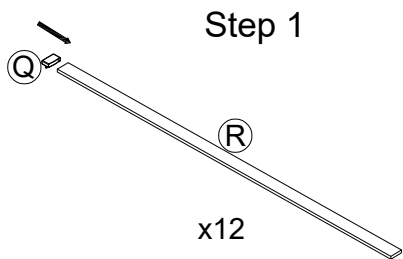

Step 1

x12

Step 2

Step 3

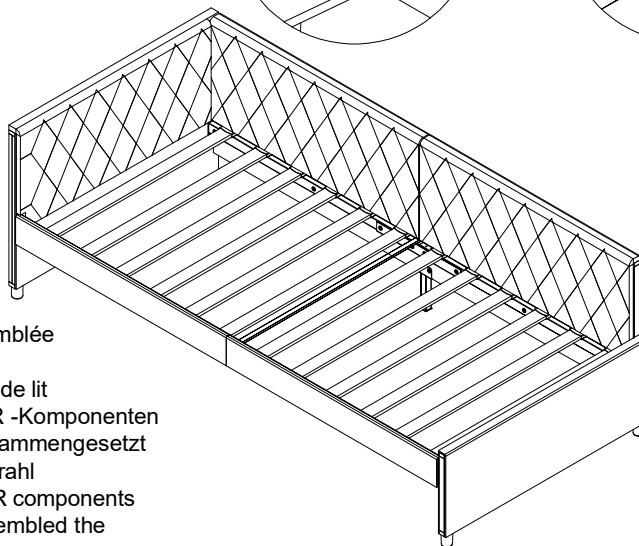
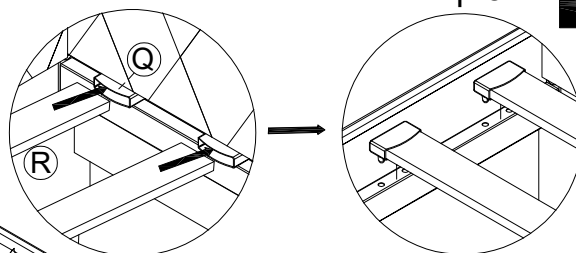

Insérez d'abord une extrémité qui n'est pas assemblée dans les composants R dans les composants Q assemblés, puis assemblé l'autre sur le faisceau de lit  
 Fügen Sie zuerst ein Ende ein, das nicht in den R -Komponenten in die zusammengesetzten Q -Komponenten zusammengesetzt ist, und montiert dann das andere auf dem Bettstrahl  
 First insert one end that is not assembled in the R components into the assembled Q components, and then assembled the other on the bed beam

10

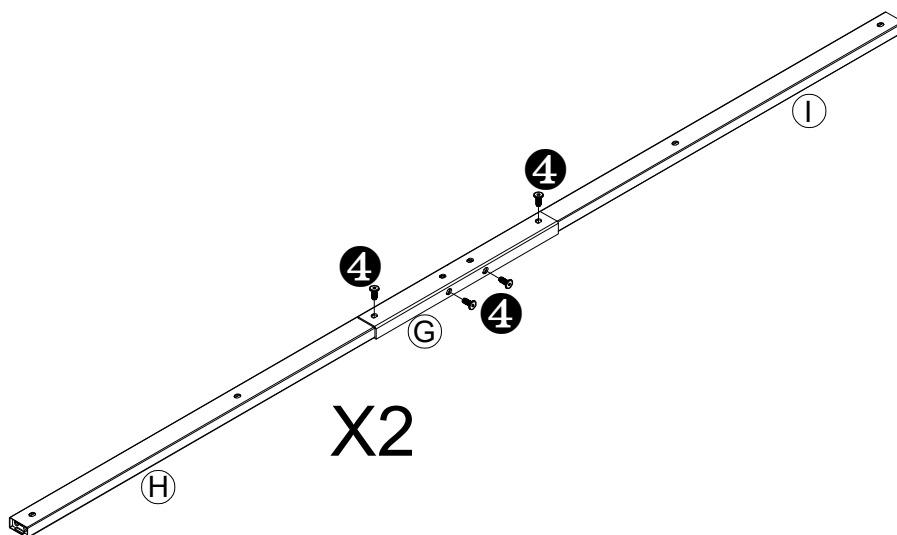

X2



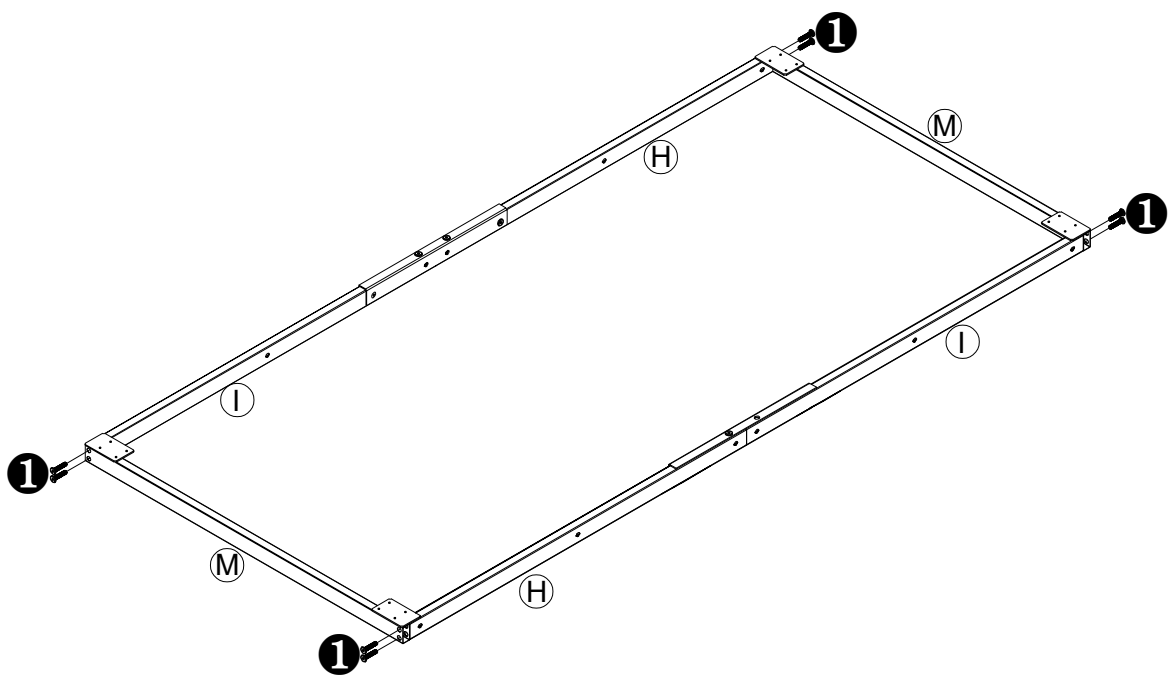

11



<b>1</b>		8PCS
M8*35		

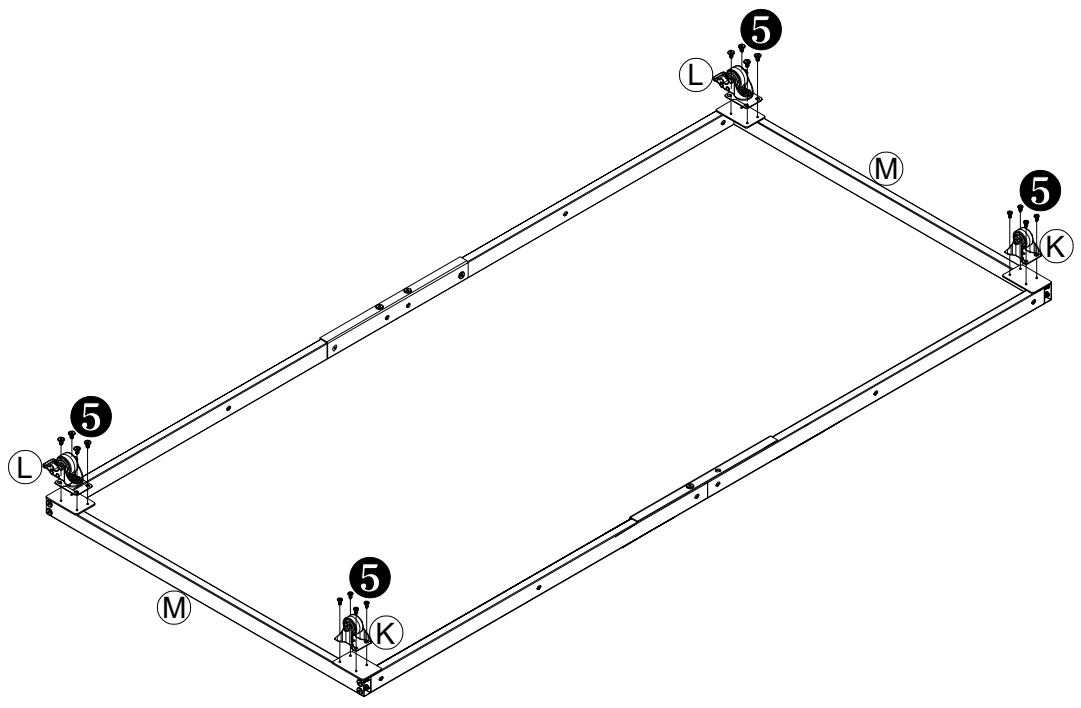

12

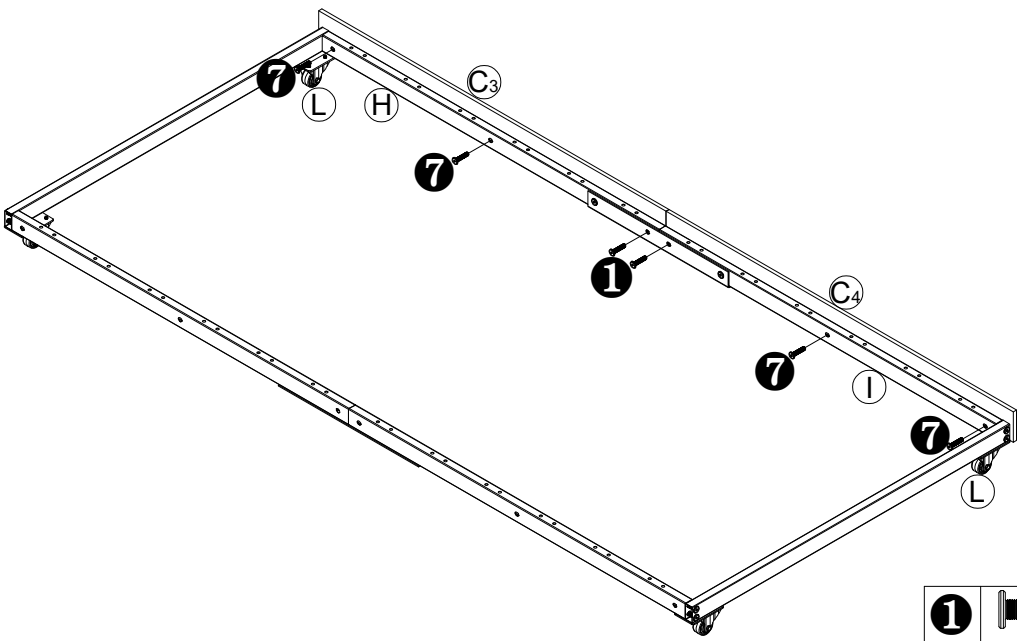

<b>5</b>		16PCS
M6*10		

13



<b>1</b>		2PCS
	M8*35	
<b>7</b>		4PCS
	M8*30	

14

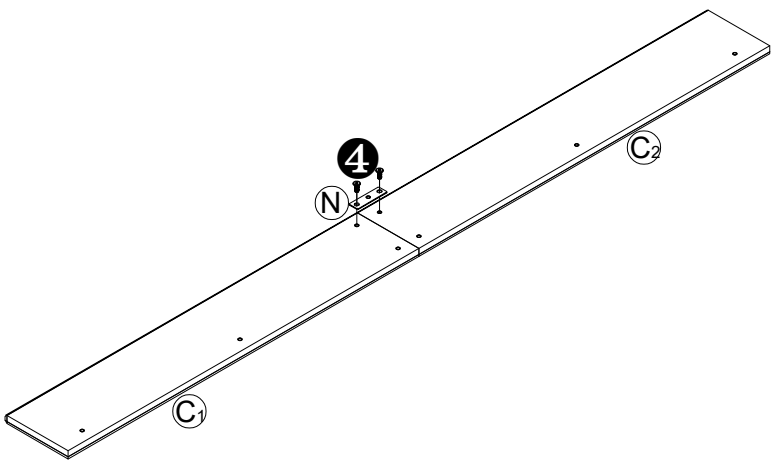

<b>4</b>		2PCS
	M8*18	

15

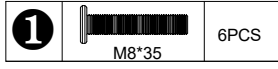
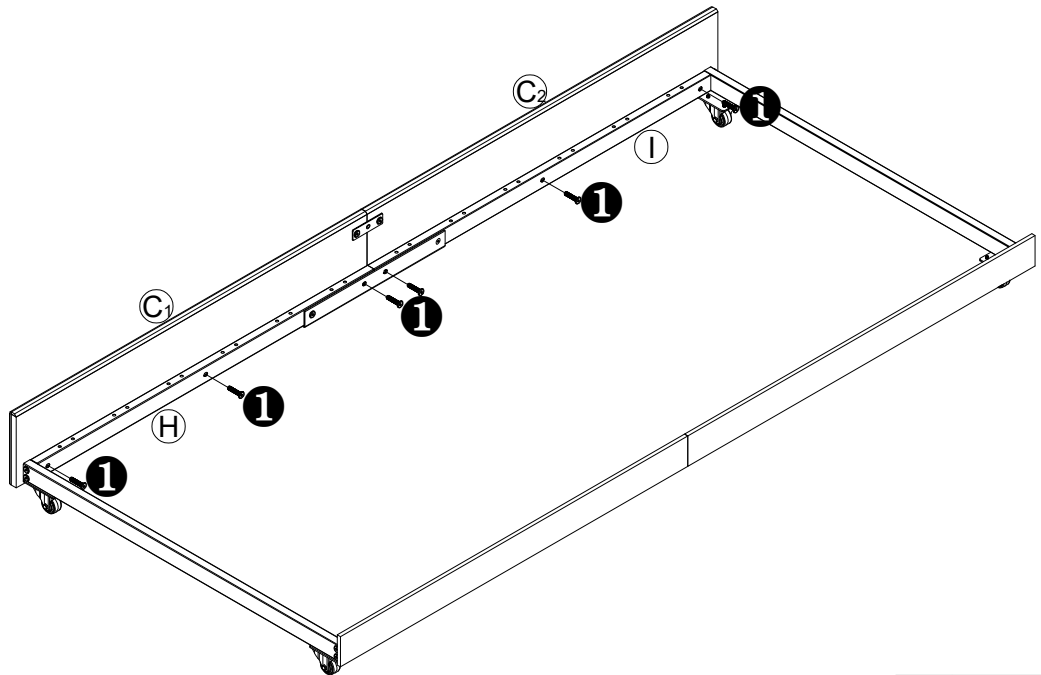

16

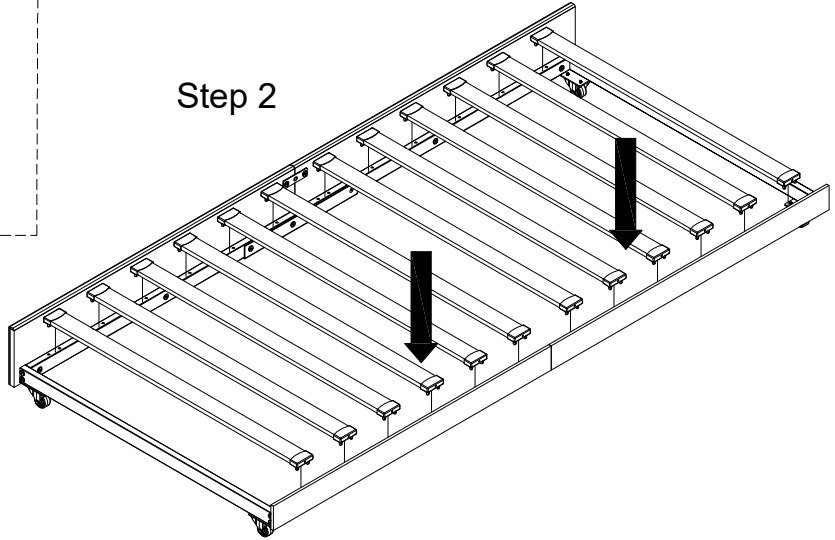
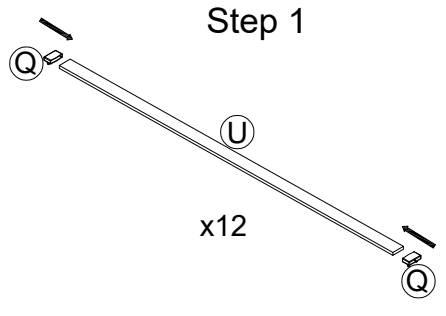

**Finished Product**  
**Fertiges Produkt**  
**Produit Fini**

