

-93526

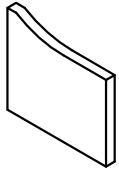

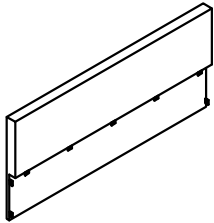
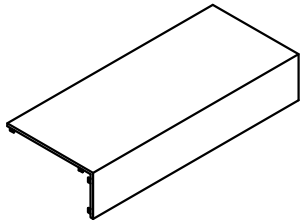

ASSEMBLY INSTRUCTIONS

-93526

PART LIST

1		x2
2		x1
3		x1

HARDWARE LIST

NO.	DESCRIPTION	SKETCH	Q.TY
A	Batt		2
B	Allen Bolt M6x20		21
C	Flat Washer M6		21
D	Allen Wrench M4		1

STEP 1

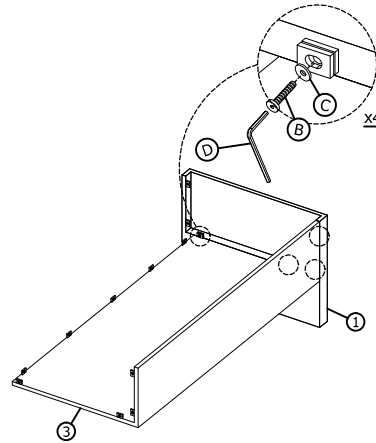

STEP 2

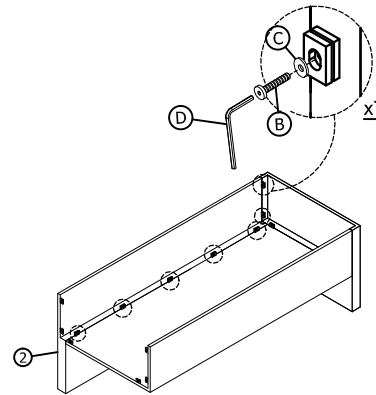

STEP 3

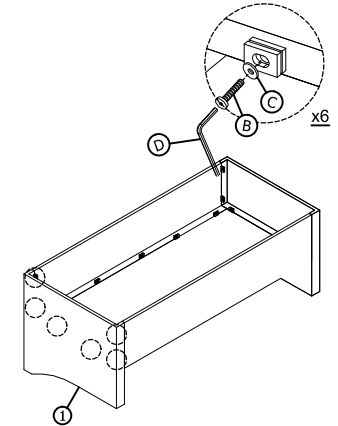

STEP 4

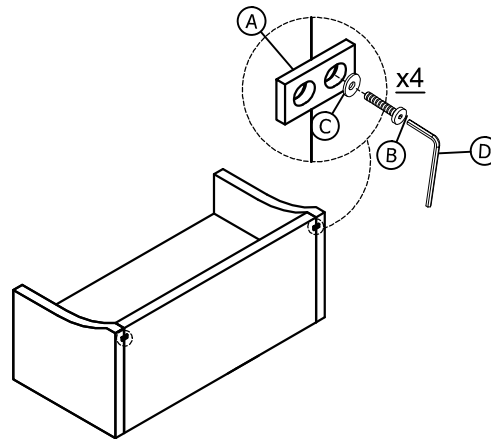

STEP 5

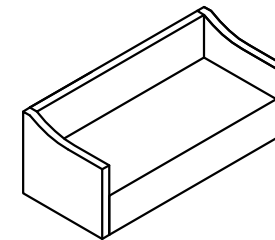

IMPORTANT NOTE:

Put the screws into the hole, then use the allen wrench make loose, not too tight-Then, all of the screws are all the correct holes, tight the screws. Do not make too tight the screws from hole by hole.

Thank you.