

# **DINING TABLE**

## **ASSEMBLY INSTRUCTIONS**



# ASSEMBLY INSTRUCTIONS

**ASSEMBLY TIPS:**

1. Remove hardware from box and sort by size.
2. Please check to see that all hardware and parts are present prior to start of assembly.
3. Please follow attached instructions in the same sequence as numbered to assure fast & easy assembly.

**Warning!**





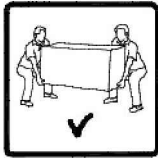

1. Don't attempt to repair or modify parts that are broken or defective. Please contact the store immediately.
2. This product is for home use only and not intended for commercial establishments.

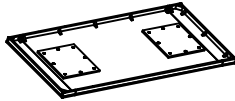

**ASSEMBLY TIME**

**10 MINUTES**

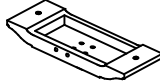
## PARTS IDENTIFICATION

	PART NAME	FIGURE	QTY
<b>A</b>	TOP		1 PC
<b>B</b>	LEAF		2 PCS
<b>C</b>	MOUNTING PLATE		2 PCS
<b>D</b>	BASE		2 PCS
<b>E</b>	CROSS BAR		1 PC

<b>F</b>	PEDESTAL COLUMN		2 PCS
----------	-----------------	--	-------

# ASSEMBLY INSTRUCTIONS

## ASSEMBLY TIPS:

1. Remove hardware from box and sort by size.
2. Please check to see that all hardware and parts are present prior to start of assembly.
3. Please follow attached instructions in the same sequence as numbered to assure fast & easy assembly.







### Warning!



1. Don't attempt to repair or modify parts that are broken or defective. Please contact the store immediately.
2. This product is for home use only and not intended for commercial establishments.

## HARDWARE IDENTIFICATION

( BOX 1 ) - HARDWARE PACK IS LOCATED

	HARDWARE NAME	FIGURE	QTY
1	LONG BOLT (5/16" x 45mm - BLK)		12 PCS
2	SHORT BOLT (5/16" x 38mm - BLK)		8 PCS
3	HEX NUT (5/16" x 12mm - BLK)		8 PCS
4	LOCK WASHER (5/16" x 12 x 1.1mm - BLK)		28 PCS
5	FLAT WASHER (5/16" x 22 x 2mm - BLK)		28 PCS
6	ALLEN WRENCH (4mm - BLK)		1 PC
7	WRENCH (12mm -BLK)		1 PC

# ASSEMBLY INSTRUCTIONS

## STEP 1

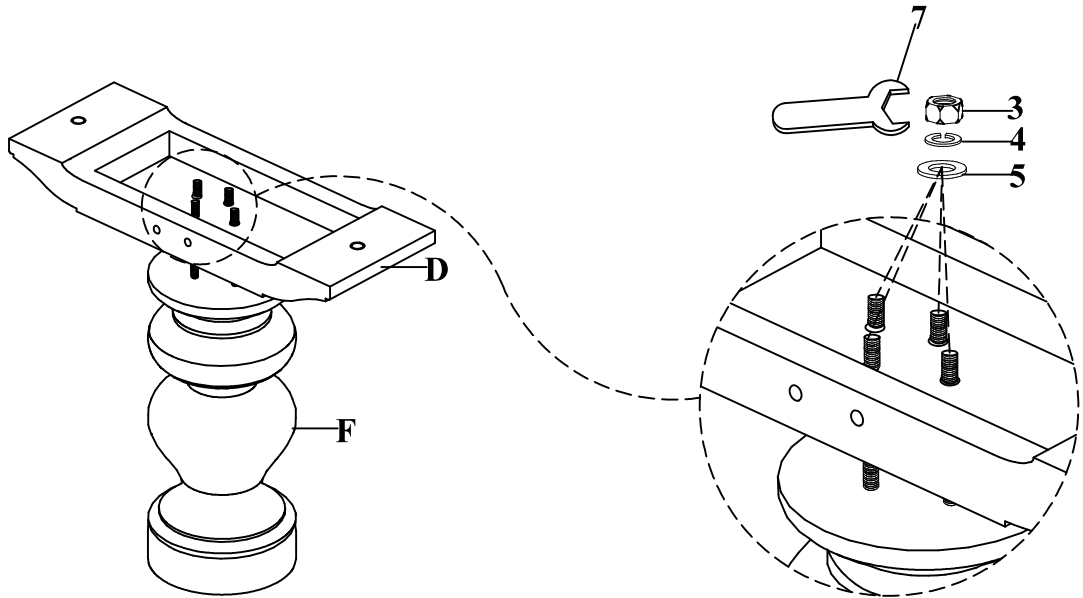

## STEP 2

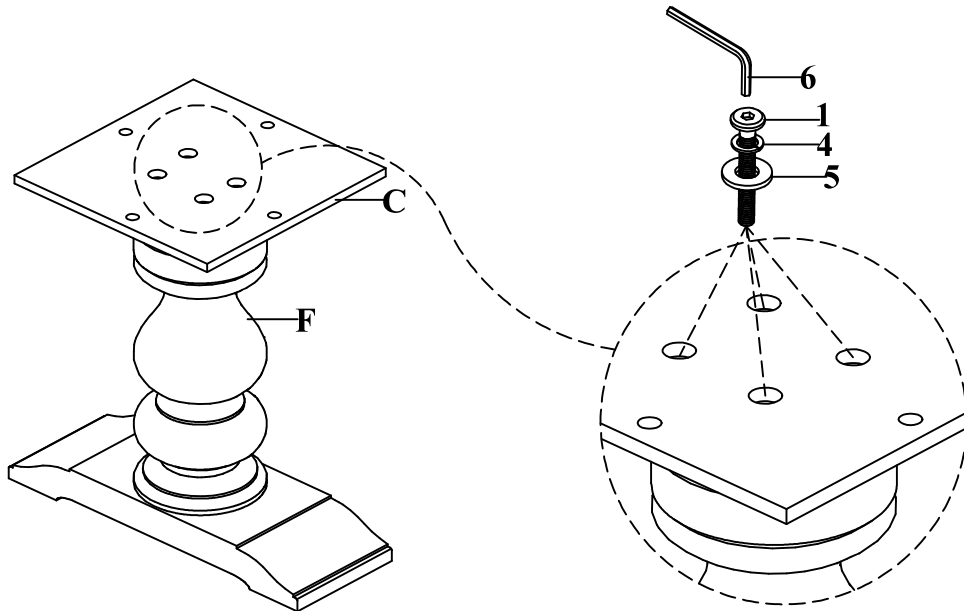

## STEP 3

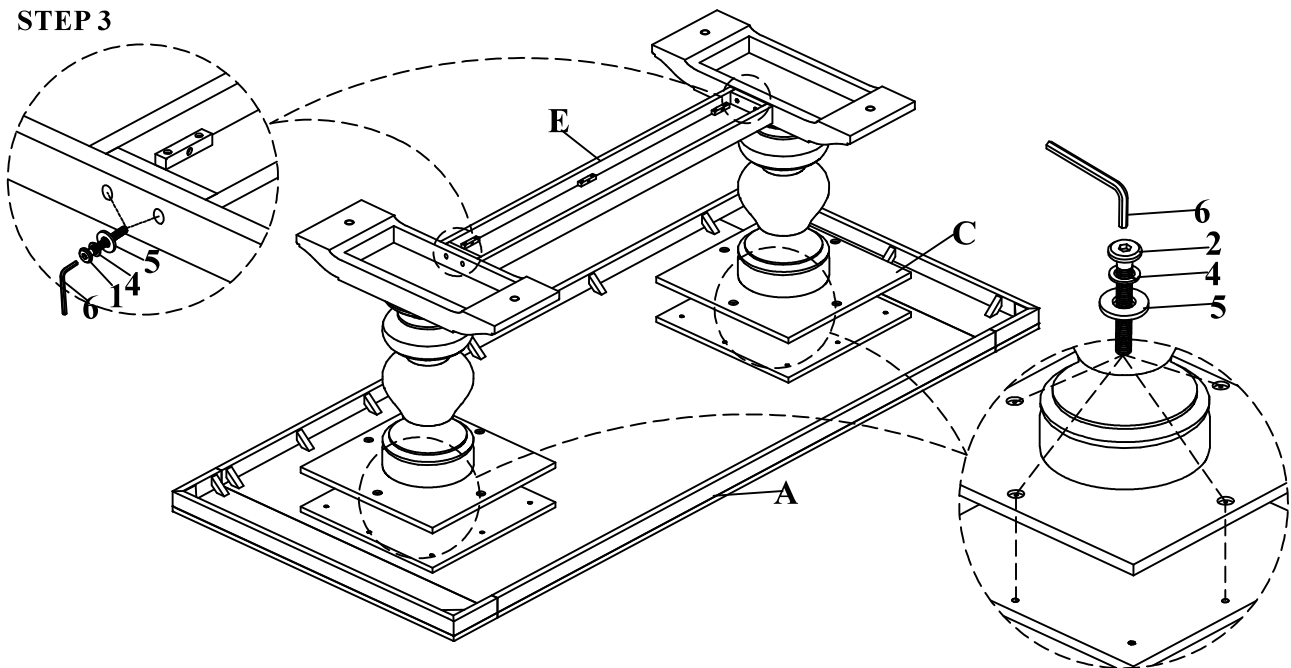

# ASSEMBLY INSTRUCTIONS

STEP 4

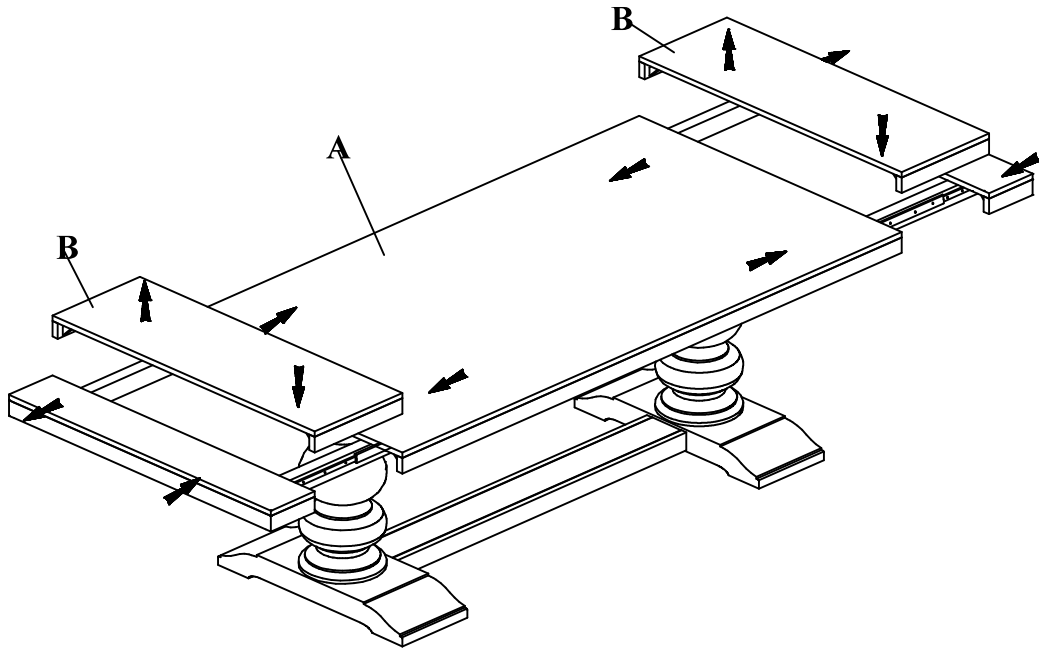

STEP 5

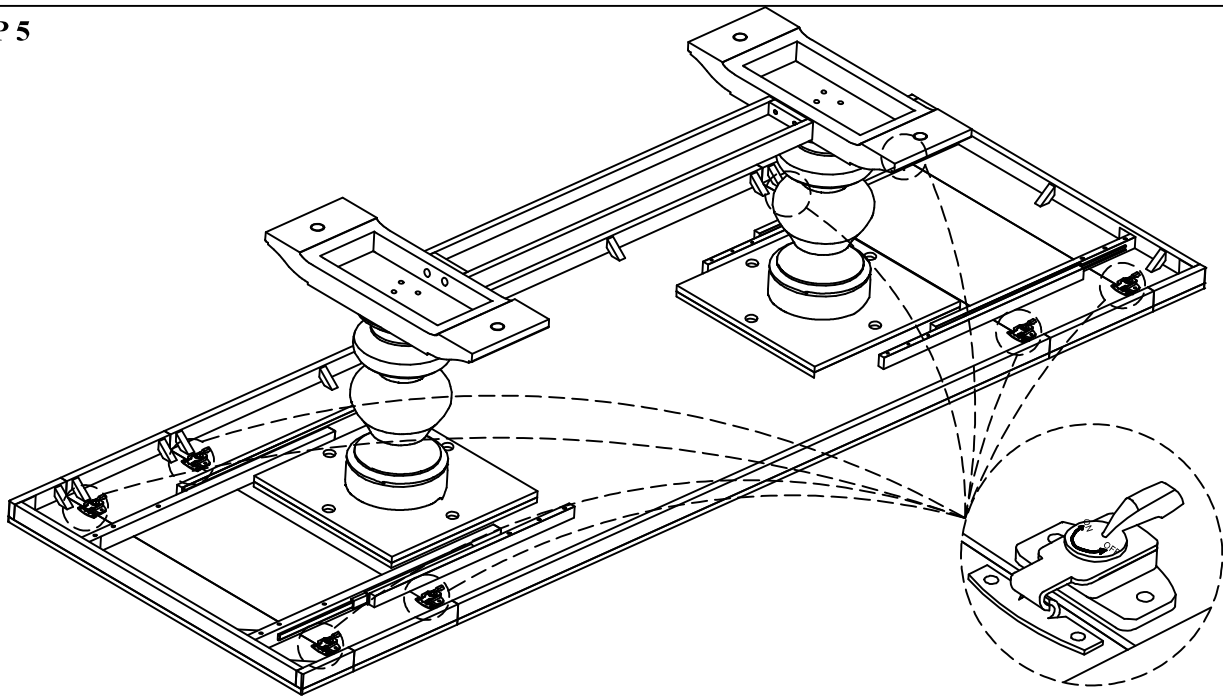

STEP 6

COMPLETE

