

INSTRUCTION MANUAL

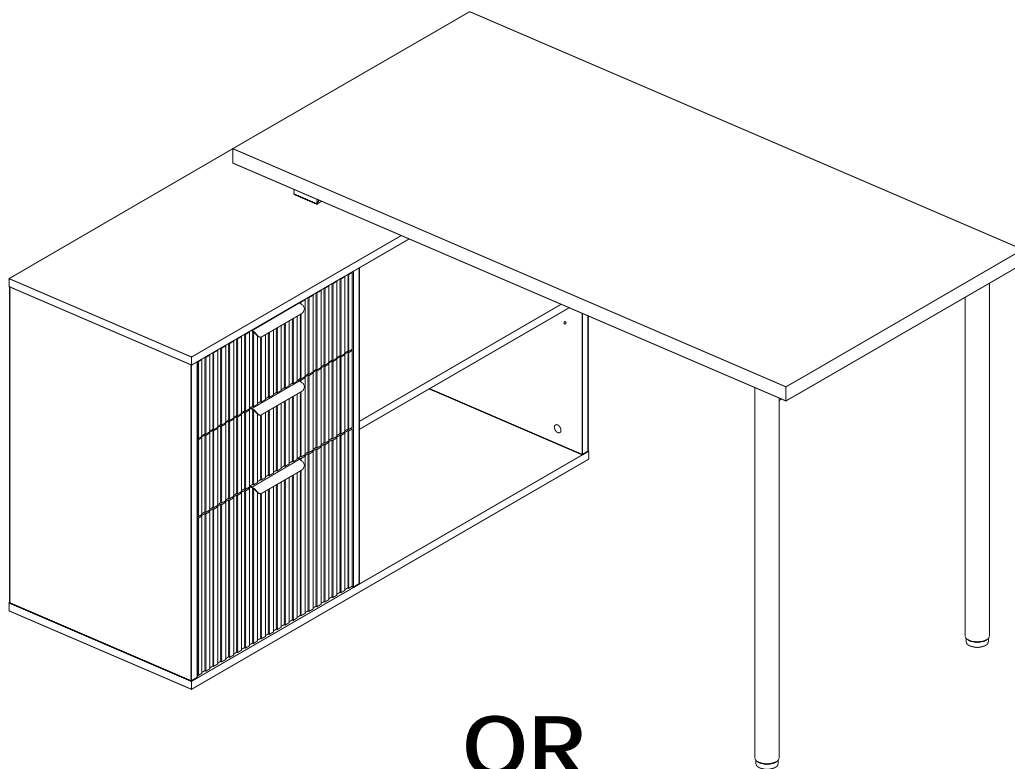

OR

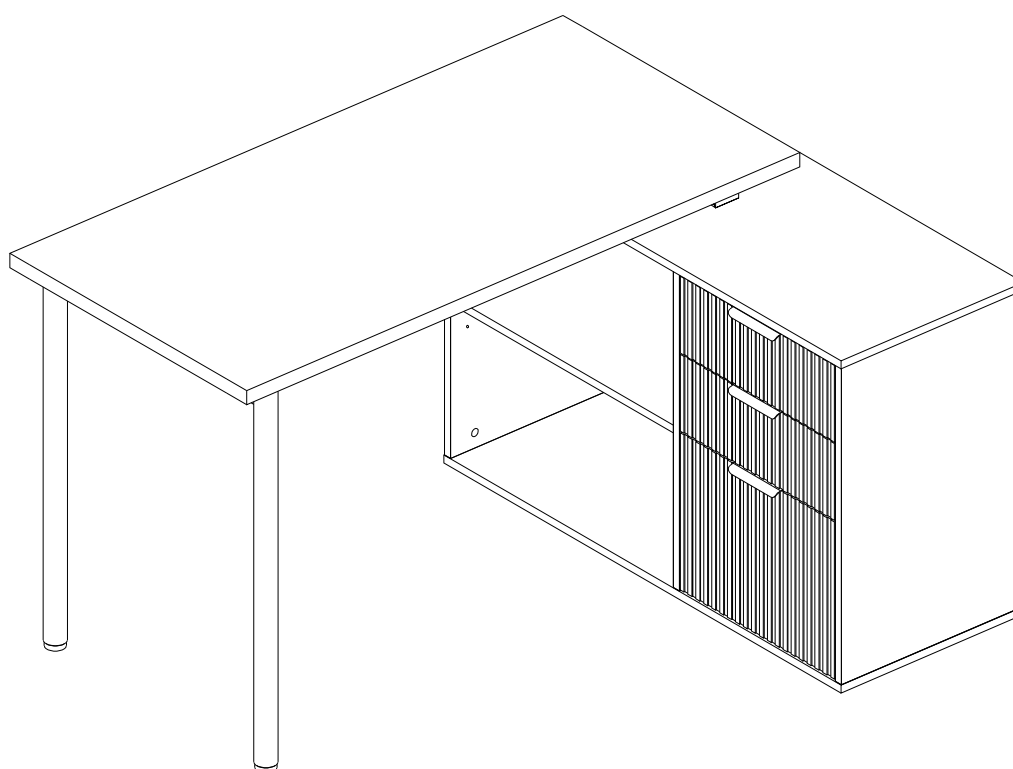

IMPORTANT INFORMATION!

•please read the entire manual before starting to assemble and/or using this product. follow the manual thoroughly and keep it for further reference.

AVOID SCRATCHES!

•In order to avoid scratching this furniture should be assembled on a soft layer-could be a rug.

IMPROVE EFFICIENCY !

•Try to find a partner to install with you, which can speed up the installation efficiency and shorten the time.

IMPORTANT !

•It is important that any product which is assembled using any kind of screw is re-tightened 2 weeks after assembly, and once every 3 months - in order to assure stability through-out the lifespan of the product.

•For regular maintenance and cleaning of the product, for the frame, please use a rag dipped in neutral detergent to fully wipe it, and then dry it with a clean rag. For glass materials, wipe with a rag dampened with water glass cleaner, and then dry with a dry rag.

•Do not use an electric screwdriver, and do not use too much force when installing, because the board is easy to break.

ANTI-TOPPLE WARNING !

Overtured furniture can cause serious or fatal crush injuries. To prevent tipping over, be sure to use the wall attachment, if not included with this product. Please purchase the wall attachment that fit your wall. If unsure, seek professional advice. Please read and follow each step of the instructions carefully.

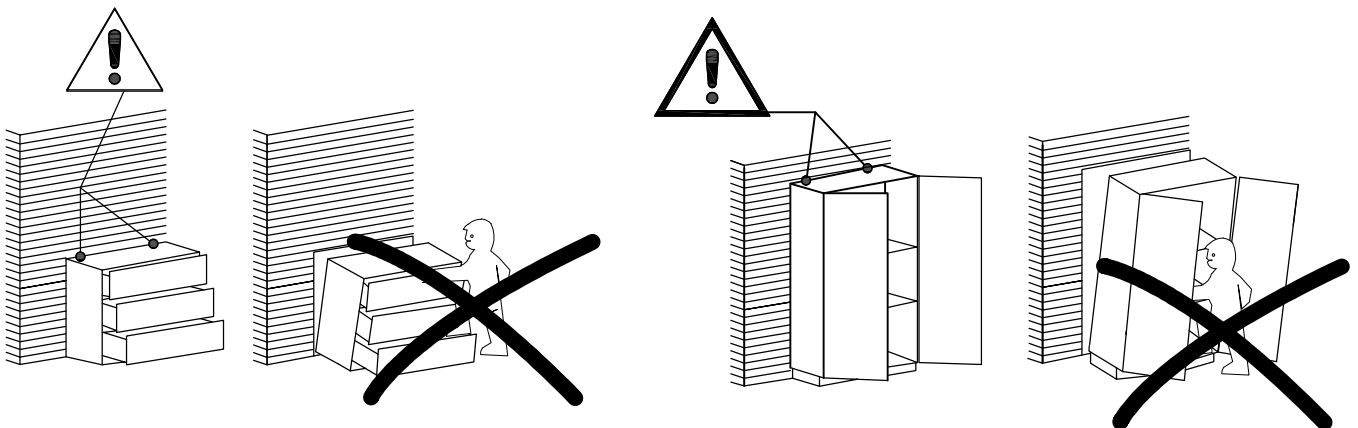

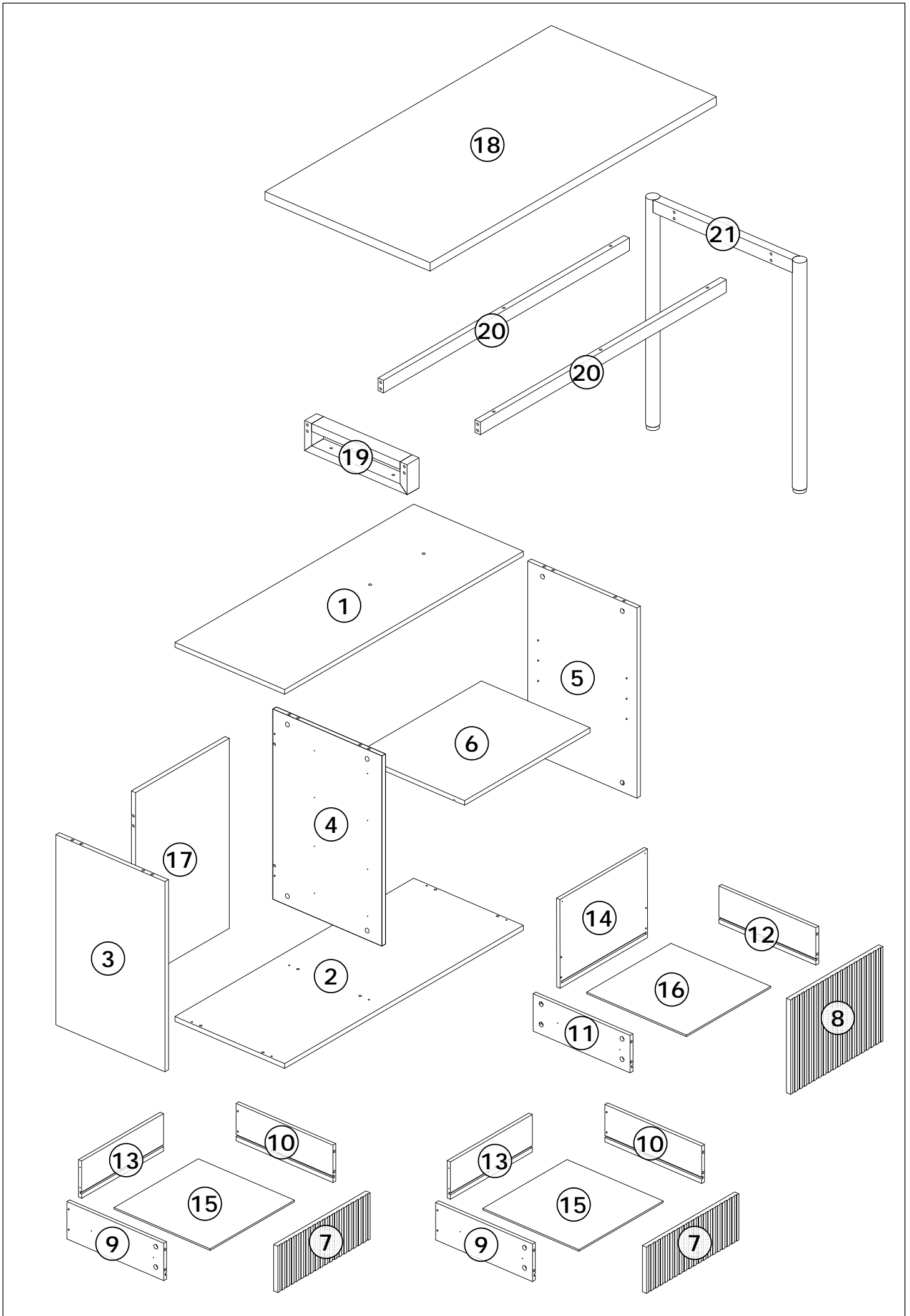

**Slides Must Be Separated Before Assembly.
After Separated, Set Aside Until Needed for Assembly.**

Las diapositivas deben separarse antes del montaje.
Después de la separación, déjelo a un lado hasta que sea necesario.

Les glissières doivent être séparées avant l'assemblage.
Après la séparation, mettez de côté jusqu'au moment de l'assemblage.

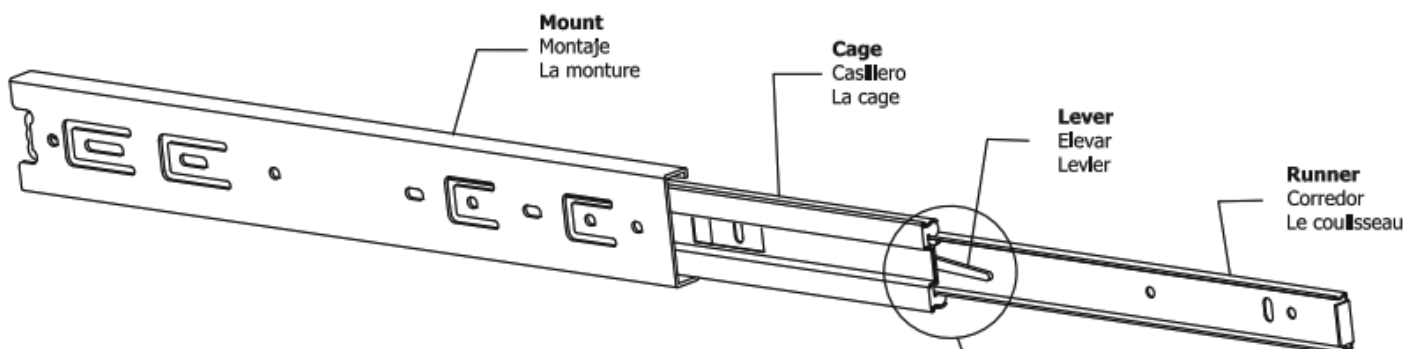

STEP 1: Extend Slide
Extender la diapositiva
Extendre la diapositive

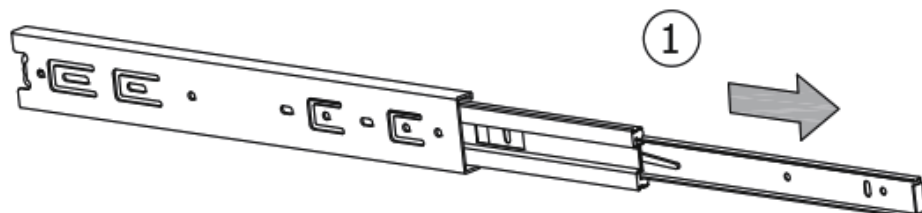

STEP 2: Push Lever UP
Empujar hacia arriba
Lever le levier

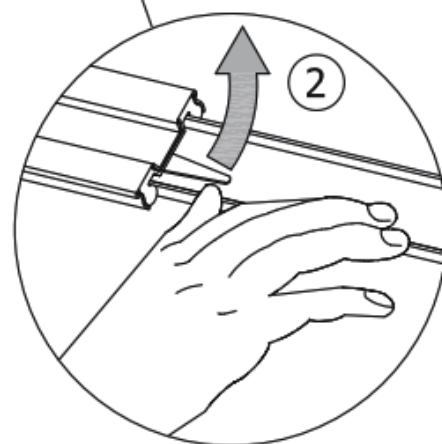

STEP 3: Remove Runner
Quitar el corredor
Enlever le coureur

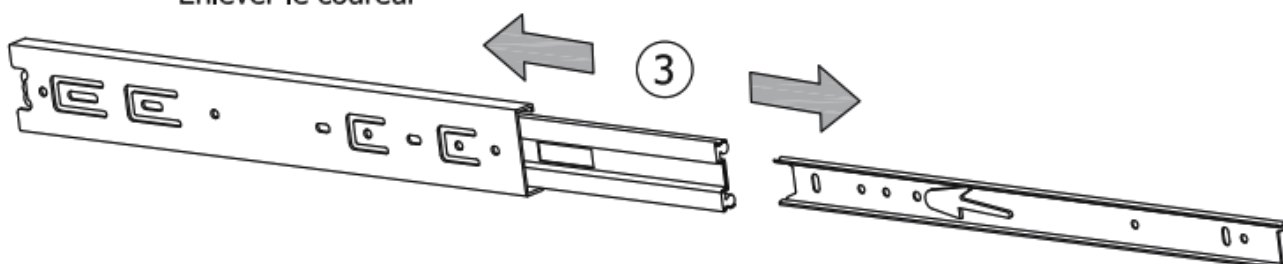

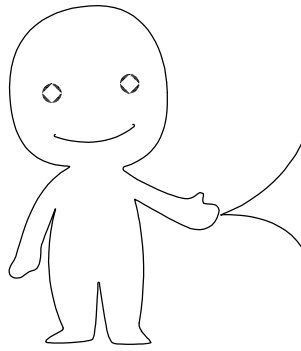

Please prepare the following tools

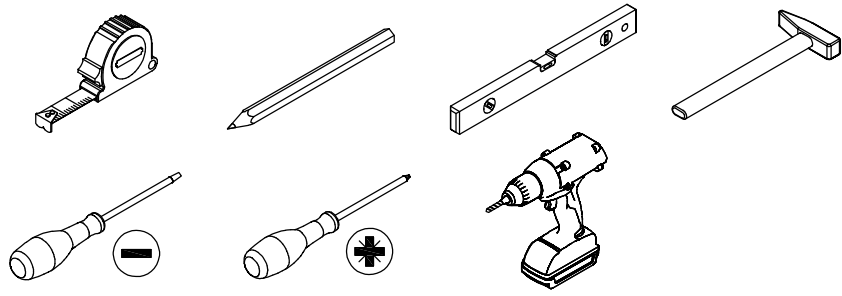

When installing, please carefully confirm whether each screw corresponds to the manual, accessories with similar shapes can be distinguished by size

A x 32

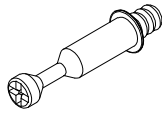

CRA0635A

B x 32

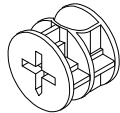

CRB1595A

C x 16

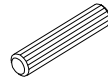

CRF0830A

D x 8



CRD0430A

E x 30



CRD3512A

F x 10



CRD0650A

G x 4



CRD0670A

H x 4



Ø4.9*16mm

J x 3

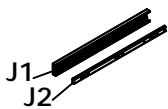

HG3508-14"

K x 2



CRD0635A

L x 3

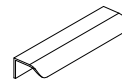

M x 2

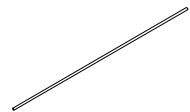

N x 1



P x 1



Q x 8



R x 2

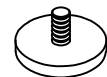

1

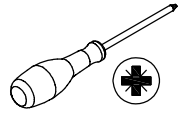
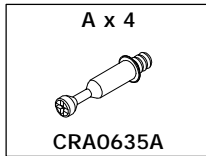

1.As Place screws (A)x4 on components (3), (4) and tighten as shown.

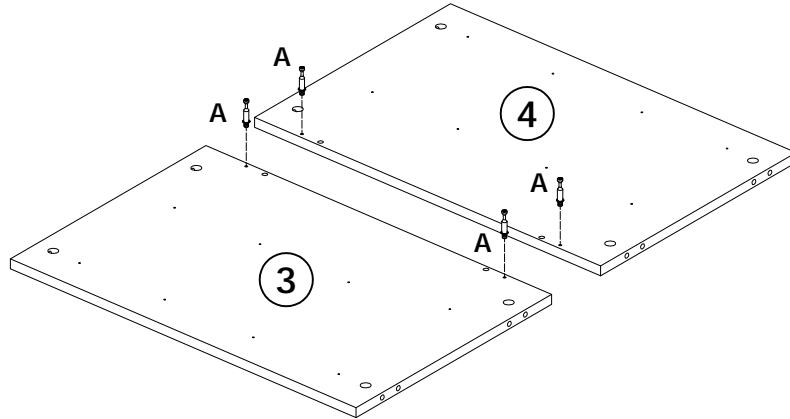
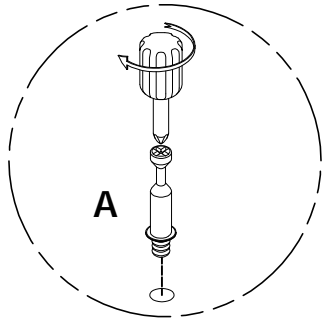
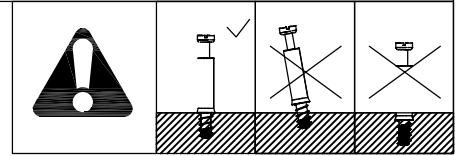

2

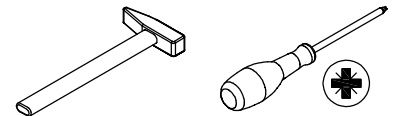
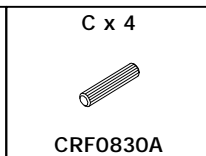
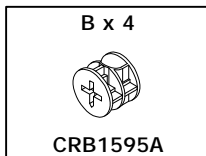

1.As Place the screws (C)x4 on the component (17) as shown; Place components (3) (4) in the corresponding positions of components (17) and tighten them with screws (B)x4.

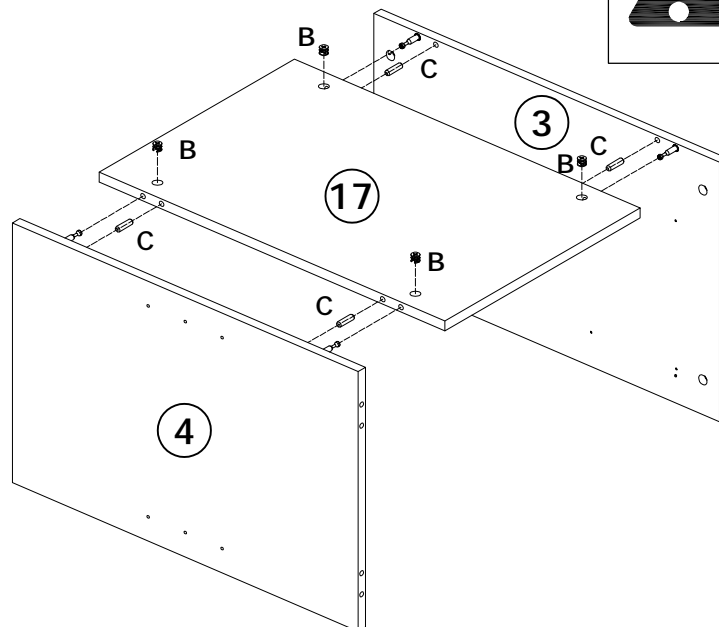
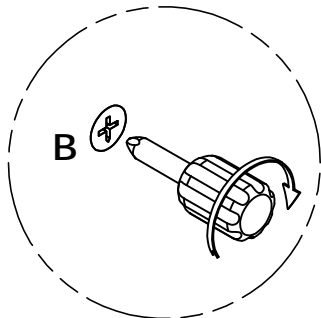
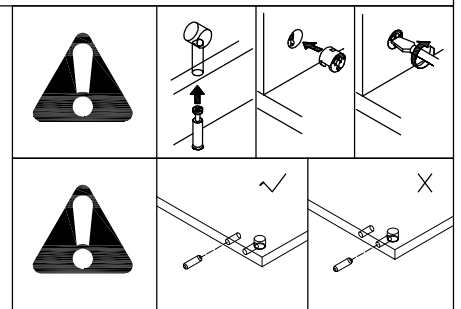

3

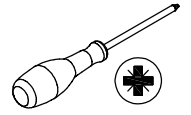
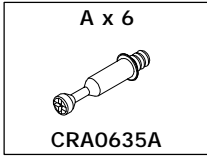

1.As Place the screw (A)x6 on the assembly (2) as shown and tighten it.

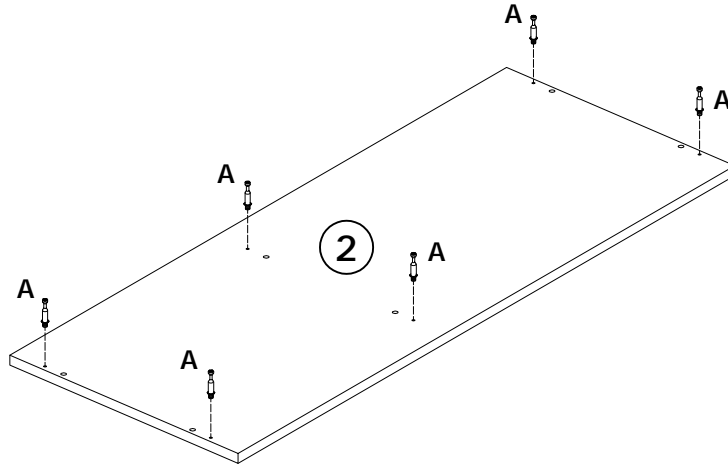
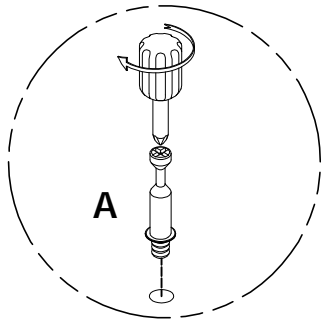
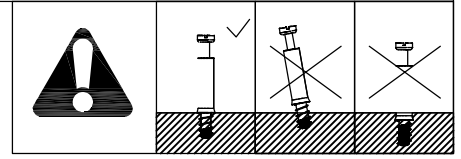

4

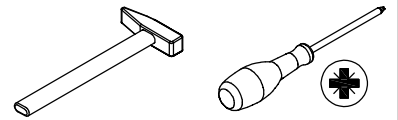
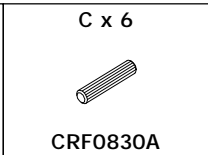
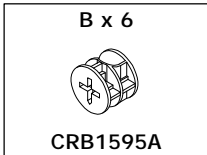

1.As Place the screw (C)x6 on the component (2) as shown; Place the assembly (3)(4)(5) in the corresponding position of the assembly (2) and tighten it with screws (B)x6.

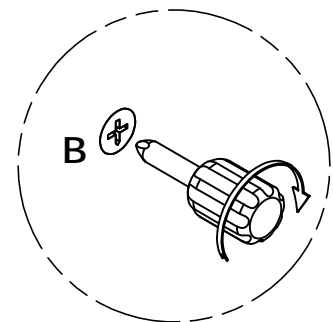
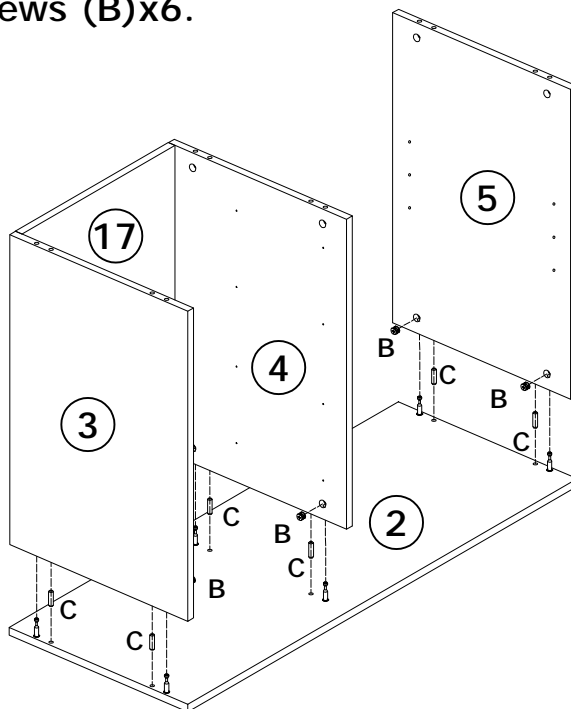
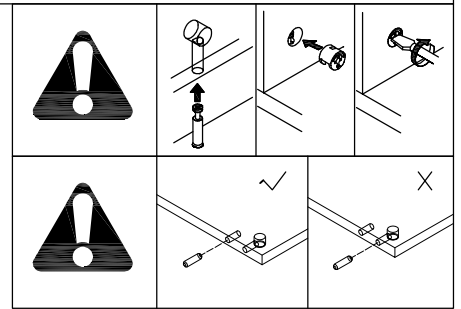

5

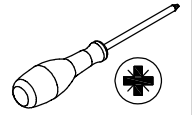
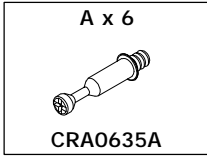

1.As Place the screw (A)x6 on the assembly (1) as shown and tighten it.

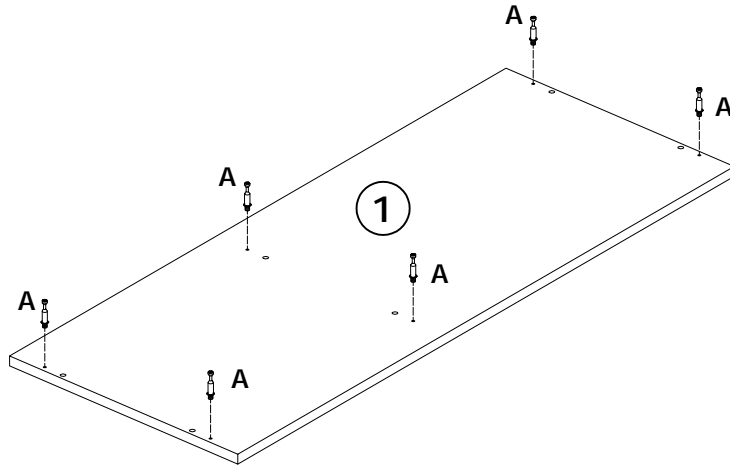
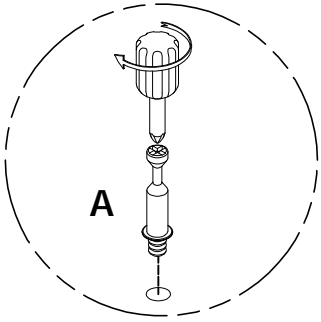
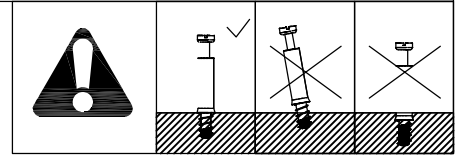

6

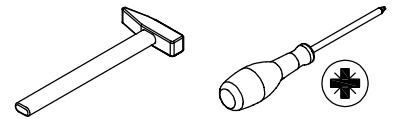
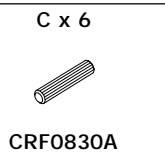
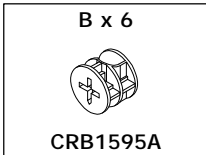

1.As Place the screw (C)x6 on the component (1) as shown; Place the assembly (3)(4)(5) in the corresponding position of the assembly (1) and tighten it with screws (B)x6.

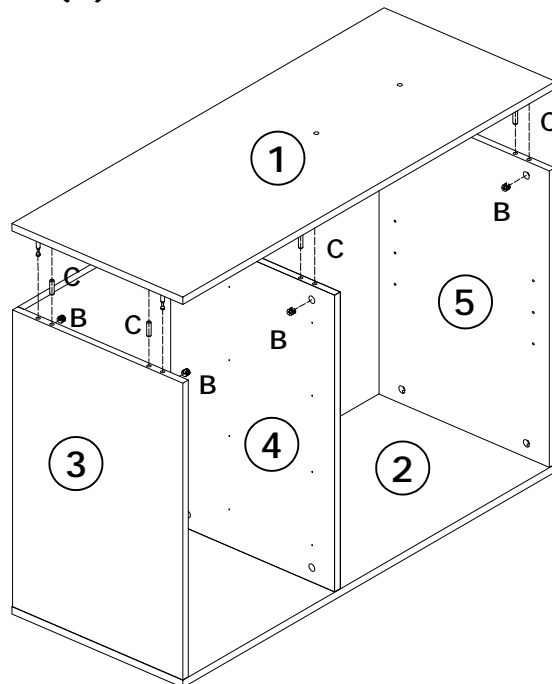
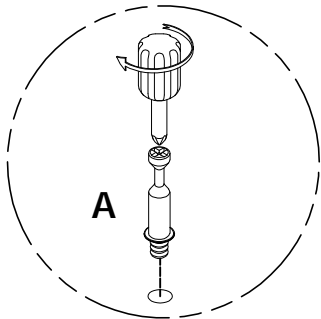
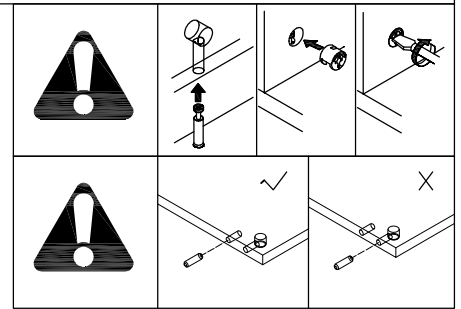

7



1.As Place attachment (J2)x2 on assembly (9)(10)x2 as shown and tighten with screw (E)x8.

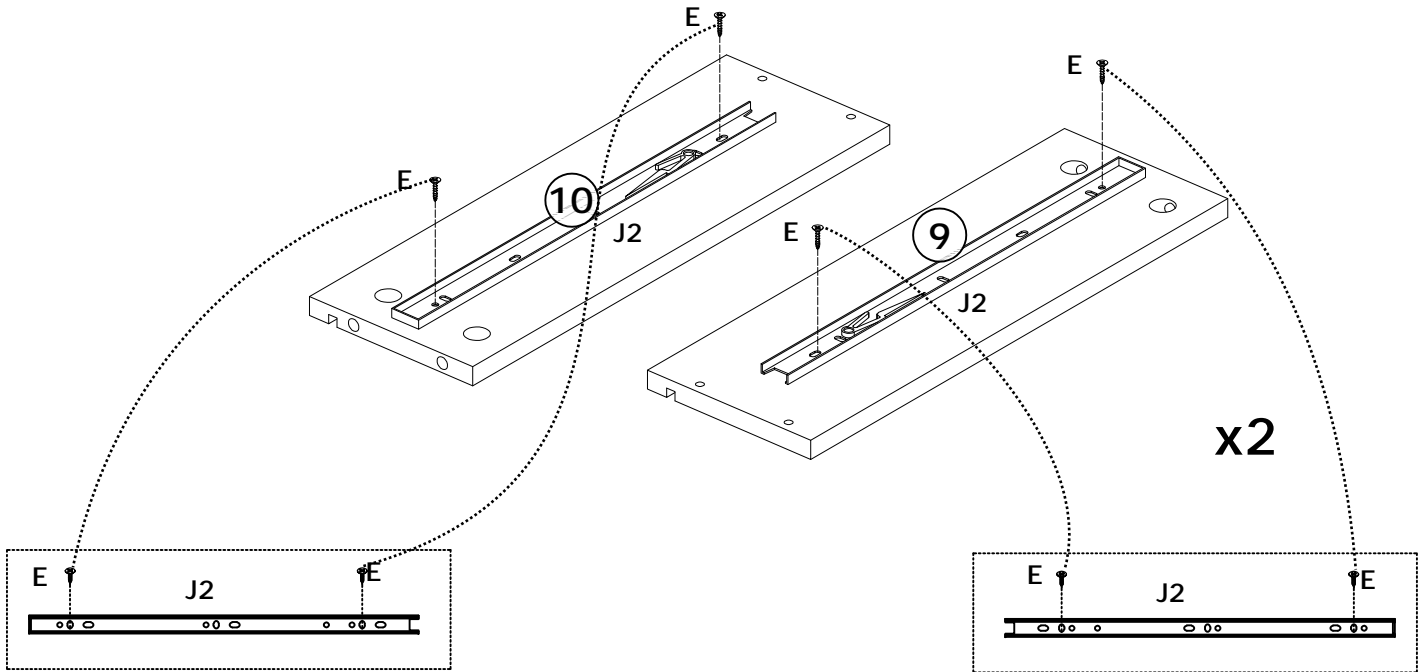

8

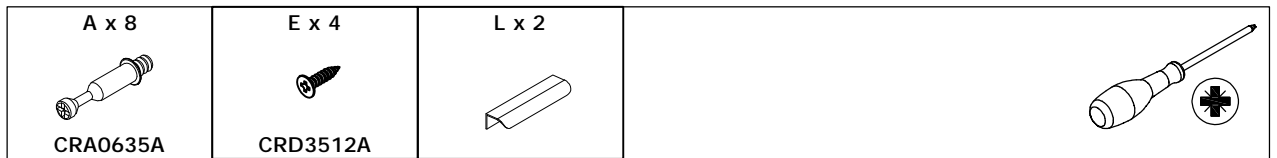

1.As Place the screw (A)x8 on the assembly (7)x2 as shown and tighten it.

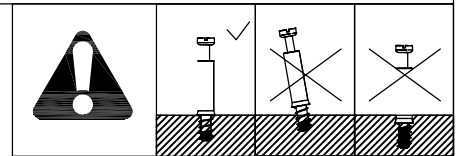

2.As Place the attachment (L)x2 on the assembly (7)x2 as shown and tighten it with screws (E)x4.

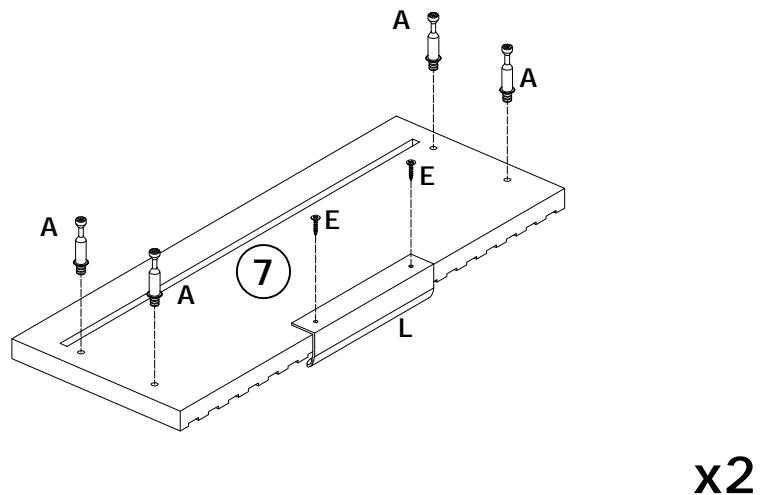

9

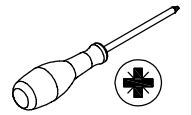
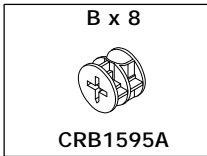

1.As Place element (9)(10)x2 at the corresponding position of element (7)x2 as shown and tighten it with screws (B)x8.

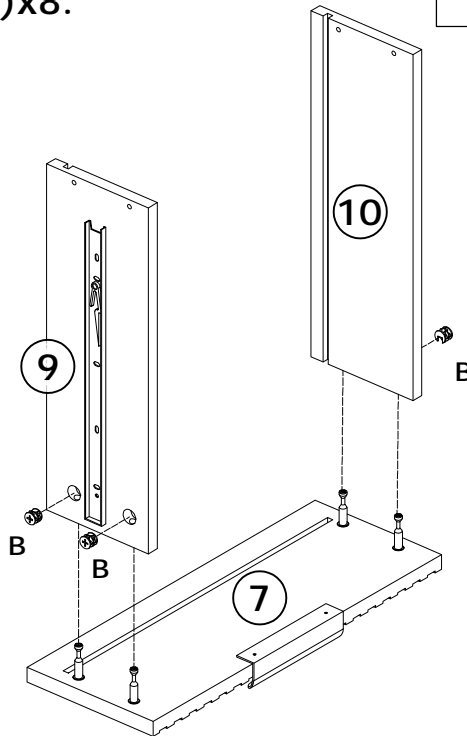
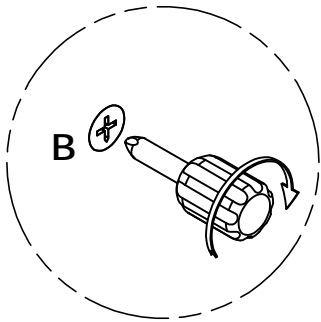
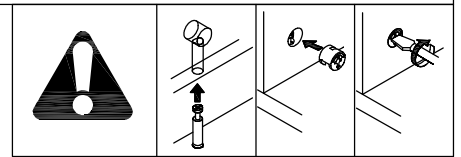

10

1.As Push the component as shown in the image (15) Put it into the assembled parts.

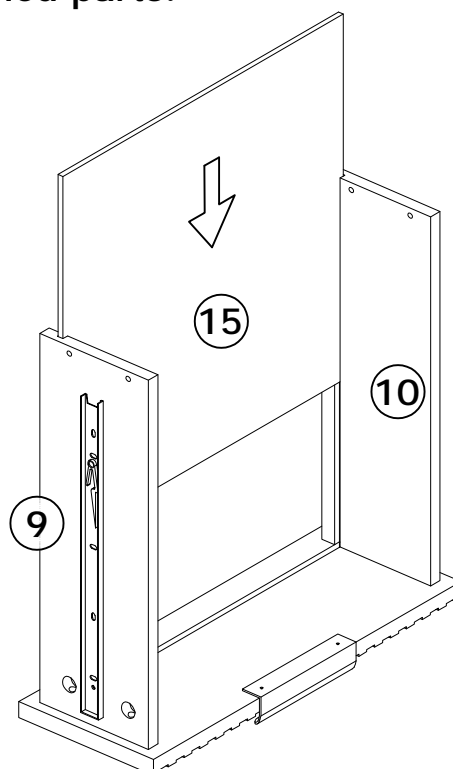

11

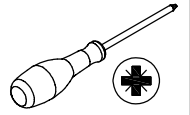
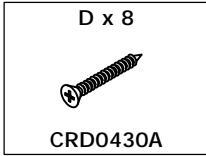

1. Use screws (D) x8 to tighten the assembled parts from the bottom.

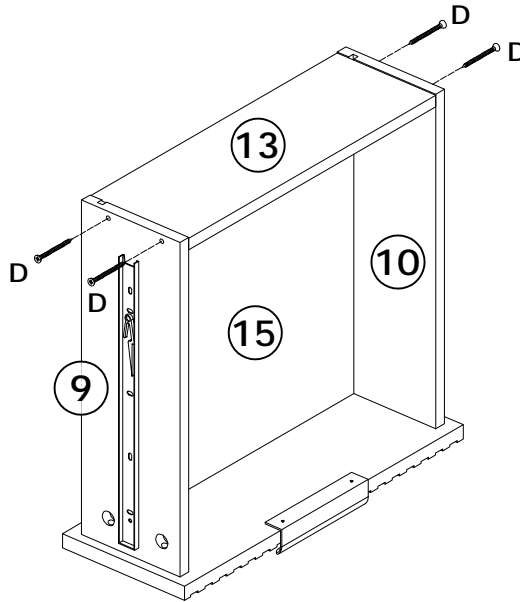
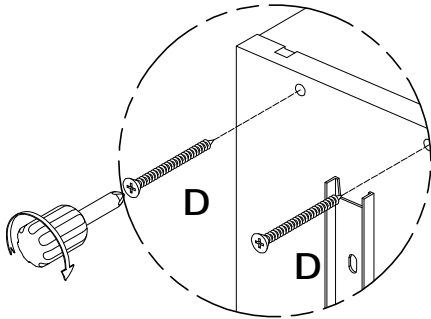

x2

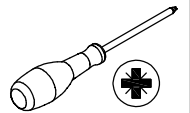
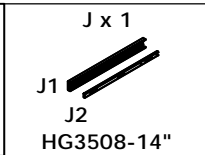
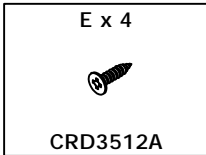

12

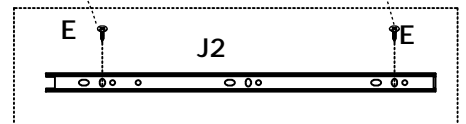
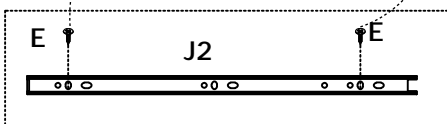
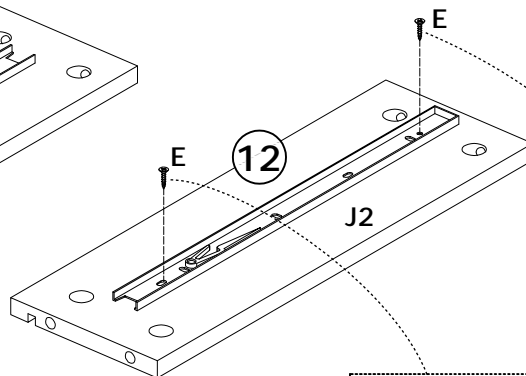
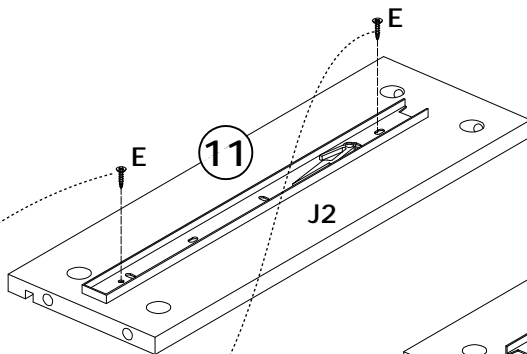

1. As Place attachment (J2)x1 on assembly (11)(12)x1 as shown and tighten with screw (E)x4.

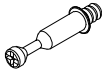

13

A x 4  CRA0635A	E x 2  CRD3512A	L x 1 
--	--	--

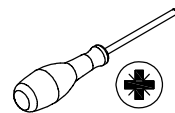

1.As Place the screw (A)x4 on the assembly (8) as shown and tighten it.

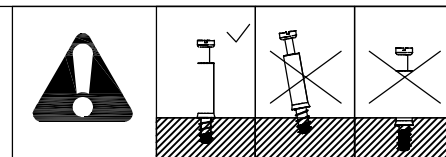

2.As Place the attachment (L) on the assembly (8) as shown and tighten it with screws (E)x2.

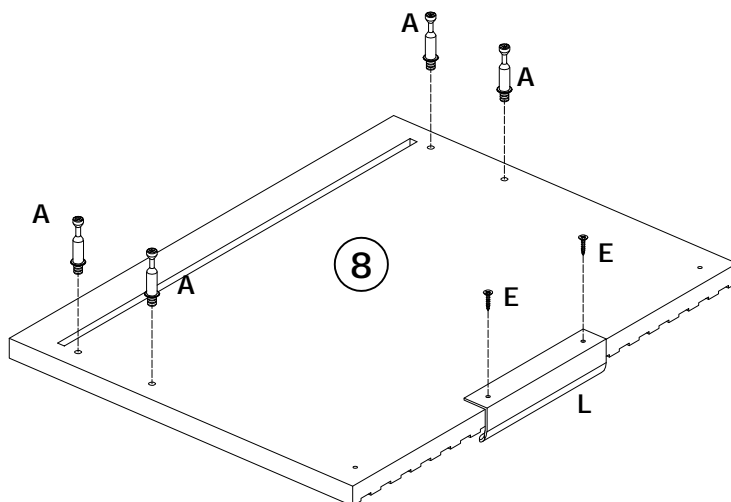
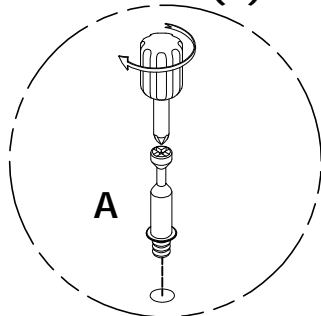

14

B x 4  CRB1595A
--

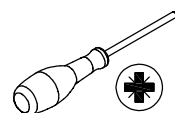

1.As Place element (11)(12) at the corresponding position of element (8) as shown and tighten it with screws (B)x4.

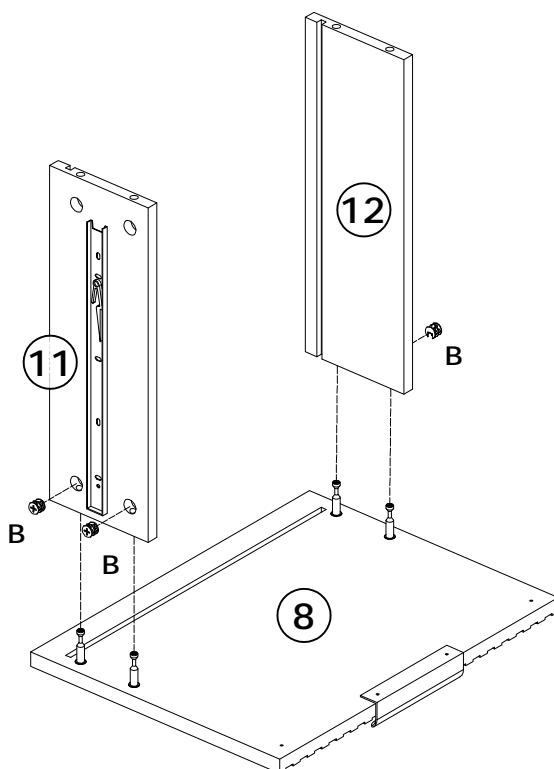
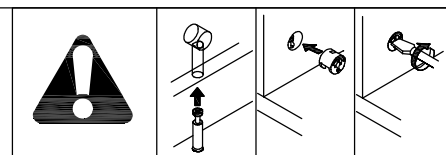

15

1.As Push the component as shown in the image
(16)Put it into the assembled parts.

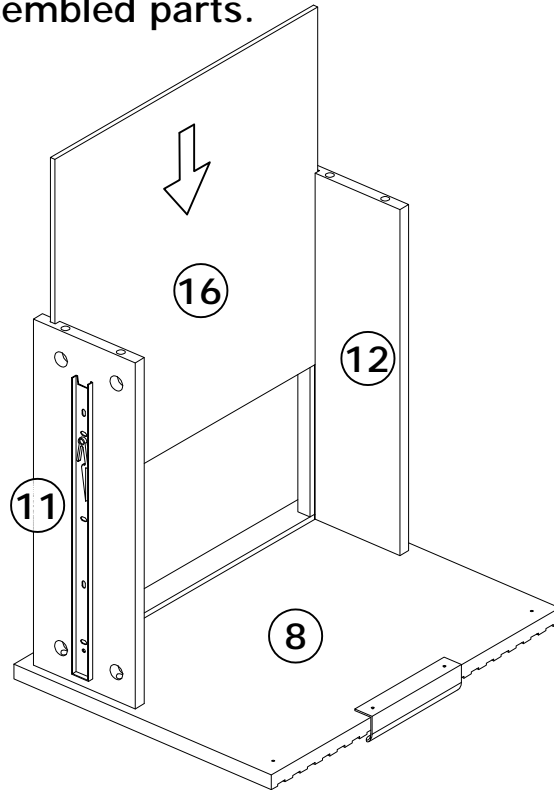

16

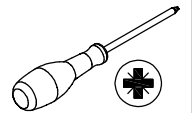
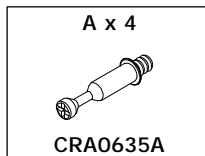

1.As Place the screw (A)x4 on the assembly (14)
as shown and tighten it.

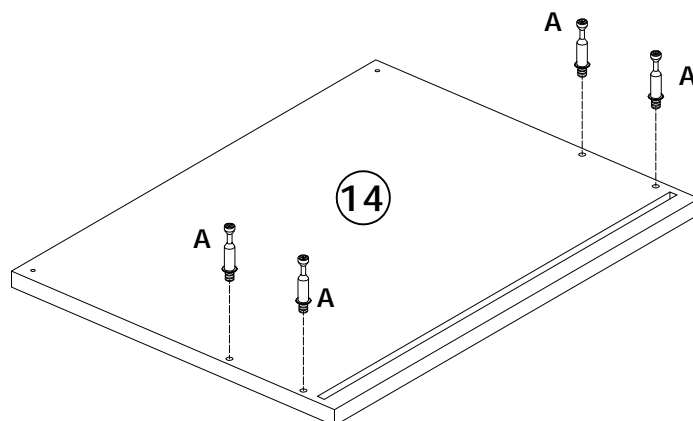
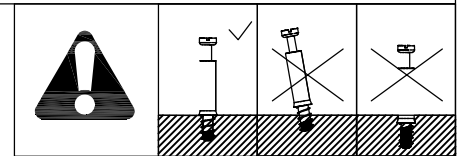

17

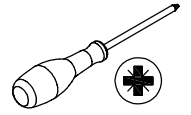
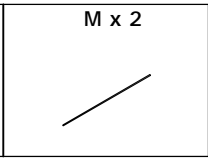
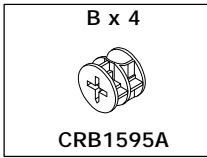

1. As shown in the figure, put the part (M)x2 at the corresponding position of the part (14), then put the part (14) at the corresponding position of the assembled part, and tighten it with screws (B) x4

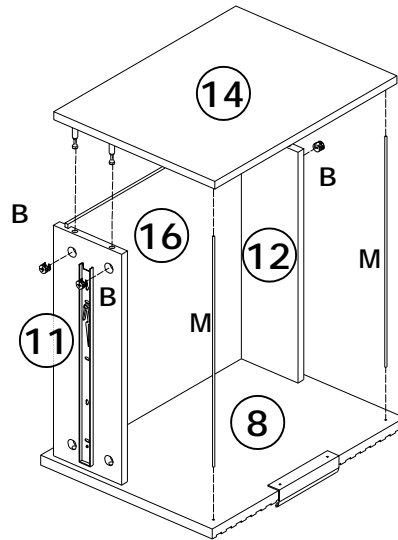
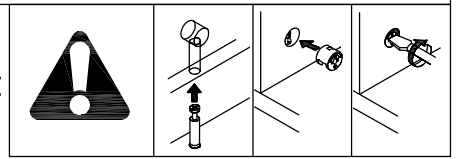

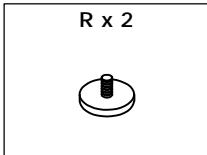

18

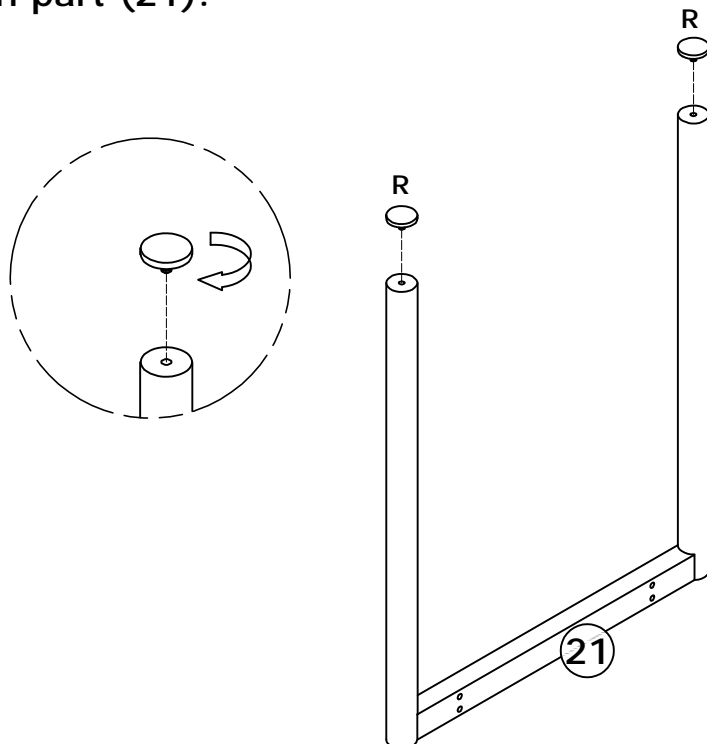

As shown in the figure, use accessory (R) x2 to screw in part (21).



19

F x 4  CRD0650A	G x 4  CRD0670A	N x 1 	
--	--	--	--

1. Tighten parts (19) and (20) with screws (G) x4.

2. Tighten parts (21) and (20) with screws (F) x4.

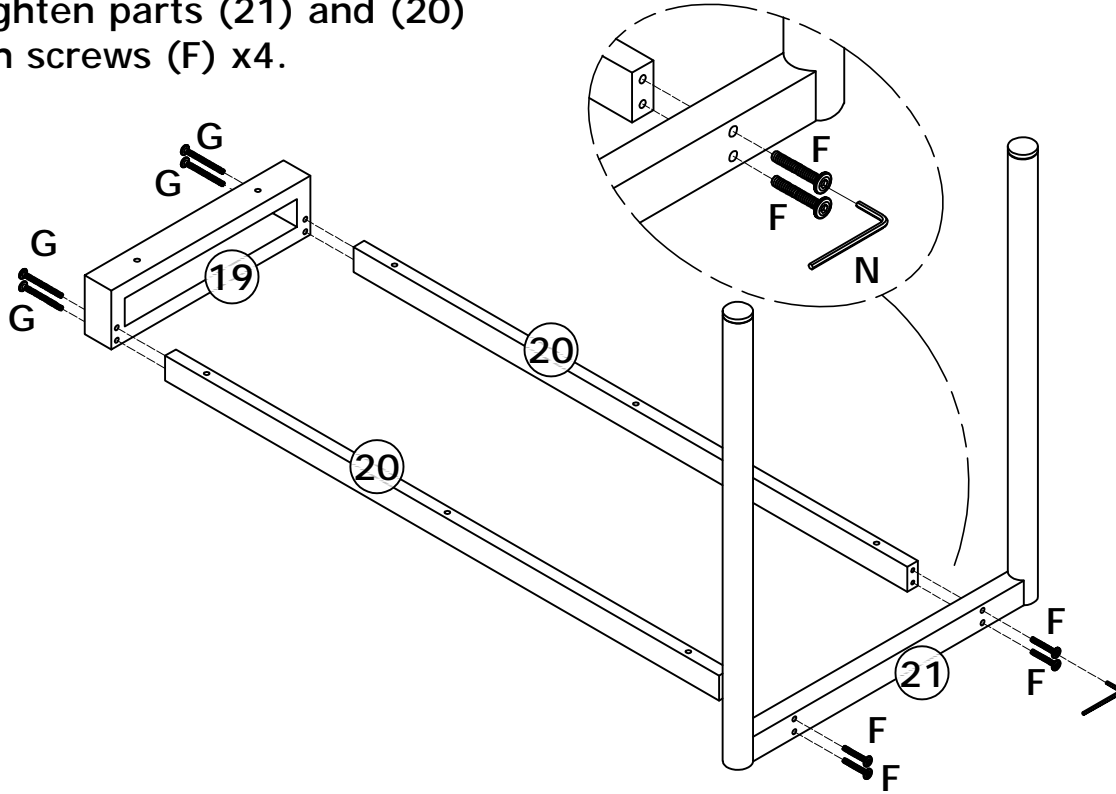

20

P x 1 	
--	--

As shown in the figure, stick accessory (P) onto component (19).

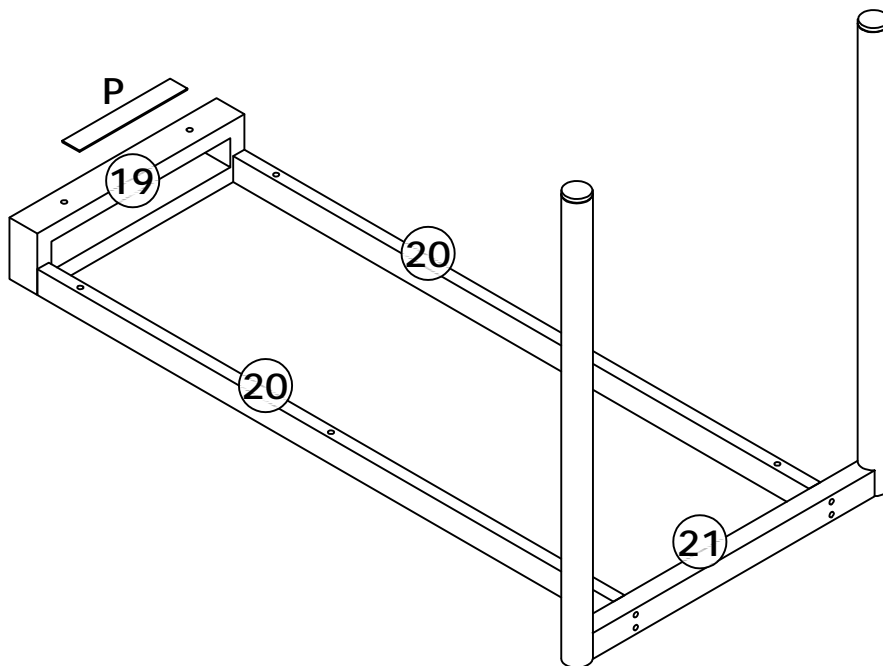

21

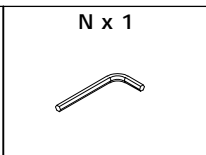
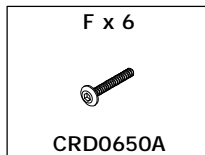

As shown in the figure, the assembled parts are locked in the corresponding position of part (18) with screws (F) x6.

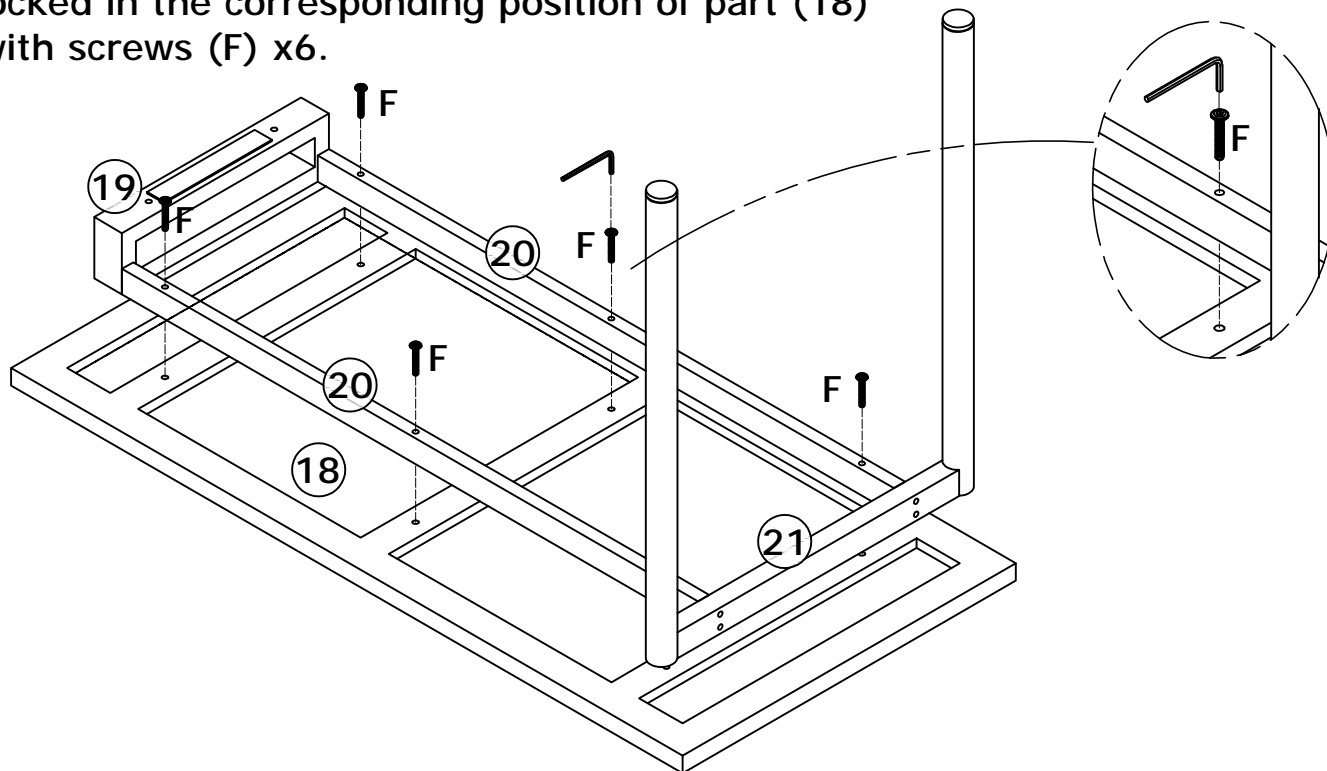

22

Confirm the required completion style.:

Option 1: Drawer on the left

Option 2: Drawer on the right

Option 1

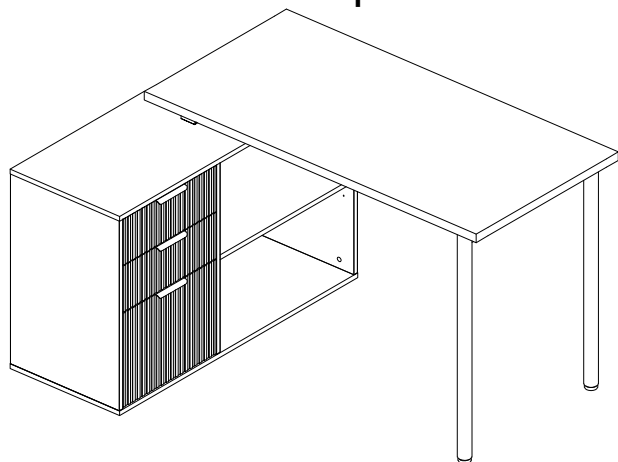

OR

Option 2

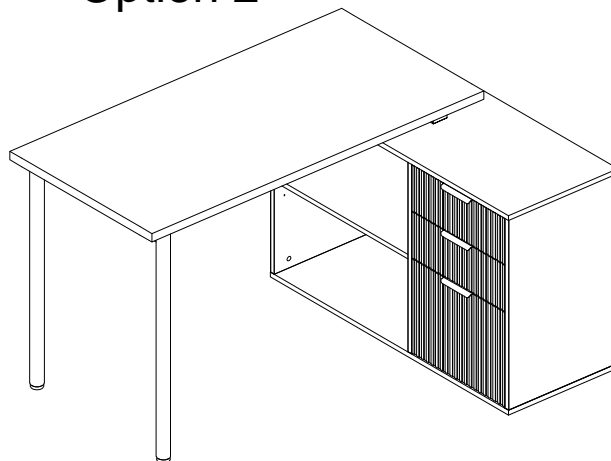

23

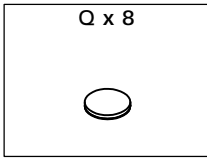

As shown in the figure, paste the attachment (Q) x8 into the corresponding position of component (2).

Option 1

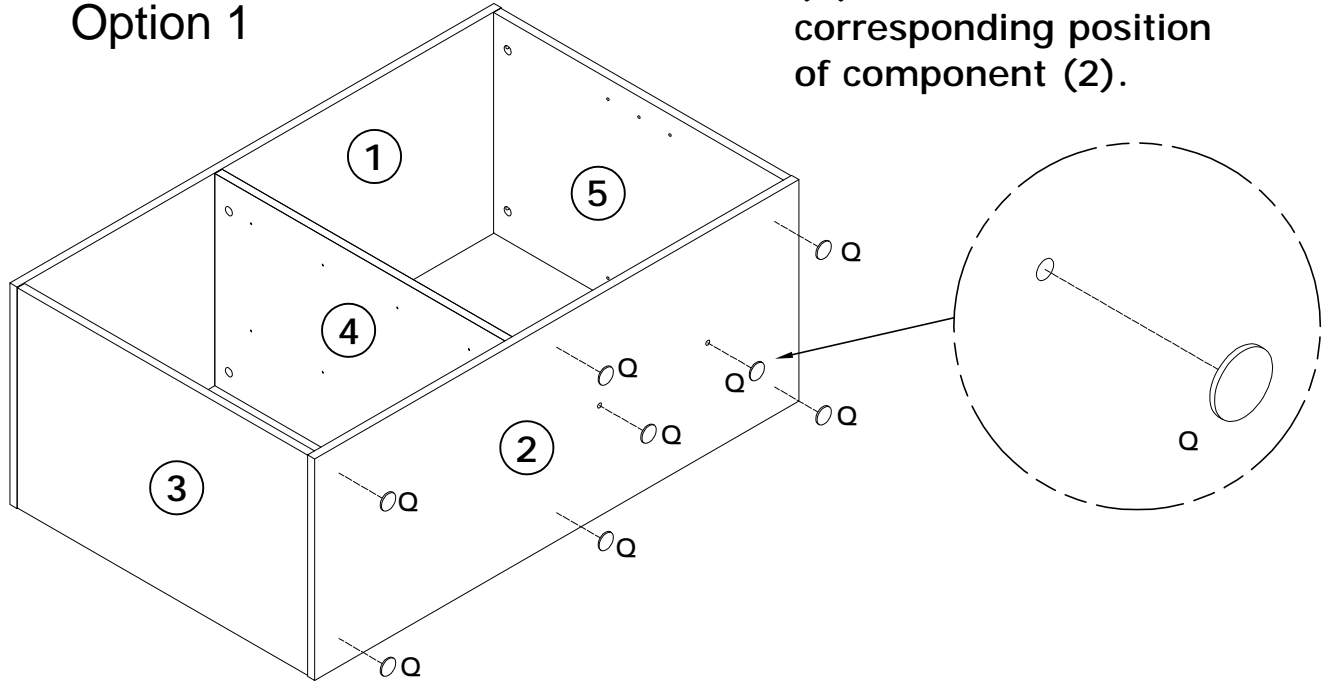

OR

As shown in the figure, paste the attachment (Q) x8 into the corresponding position of component (1).

Option 2

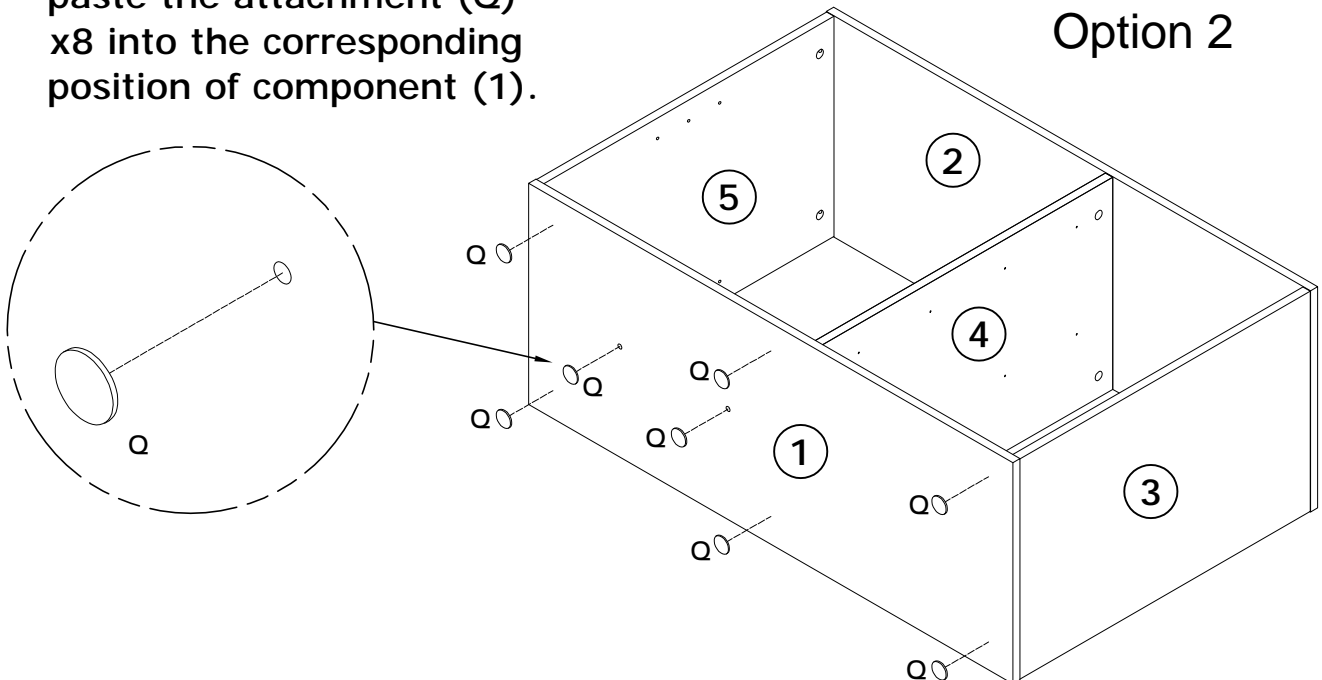

24

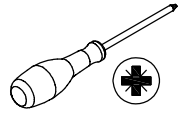
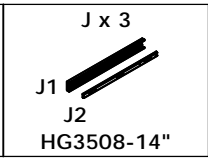
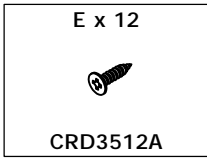

As Place attachments (J1) x3 in the corresponding holes of components (3) and (4) respectively as shown in the figure, and tighten them with screws (E) x12.

Option 1

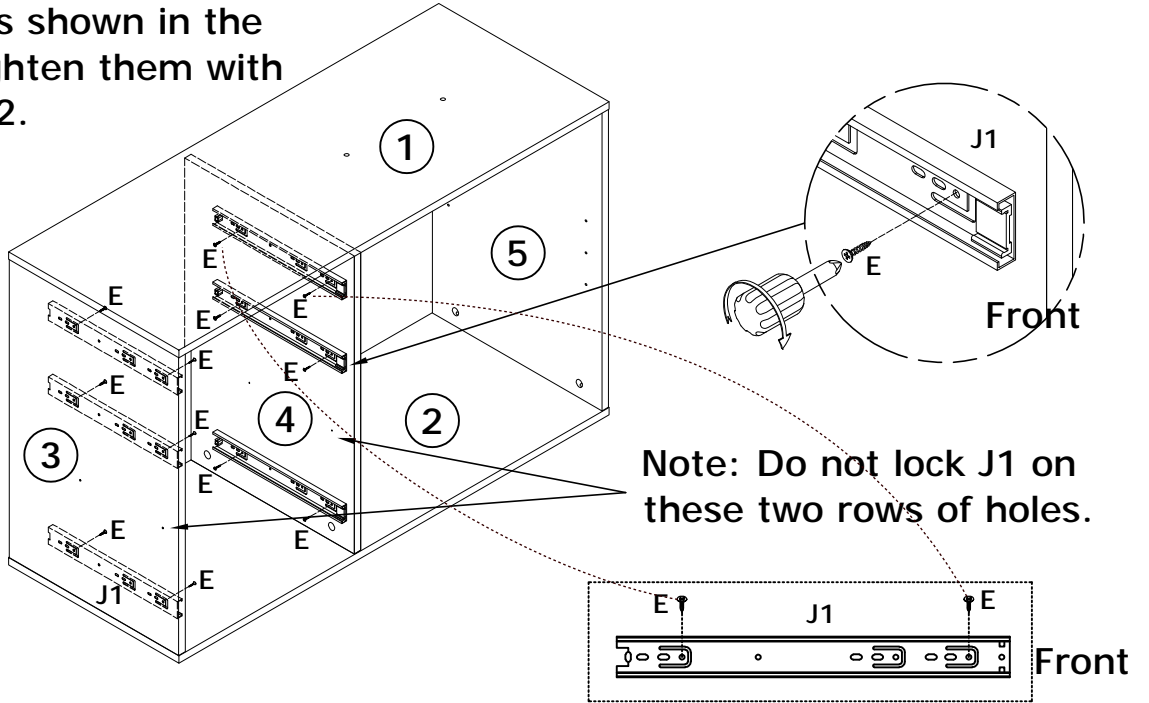

OR

Option 2

As Place attachments (J1) x3 in the corresponding holes of components (3) and (4) respectively as shown in the figure, and tighten them with screws (E) x12.

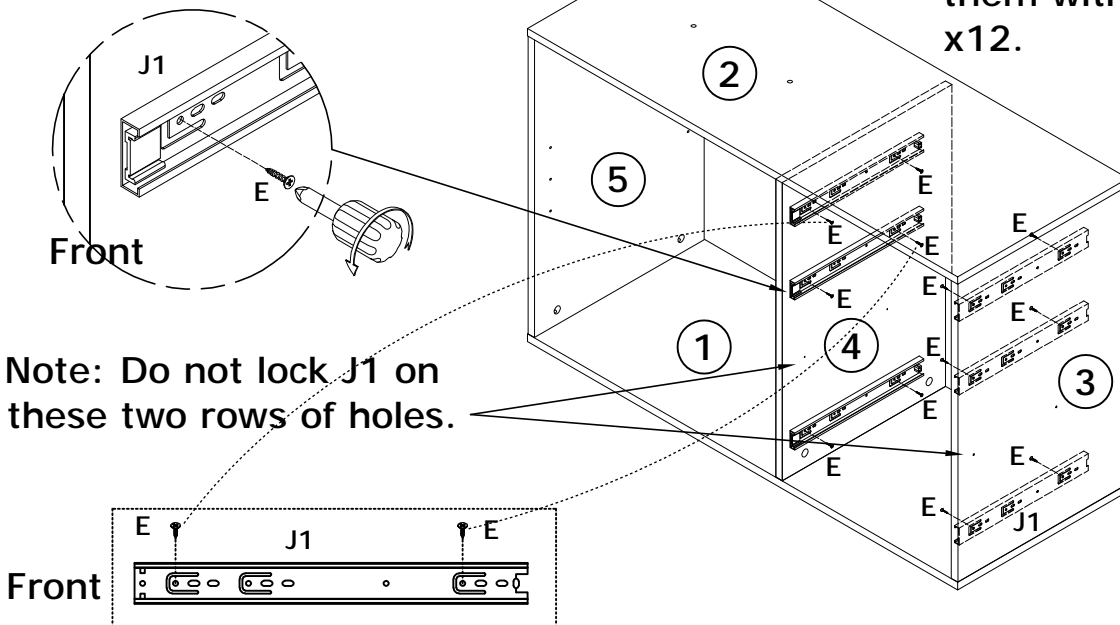

25

Find the appropriate angle and push the drawer in.

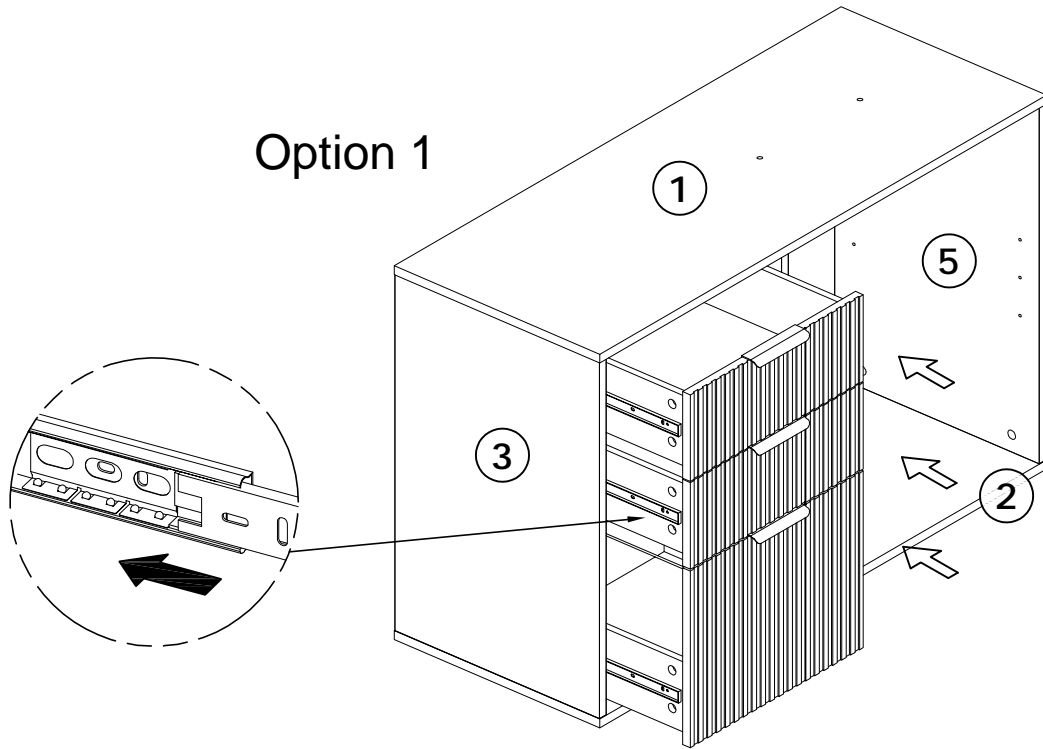

OR

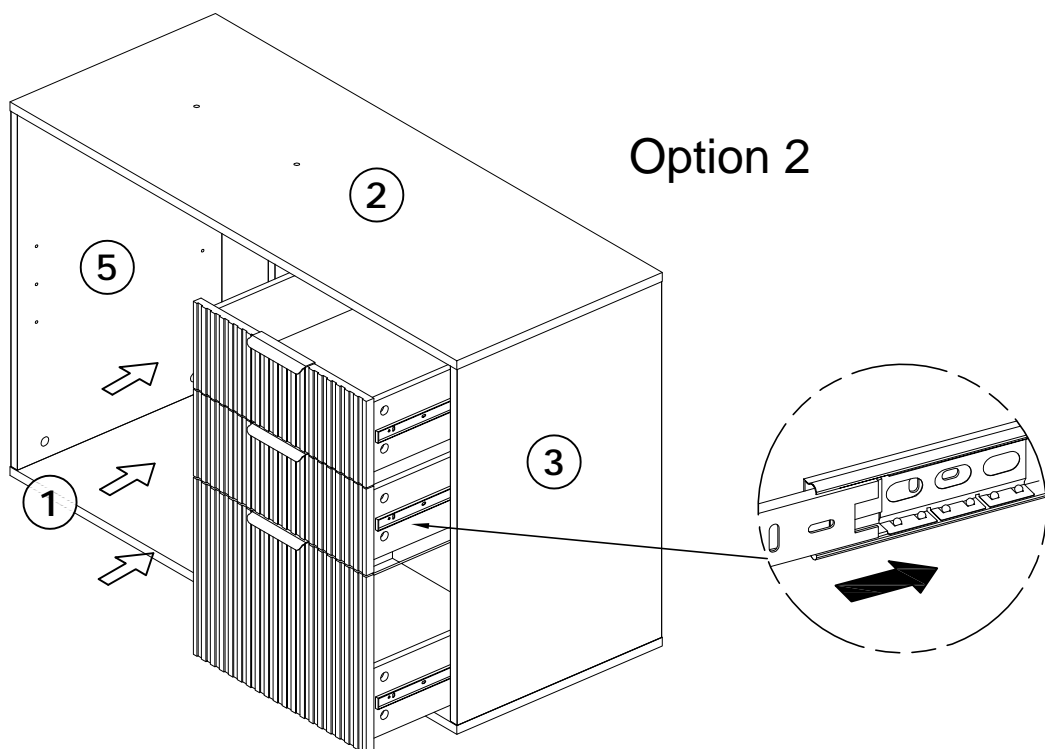

26

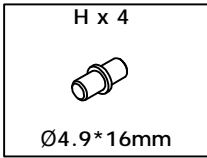

Option 1

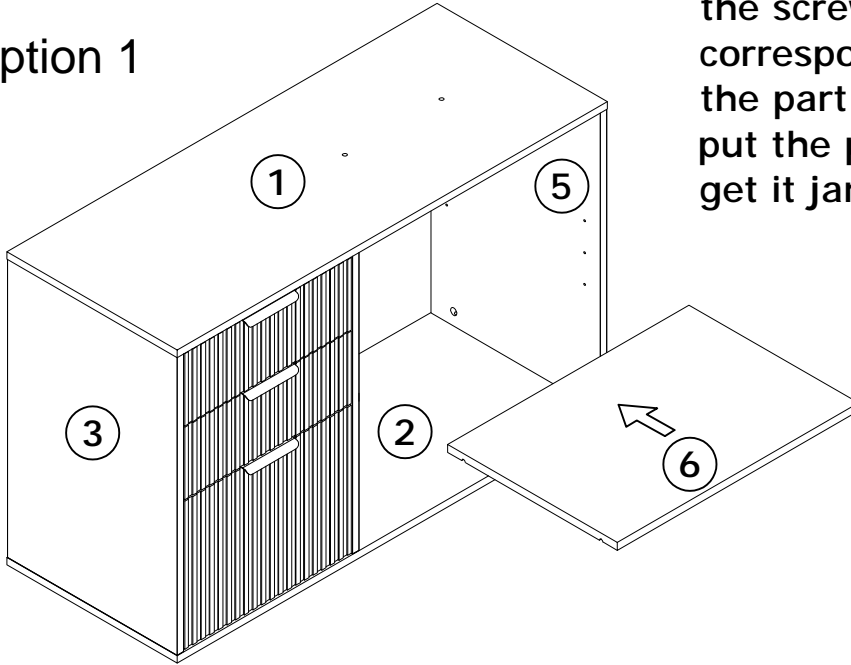

As shown in the figure, put the screw (H)x4 into the corresponding position of the part (4) and (5), and put the part (6) on it and get it jammed

OR

As shown in the figure, put the screw (H)x4 into the corresponding position of the part (4) and (5), and put the part (6) on it and get it jammed

Option 2

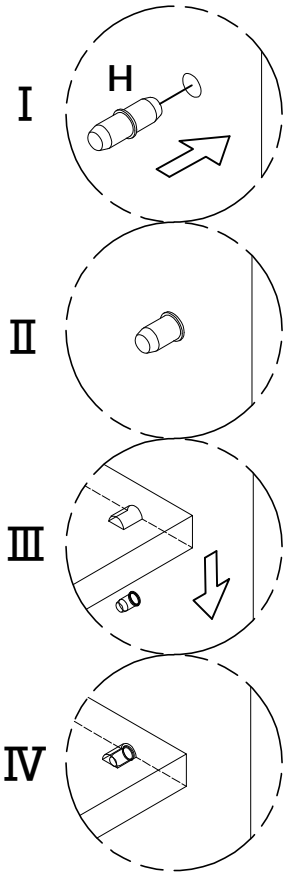
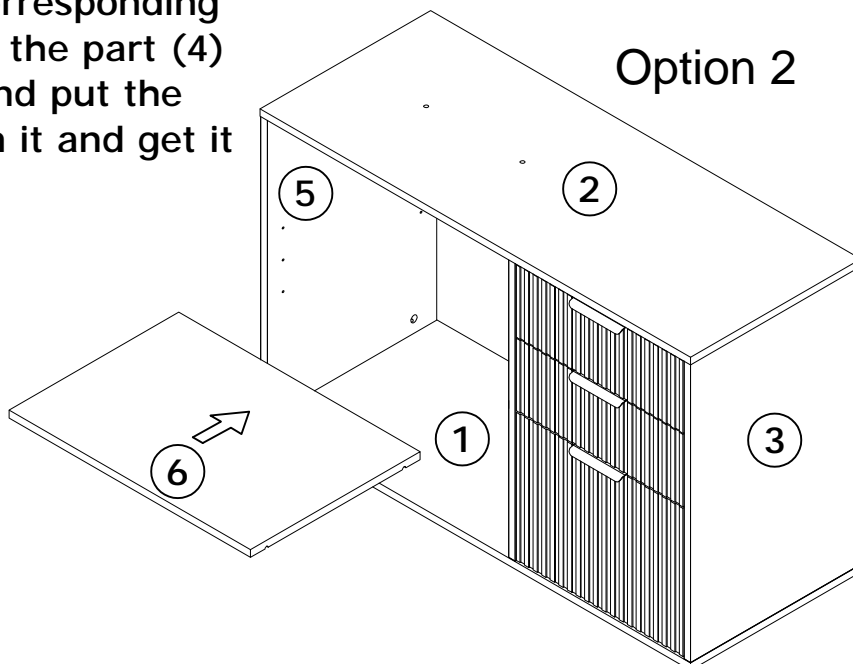

27

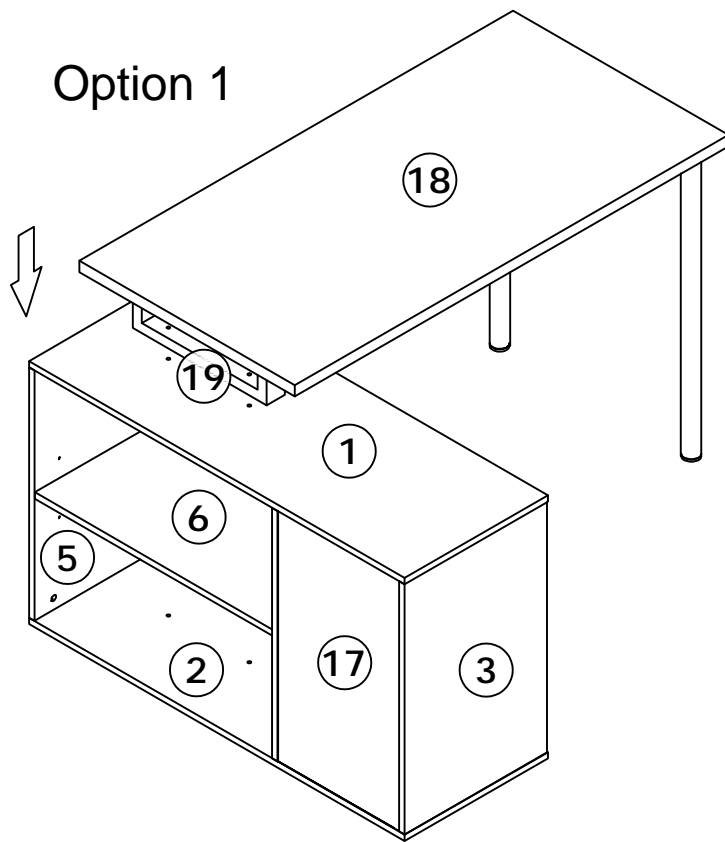

OR

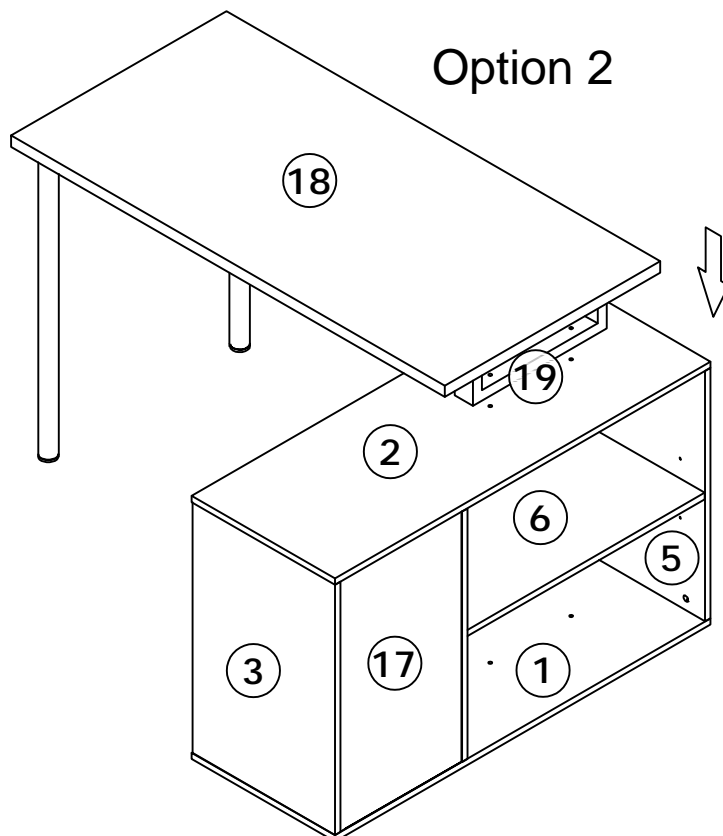

K x 2  CRD0635A	N x 1 	
--	--	--

Option 1

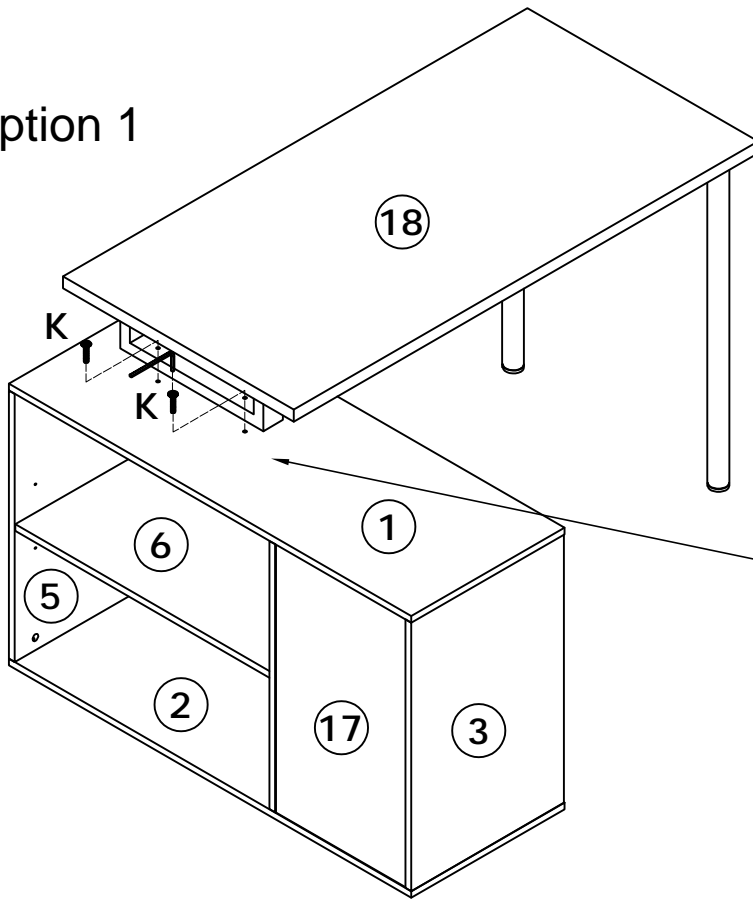

As shown in the figure, use screw (K) x2 to connect accessories (1) and (19).

OR

Option 2

As shown in the figure, use screw (K) x2 to connect accessories (2) and (19).

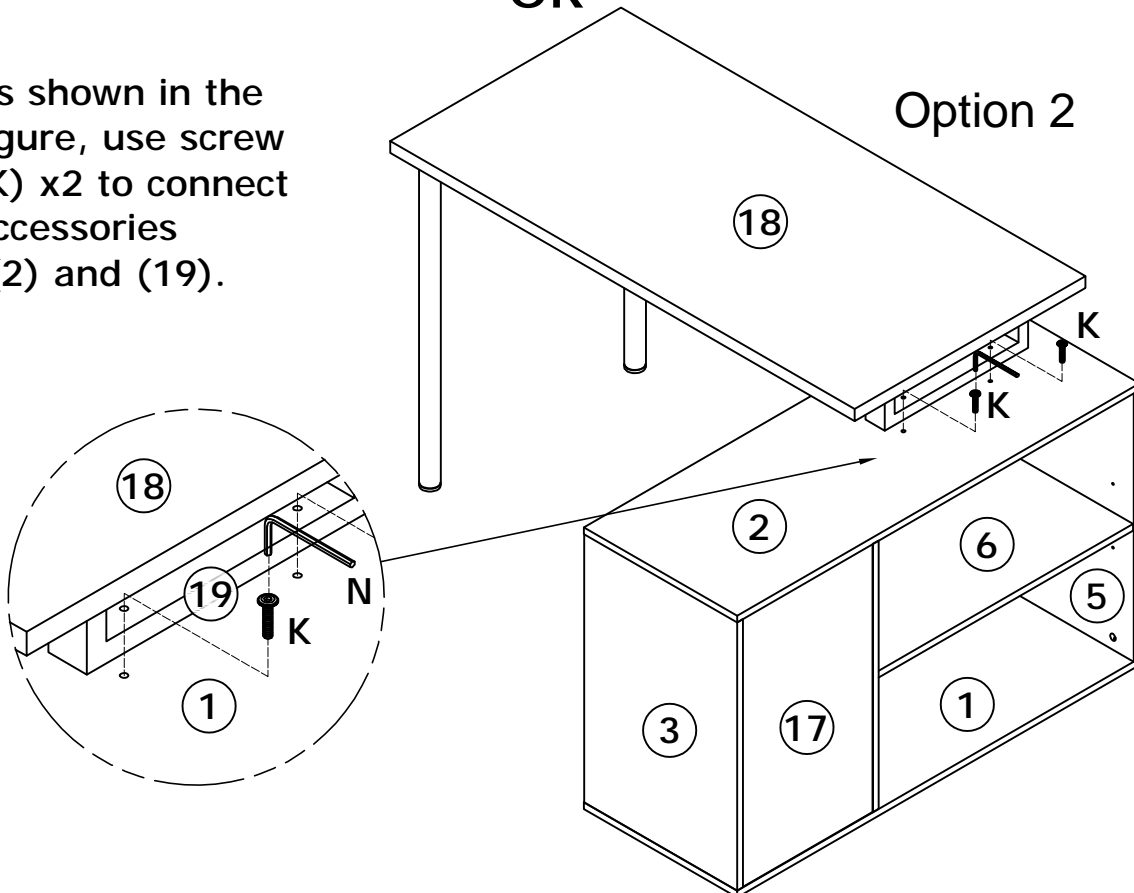

WARRANTY

WARRANTY CLAIMS

- There is a 30-day warranty for broken furniture or any other problems that do not work properly. The warranty will start from the date of purchase which must be verified by proof of purchase.
- The product must be used in accordance with the instructions provided. For health reasons.
- For other reasons, if the furniture needs to be returned, it must be cleaned and dried and operated within 30 days of receipt.

Type of Warranty Claim

- Failure to follow the furniture instructions will invalidate the warranty. Attention please.
- Does not include damage during installation, but includes damage during transportation.

Scope of responsibility

- Shall not bear any responsibility for misuse or user damage and / or loss of parts during the installation of furniture.
- After using, the damage and scratches of the furniture are not covered by the warranty.

The Warranty Relates to All Bought in The Us and Covers The Following Areas

- Sheet parts: 1 month from the date of purchase.
- Electrical parts: 1 month from the date of purchase.

RETURNS

CHANGED YOUR MIND AND NEED TO RETURN YOU ITEM?

PLEASE FOLLOW THE BELOW INSTRUCTIONS:

- If you have purchased and have simply changed your mind, follow the retailer's instructions for returns.

DEFECTIVE ITEMS

- If your item is defective in any way, i.e. it doesn't work but you can't identify why, in the first instance, please consult our FAQ section at Furniture-AfterSales@outlook.com as there may be a simple solution to the issue.

DAMAGED ITEMS

- If you receive an order with obvious shipping damage from the retailer, then we suggest the delivery is refused. If the delivery has been accepted and then shipping damage is found, please follow the specific instructions advised by the retailer.

- In all circumstances please save all packaging material and paperwork for the order.

- Please be aware that if you dispose of packaging material or attempt to return the merchandise without contacting the fulfiller, you jeopardise your chances of making a claim, and you may not receive a credit for the return.