

Full Bed

Assembly Instructions

1 Assembled View

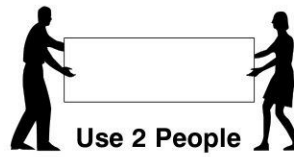
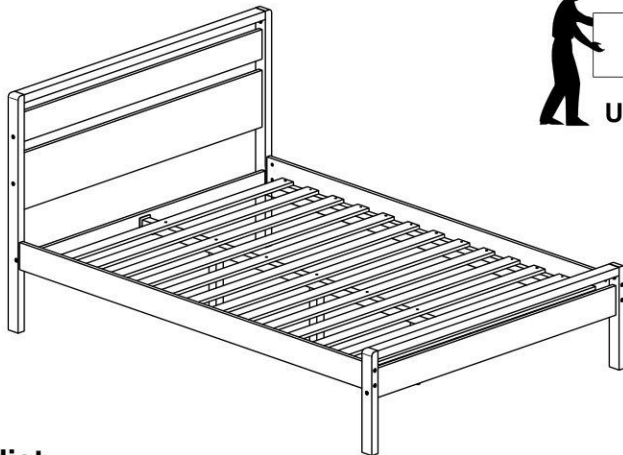

Note: Do not assemble using power tools. This can cause the bolts to be overtightened

2 Parts list

Parts in Box A:



Holes for Footboard Support Bar

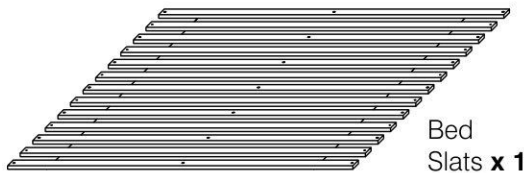
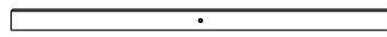

Parts in Box B:

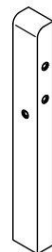
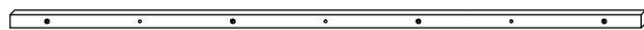

3 Hardware list



M6 x 100mm JCB
x 3



M6 x 40mm JCB
x 18



M6 x 15mm JCB
x 12



M6 x 90mm JCB
x 8

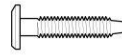

M6 x 30mm JCB
x 2



Barrel Nut
x 19



M6 x 70mm JCB
x 8

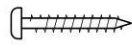

M4 x 32mm
Wood Screws
x 12

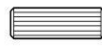

Wood Dowels
(M10 x 40mm)
x 14



'L' Bracket
x 4

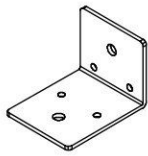

Center Rail Bracket
x 2

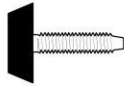

Adjustable Foot
x 3



Allen Key
x 1

4 Fix the Adjustable foot to the bottom of the Support Legs.

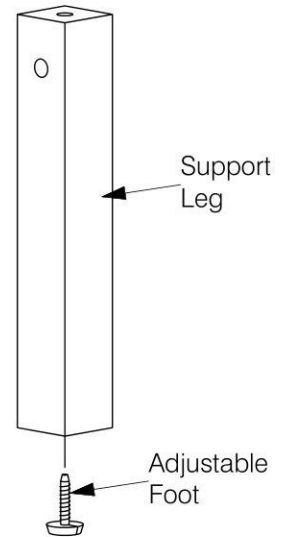

5 Fit the 'L' Bracket to the bottom of the Top Cap.

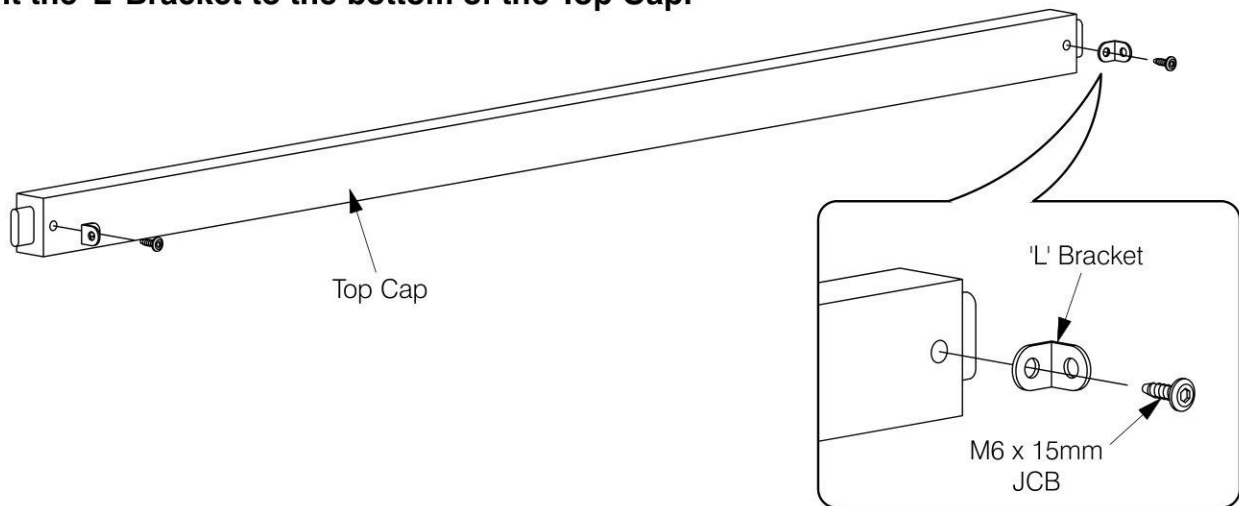

6 Fix the Footboard Support Bar to the Footboard Bottom Panel.

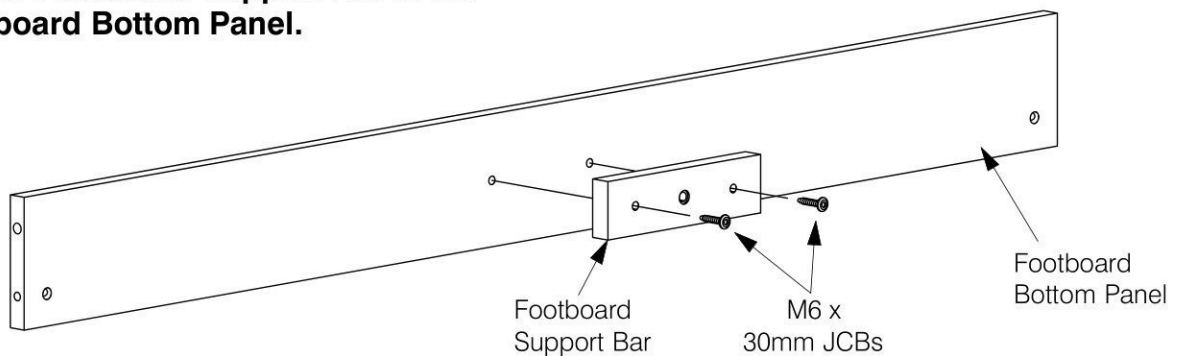

7 Assemble the Panels to the Footboard Post.

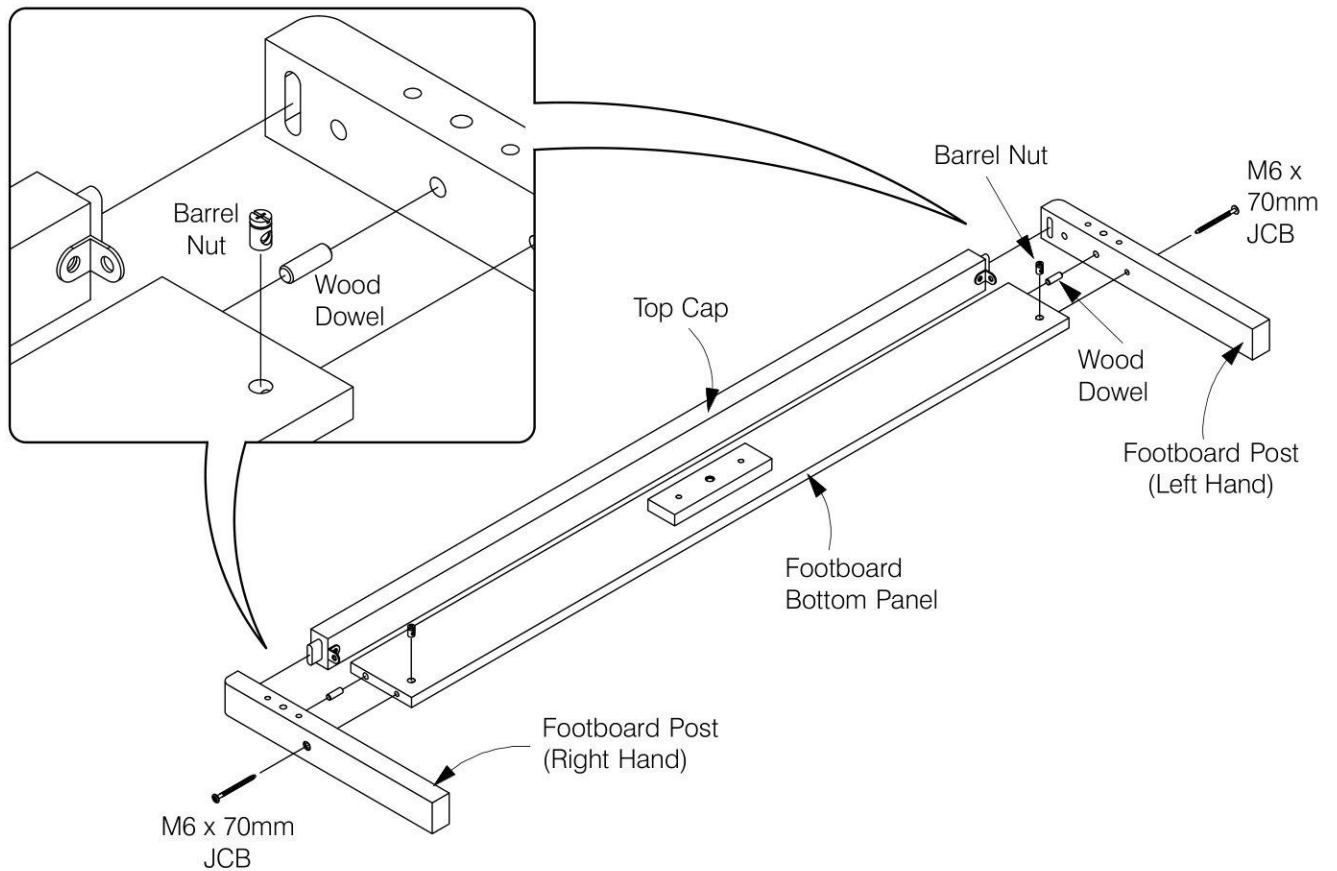

8 Bolt the 'L' Bracket to the Footboard Post. Fit the Center Rail Bracket to the Footboard Bottom Panel.

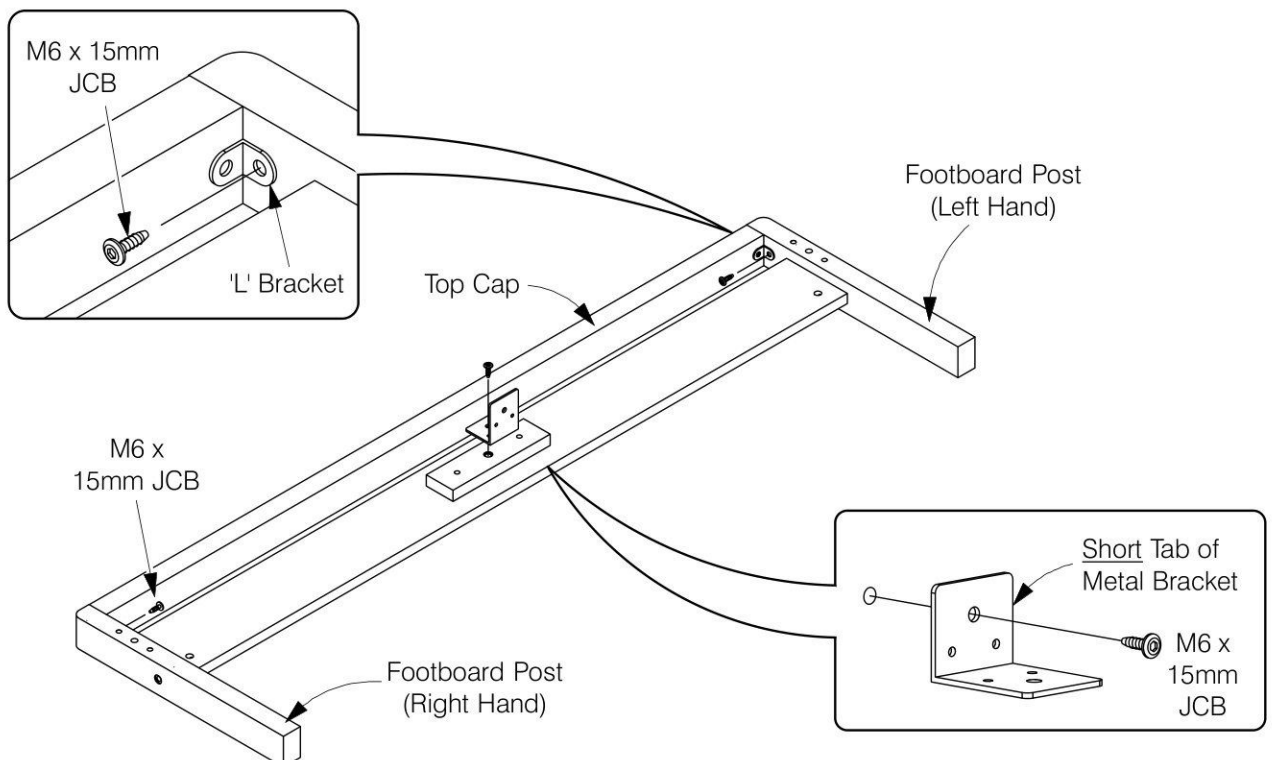

9 Assemble the Panels to the Headboard Post.

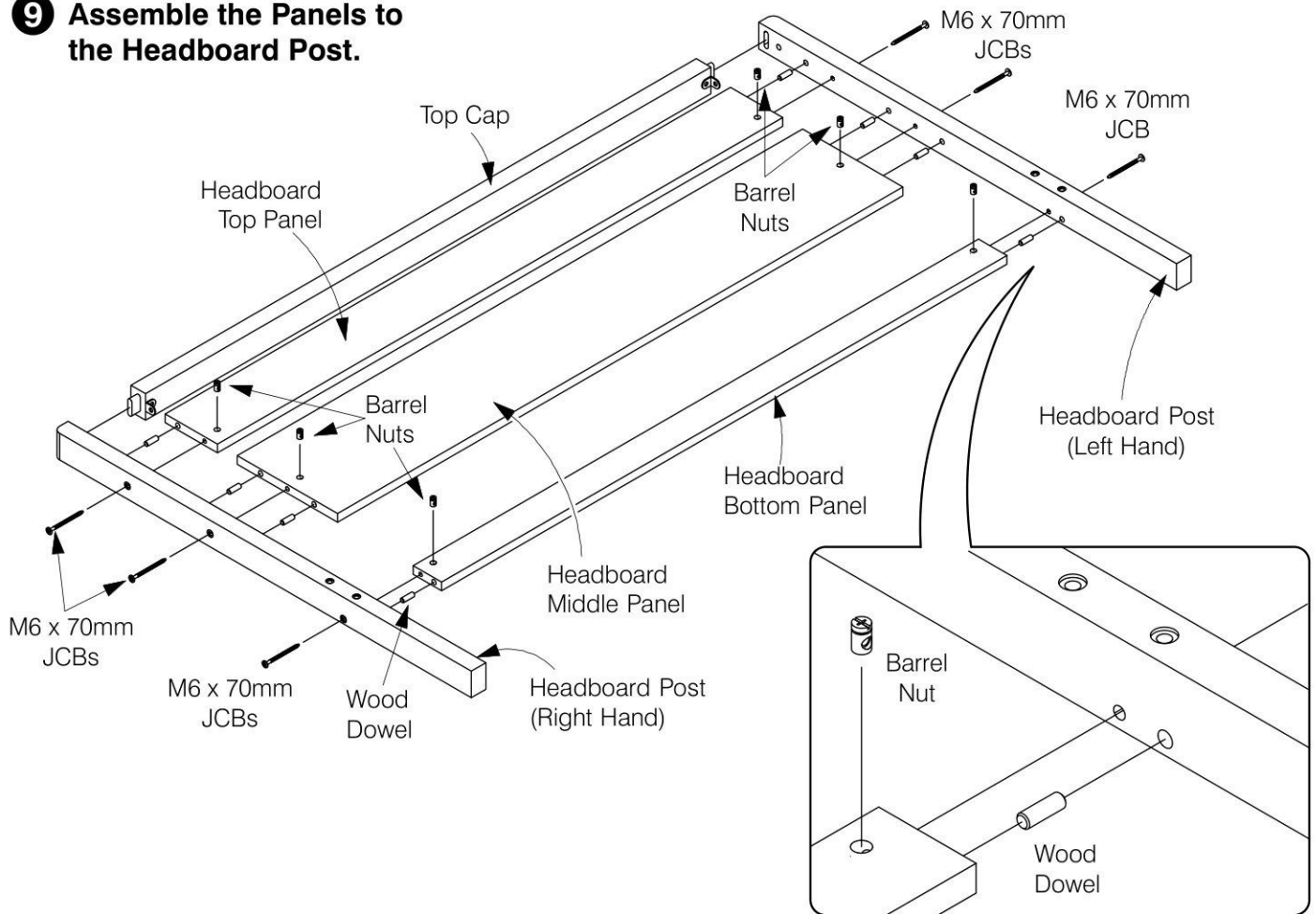

10 Bolt the 'L' Bracket to the Headboard Post. Fit the Center Rail Bracket to the Headboard Bottom Panel.

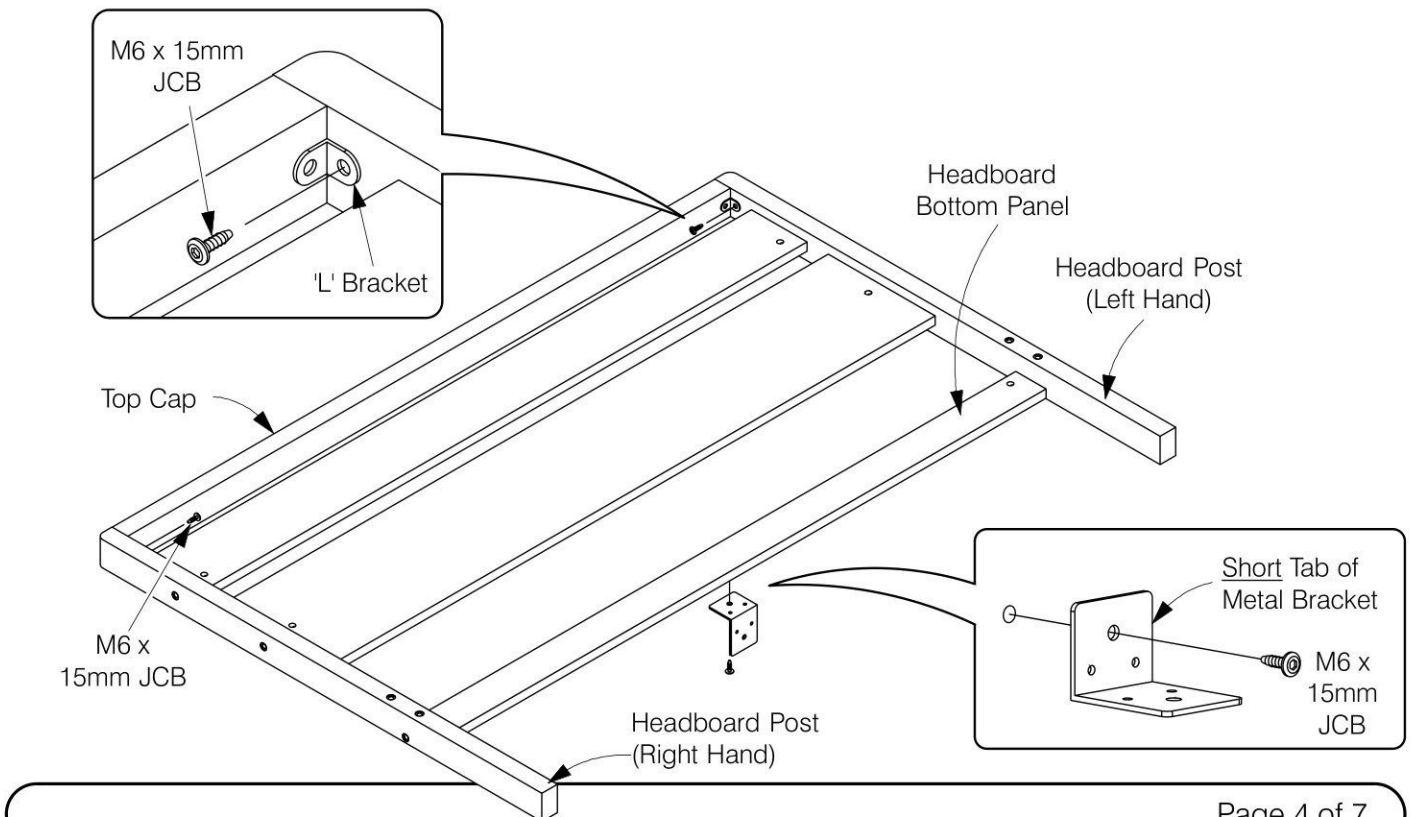

11 Attach the Side Rails to the Headboard and Footboard.

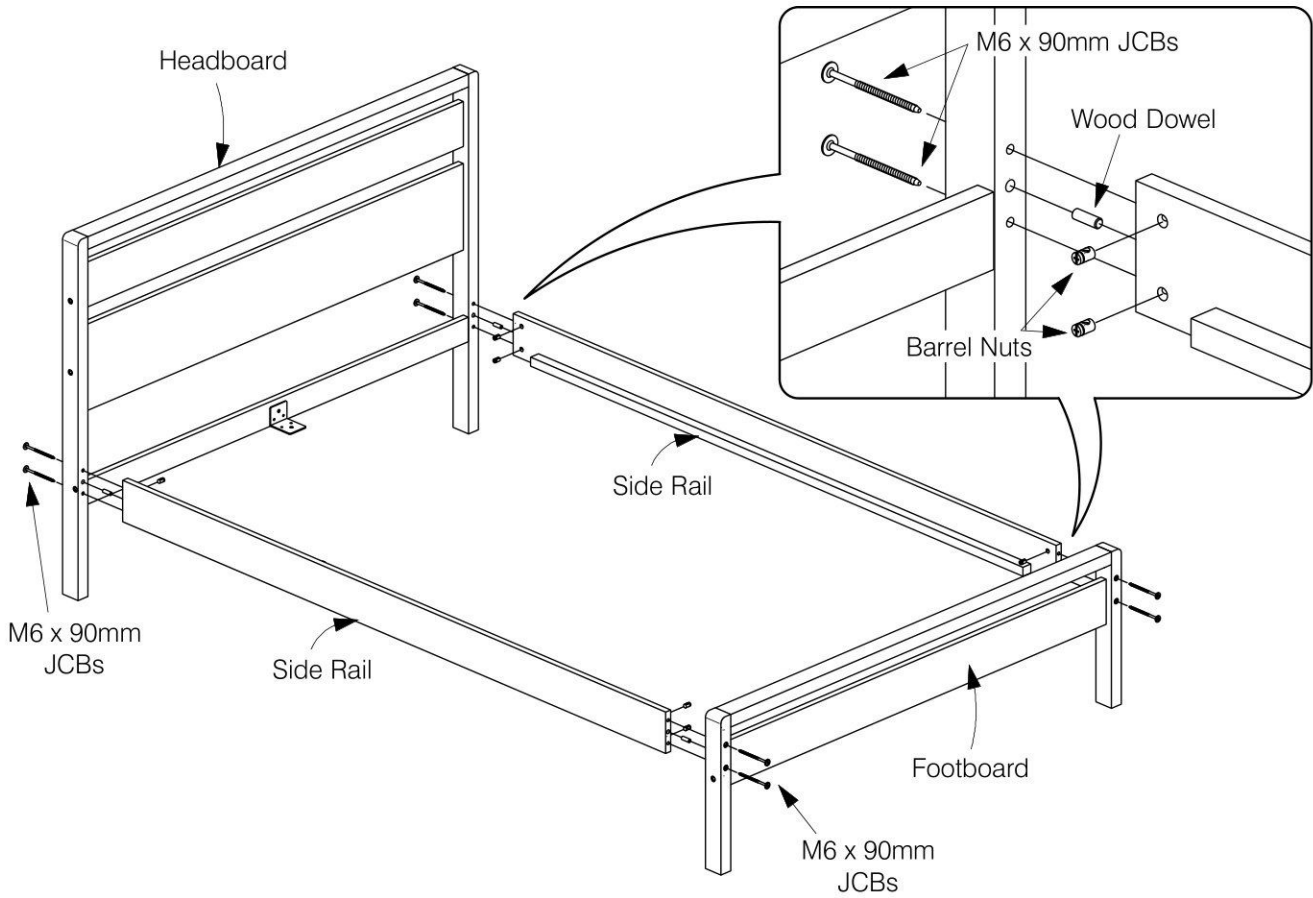

12 Bolt the Long Support to the Center Rail Brackets on the Head & Footboard.

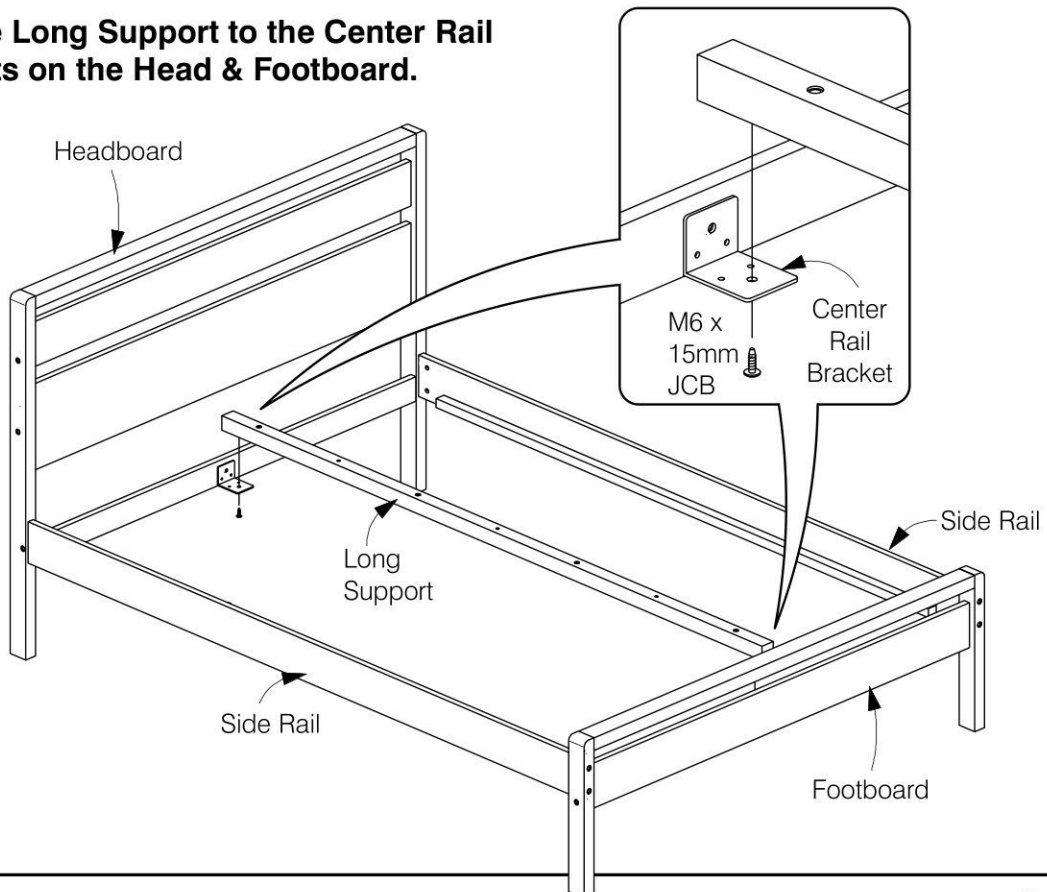

- 13** Fit the first 3 Slats and assemble the Support Leg to the Bed Slats. Bolt & screw the Bed Slats to the Side Rail & Long Support.

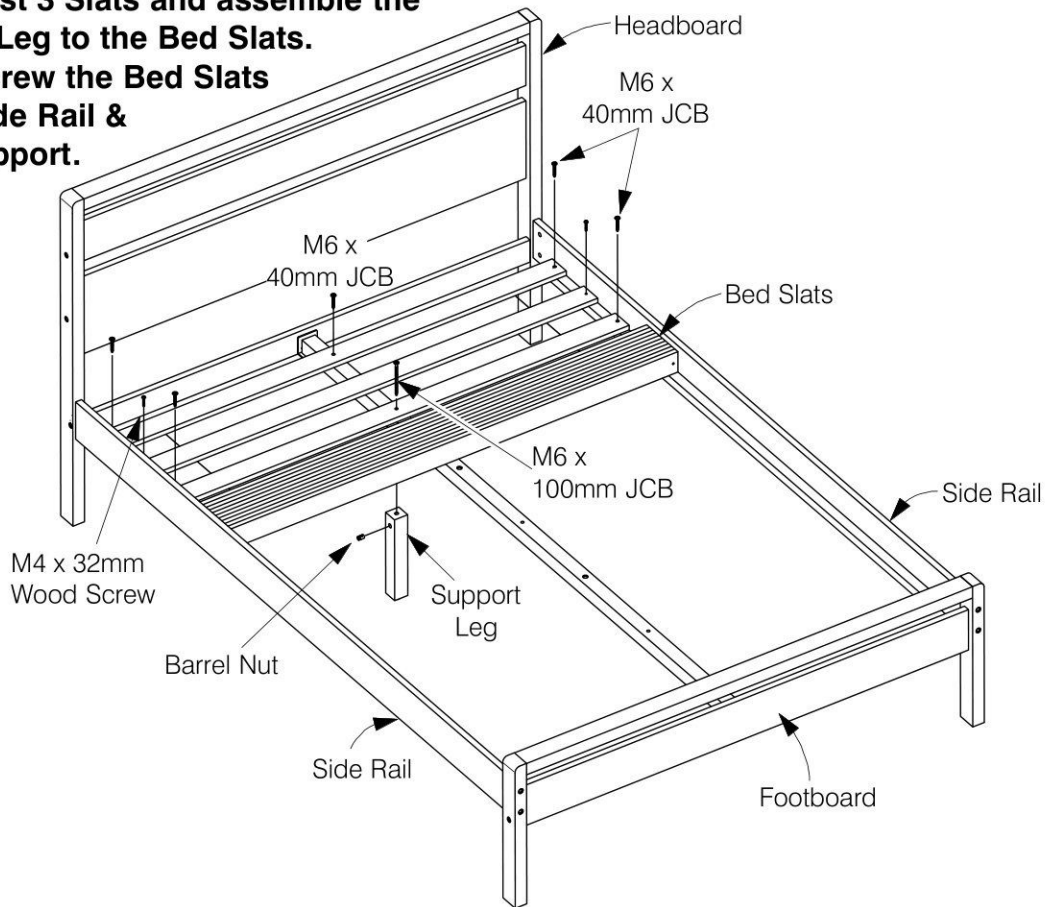

- 14** Fit the other Slats out and assemble the Support Leg to the Bed Slats. Bolt & screw the Bed Slats to the Side Rail & Long Support.

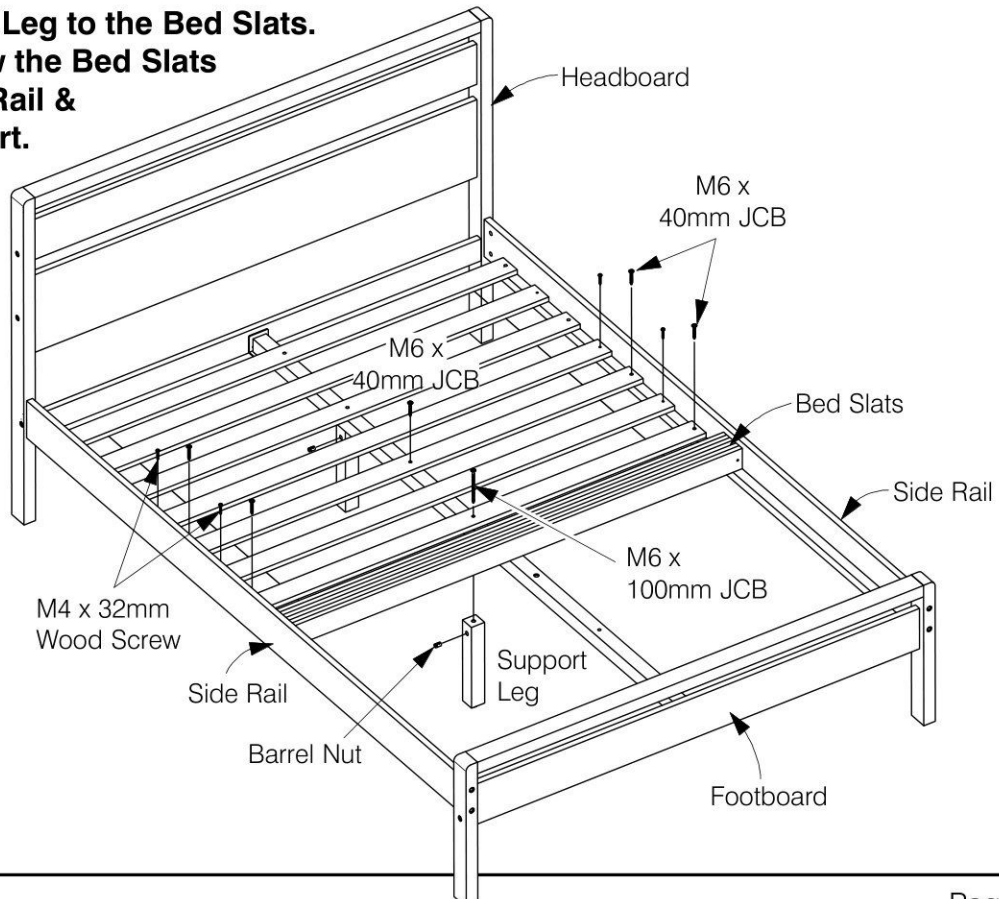

- 15** Fit the other Slats out and assemble the Support Leg to the Bed Slats. Bolt & screw the Bed Slats to the Side Rail & Long Support.

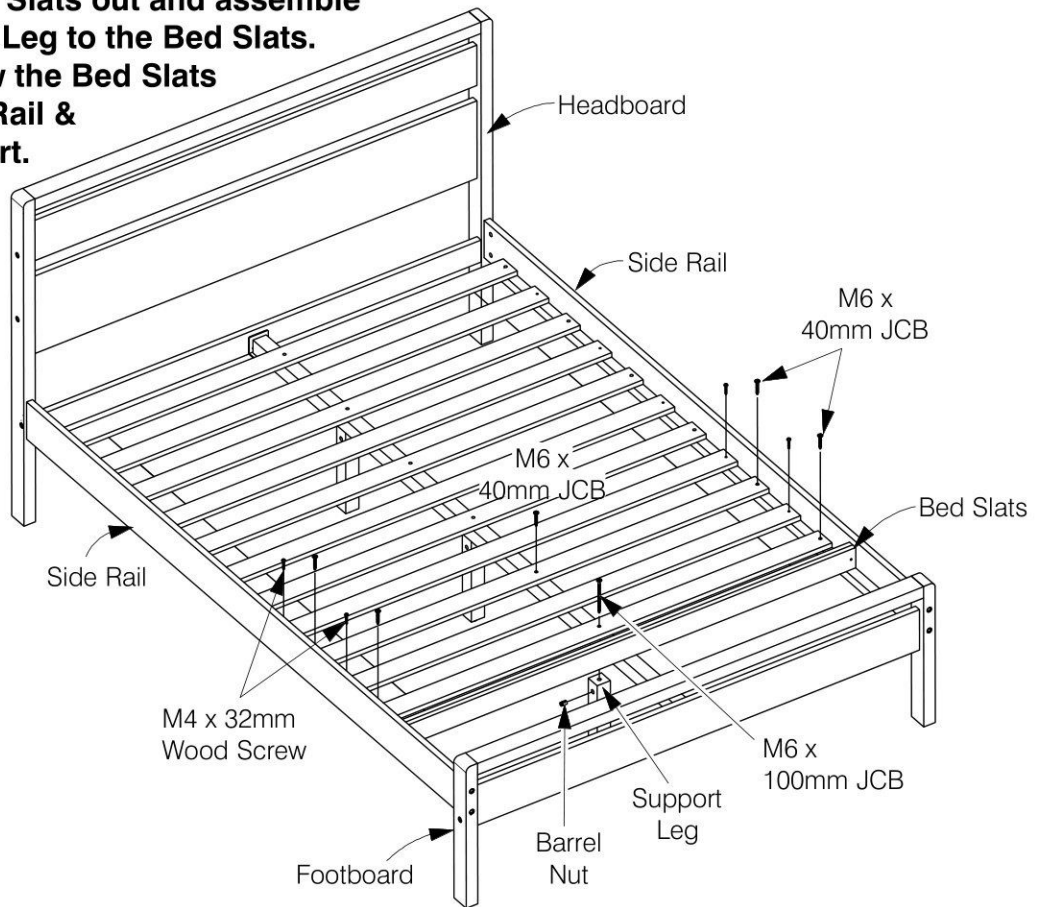

- 16** Bolt & screw the remaining Bed Slats to the Side Rail.

