

SKU:KHD-DX-T06

SKU:KHD-DC-T06

SKU:KHD-DC-T06-A2

Lot No.:DX-NO.2



## Assembly Guide

### Tip!

Do check for all the components and screws listed in this guide before putting things together. If any part is missing, contact us at support@vecelo.com ( US / CA ) or support-euteam@vecelo.com ( EU ) for the missing part.

### Return Policy

Your satisfaction is our top priority. If our product fails to satisfy you, please let us know how we can make things right for you. Our trained customer care team can handle most concerns and assist you with any questions you may have. Simply shoot them a message at support@vecelo.com(US/CA) or support-euteam@vecelo.com(EU) with your order number and question. To be eligible for a full-refund return, the item must be in pristine condition, in the original packaging, with all of the shipped components intact and not yet assembled, and with the item's unique proof of purchase.

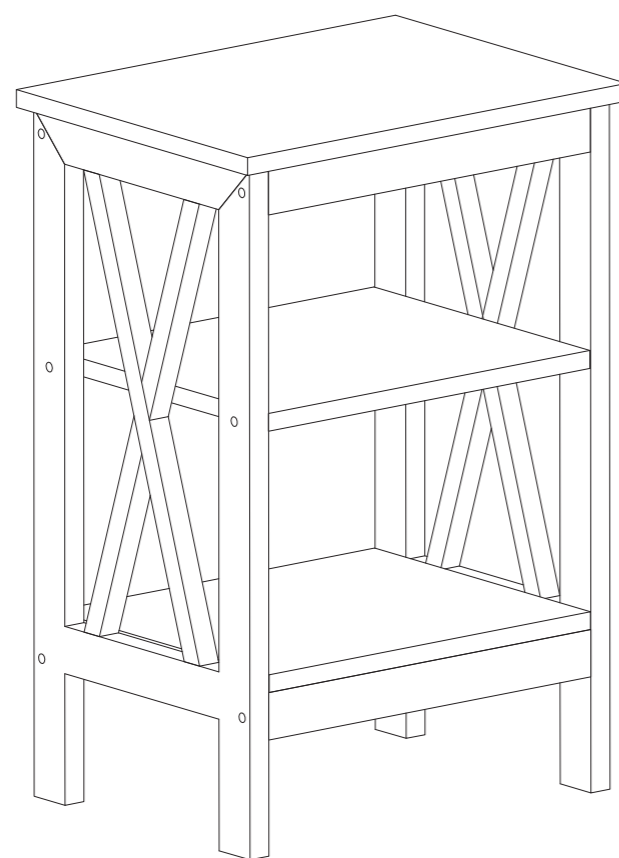

### Trouble shooting:

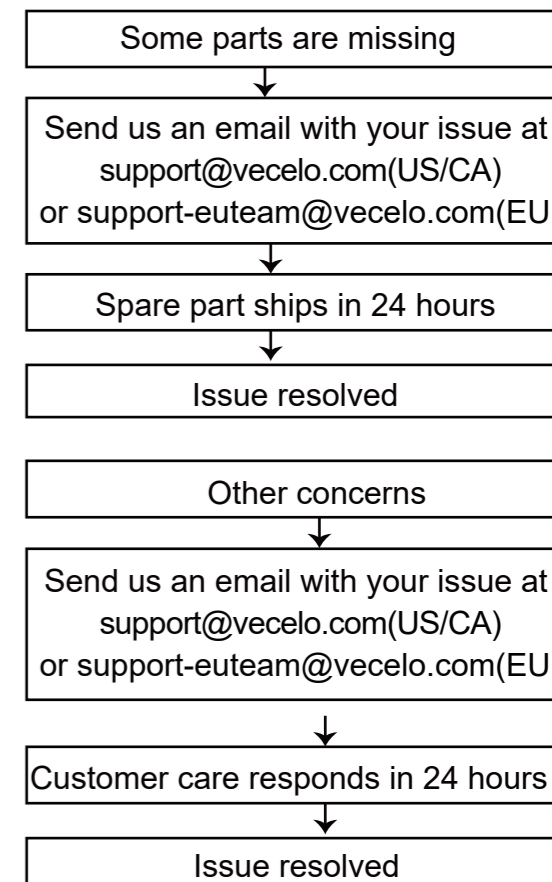

We run our own manufacturer, so rest assured about the quality consistency.

## CONTACT US

KONTAKTIEREN SIE UNS

NOUS CONTACTER

CONTATTACI

CONTACTENOS

E-mail: [support@vecelo.com](mailto:support@vecelo.com) ( US/CA )

E-mail: [support-euteam@vecelo.com](mailto:support-euteam@vecelo.com) ( EU/FR/DE/ES/IT )

Website: [www.vecelo.com](http://www.vecelo.com)

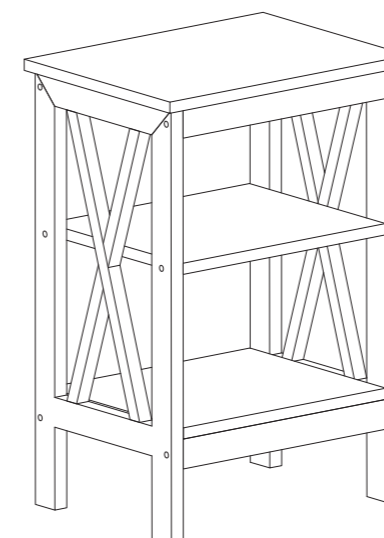

Item Description:     Night Stand    

Model NO:           DX-NO.2



## Montageanleitung

### Tipp!

ÜBERPRÜFEN Sie alle in dieser Anleitung aufgeführten Komponenten und Schrauben, bevor Sie die Bauteile zusammenbauen. Sollte ein Bauteil fehlen, kontaktieren Sie uns unter [support-euteam@vecelo.com](mailto:support-euteam@vecelo.com) um Ersatz zu erhalten.

### Rückgaberrichtlinie

Ihre Zufriedenheit ist unsere oberste Priorität. Wenn Sie mit unserem Produkt nicht zufrieden sind, lassen Sie uns bitte wissen, wie wir die Angelegenheit für Sie in Ordnung bringen können. Unser geschultes Kundenbetreu kann die meisten Anliegen lösen und unter Sie bei allen Ihren Fragen. Senden Sie uns einfach eine Nachricht an [support-euteam@vecelo.com](mailto:support-euteam@vecelo.com) mit Ihrer Bestellnummer und Ihrer Frage. Um eine volle Rückerstattung zu erhalten, muss der Artikel in einwandfreiem Zustand sein und sich in der Originalverpackung mit allen gelieferten und noch nicht zusammengebaute Komponenten befinden. Zudem wird der eindeutige Kaufnachweis des Artikels.

SKU:KHD-DX-T06

SKU:KHD-DC-T06

SKU:KHD-DC-T06-A2

Lot No.:DX-NO.2

Problemlösung:

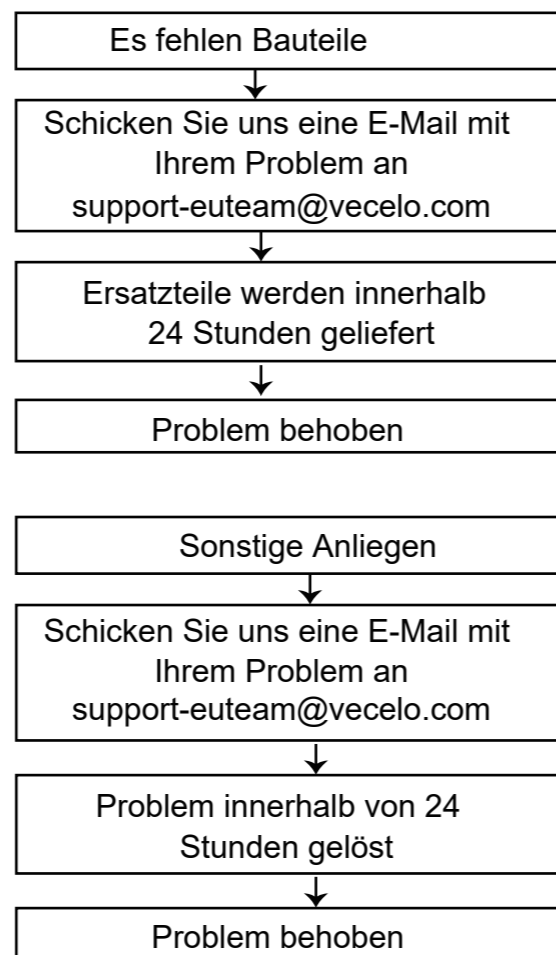

Wir stellen unsere Artikel selbst her, sodass Sie sich auf gleichbleibende Qualität verlassen können.

## Step 5

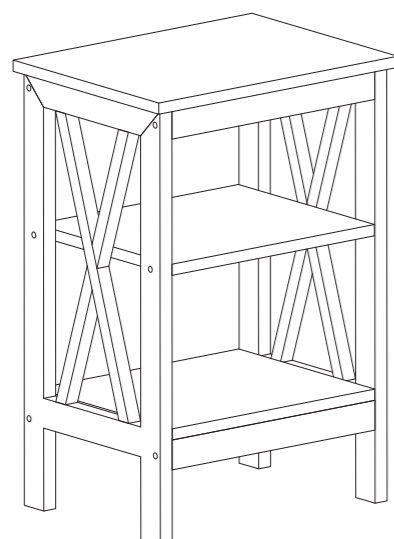
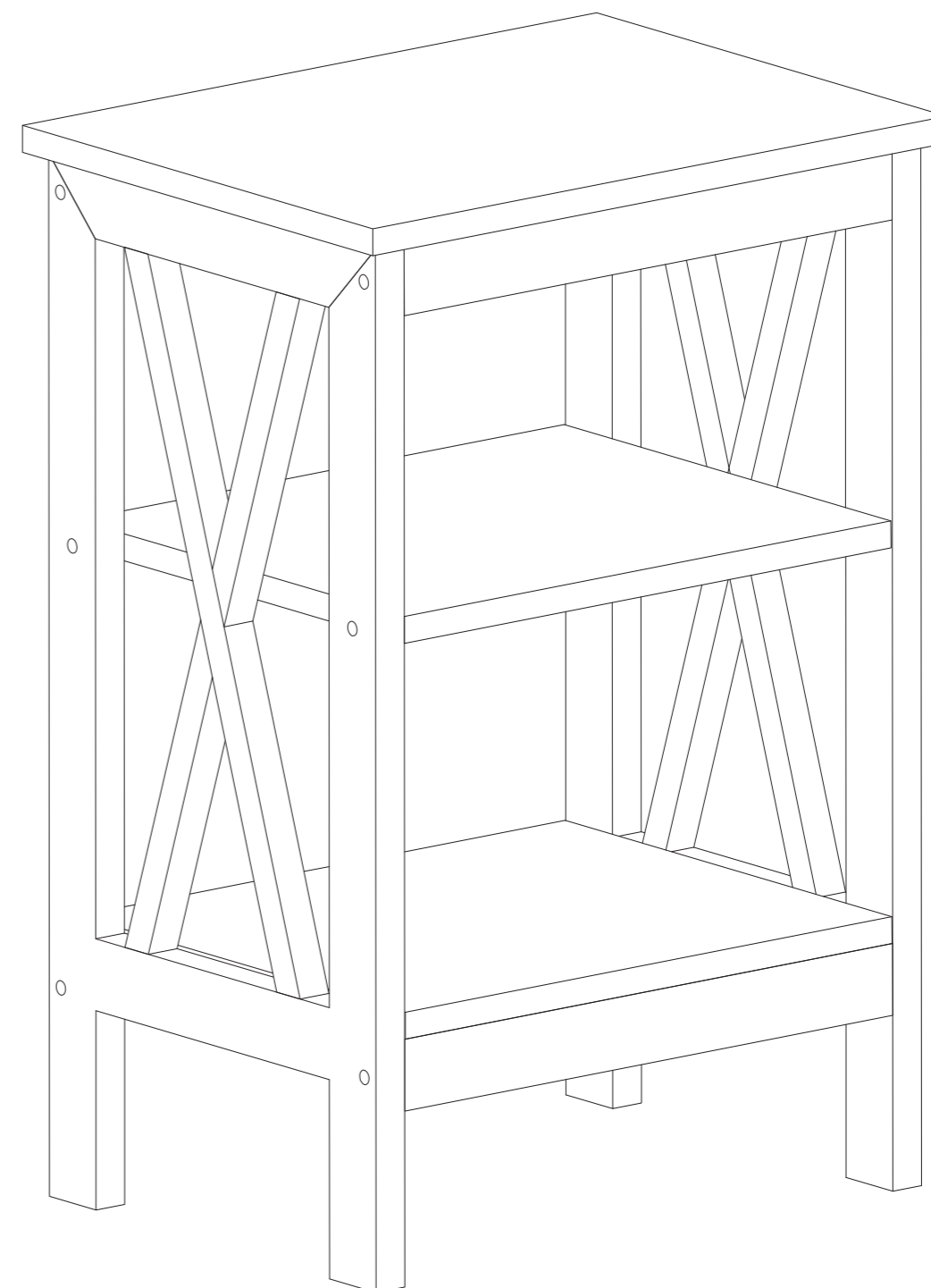

Item Description: Nachttisch

Model NO: DX-NO.2

## Step 4

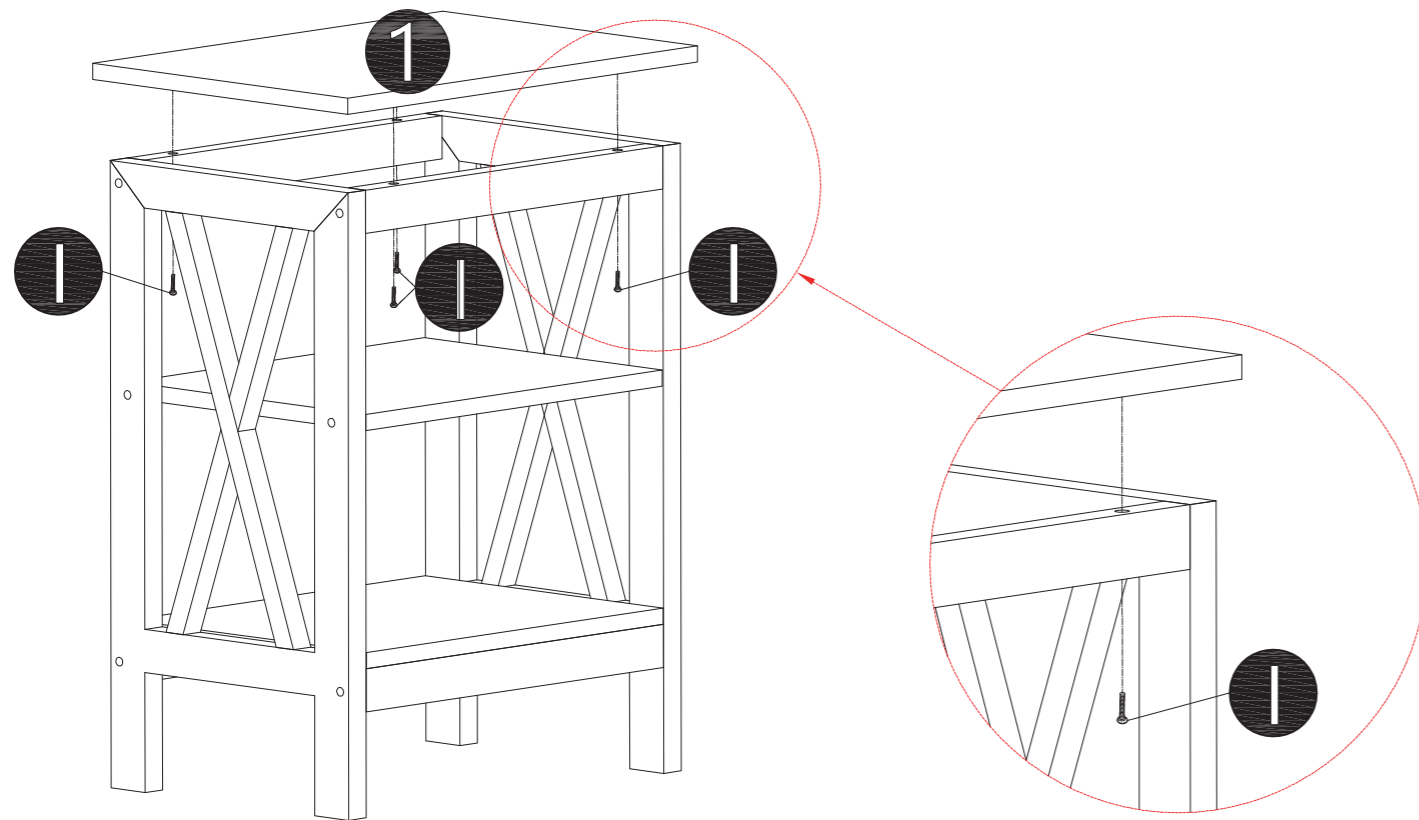
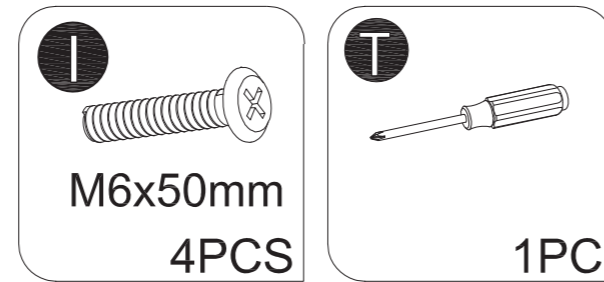

## Guide de montage

### Attention !

VÉRIFIEZ la présence de l'ensemble des éléments et vis énumérés dans ce guide avant de procéder au montage. Si une pièce venait à manquer, envoyez-nous un e-mail à [support-euteam@vecelo.com](mailto:support-euteam@vecelo.com) pour nous le signaler.

### Politique de retour

Votre satisfaction est notre priorité absolue. Si notre produit ne vous donne pas entière satisfaction, n'hésitez pas à nous faire savoir ce que nous pouvons faire pour améliorer la situation. Notre équipe d'assistance à la clientèle qualifiée est en mesure de résoudre la plupart de vos problèmes et de répondre à toutes vos questions. Il vous suffit de leur envoyer un message à l'adresse [support-euteam@vecelo.com](mailto:support-euteam@vecelo.com) en indiquant votre numéro de commande et votre question. Pour pouvoir bénéficier d'un remboursement intégral, l'article doit être en parfait état, dans son emballage d'origine, avec tous les composants expédiés intacts et non encore assemblés, et avec la preuve d'achat unique de l'article.

SKU:KHD-DX-T06

SKU:KHD-DC-T06

SKU:KHD-DC-T06-A2

Lot No.:DX-NO.2

Dépannage :

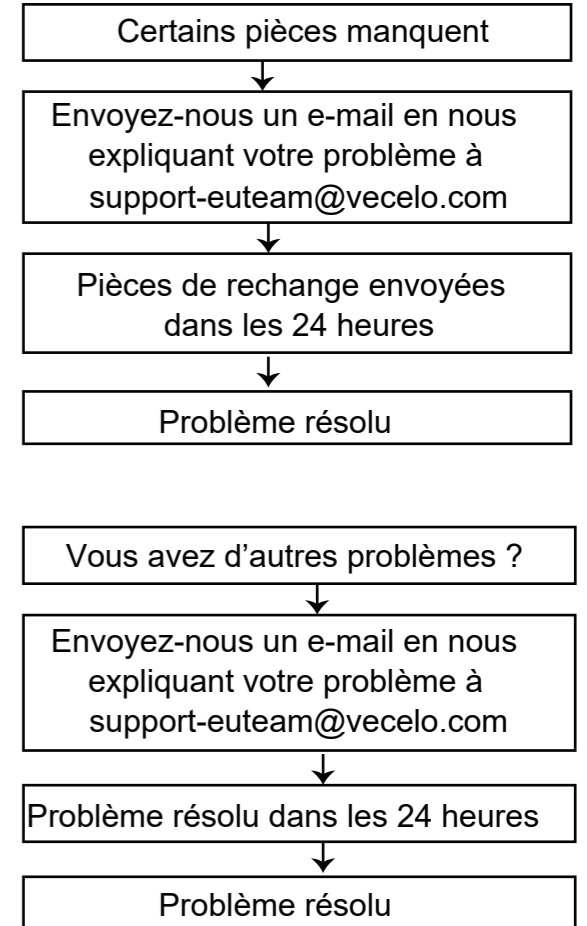

Nous assurons notre propre fabrication, donc soyez assuré de bénéficier d'une qualité constante.

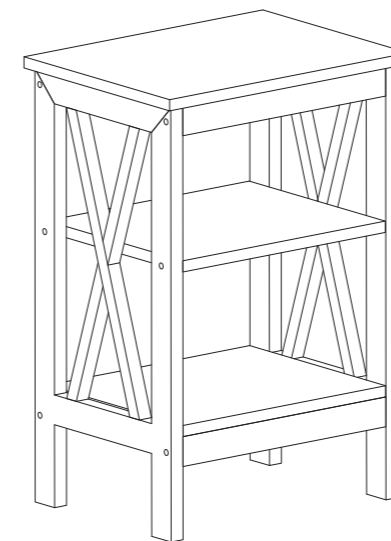

Item Description: Table de nuit

Model NO: DX-NO.2

## Guida all'assemblaggio

### Mancia!

Controllare tutti i componenti e le viti elencati in questa guida prima di inserire le cose insieme. Se manca qualche parte, contattaci a support-euteam@vecelo.com per i dispersi parte.

### Politica di ritorno

La vostra soddisfazione è la nostra massima priorità. Se il nostro il prodotto non ti soddisfa, faccelo sapere come possiamo sistemare le cose per te. Nostro un team di assistenza clienti qualificato può gestire la maggior parte preoccupazioni e assistervi per qualsiasi domanda tu forse hai. Invia loro semplicemente un messaggio a support-euteam@vecelo.com con il tuo numero d'ordine e domanda. Essere eleggibile per un reso con rimborso completo, l'articolo deve essere presente ottime condizioni, nella confezione originale, con tutti i componenti spediti intatti e non ancora assemblato e con l'oggetto unico prova d'acquisto.

Risoluzione dei problemi:

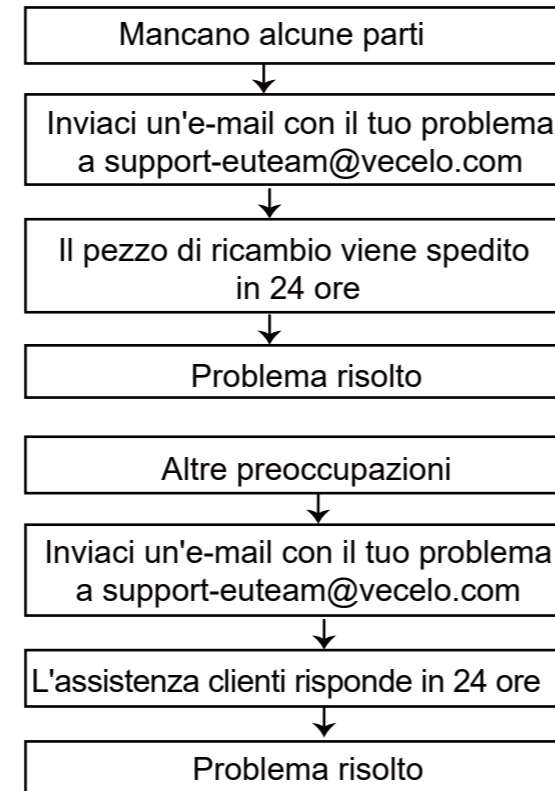

Gestiamo il nostro produttore, quindi riposati assicurato circa la consistenza di qualità.

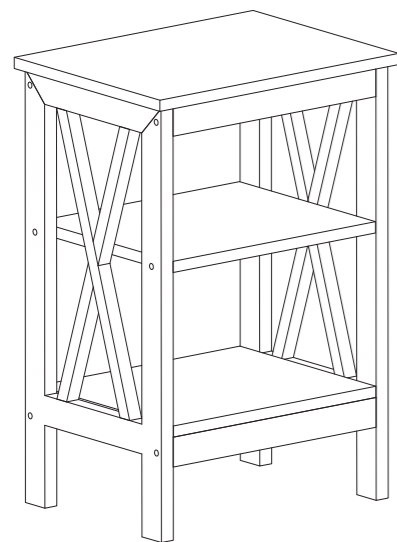

Descrizione dell'articolo: Comodino

Modello NO: DX-NO.2

## Step 1

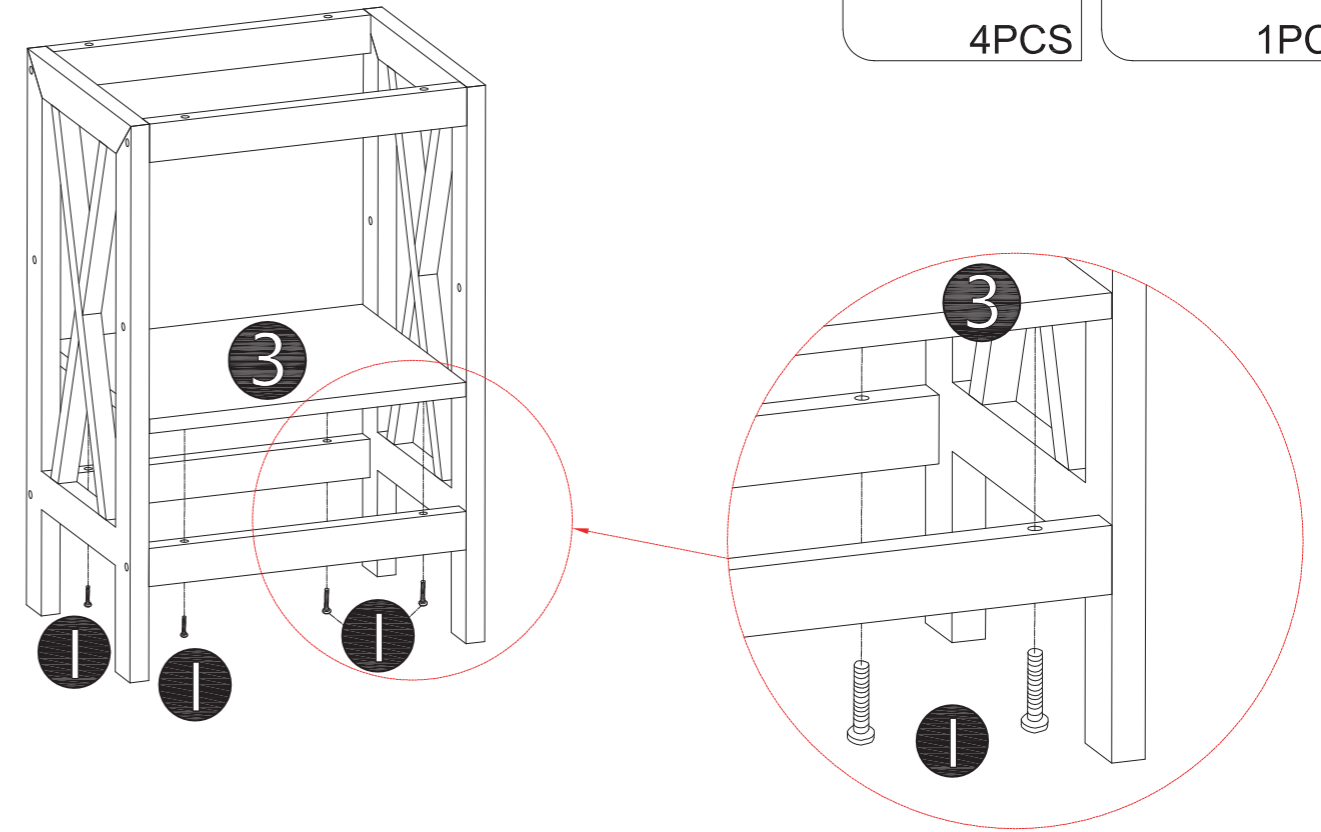
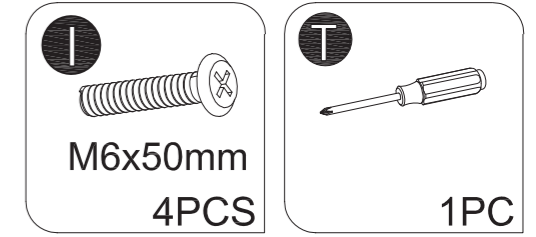

## Step 3

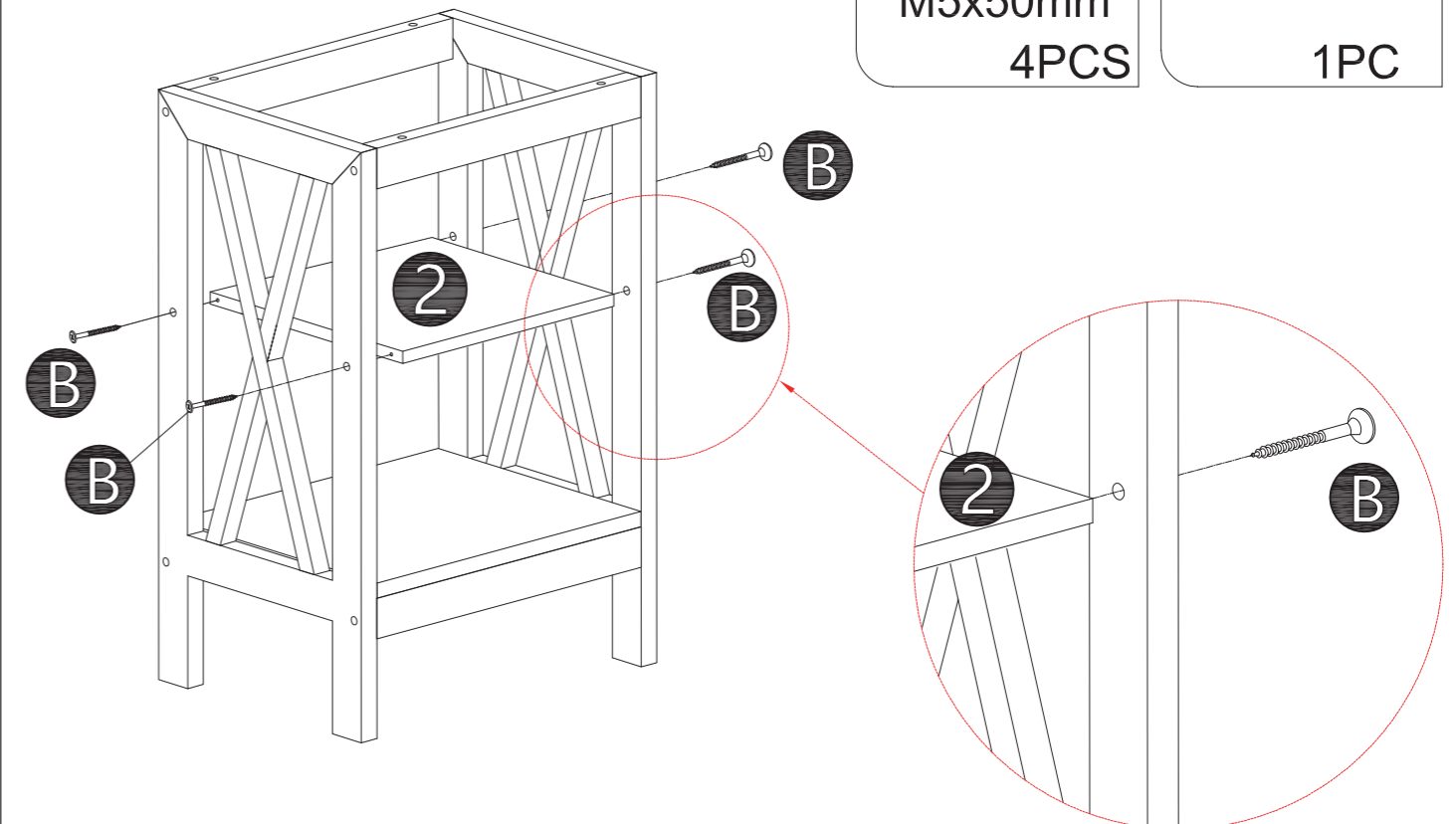
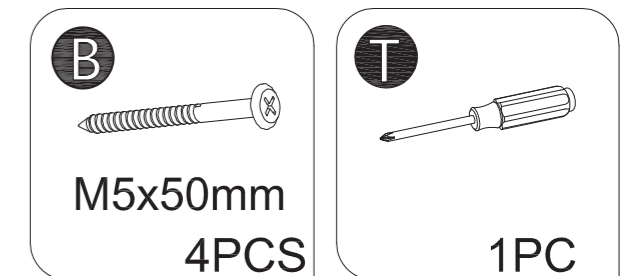

# Step 1

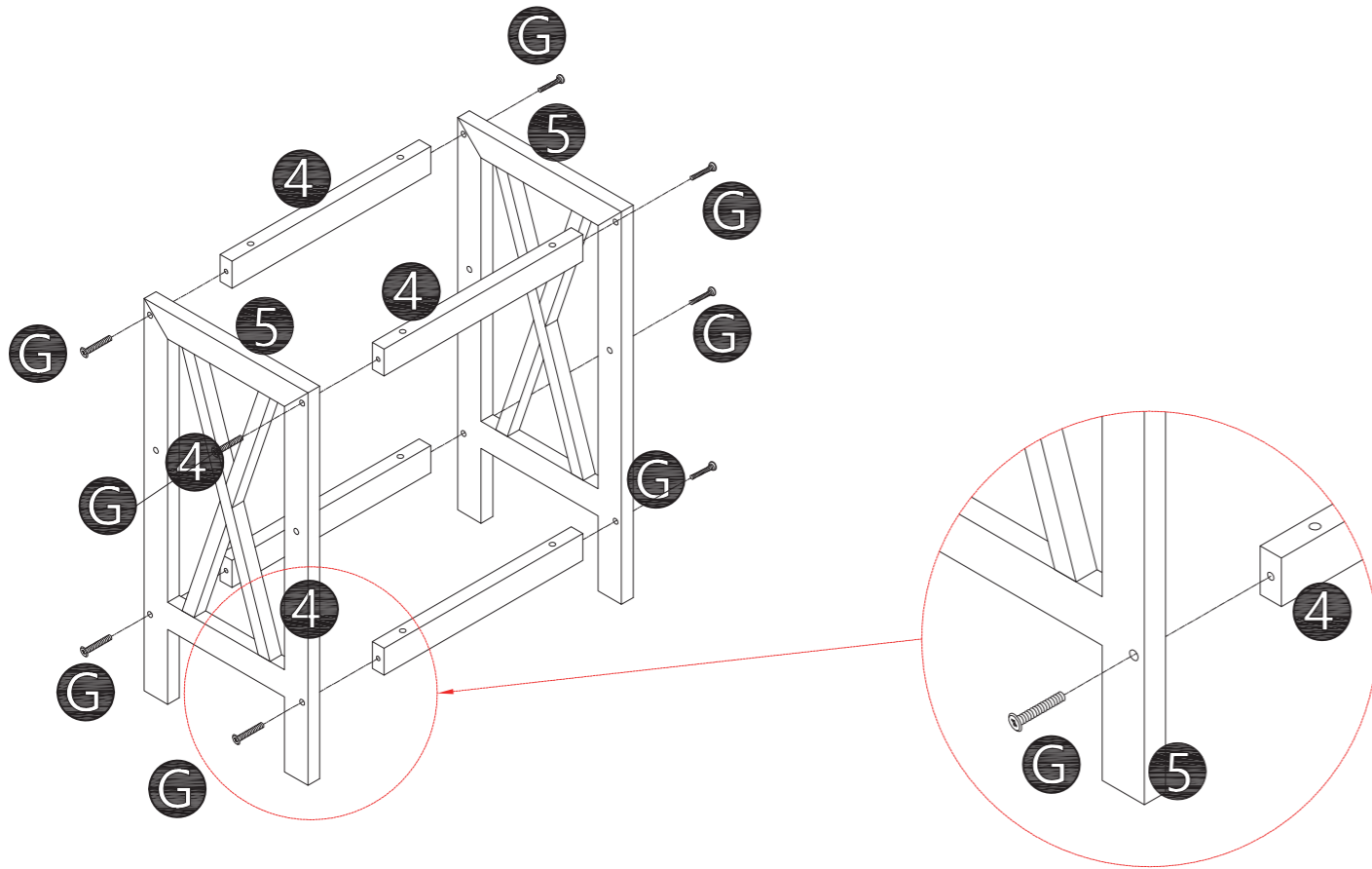
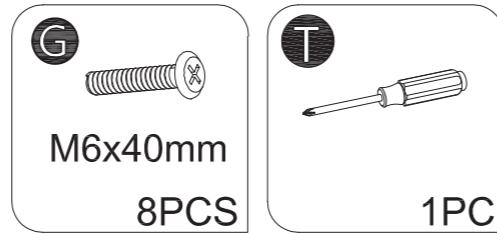

## Guía de montaje

### Consejo!

Verifique todos los componentes y tornillos. Enumerados en esta guía antes de poner las cosas juntas. Si falta alguna pieza, contáctanos al support-euteam@vecelo.com por los desaparecidos parte.

### Política de devoluciones

Su satisfacción es nuestra máxima prioridad. Si nuestro el producto no le satisface, háganoslo saber. CÓMO podemos hacer las cosas bien para usted. Nuestro equipo de atención al cliente capacitado puede manejar la mayoría inquietudes y ayudarle con cualquier pregunta es posible que tengas. Simplemente envíales un mensaje en support-euteam@vecelo.com con su número de pedido y pregunta. Ser elegible para una devolución con reembolso completo, el artículo debe estar en impecable estado, en el embalaje original, con todos los componentes enviados intactos y aún no ensamblado y con la característica única del artículo. Comprobante de compra.

SKU:KHD-DX-T06

SKU:KHD-DC-T06

SKU:KHD-DC-T06-A2

Lot No.:DX-NO.2

### Solución de problemas:

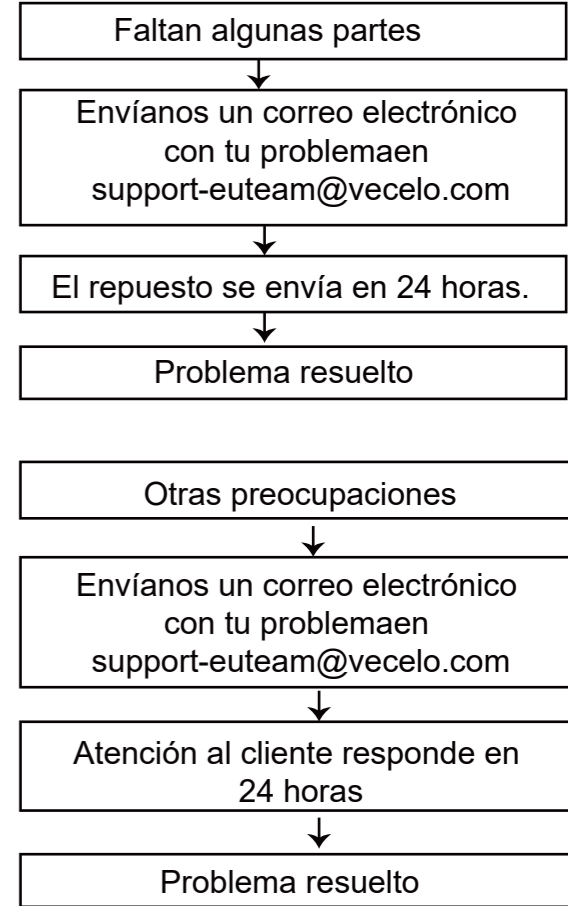

Dirigimos nuestro propio fabricante, así que descansa. Asegurado sobre la consistencia de la calidad

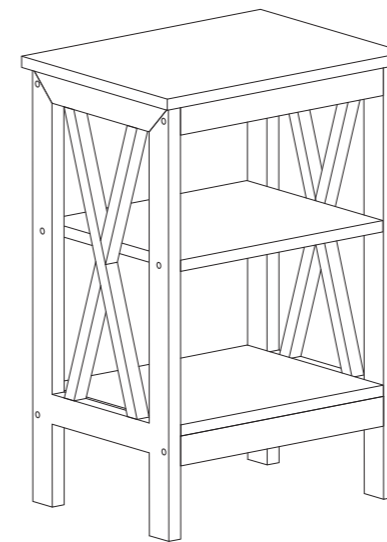

Descripción del artículo:           Mesita de noche          

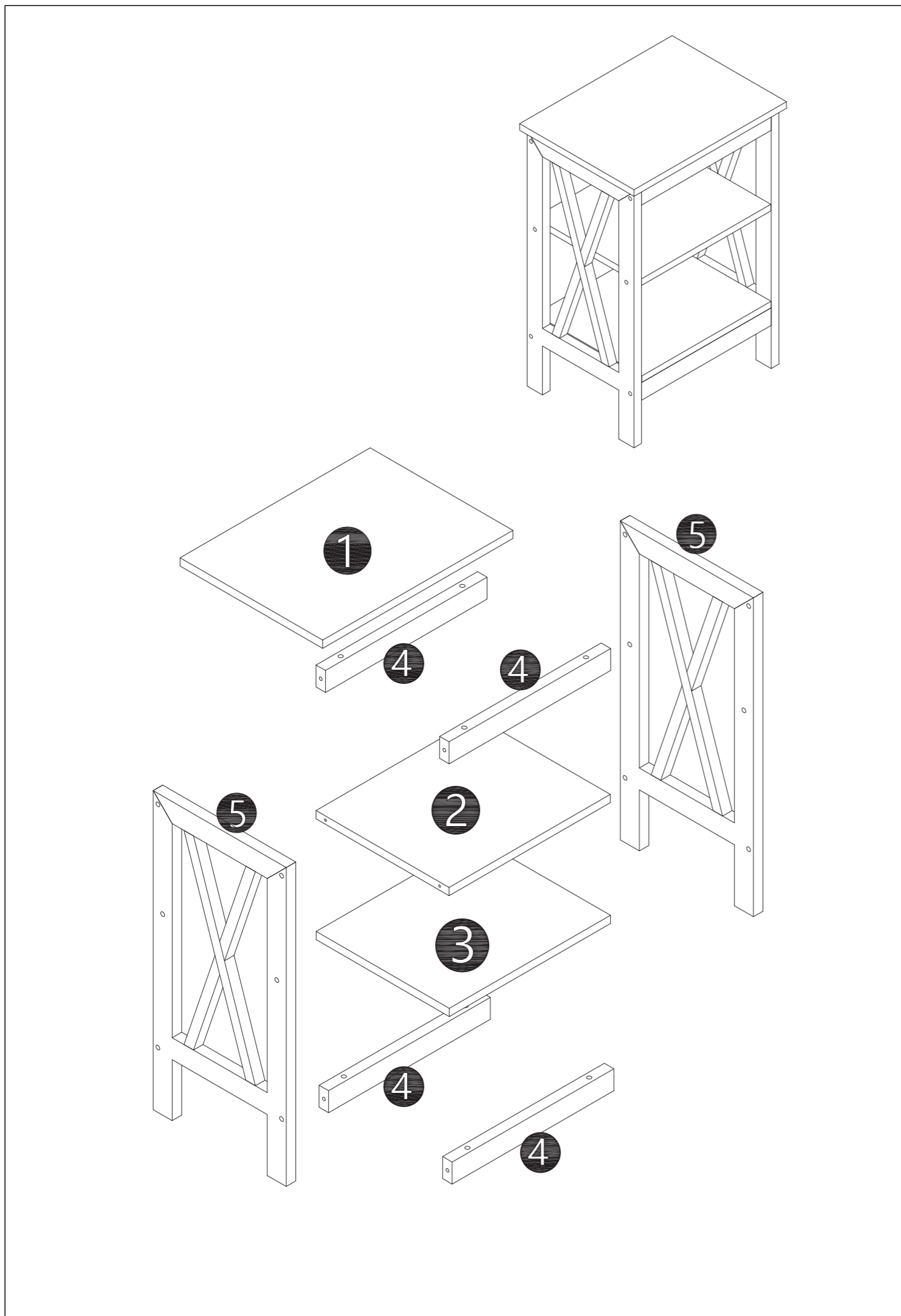

Modelo NO:   DX-NO.2

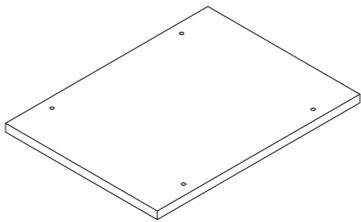
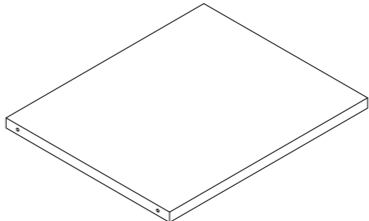
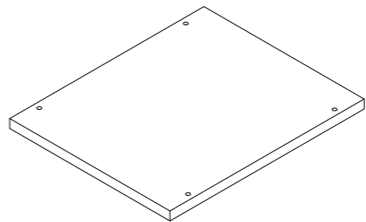
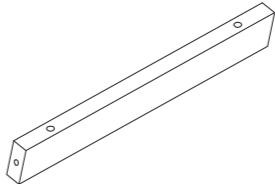
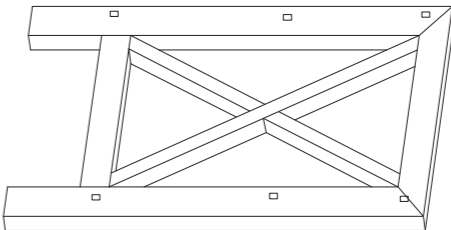

Components / Bauteile / Composants / Componenti / Componentes /

<b>1</b>		400×300mm	1
<b>2</b>		339×280mm	1
<b>3</b>		339×280mm	1
<b>4</b>		20×40×340mm	4
<b>5</b>		584×280mm	2

Screws & Tools / Schrauben und Werkzeuge / Vis et outils / Viti e utensili / Tornillos y Herramientas /

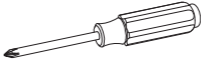
<b>B</b>		M5x50mm	4
<b>G</b>		M6x40mm	8
<b>I</b>		M6x50mm	8
<b>T</b>			1