

KITCHEN ISLAND CARTS

Assembly Instructions - Please keep for future reference

SKU: N707P423691/N707P423692

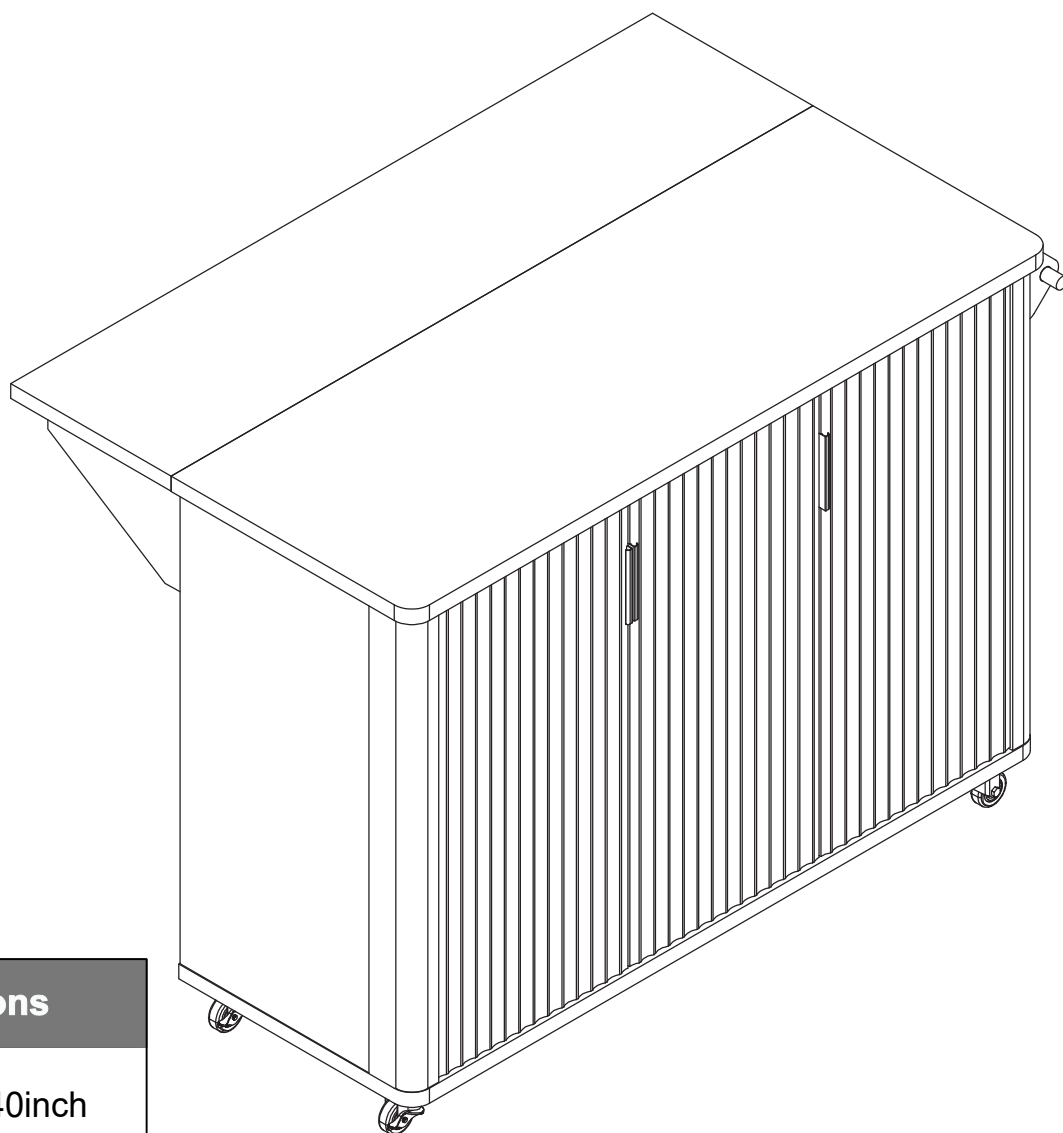

Dimensions

Width-47.40inch

Depth-29.32inch

Height-37.64inch

Important – Please read these instructions fully before starting assembly



Safety and Care Advice

Important – Please read these instructions fully before starting assembly

- Check you have all the components and tools listed on the following pages.

- Remove all fittings from the plastic bags and separate them into their groups.

- Keep children and animals away from the work area, small parts could choke if swallowed.

- Make sure you have enough space to layout the parts before starting.

- During assembly do not stand or put weight on the product, this could cause damage.

- Assemble the item as close to its final position (in the same room) as possible.

- Assemble on a soft level surface to avoid damaging the unit or your floor.

- Parts of the assembly will be easier with 3 people.

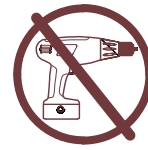

power drill is set on a low torque setting.

- To reduce the likelihood of damaging your product please ensure that your

Care and maintenance

- Only clean using a damp cloth and mild detergent, do not use bleach or abrasive cleaners.

- From time to time check that there are no loose screws on this unit.

- This product should not be discarded with household waste. Take to your local authority waste disposal centre.

Handy Hints

- Assemble all parts and bolts loosely during assembly, only once the product is complete should you fully tighten the bolts

- Regularly check and ensure That all bolts and fittings are tightend properly.

WARNING
In order to help prevent overturning – please follow these instructions













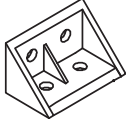

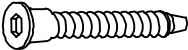
To help prevent product toppling over please follow the below steps:-

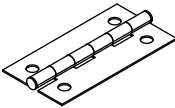
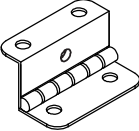
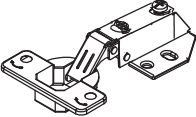
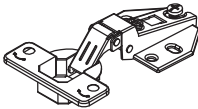
Use the anti tip stap or wall fixing method provided (if applicable)
Do not allow children to climb or hang on the furniture
Do not open more than one drawer at a time
Do not place heavy items in the top drawers
Do not place heavy items on top of the furniture, unless the furniture has been designed for this purpose

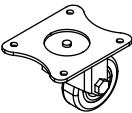
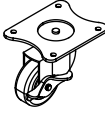
Components - Fittings

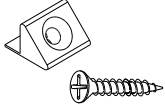
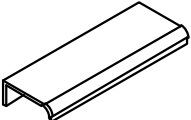
Please check you have all the panels listed below

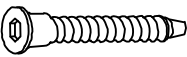
Note: The quantities below are the correct amount to complete the assembly. In some cases more fittings may be supplied than are required.

<p>A</p>  <p>15*12mm Cam lock x26</p>	<p>B</p>  <p>15*9.5mm Cam lock x26+2</p>	<p>C</p>  <p>6x40mm Dowel x 12</p>	<p>D</p>  <p>Angle iron x 2</p>
<p>E</p>  <p>3x12mm Screw x 62</p>	<p>F</p>  <p>7x40mm Screw x 4</p>	<p>G</p>  <p>3x14mm Screw x 40</p>	<p>H</p>  <p>x2</p>
<p>I</p>  <p>hinge x 3</p>	<p>J</p>  <p>hinge x 4</p>	<p>K</p>  <p>DWx2</p>	<p>L</p>  <p>ZMx4</p>
<p>M</p>  <p>6*25mm Screw x 16</p>	<p>N</p>  <p>Caster x 2</p>	<p>O</p>  <p>Locking caster x 2</p>	<p>P</p>  <p>Pivot x 8</p>
<p>Q</p>  <p>3*16mm Screw x 12</p>	<p>R</p>  <p>Hold hands x3</p>	<p>Y</p>  <p>3.5*30mm Screw x 16</p>	<p>U</p>  <p>7x50mm Screw x 8</p>
<p>X</p>  <p>Allen Wrench x 1</p>	 <p>Allen Wrench x 1</p>		

Tools required Not Included

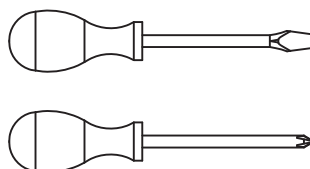
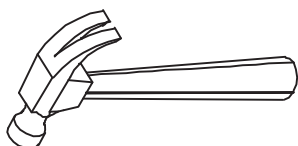

Phillips screwdriver
(medium & large)

Using Camlocks

Step 1

Connect the male camlock as directed in the assembly instructions using a screwdriver.

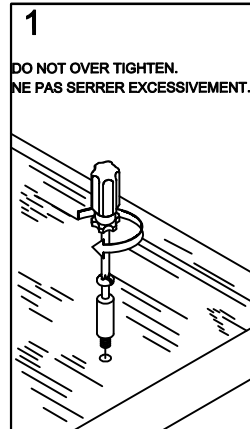

Step 2

Push the male camlock into the entry hole.

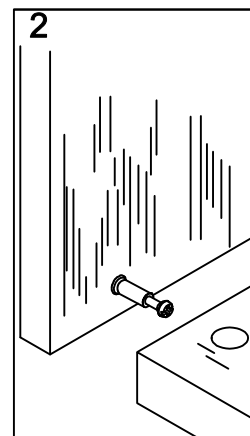

Step 3

Insert the female camlock as shown in the instruction.

Note: ensure that the arrow on the top of the camlock points towards the entry hole for the male camlock.

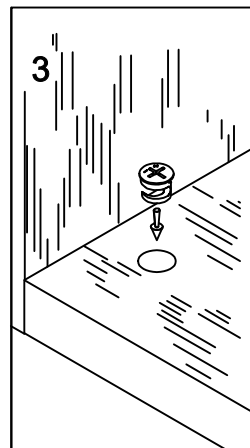

Step 4

Turn the female camlock clockwise with a screwdriver.

You should feel a click when the camlock is locked in place.

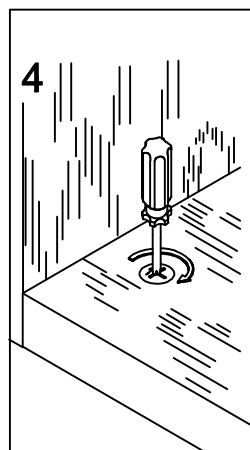

The joint is now secure.



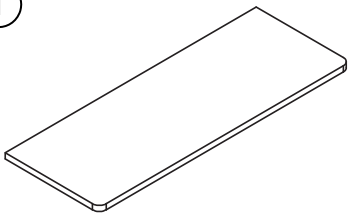
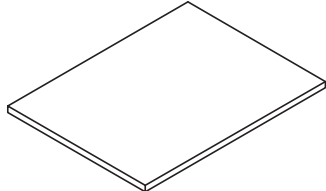
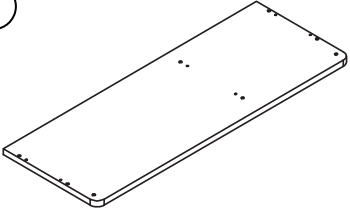

Components - Parts

Please check you have all the panels listed below.

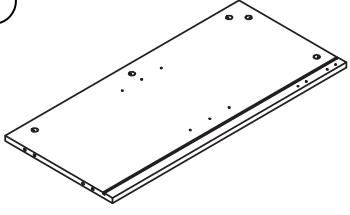
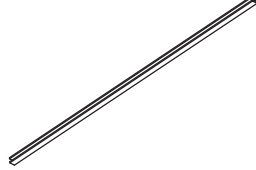
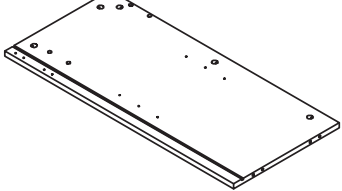
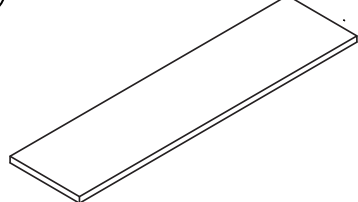
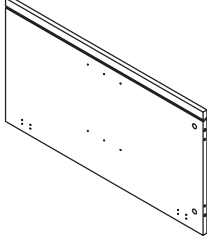
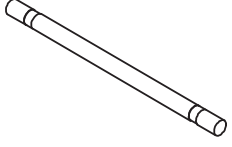
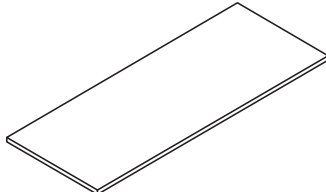
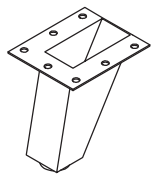
BOX A - N707P423691





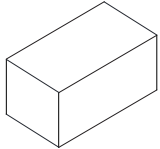

<p>①</p>  <p>1200 x 450 x 24mm</p> <p>1</p>	<p>⑦</p>  <p>393x300x12 mm</p> <p>1</p>
<p>②</p>  <p>1176x436x24 mm</p> <p>1</p>	<p>⑧</p>  <p>777x369x4 mm</p> <p>2</p>
<p>③</p>  <p>770x354x15 mm</p> <p>1</p>	<p>⑨</p>  <p>777x10x4 mm</p> <p>1</p>
<p>④</p>  <p>770x354x15 mm</p> <p>1</p>	<p>⑬</p>  <p>1200x300x24mm</p> <p>1</p>
<p>⑤</p>  <p>770x416x15 mm</p> <p>1</p>	<p>⑮</p>  <p>240 x 20 mm</p> <p>1</p>
<p>⑥</p>  <p>733x288x12 mm</p> <p>1</p>	<p>⑳</p>  <p>75 x 70 x 25 mm</p> <p>4</p>

Components - Parts

<p>23</p>  <p>769x80x50 mm</p> <p>1</p>	<p>24</p>  <p>769x80x50 mm</p> <p>1</p>
<p>Hardware kid x1</p>  <p>1</p>	

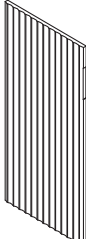
Components - Parts

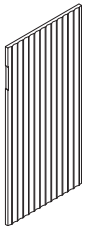
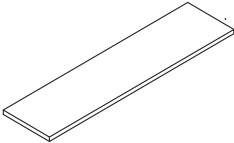
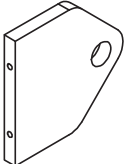
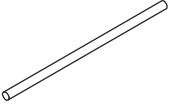
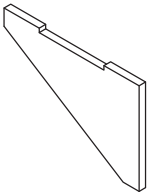
BOX B - N707P423692

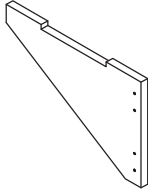

<p>⑩</p>  <p>764x354x15 mm</p> <p>1</p>	<p>⑱</p>  <p>448x90x12 mm</p> <p>2</p>
<p>⑪</p>  <p>764x354x15 mm</p> <p>1</p>	<p>⑲</p>  <p>448x90x12 mm</p> <p>2</p>
<p>⑫</p>  <p>764x354x15 mm</p> <p>1</p>	<p>⑳</p>  <p>274x90x12 mm</p> <p>4</p>
<p>⑭</p>  <p>118 x 118x 15 mm</p> <p>2</p>	<p>㉑</p>  <p>12x292 mm</p> <p>4</p>
<p>⑯</p>  <p>249 x 169 x 15 mm</p> <p>1</p>	<p>㉕</p>  <p>777x401x4 mm</p> <p>1</p>
<p>⑰</p>  <p>249 x 169 x 15 mm</p> <p>1</p>	

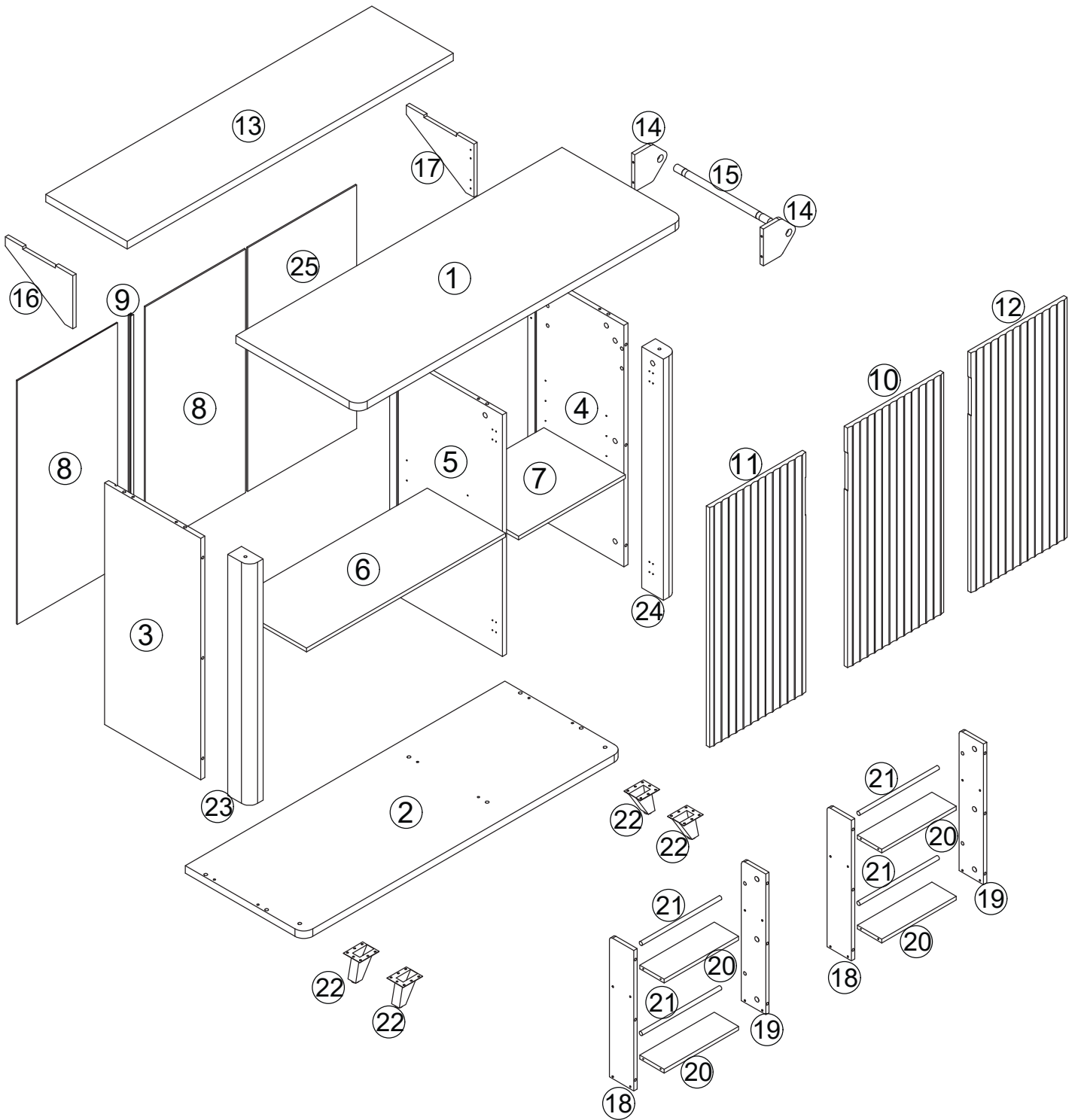
Assembly Instructions

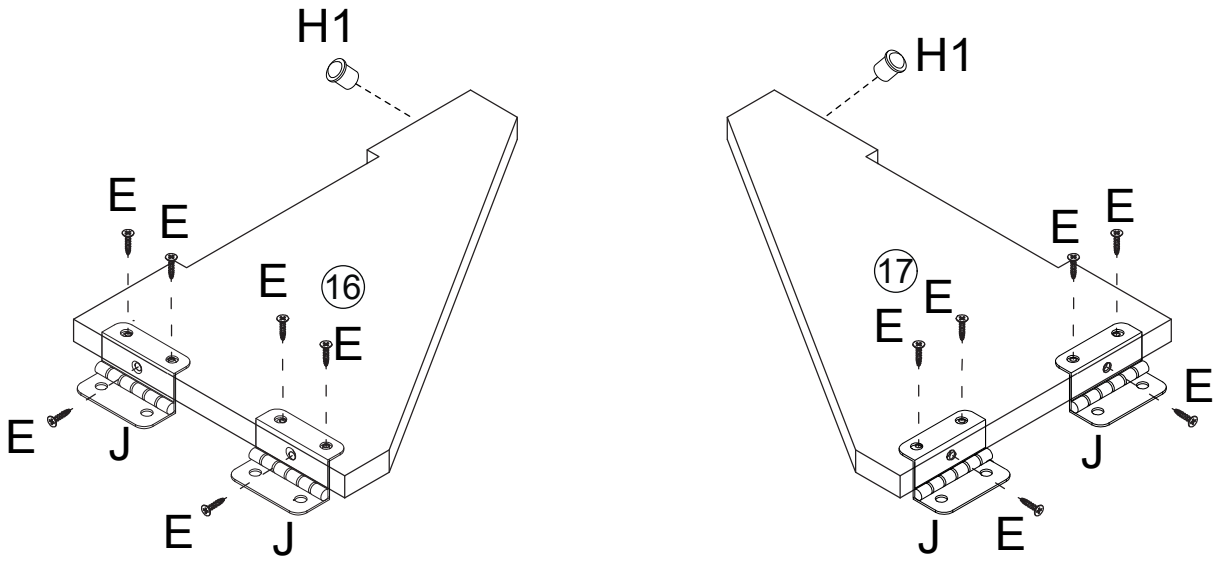

STEP 1

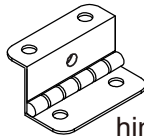

E  3x12mm Screw x 12	J  hinge x 4	H1  x 2
---	---	--

STEP 2

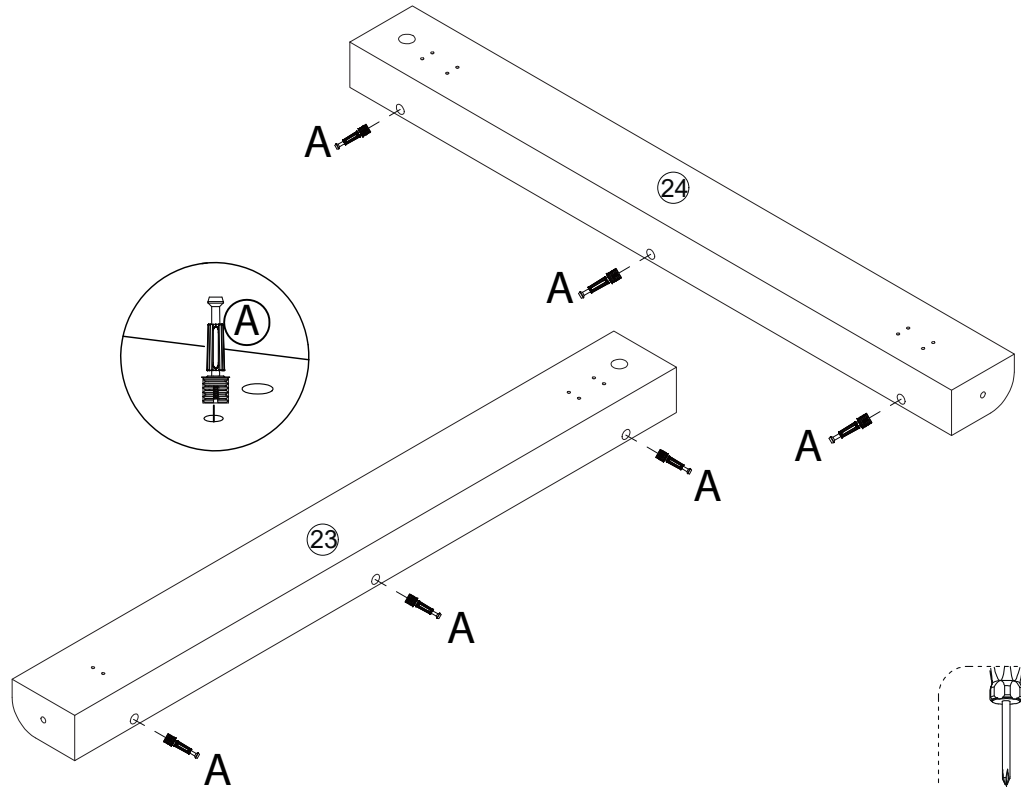

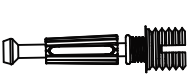

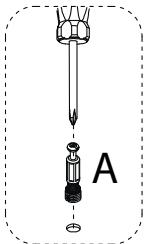
A  x6



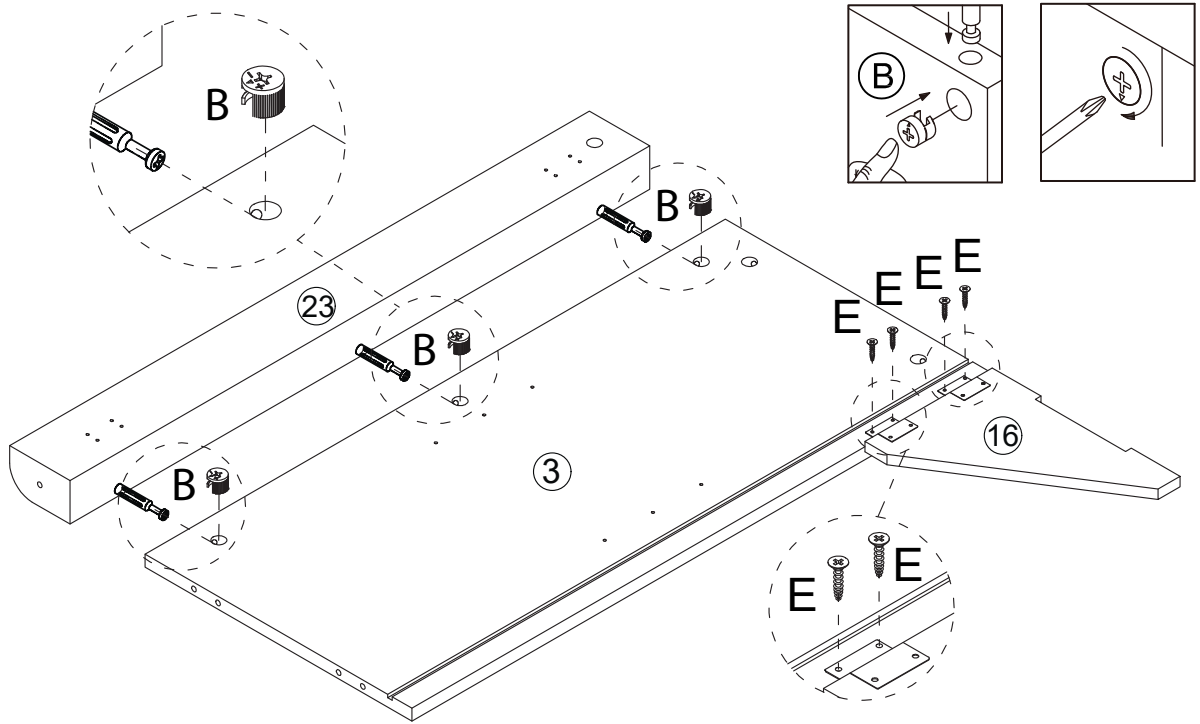

STEP 3

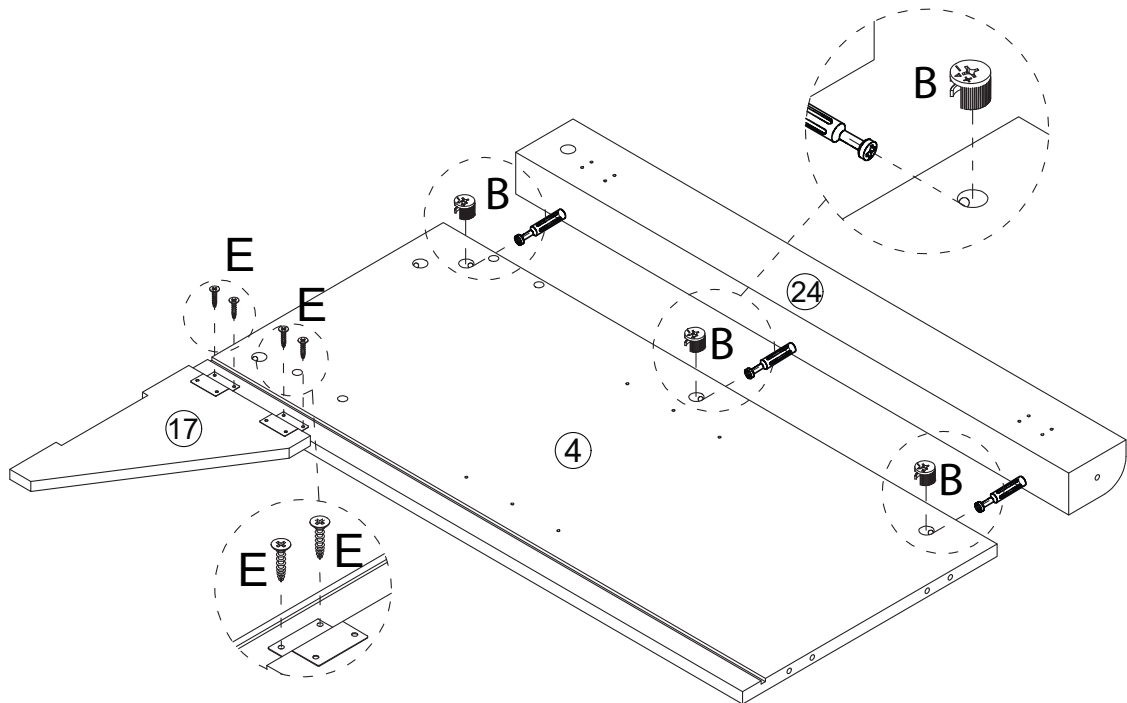

B  Cam lock x 3	E  3x12mm Screw x 4
--	--

STEP 4



B  Cam lock x 3	E  3x12mm Screw x 4
---	---

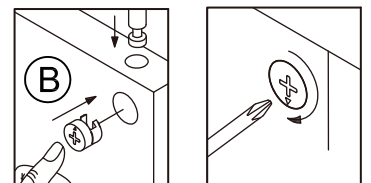



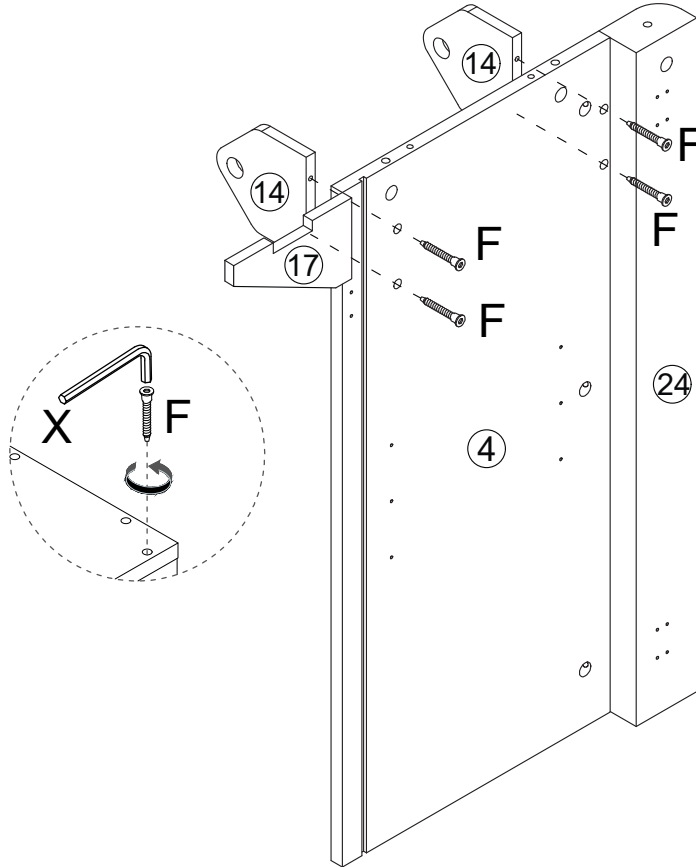

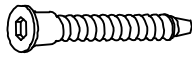
STEP 5

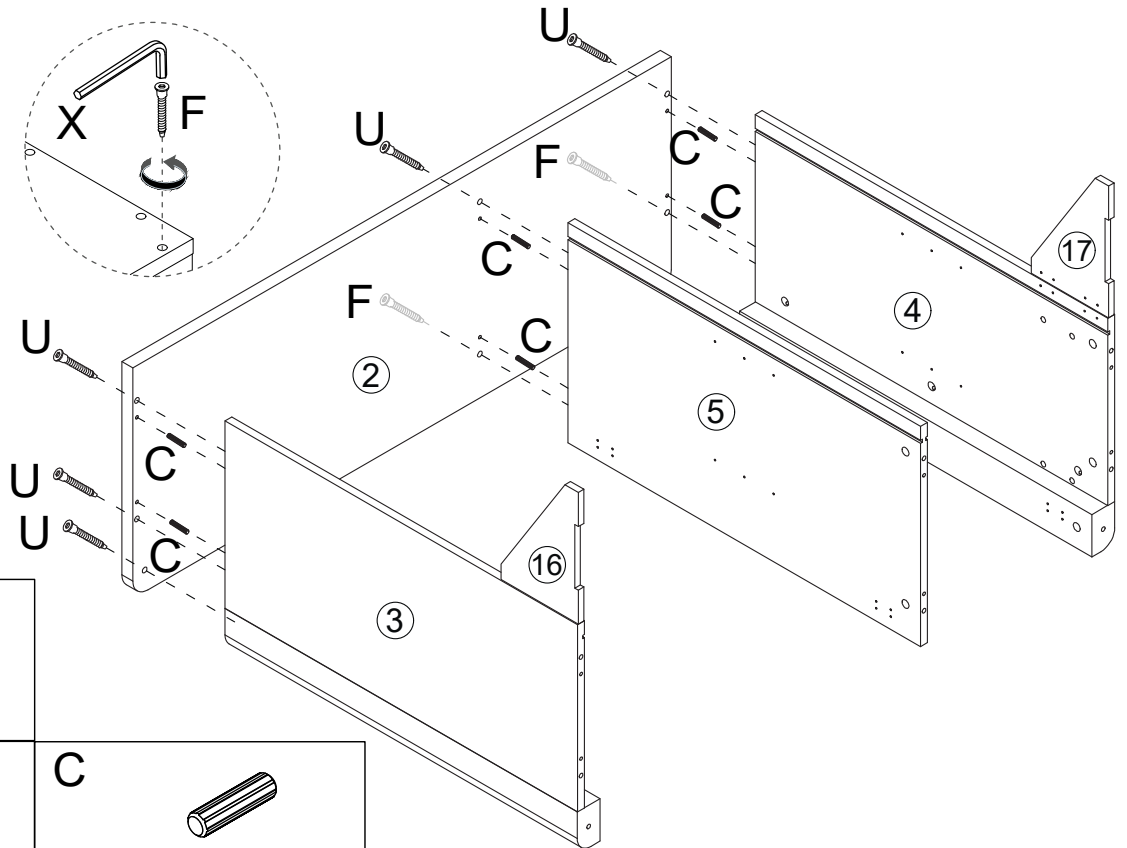

X	
	Allen Wrench x 1
F	
	7x40mm Screw x 4

STEP 6

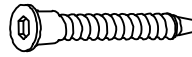

R		
	Allen Wrench x 1	
U		C
	7x50mm Screw x 8	
		6*40mm Dowel x 6

STEP 7

You can install caster wheels, or install fixed legs.

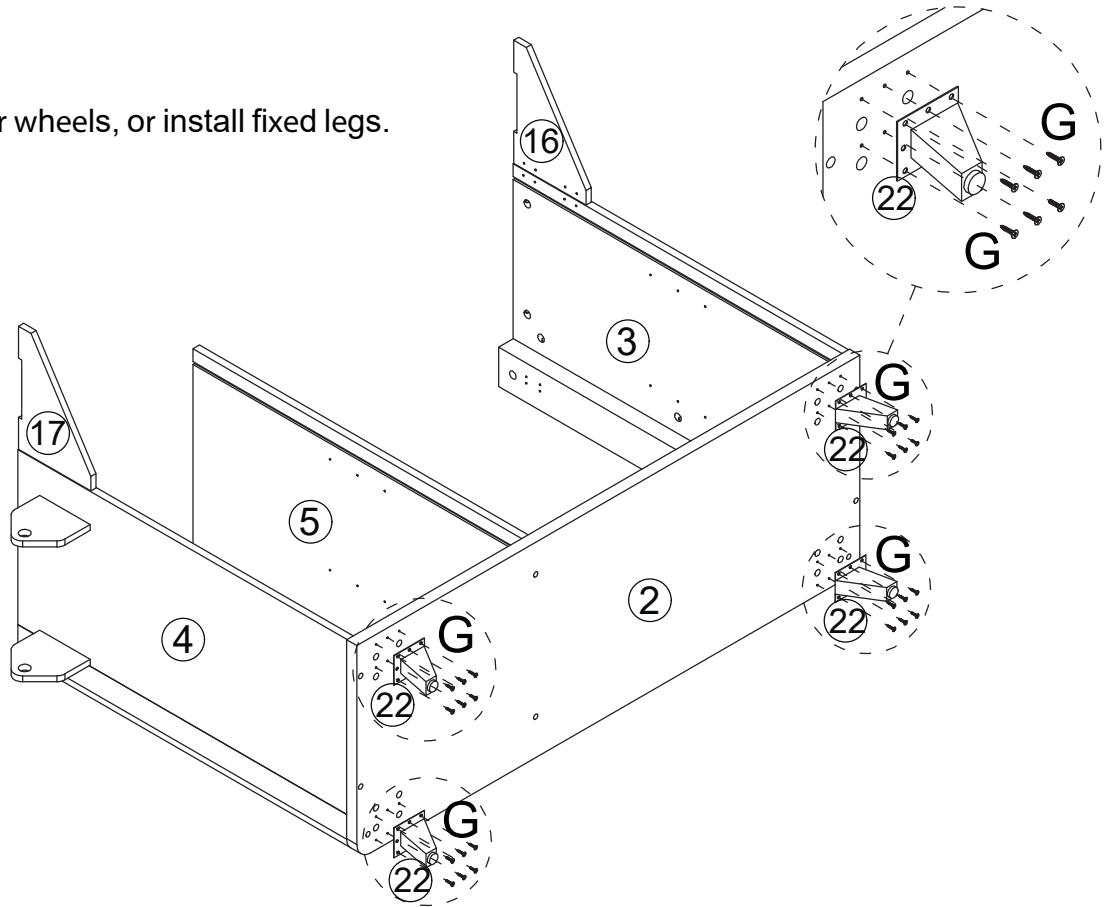

G



3x14mm Screw x 24

STEP 8

You can install caster wheels, or install fixed legs.

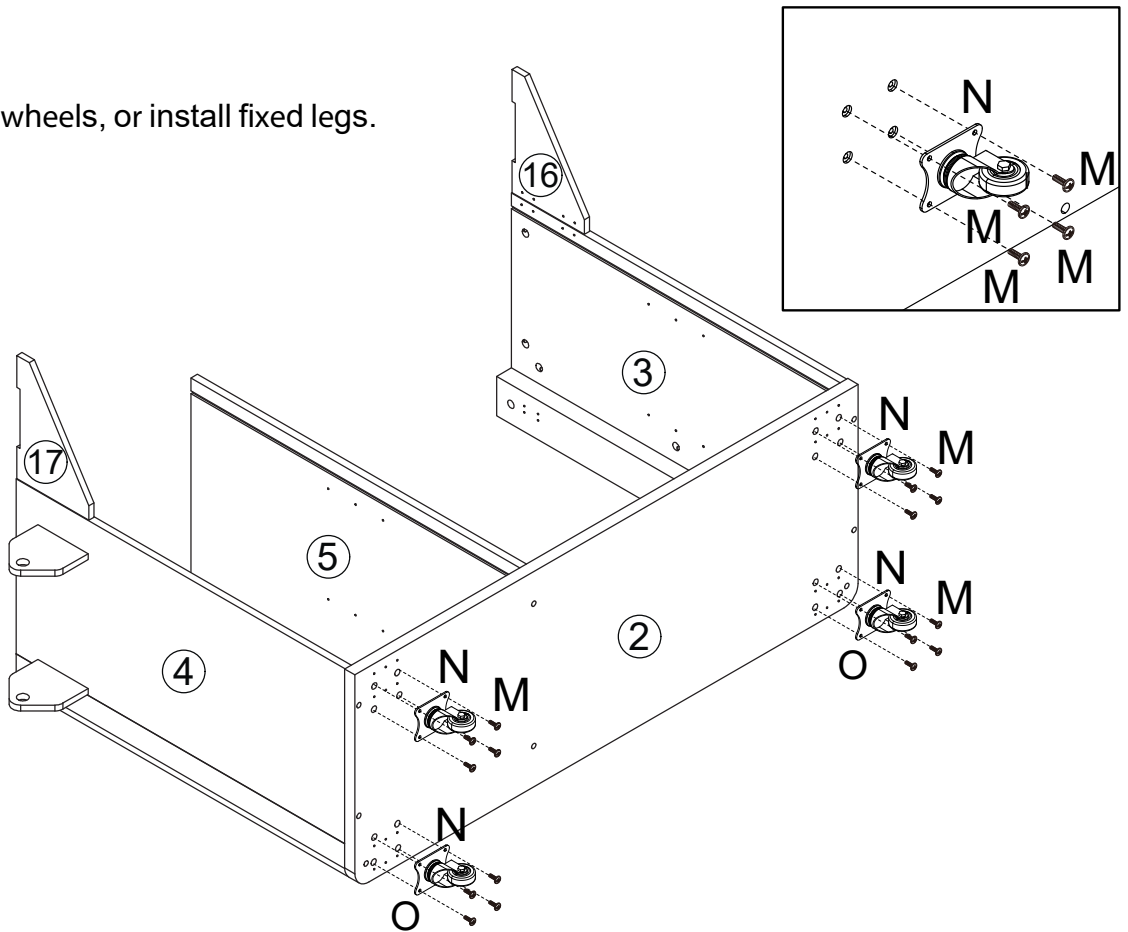

M



6*25mm Screw x 16

N

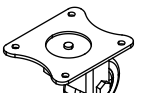

Caster x 2

O

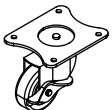

Locking caster x 2

STEP 9

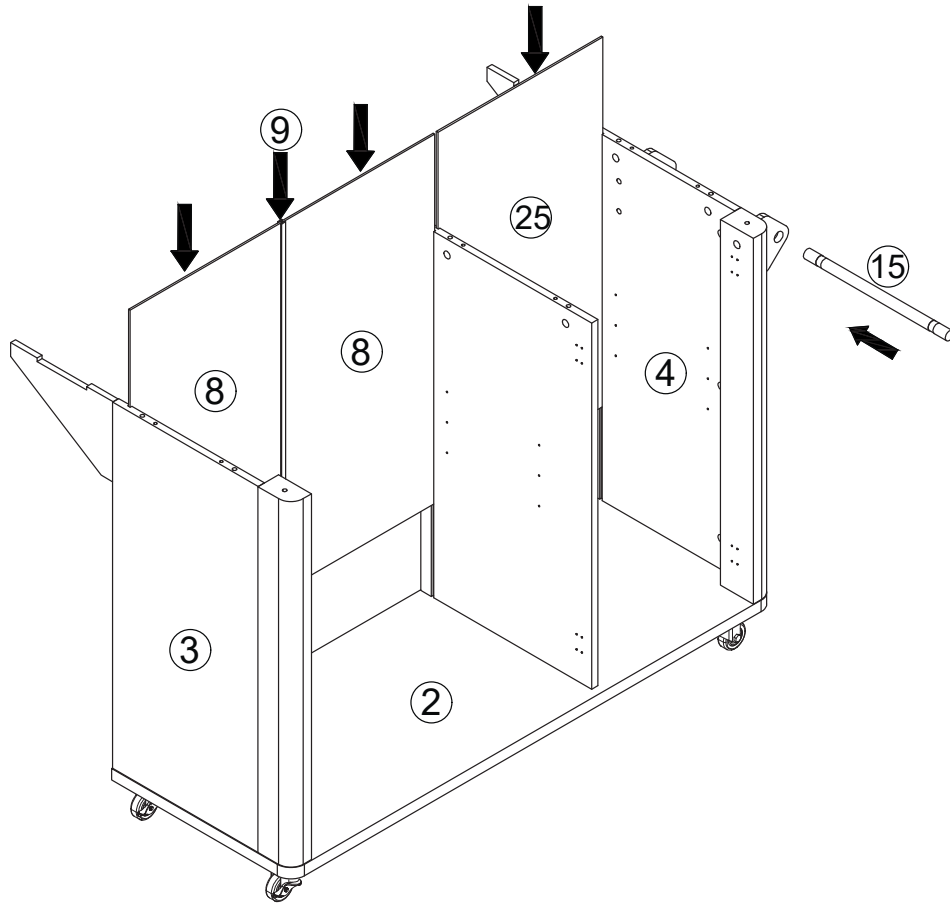

STEP 10

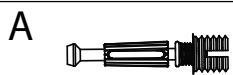
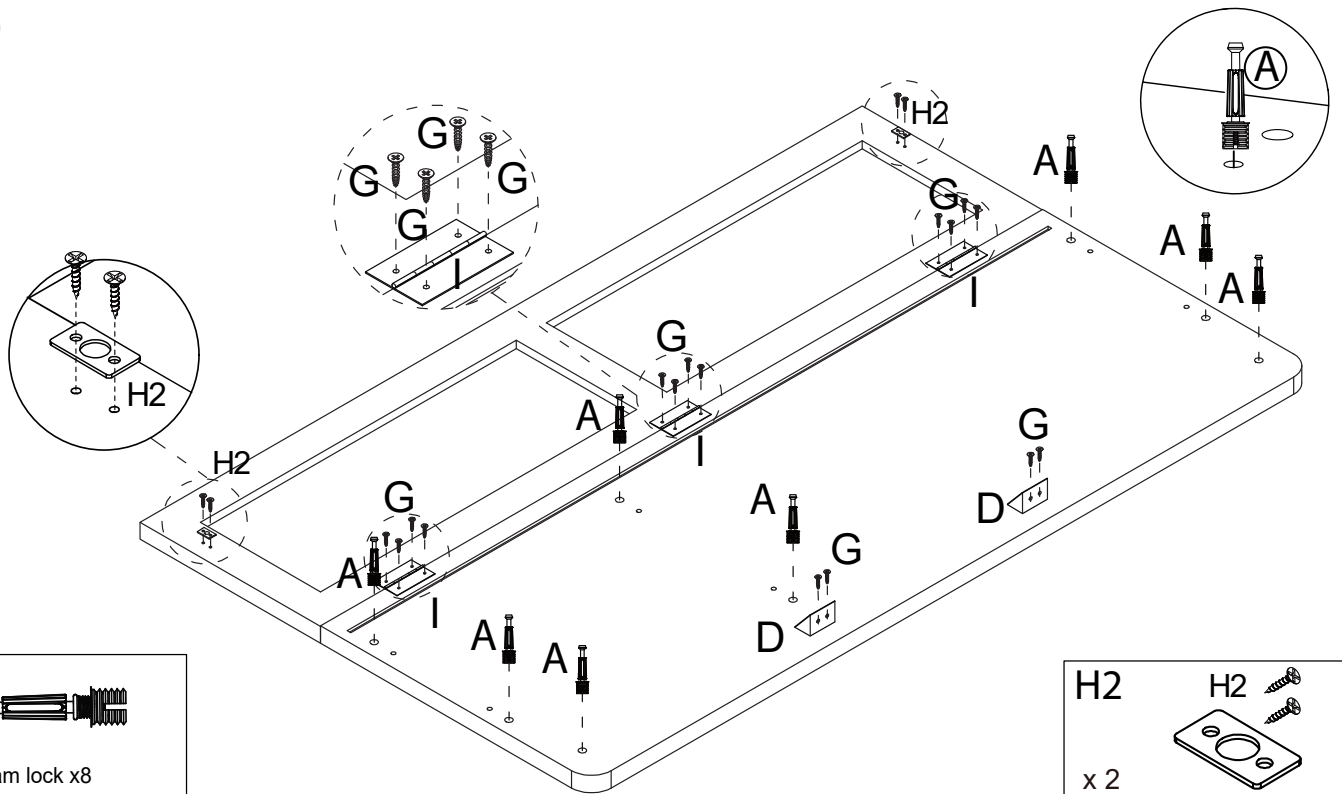

Cam lock x8

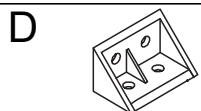

Angle iron x 2



3x14mm Screw x 16

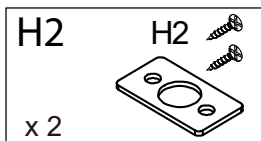

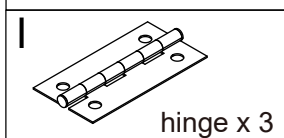

H2 x 2

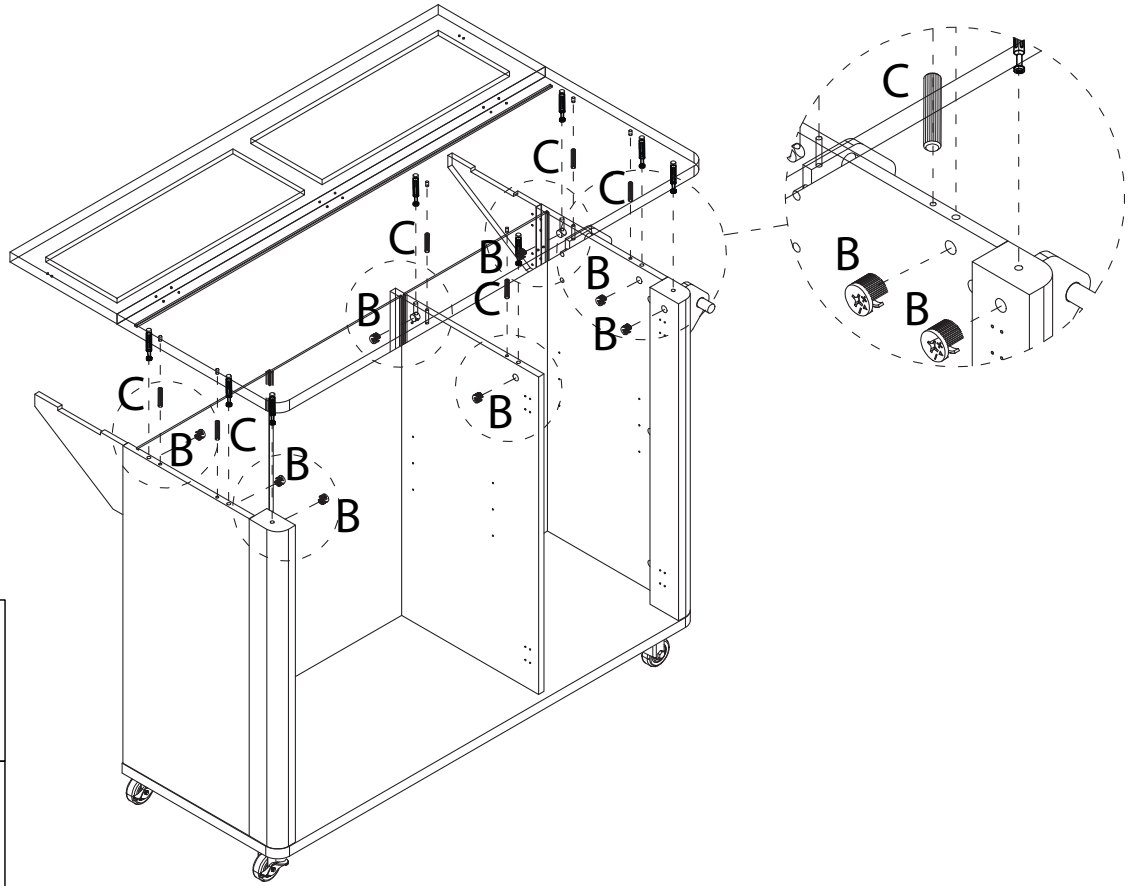

hinge x 3

STEP 11

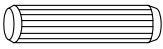

B	
Cam lock x8	
C	
6x40mm Dowel x 6	



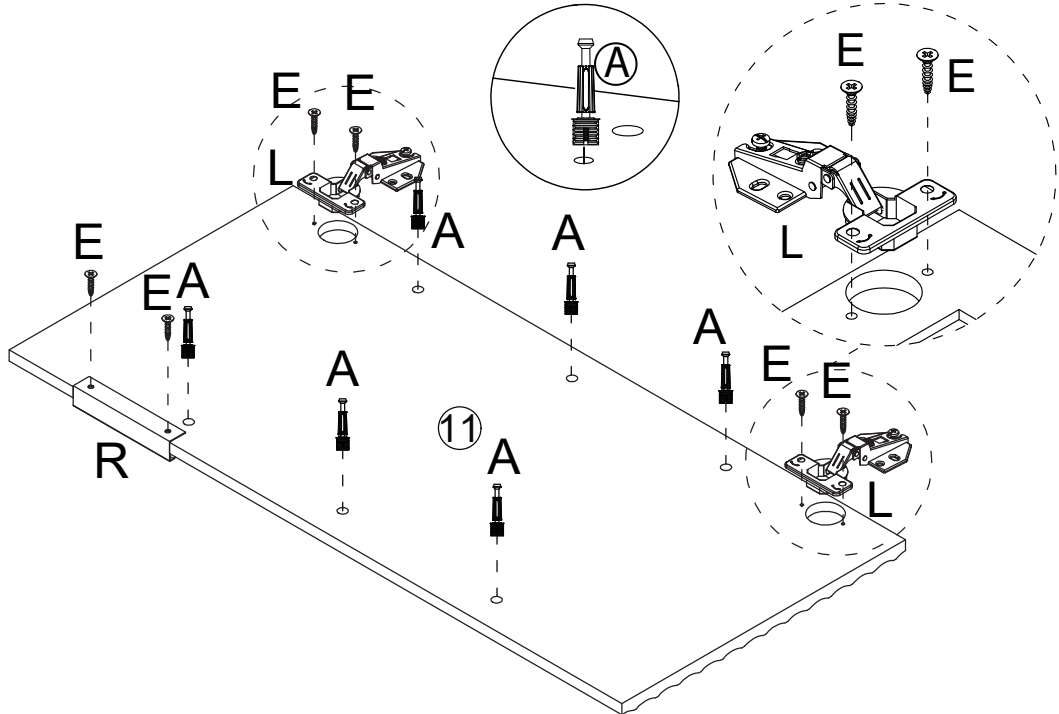

STEP 12

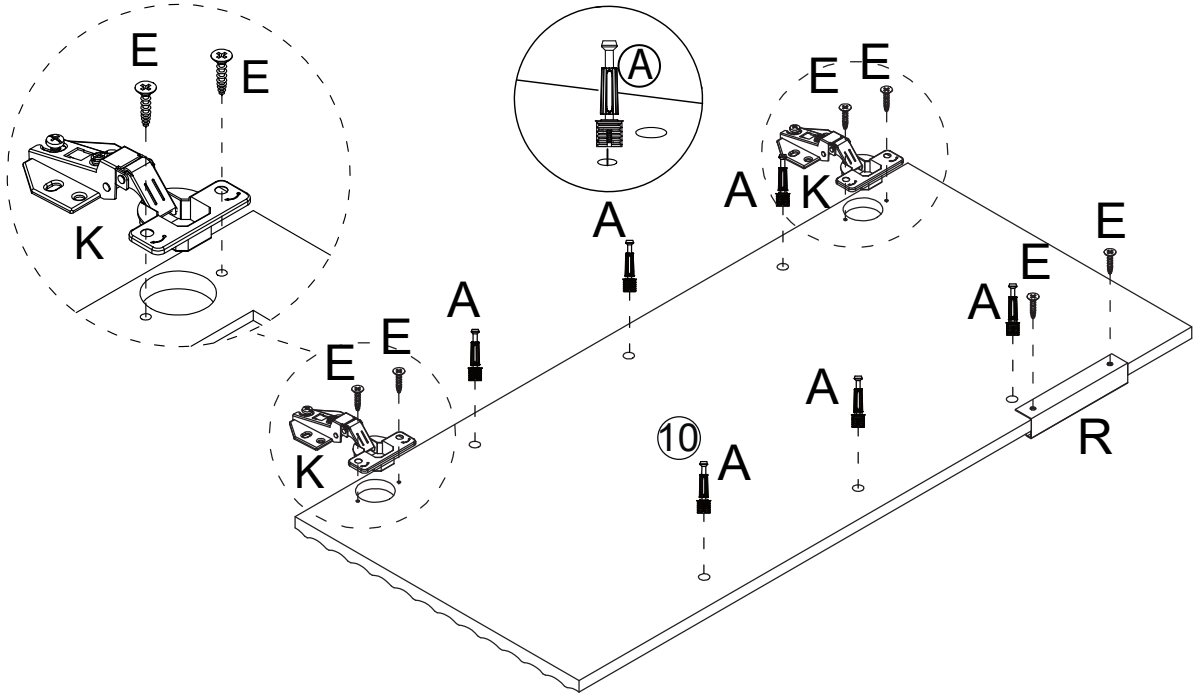

A  <p>Cam lock x6</p>	E  <p>Screw x 6</p>	R  <p>Allen Wrench x 1</p>	L  <p>ZMx2</p>
---	---	---	--

STEP 13

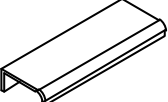

<p>A</p>  <p>Cam lock x6</p>	<p>E</p>  <p>Screw x 6</p>	<p>R</p>  <p>Allen Wrench x 1</p>	<p>K</p>  <p>DMx2</p>
---	---	--	--

STEP 14

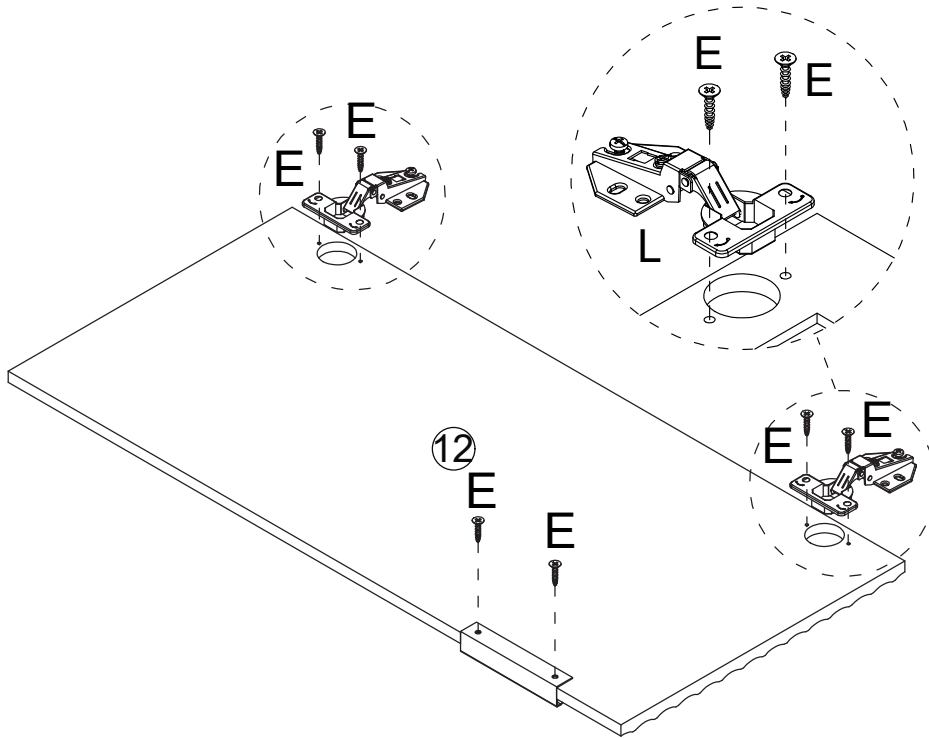

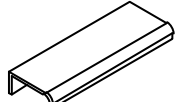
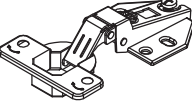
<p>E</p>  <p>Screw x 6</p>	<p>R</p>  <p>Allen Wrench x 1</p>	<p>L</p>  <p>ZMx2</p>
--	---	---

STEP 15

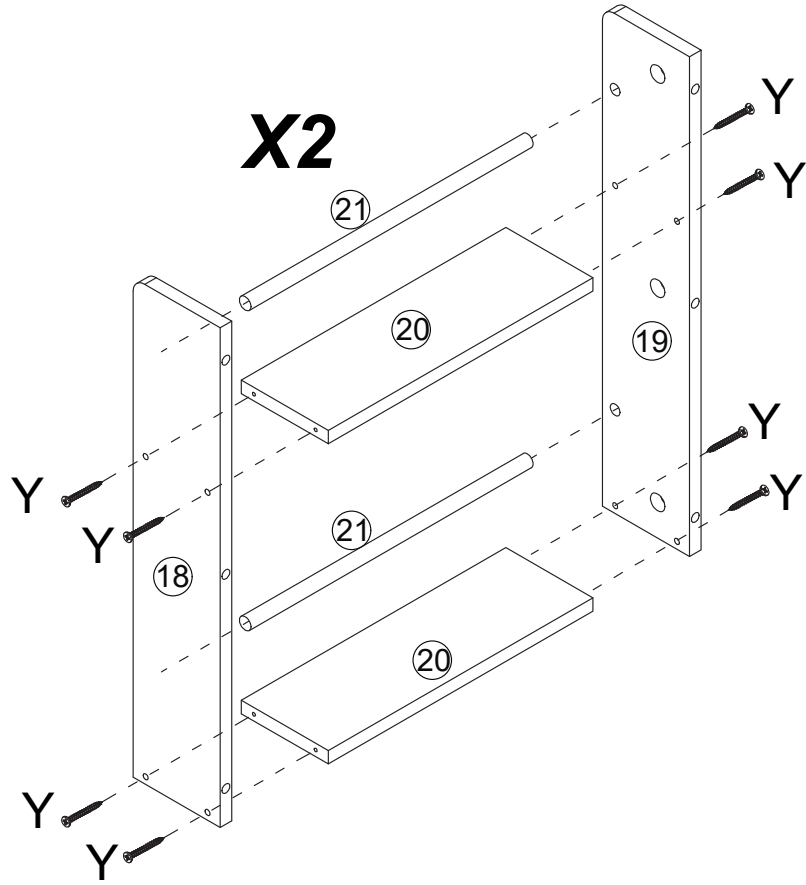

STEP 16

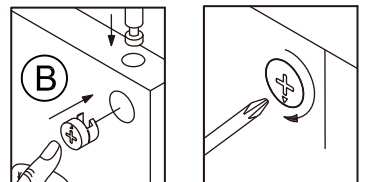
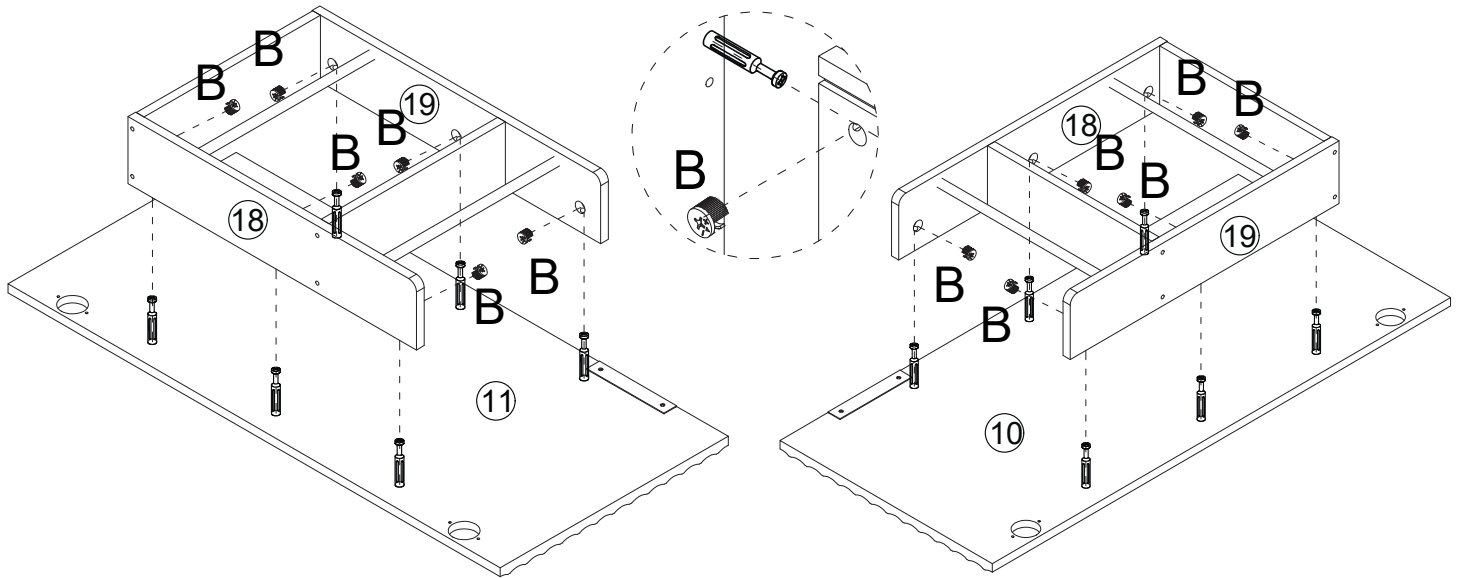

STEP 17

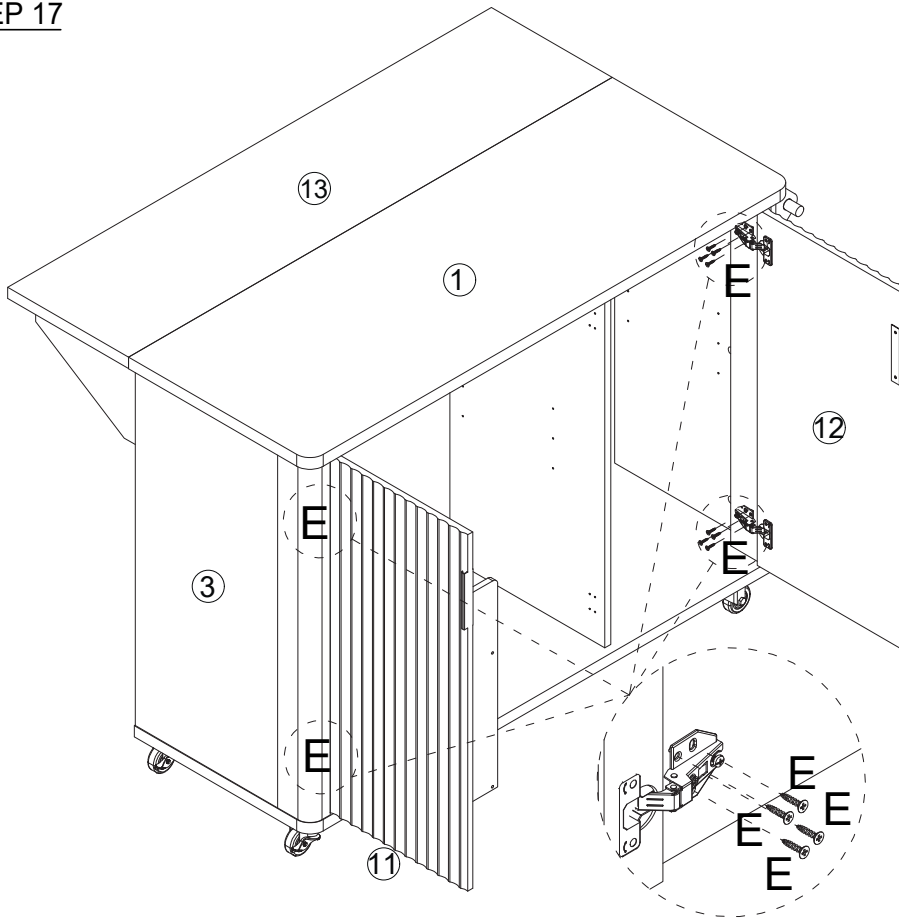

ADJUSTING POSSIBILITIES

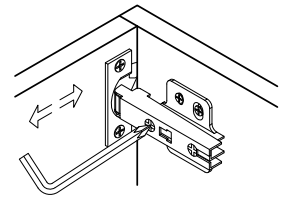

• LATERAL ADJUSTMENT BY SCREW ADJUSTMENT

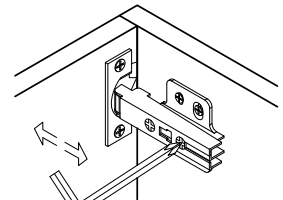

• FRONT-TO-BACK BY SLACKENING THE HINGE-ARM MOUNTING SCREW

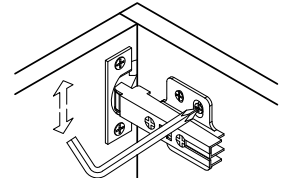

• VERTICAL ADJUSTMENT VIA MOUNTING PLATE (VIA SLOTS OR, IF IN TWO PIECES, BY SCREWS)

STEP 18

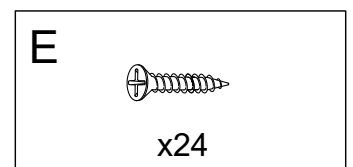
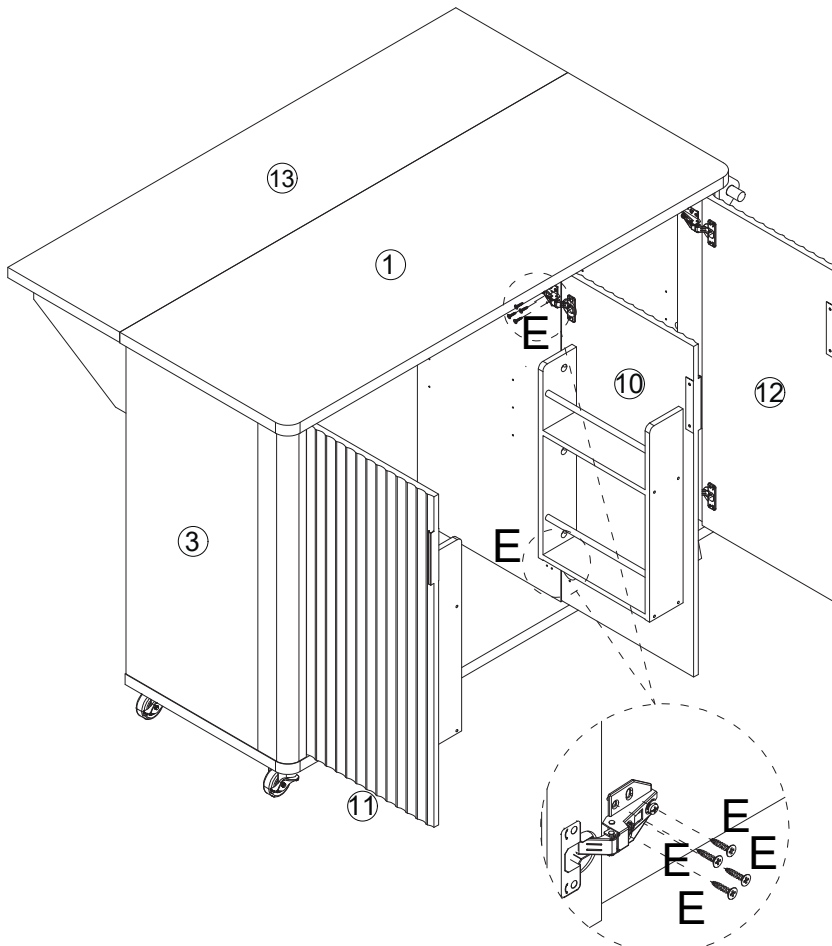

STEP 19

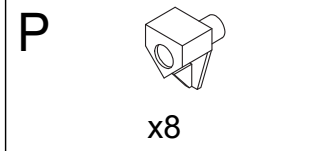
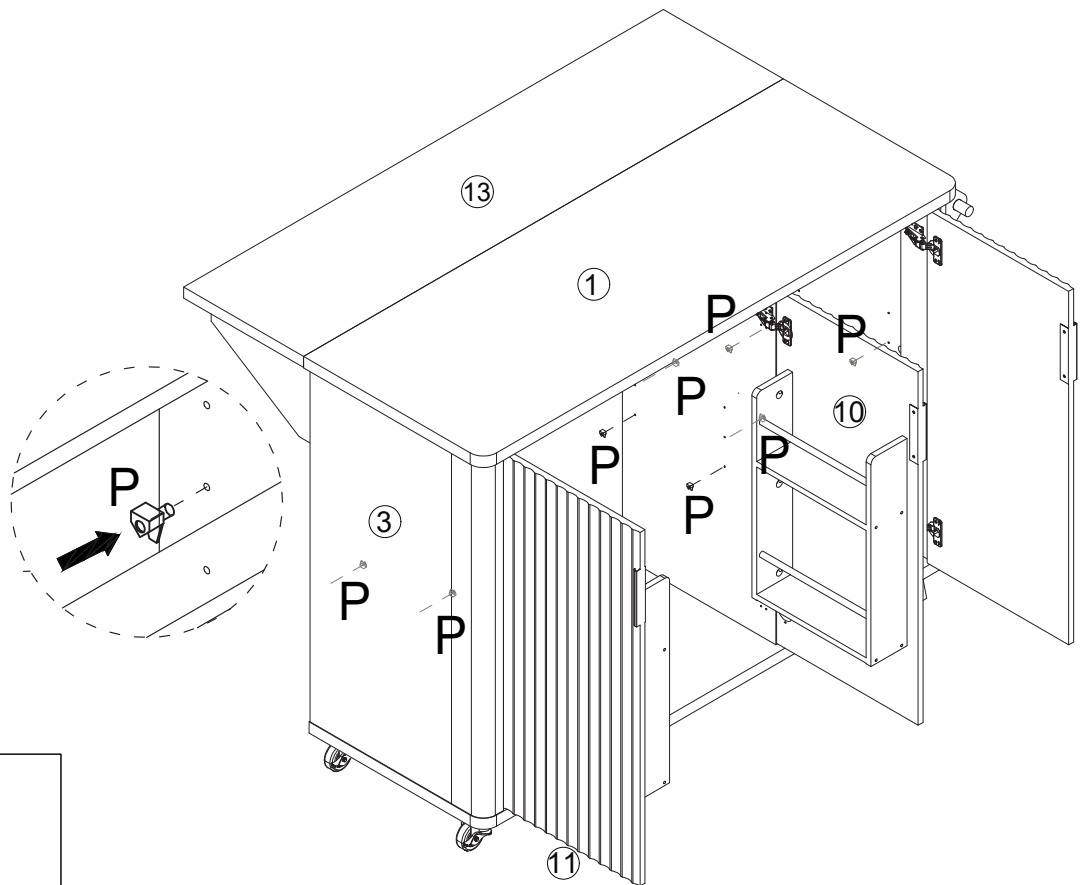

STEP 20

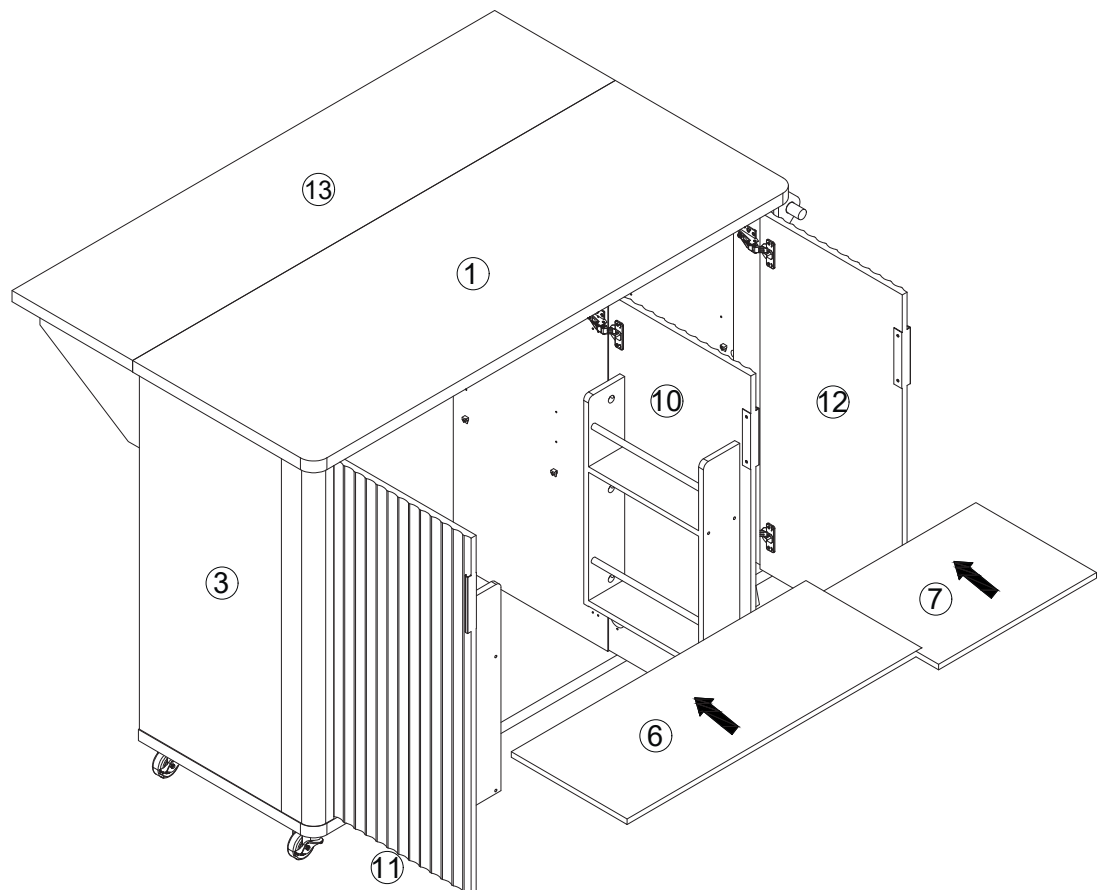

STEP 21

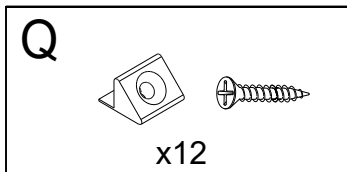
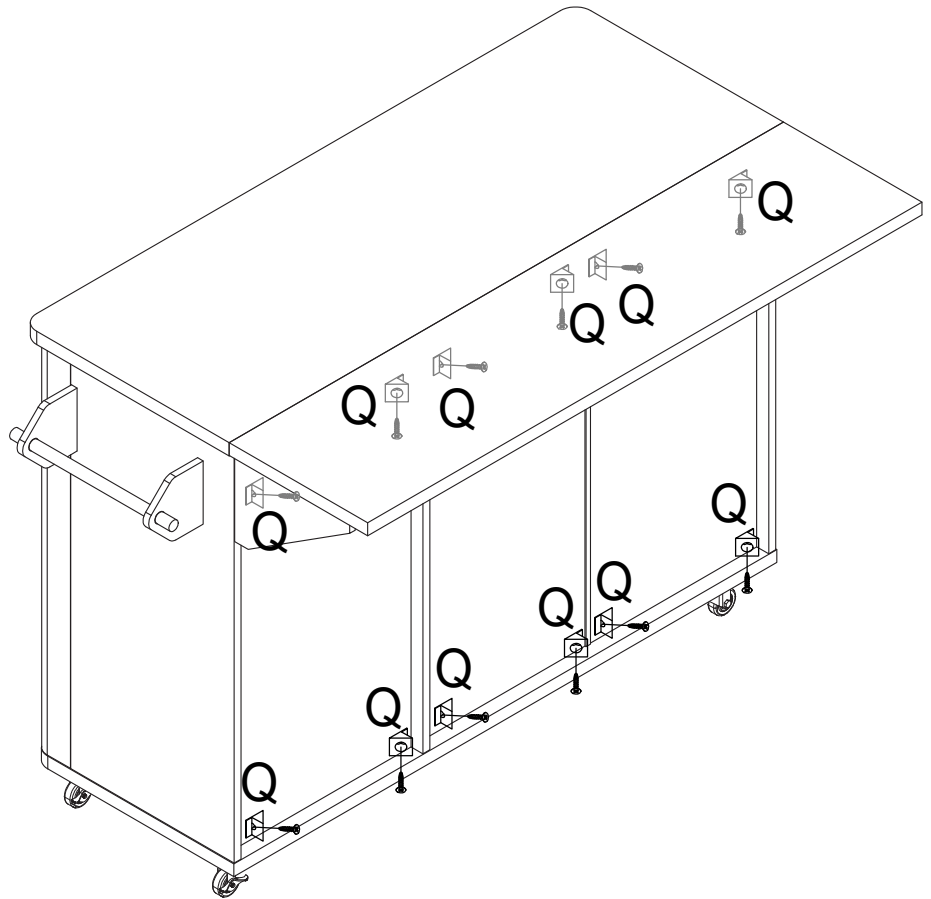

STEP 22

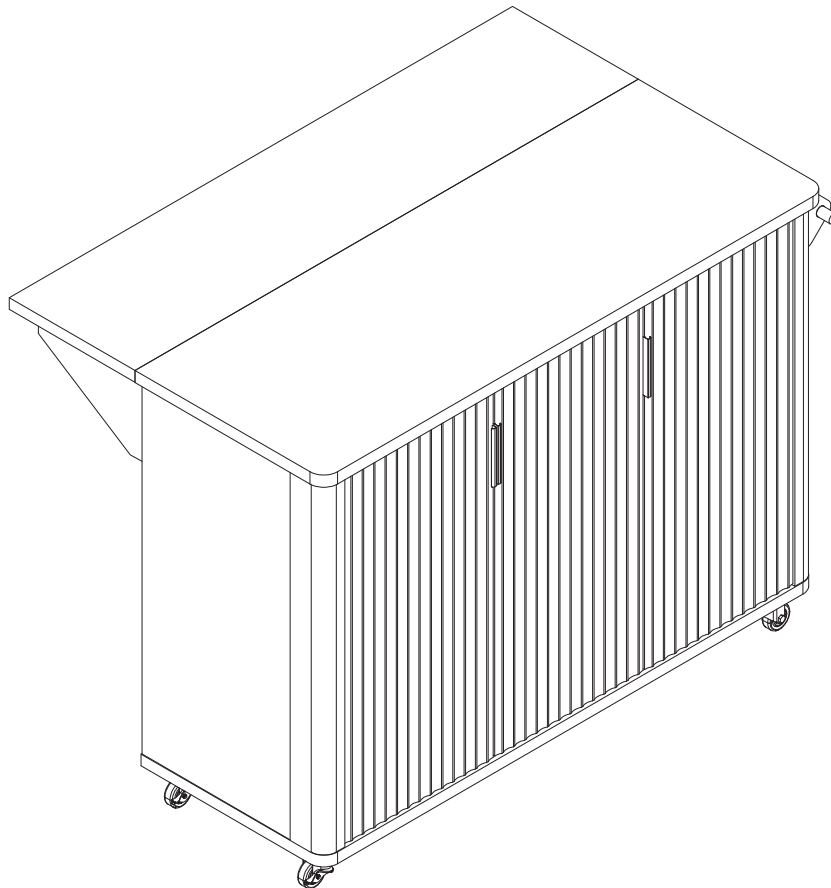

FINISH