

## Coffee Table

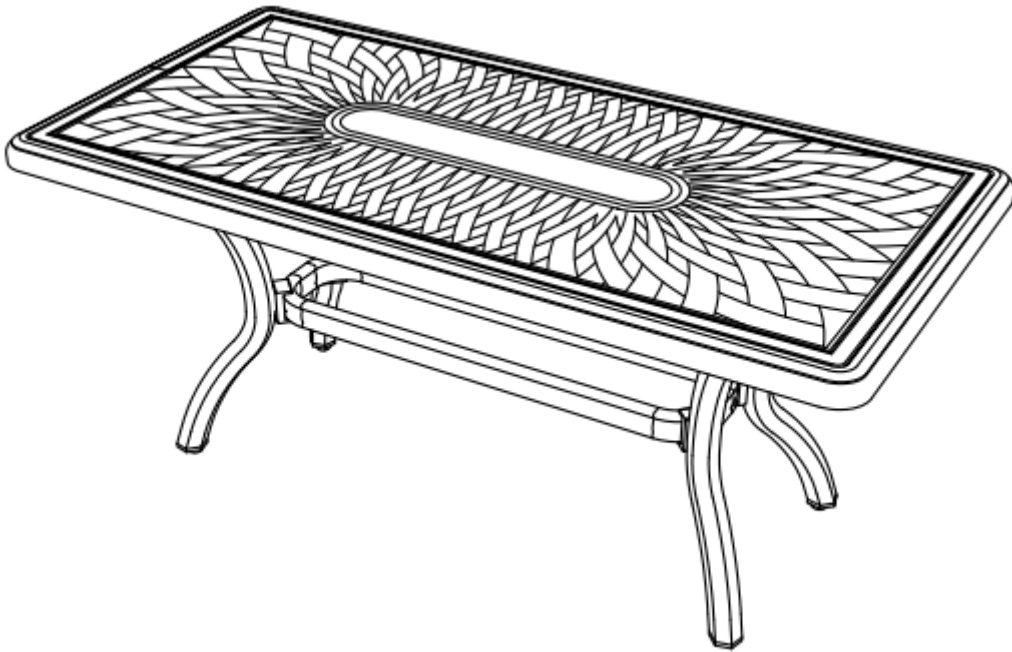











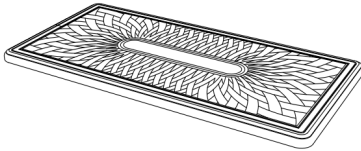
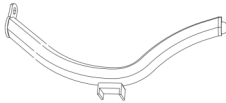

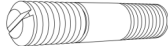
## WARNING!

- Failure to tighten bolts may cause injury.

Please read instructions carefully and thoroughly before assembling. Check parts against the parts list to make sure you have all the parts needed for proper assembly. Familiarize yourself with the inventory of parts and the accompanying illustrations to ensure safe and proper assembly.

**Place the table on a non-abrasive flat surface to prevent scratching.**

## PARTS LIST

PART	DESCRIPTION	PICTURE	QTY
A	TABLE TOP		1
B	TABLE LEG		4
C	LEG CONNECTOR BRACE		1
D	BOLT(5/16*30) (Pre-attached)		4
E	LARGE FLAT WASHER (Pre-attached)		4
F	LARGE LOCK WASHER (Pre-attached)		4
G	NUT (Pre-attached)		4
H	NUT COVER		4
J	BOLT(1/4*35) (Pre-attached)		4
K	SMALL FLAT WASHER (Pre-attached)		4
L	SMALL LOCK WASHER (Pre-attached)		4
M	BOLT COVER		4
N	WRENCH		1
O	HEX SCREW DRIVER		1

**1** Remove all protective material carefully. Avoid cutting the surface of the furniture while removing the packaging material. From the inside of the leg connector or brace (C), loosely attach the leg connector brace (C) to the legs (B) with the bolts (J) through the small flat washers (K), small lock washers (L) using hex screw driver (O). As shown in figure 1.  
DO NOT TIGHTEN BOLTS AT THIS POINTS.

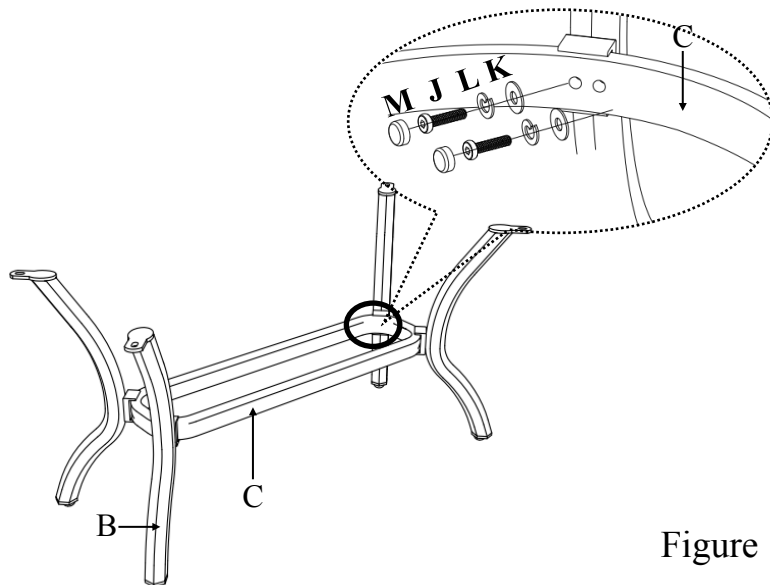

Figure 1

**2** Carefully turn the table top (A) upside down on a soft surface. Align the holes in the legs (B) with the holes in the table top (A). Loosely secure table legs (B) to table top (A) by the bolts (D) through large flat washers (E), large lock washers (F) and nuts (G) using wrench (N). As shown in figure 2.  
DO NOT TIGHTEN BOLTS AT THIS POINTS.

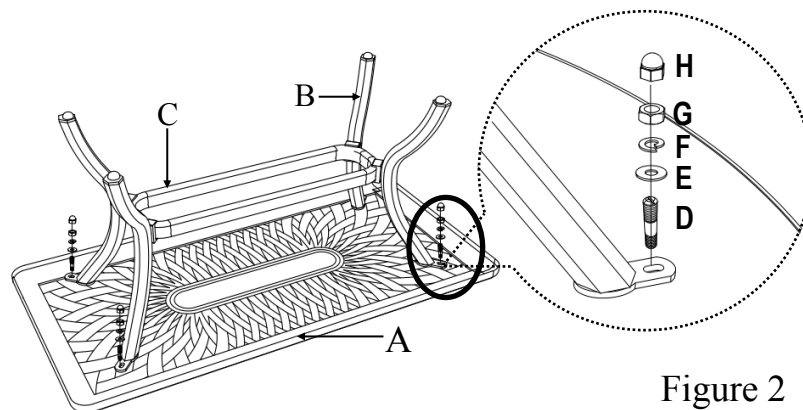

Figure 2

**3** Check the alignment of all table legs (B), and adjust if necessary. Once the alignment is correct and all bolts (D&J) and nuts (G) are in place, tighten all nuts (G) using wrench (N). Cover all bolts (D) and nuts (G) with bolt cover (M) and nut covers (H). With the help of another person, carefully turn the table to the upright position. The table is ready for your enjoyment.

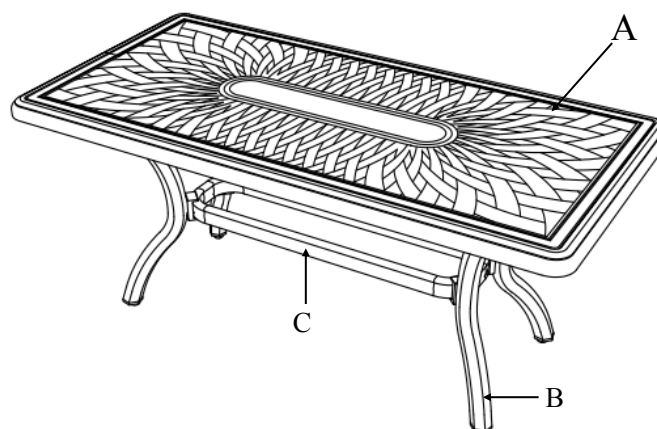

Figure 3