

1

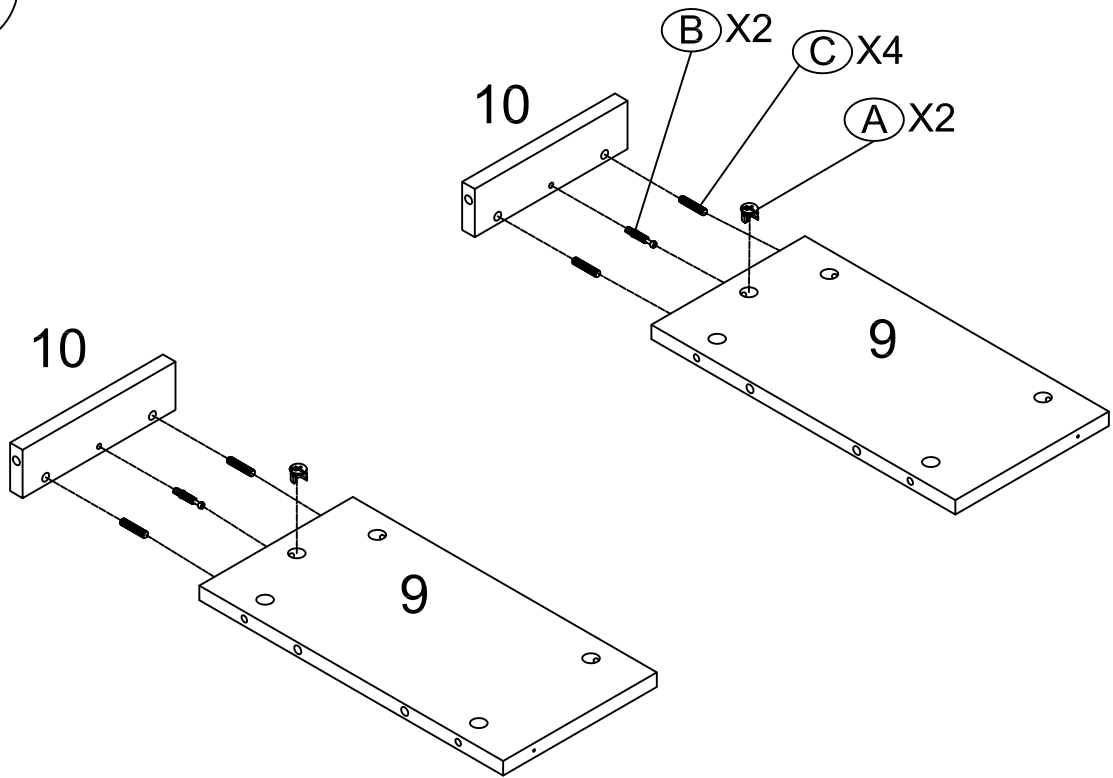

2

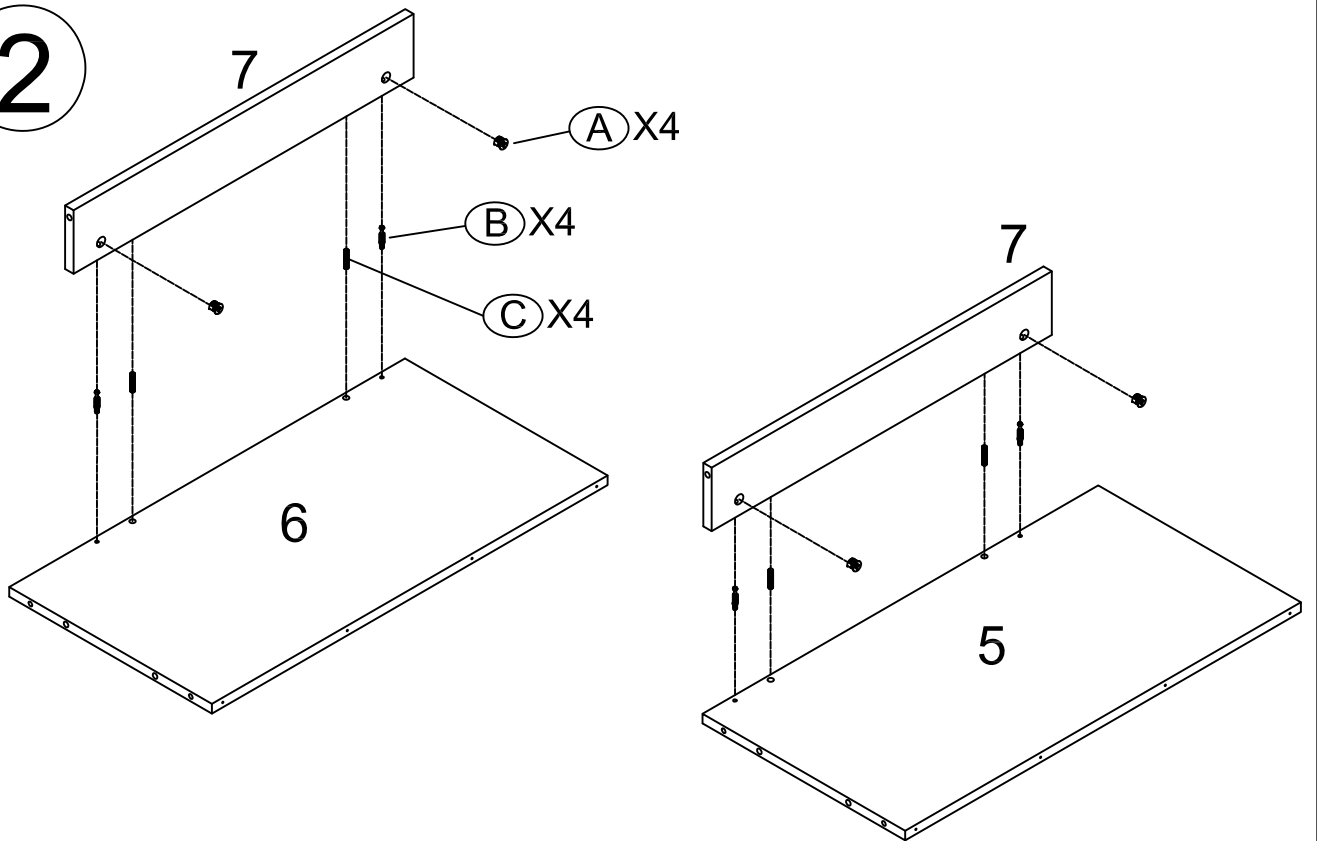

3

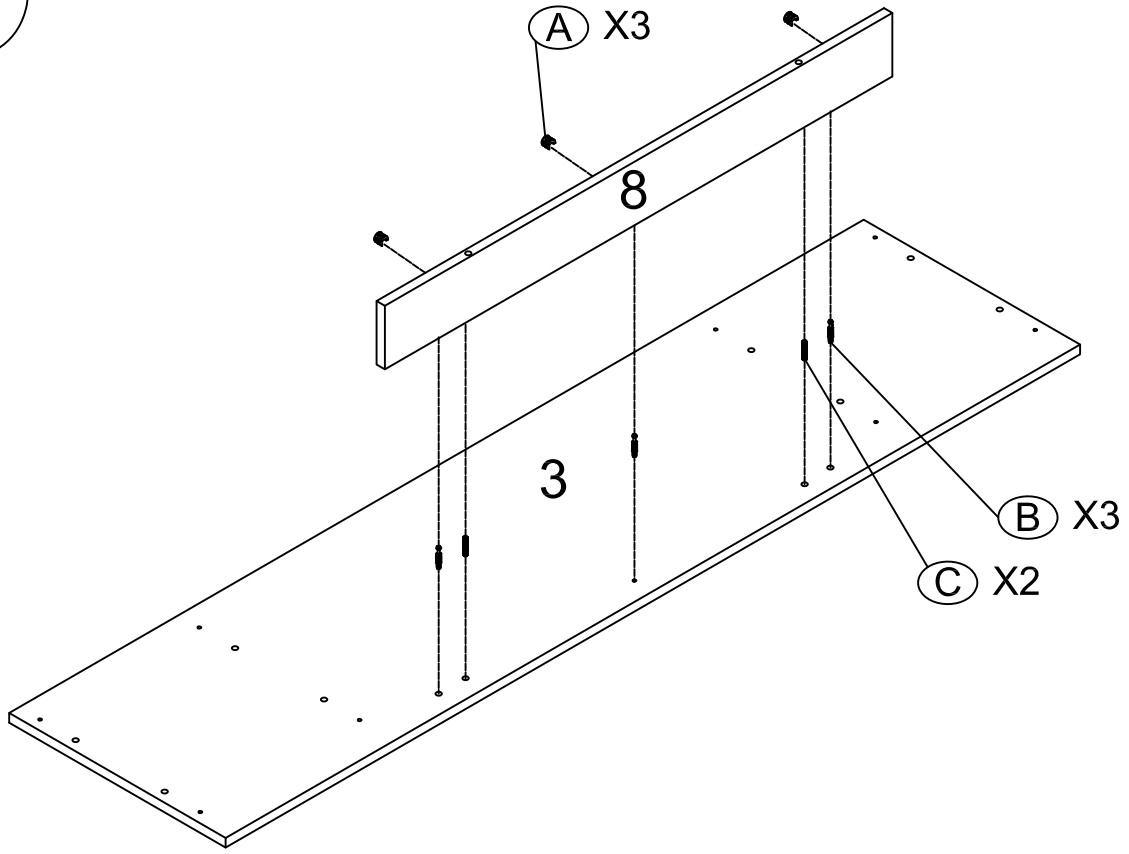

4

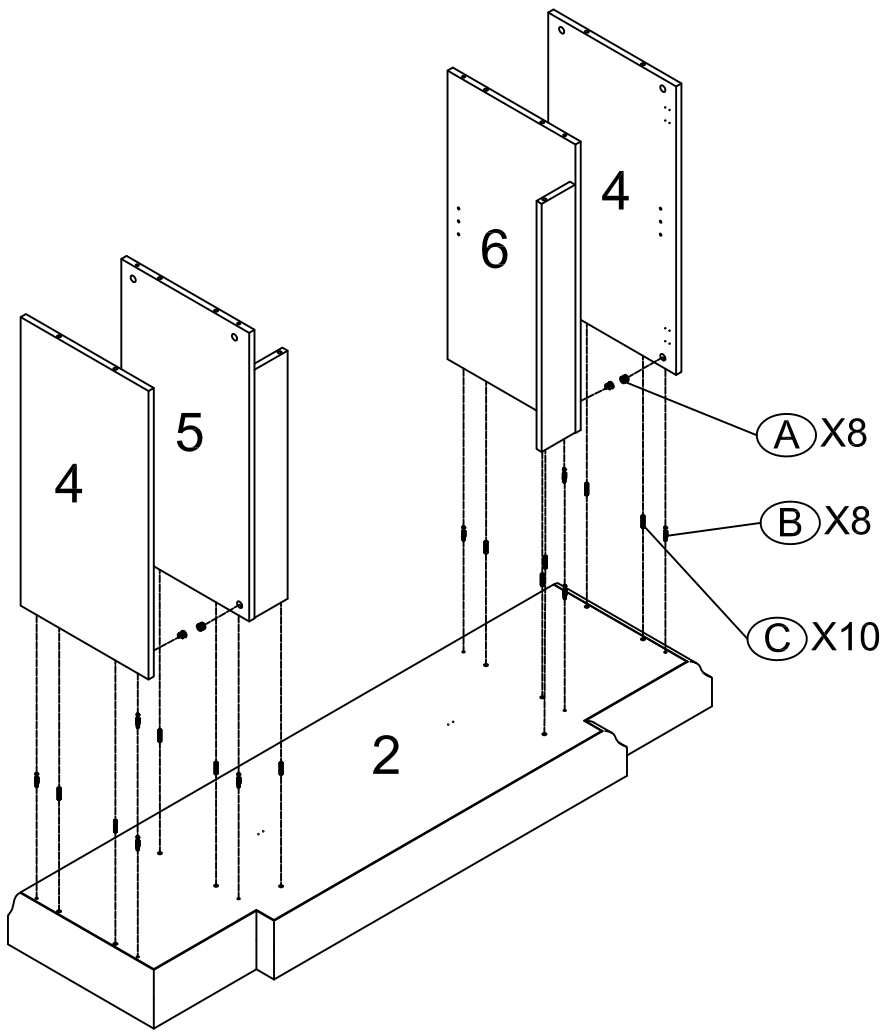

5

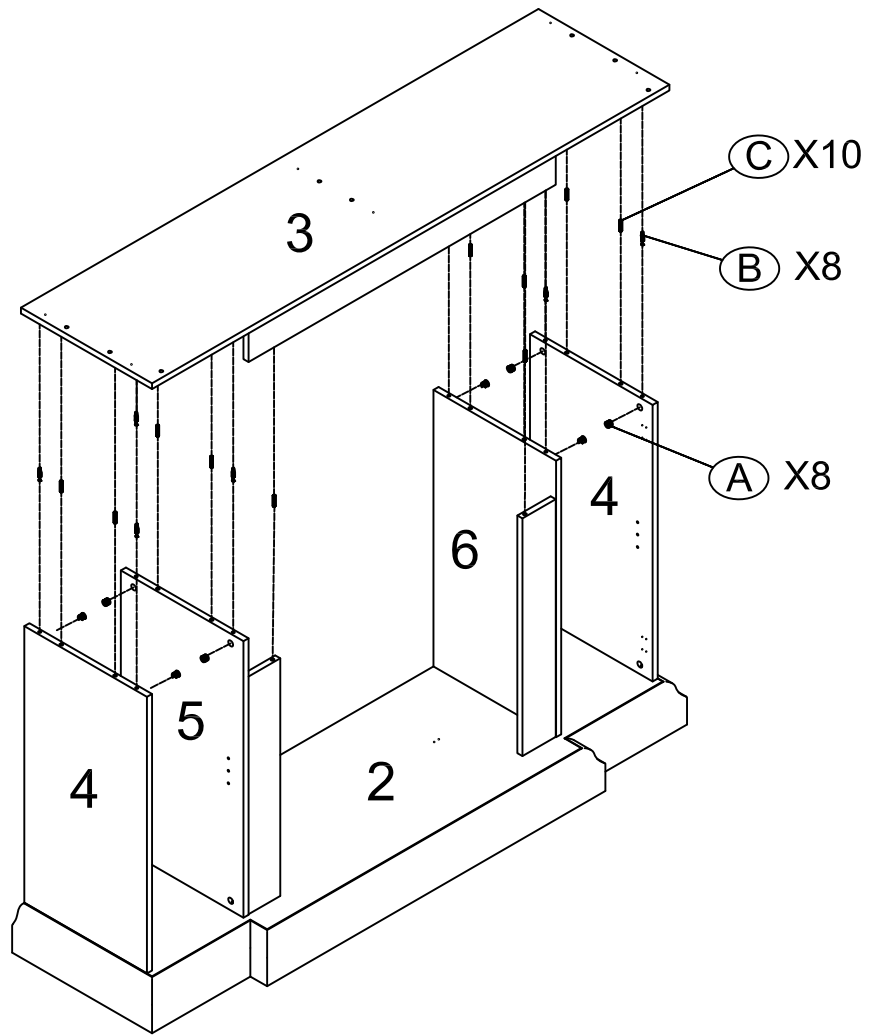

6

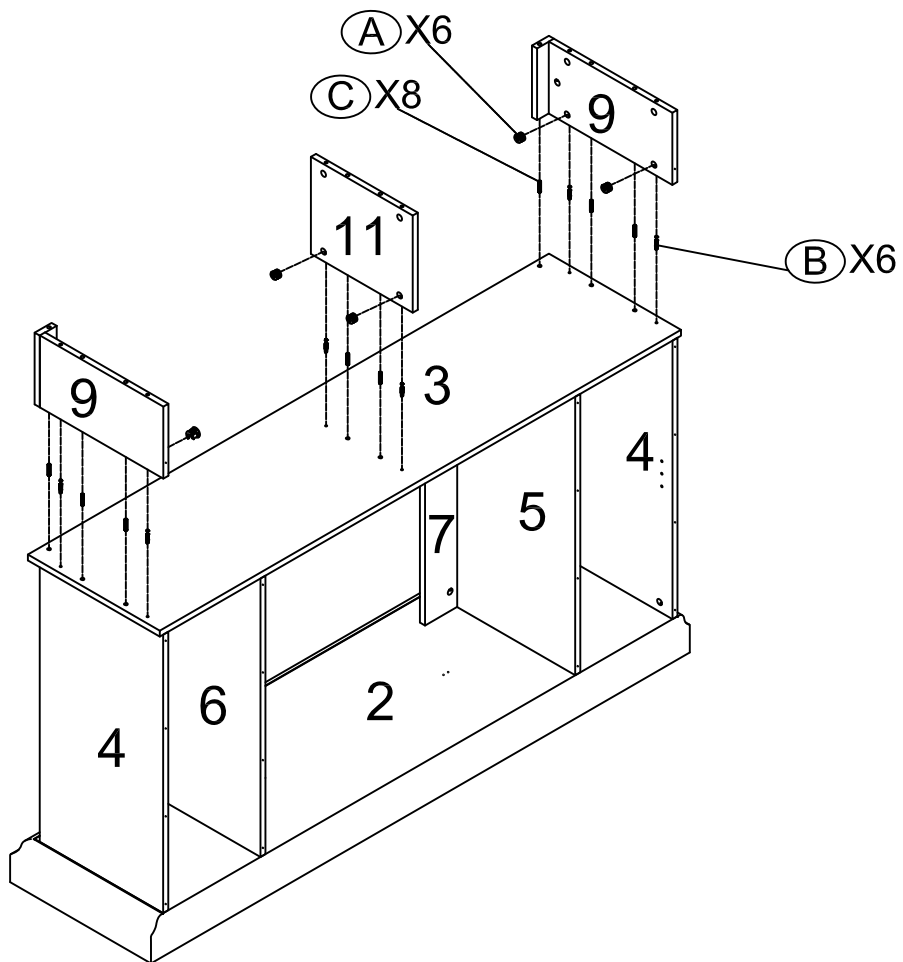

7

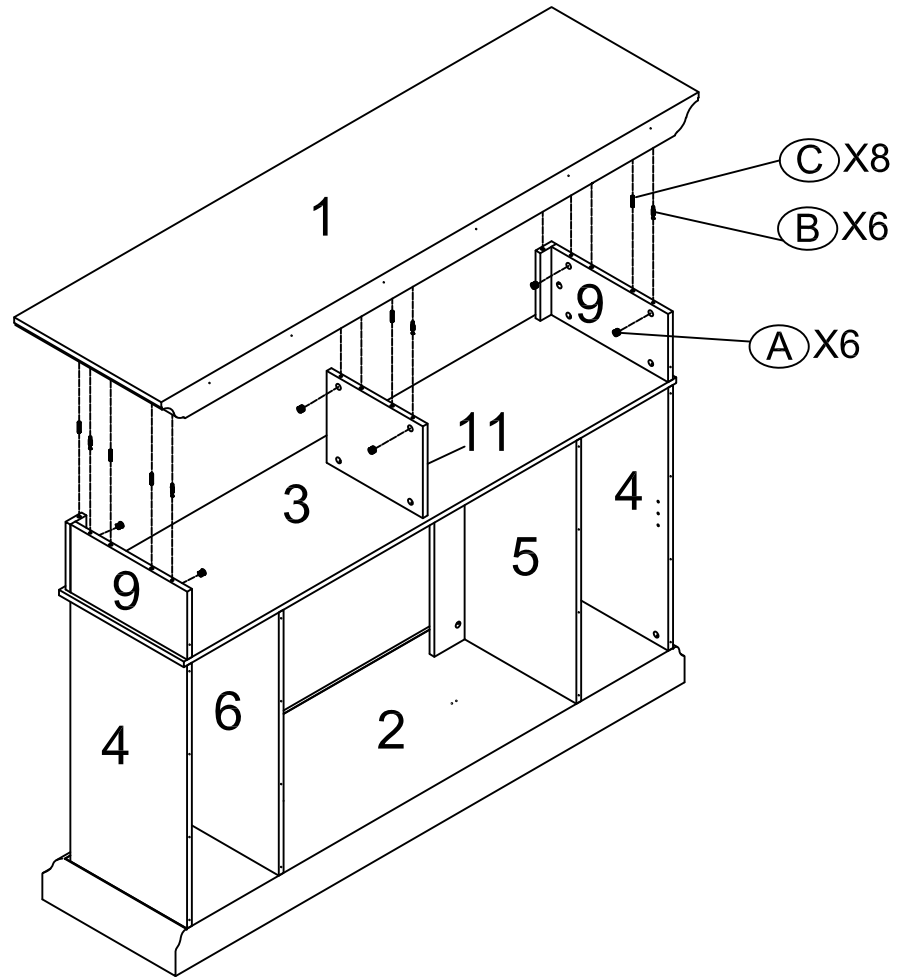

8

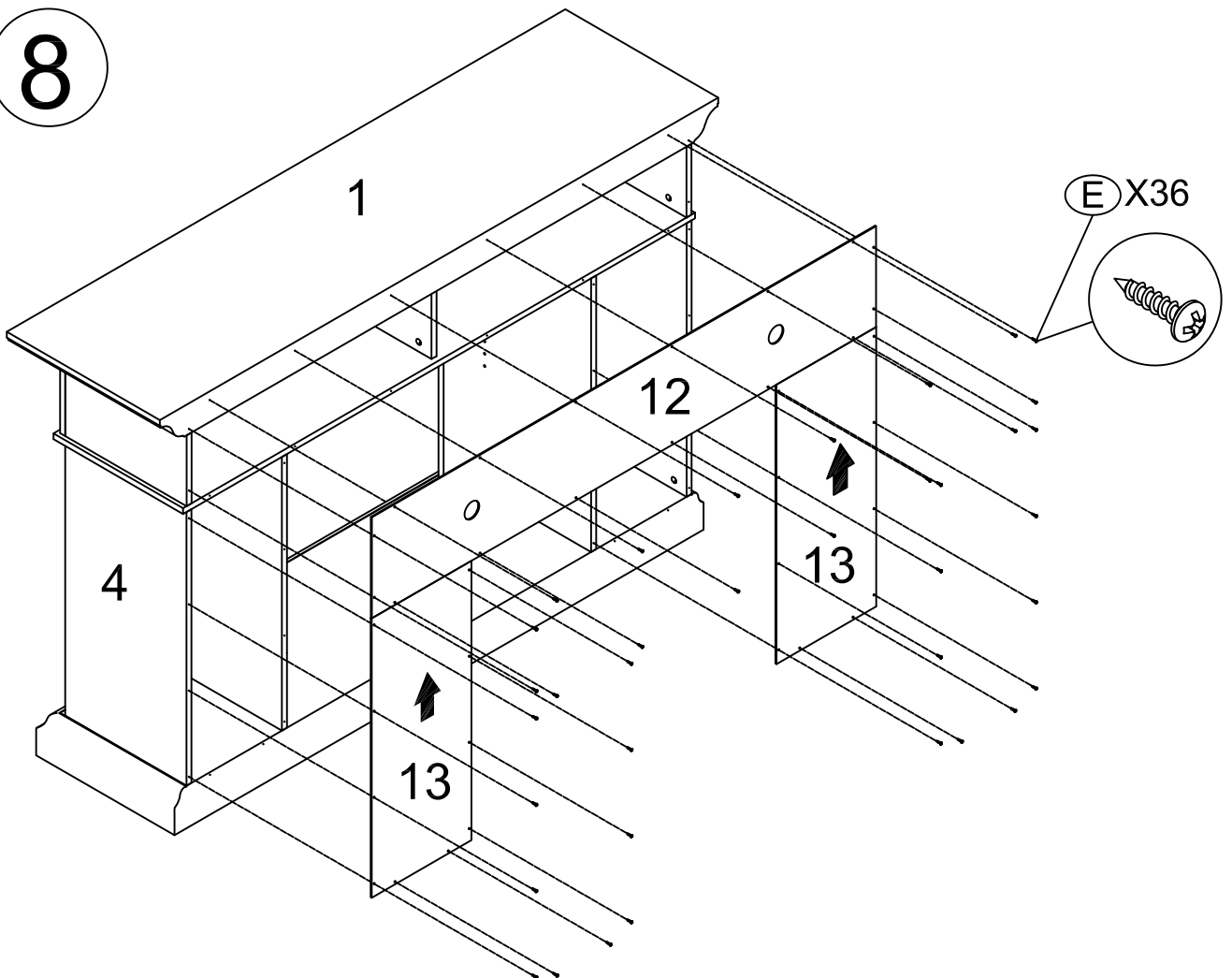

9

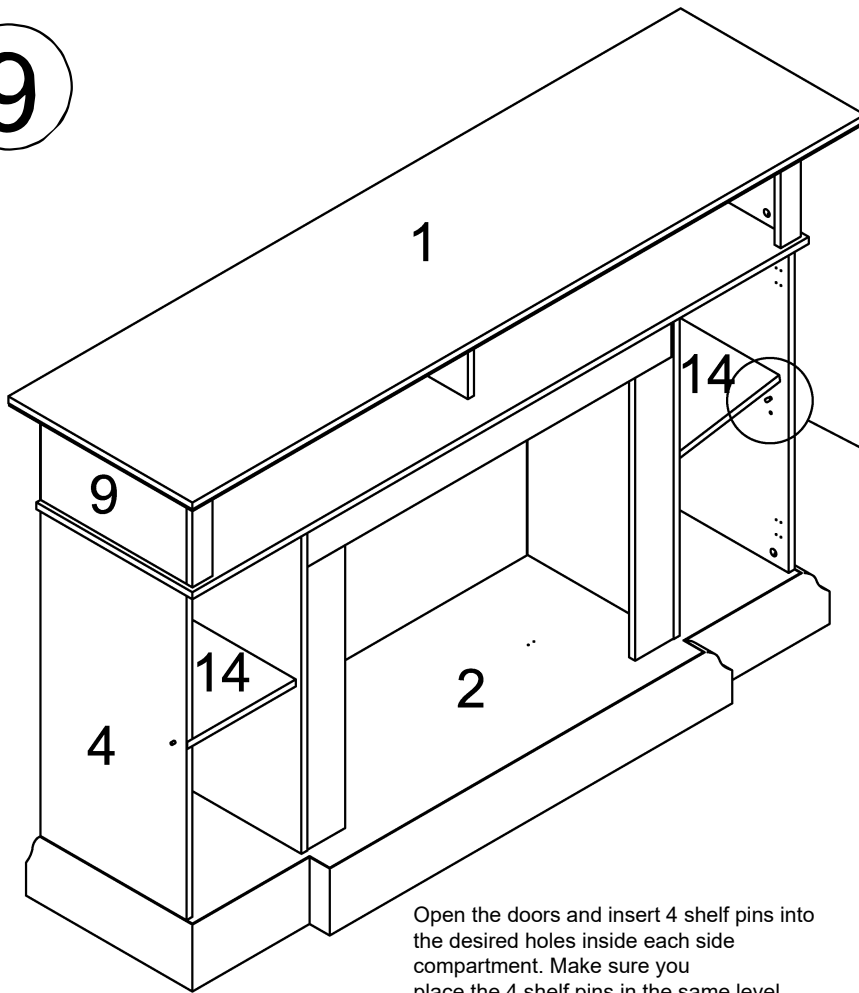

Open the doors and insert 4 shelf pins into the desired holes inside each side compartment. Make sure you place the 4 shelf pins in the same level so the shelf is not tilted. Rest the adjustable shelves onto the shelf pins.

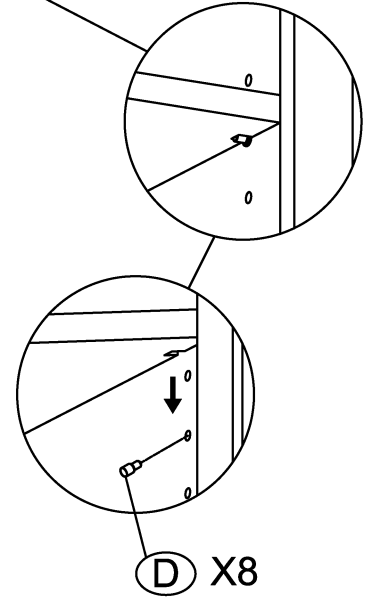

10

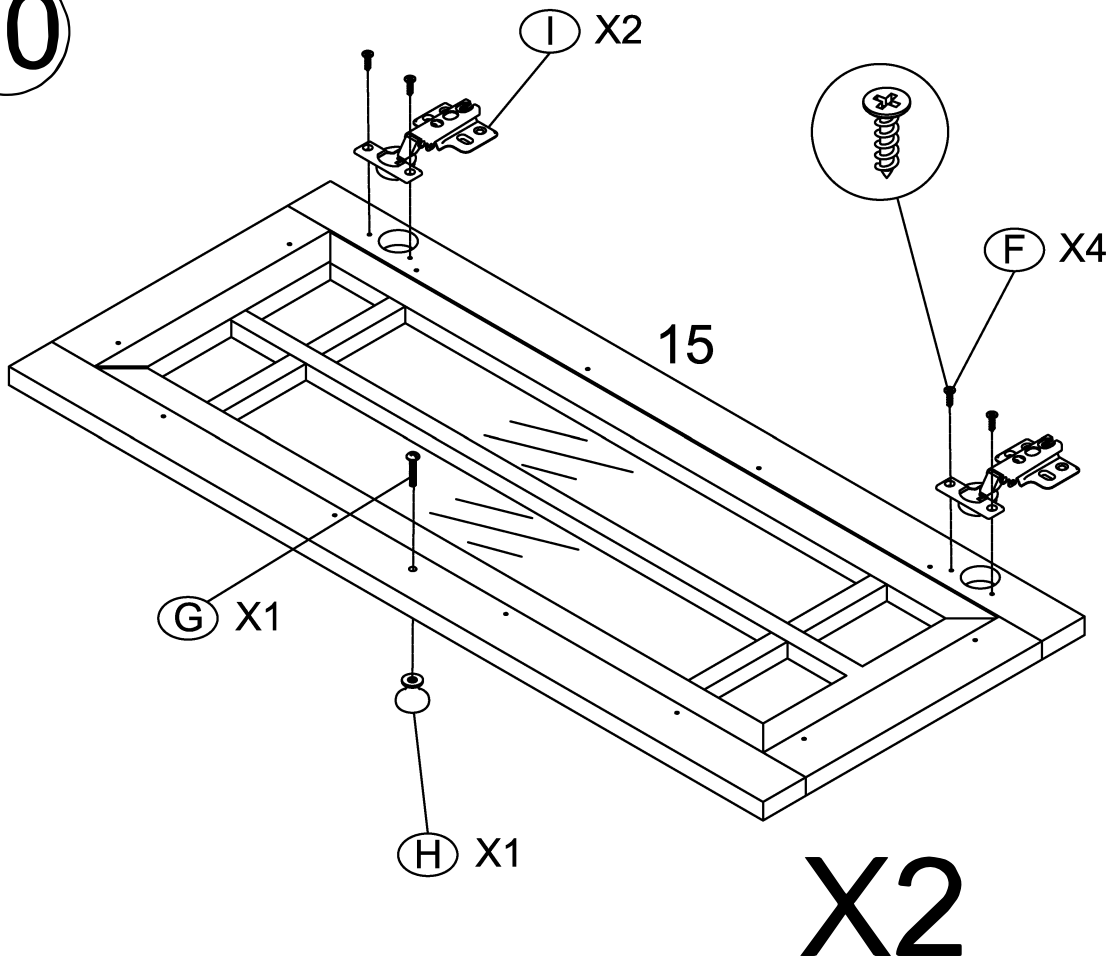

11

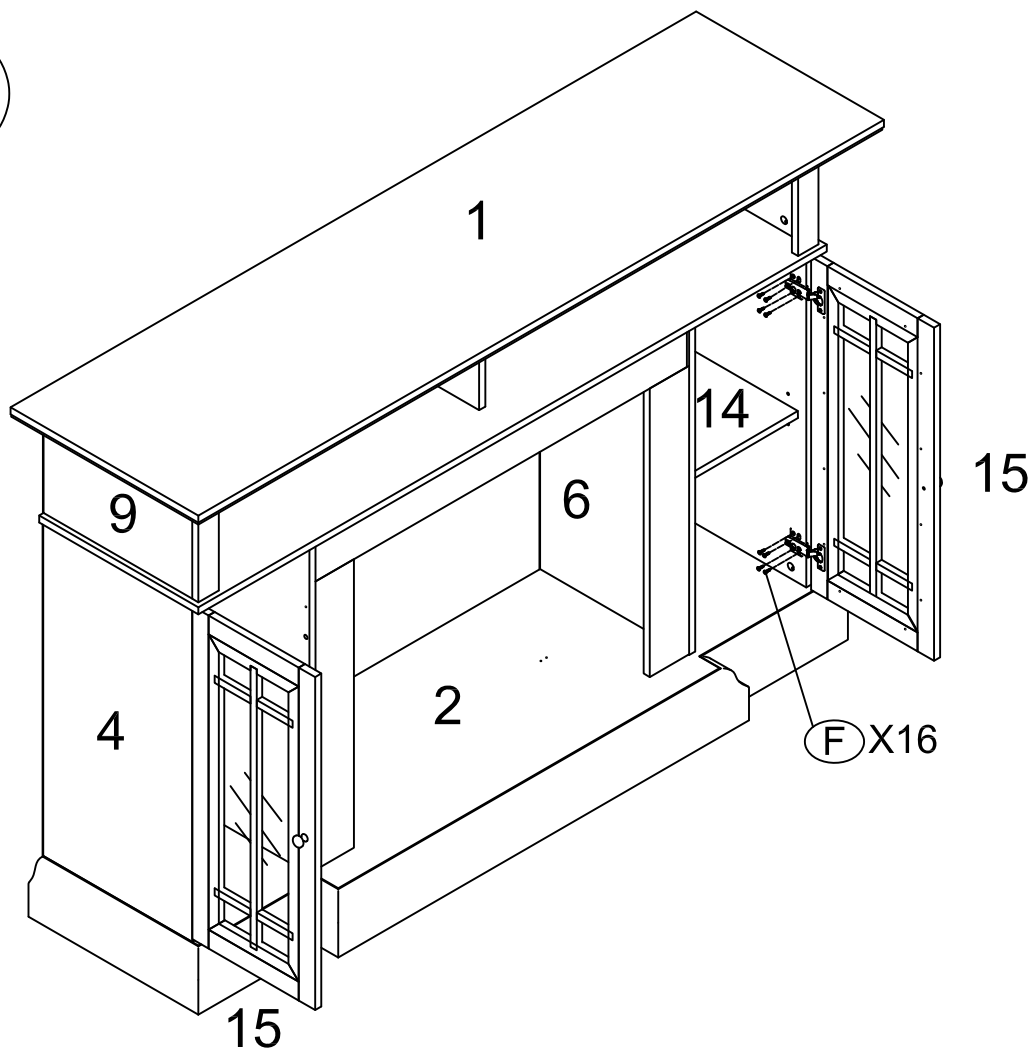

LIMITED WARRANTY

This warrants to the original purchaser that this product is free from defects in material and workmanship as of the date of purchase and that it will, under normal use and proper care, remain so for 1 year from the date of purchase. Missing or initially defective parts will be replaced free of charge during the period of this limited warranty. If parts are unavailable, comparable replacement or refund will be given. The original dated sales receipt is required for all warranty claims. This warranty does not cover damage which has occurred during transport from the point of purchase to the consumer's home.

This mantle or cabinet is for residential use only. Any and all commercial use of this product voids all warranties, and frees the manufacturer from all liability. Read and fully understand all assembly and operating instructions, and all safety information and warnings, before use. The following will void this warranty: damage caused by tampering with, modifying, or altering the mantle or cabinet in any manner; damage due to incorrect assembly, improper care, misuse, or abuse; damage from being used with the wrong products; water damage; damage caused from being used outdoors; damage caused from an electric fireplace being used for excessive periods of time when in use with mantle or cabinet; damage caused by being used in any commercial application; other misuse and abuse not specifically listed herein.

This mantle or cabinet is not intended to be used with a combustible heat source. It's directors, officers, or agents, will not be liable to the purchaser or any third party, whether in contract, in tort, or on any other basis, for any indirect, special, punitive, exemplary, consequential, or incidental loss, cost, or damage arising out of or in connection with this sale, maintenance, use, or inability to use this product, even if its directors, or agents have been advised of the possibility of such losses, costs, or damages that exceed the purchase price of the product. Some states do not allow the exclusion or limitation of incidental or consequential damages, so the above limitation or exclusion may not apply to the purchaser. This limited warranty gives you specific legal rights, and you may also have other rights, which vary from state-to-state.