

Vanity Desk with Hutch

Assembly Instructions

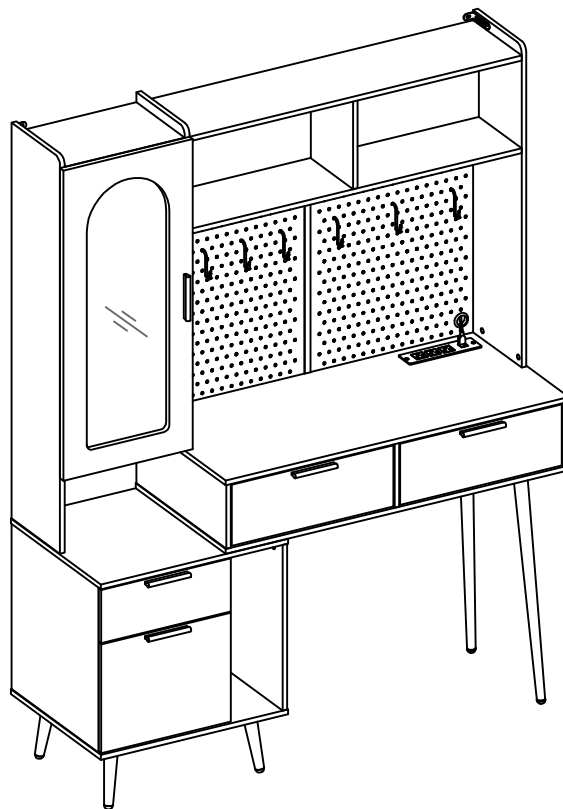



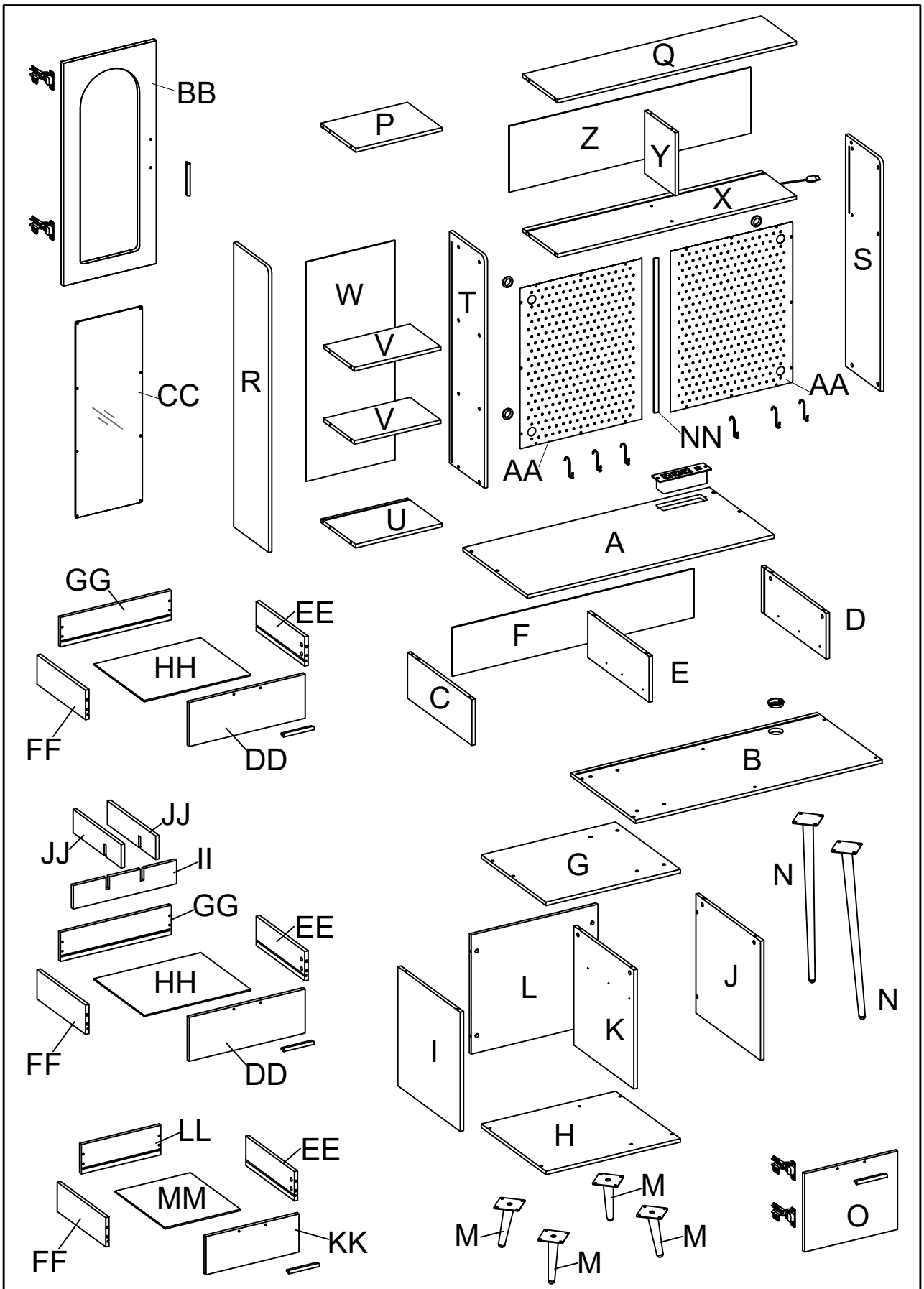

Attention: Please ensure you have all parts before commencing assembly.
Please read all the instructions before commencing.



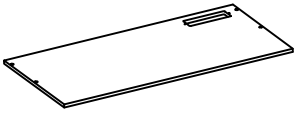
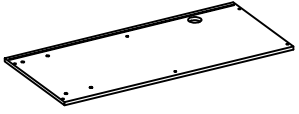
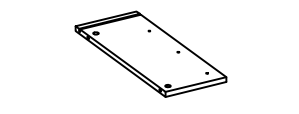
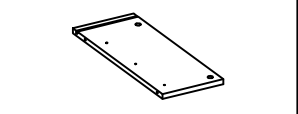
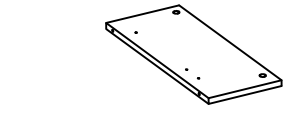
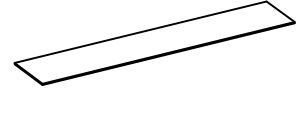
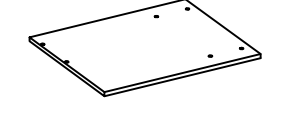
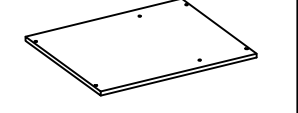
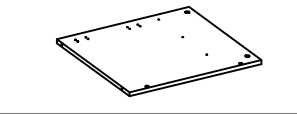
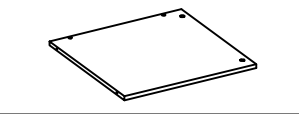
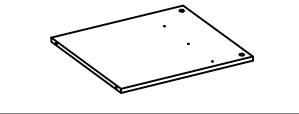
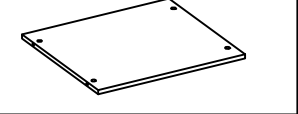

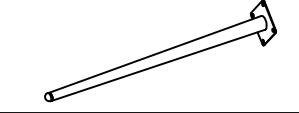
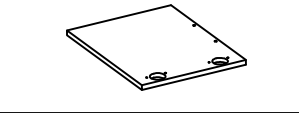
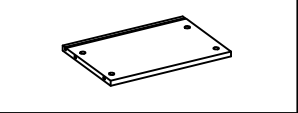
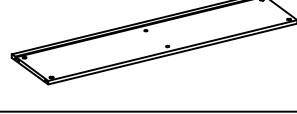
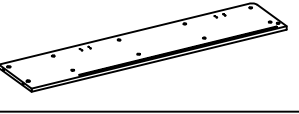
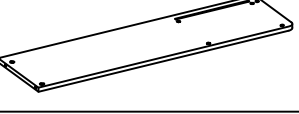
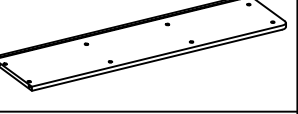
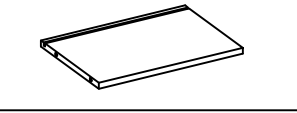
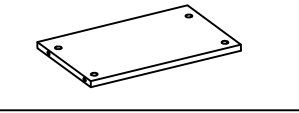

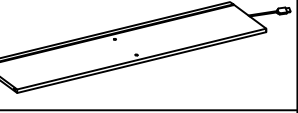
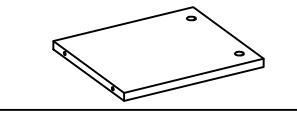
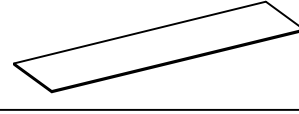
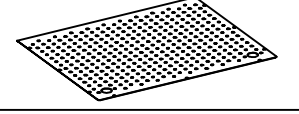
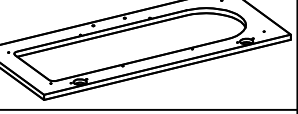
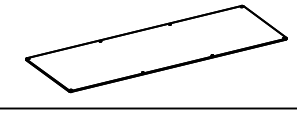
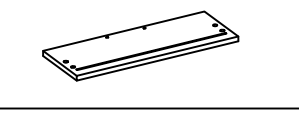
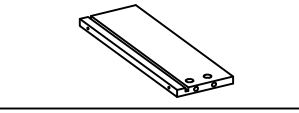
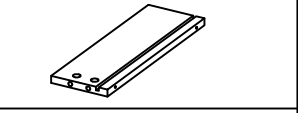
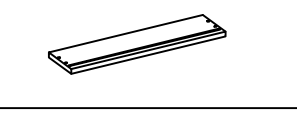
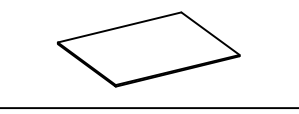
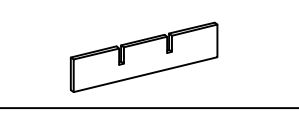
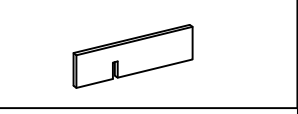
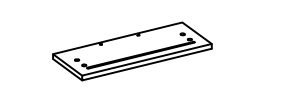
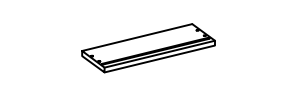
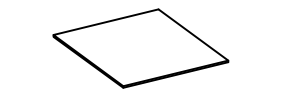
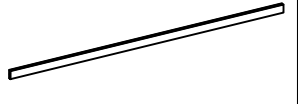



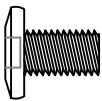
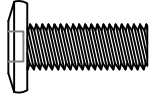
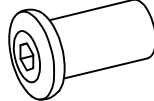

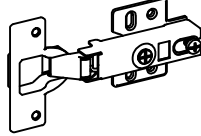
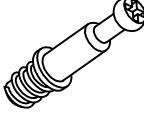





PART LIST

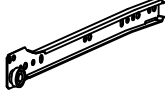
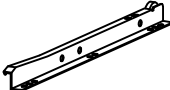

PART LIST

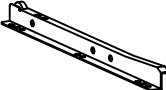
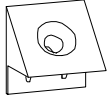
A x 1pc 	B x 1pc 	C x 1pc 	D x 1pc 
E x 1pc 	F x 1pc 	G x 1pc 	H x 1pc 
I x 1pc 	J x 1pc 	K x 1pc 	L x 1pc 
M x 4pcs 	N x 2pcs 	O x 1pc 	P x 1pc 
Q x 1pc 	R x 1pc 	S x 1pc 	T x 1pc 
U x 1pc 	V x 2pcs 	W x 1pc 	X x 1pc 
Y x 1pc 	Z x 1pc 	AA x 2pcs 	BB x 1pc 
CC x 1pc 	DD x 2pcs 	EE x 3pcs 	FF x 3pcs 
GG x 2pcs 	HH x 2pcs 	II x 1pc 	JJ x 2pcs 
KK x 1pc 	LL x 1pc 	MM x 1pc 	NN x 1pc 

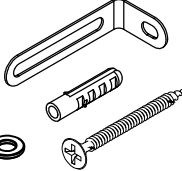
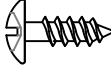
HARDWARE LIST

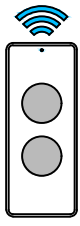
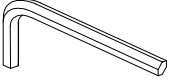
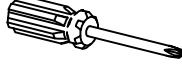
①  M6x10 24 pcs	②  M6x16 4 pcs	③  M6x15 4 pcs	④  Ø45mm 1 pc
⑤  4 pcs	⑥  4 pcs	⑦  M6x28 60 pcs	⑧  Ø12 60 pcs
⑨  M6x40 14 pcs	⑩  M3x12 104 pcs	⑪  1 pc	⑫  M4x12 18 pcs
⑬  M4x15 8 pcs	⑭  M4x18 2 pcs	⑮  5 pcs	⑯  M4x30 12 pcs
⑰  300L 3 pcs	⑱  300L 3 pcs	⑲  300L 3 pcs	⑳  300L 3 pcs
㉑  42 pcs	㉒  6 pcs	㉓  M4x40 2 pcs	㉔  M3.5x12 8 pcs
㉕  M6x8 2 pcs	㉖  RF Remote Control 1 pc	㉗  M4 2 pcs	㉘  1 pc

Please count and verify all parts before assembly .

How to install Camlocks

Connect the male camlock as directed in the assembly instructions with a screwdriver.

1 DO NOT OVER TIGHTEN

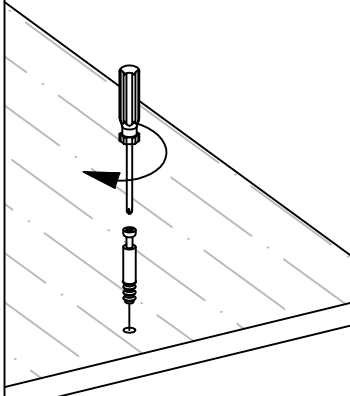

Put the male camlock into the entry hole.

2

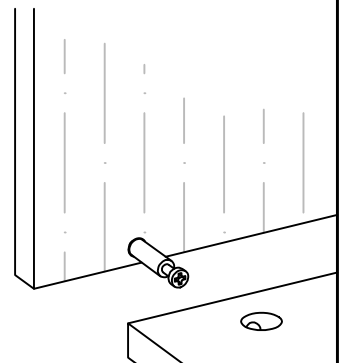

Insert the female camlock as shown in the instruction.

Note: ensure that the arrow on the top of the camlock points toward the entry hole for the male camlock.

3

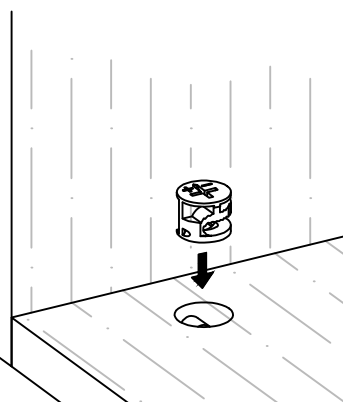

Screw the female camlock clockwise with a screwdriver.

You will feel a click when the camlock is locked in place.

The camlock is now completed.

4

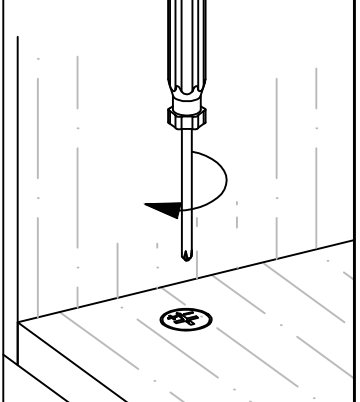

HOW TO ADJUST THE EUROPEAN ADJUSTABLE HINGES ON DOOR

If the doors require adjustment, follow the below options as needed:

To adjust door up or down, loosen screws (a), adjust door and retighten screws.

To adjust door left and right, turn screw (b) in or out.

To adjust door in and out, loosen screw (c), adjust door and retighten screw.

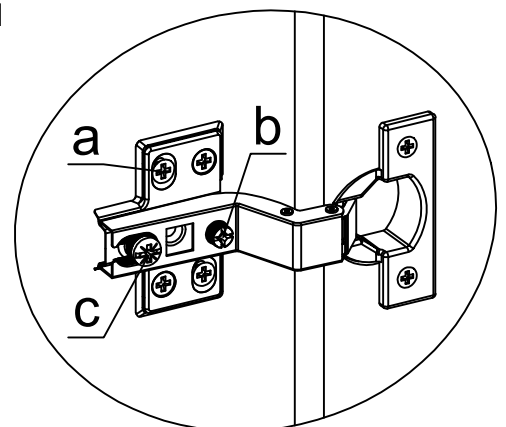

STEP 1

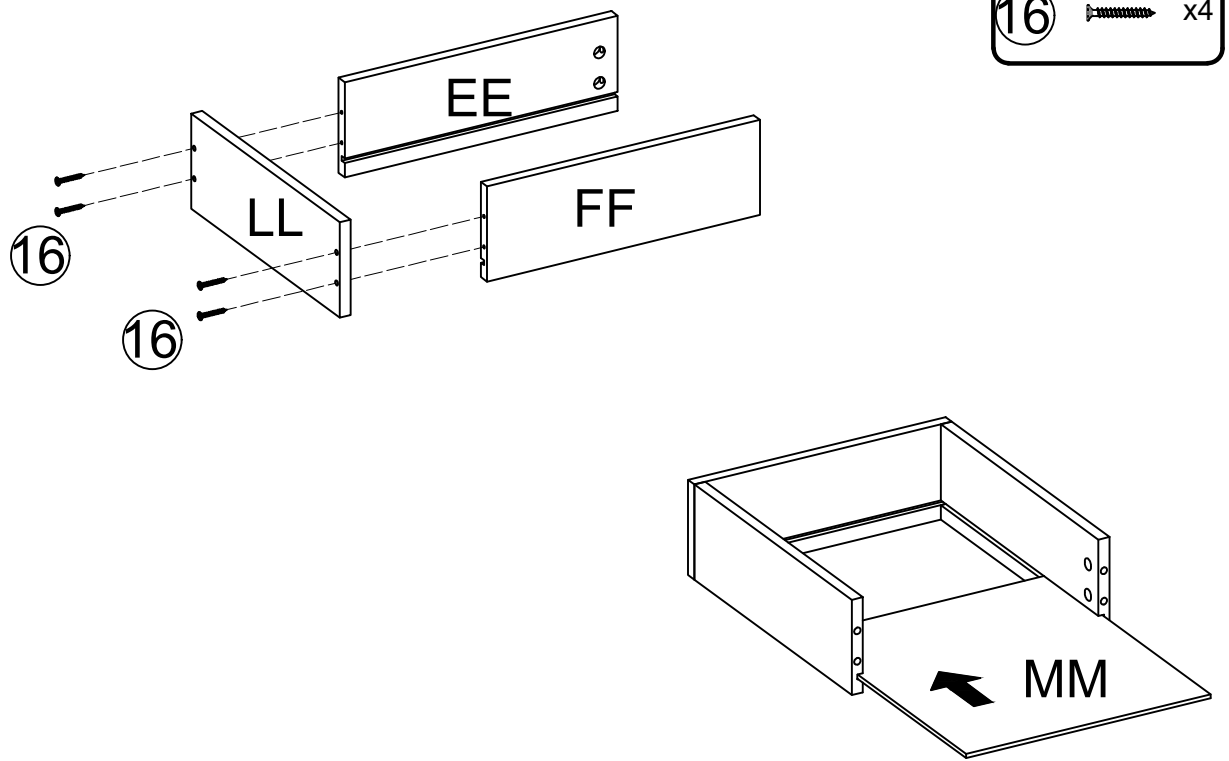

STEP 2

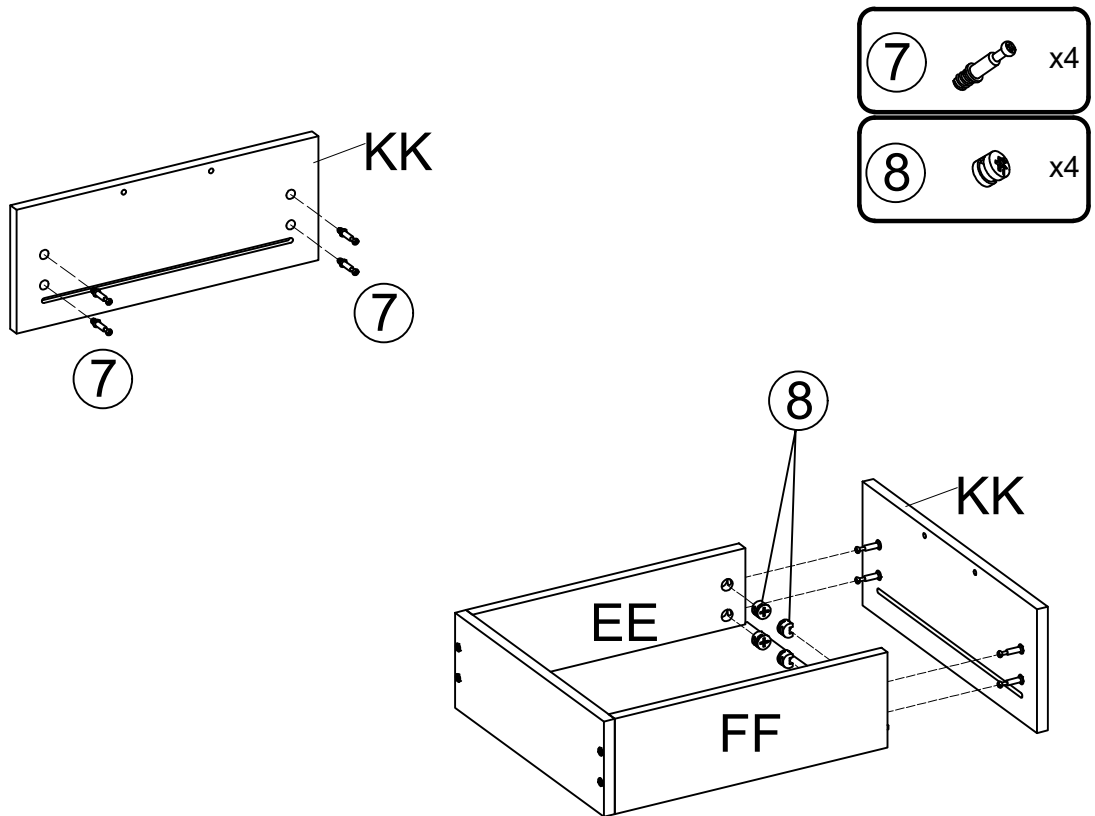

STEP 3

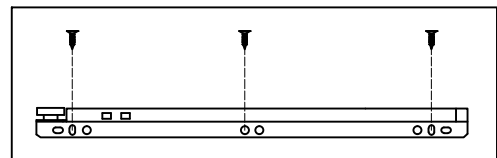
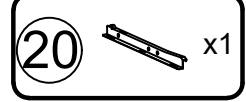
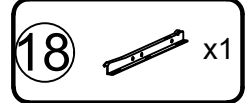
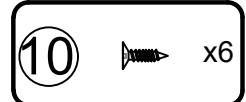
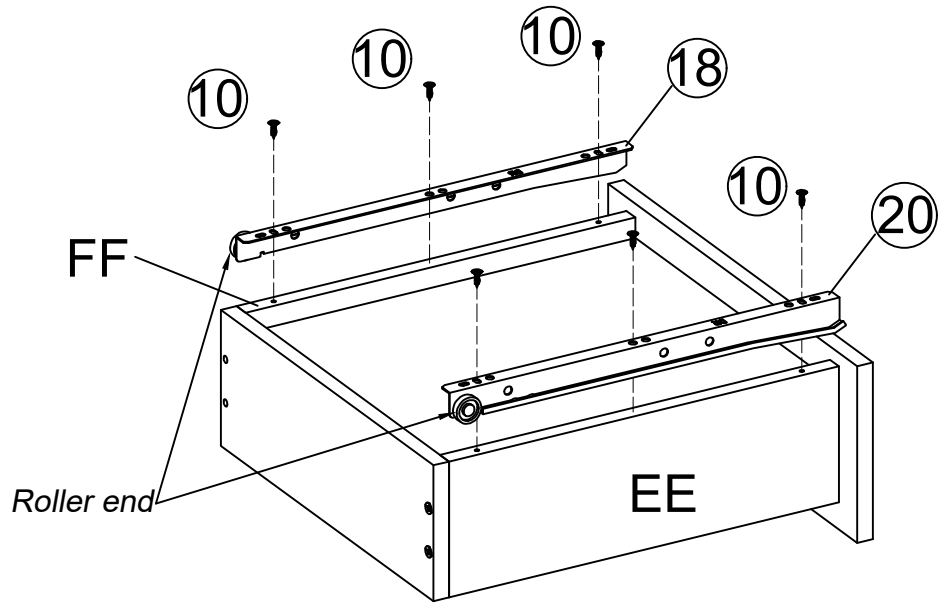

STEP 4

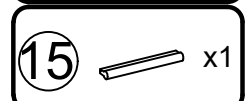
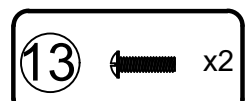
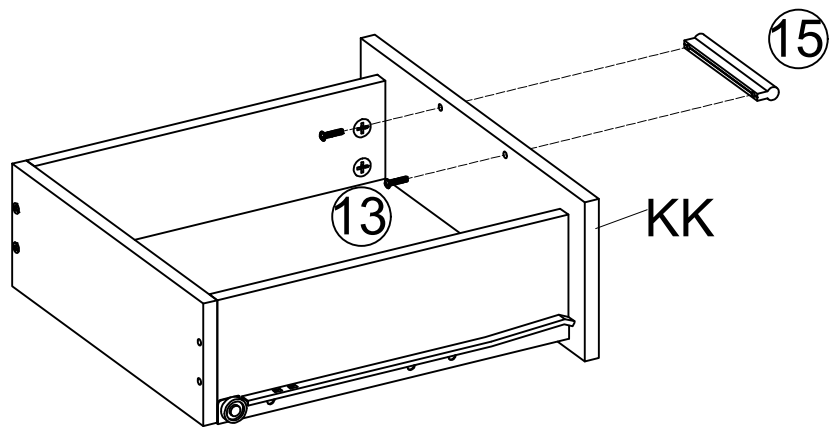

STEP 5

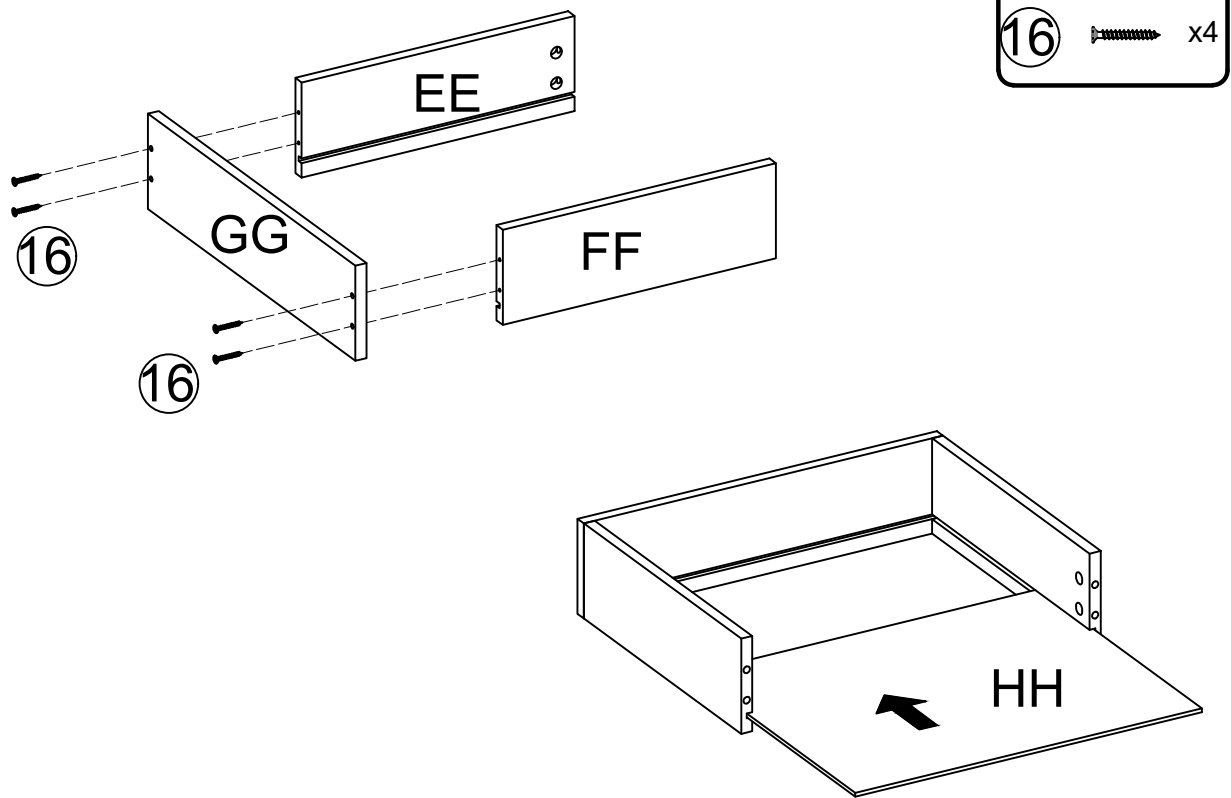

STEP 6

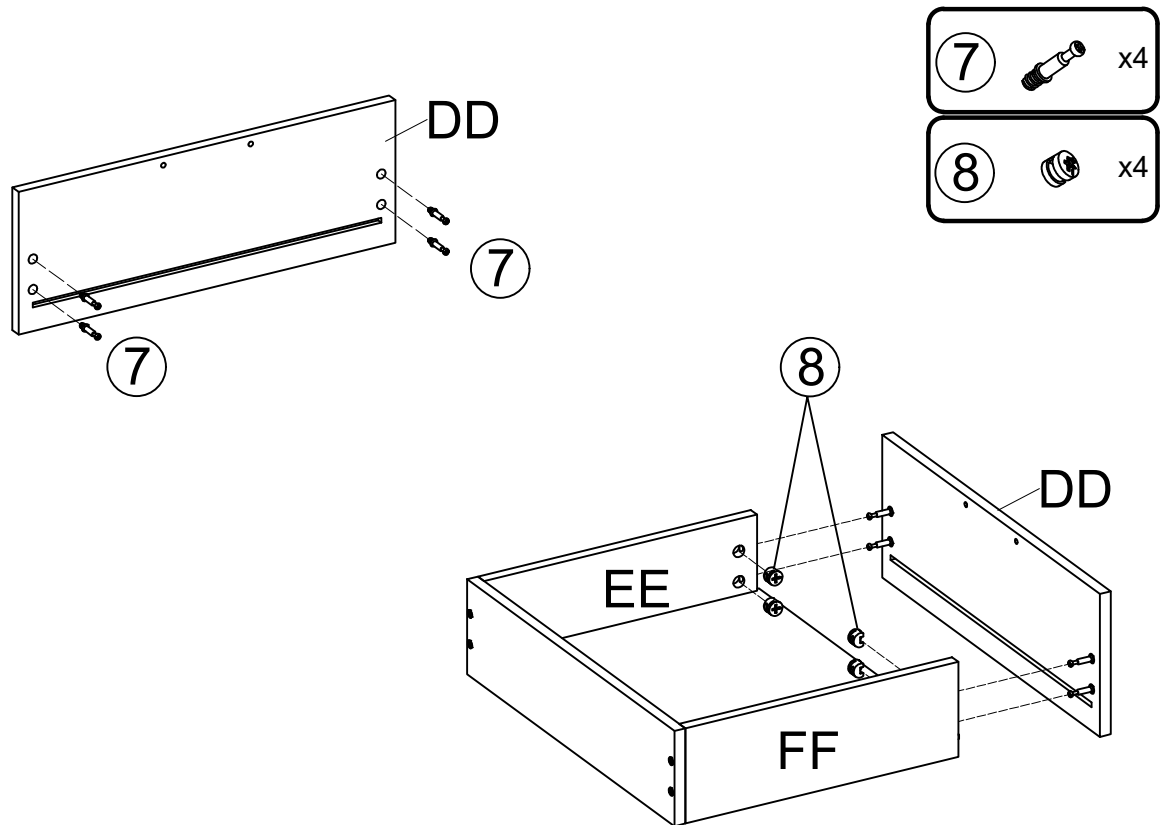

STEP 7

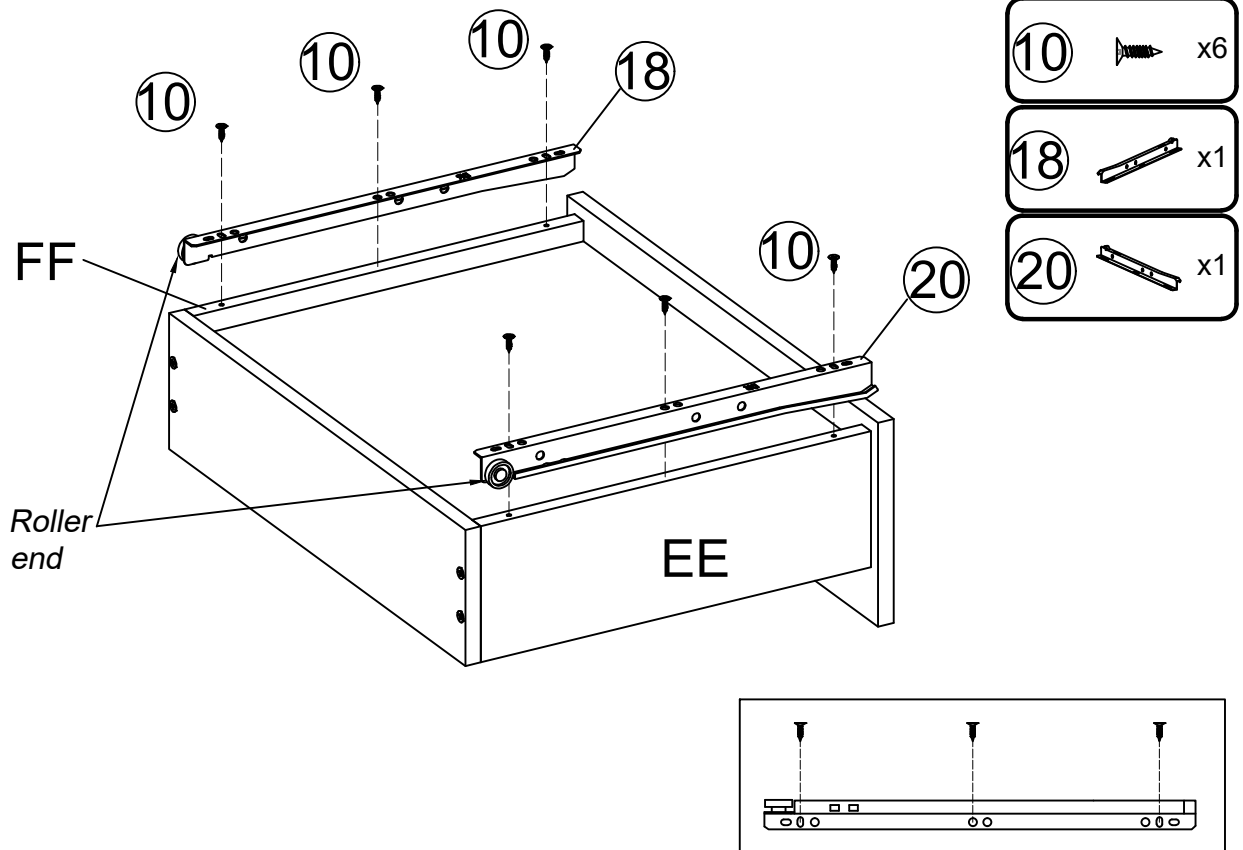

STEP 8

NOTICE:
The installation for all the two upper cabinet drawers is base on the 5-8 steps above.

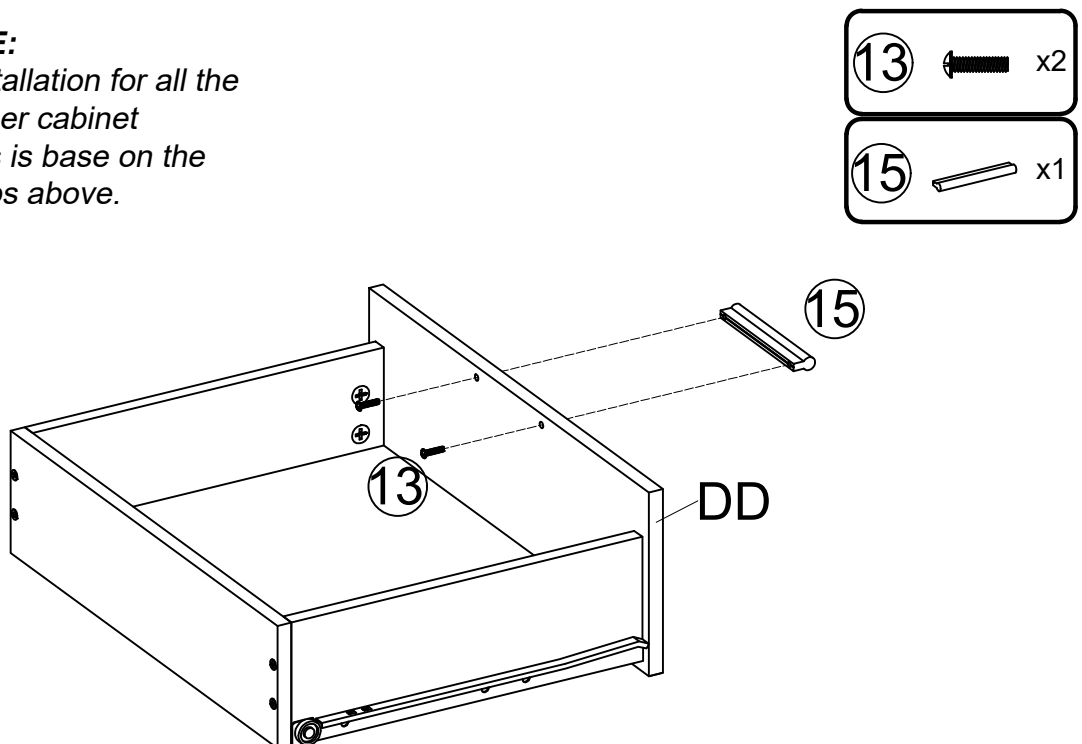

STEP 9

You can choose whether to install Part II and JJ or not according to your needs.

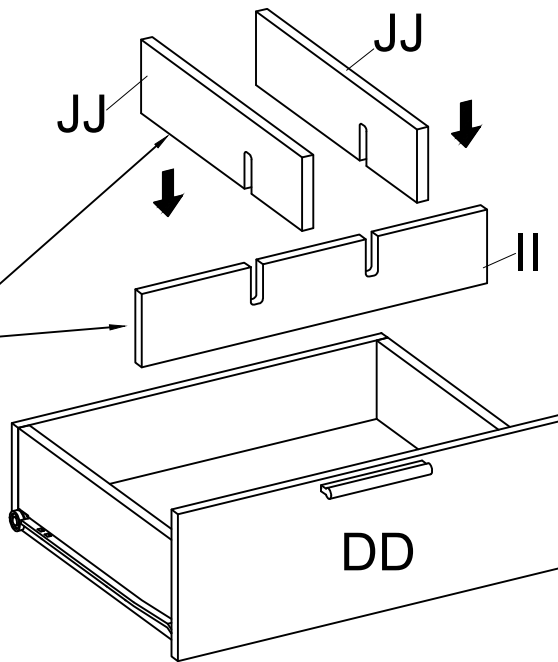

STEP 10

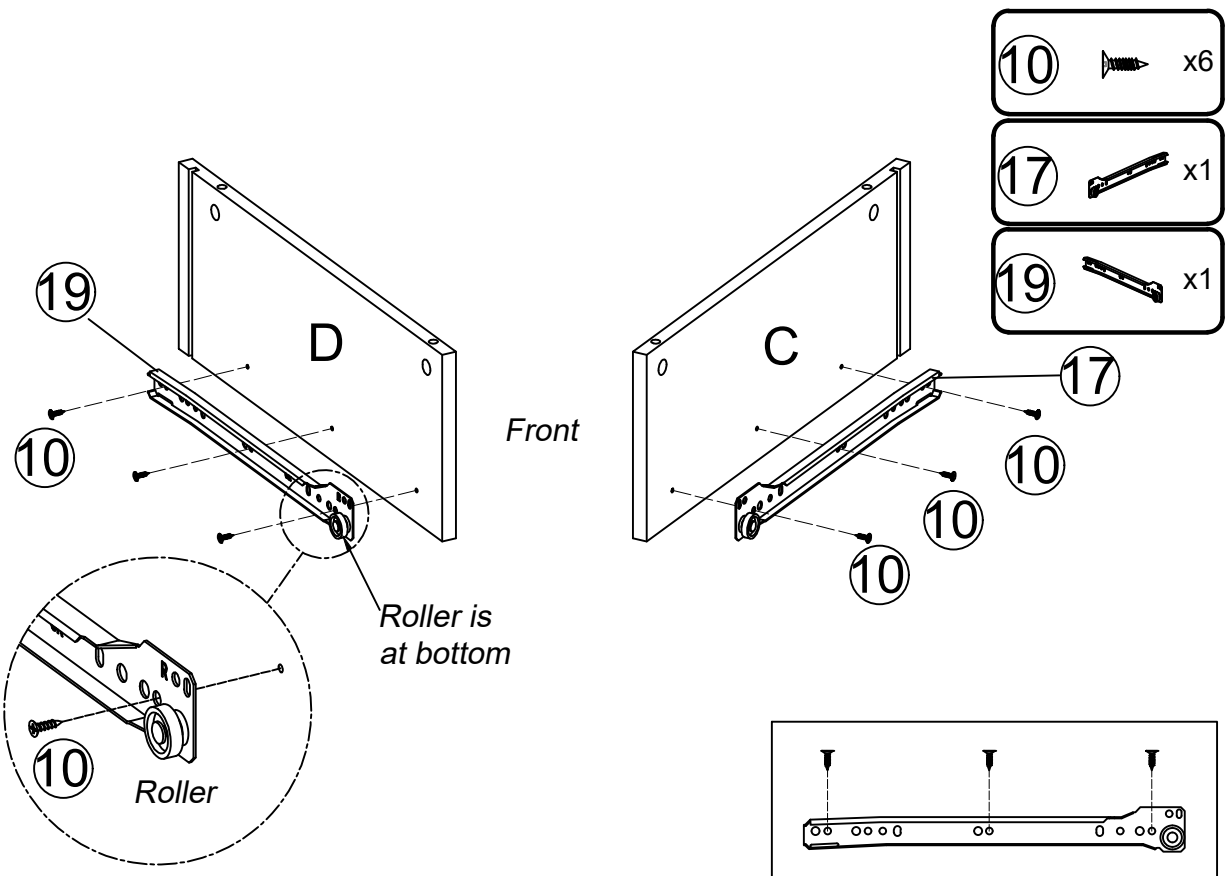

STEP 11

Please pay attention to the screws position of the slide track.

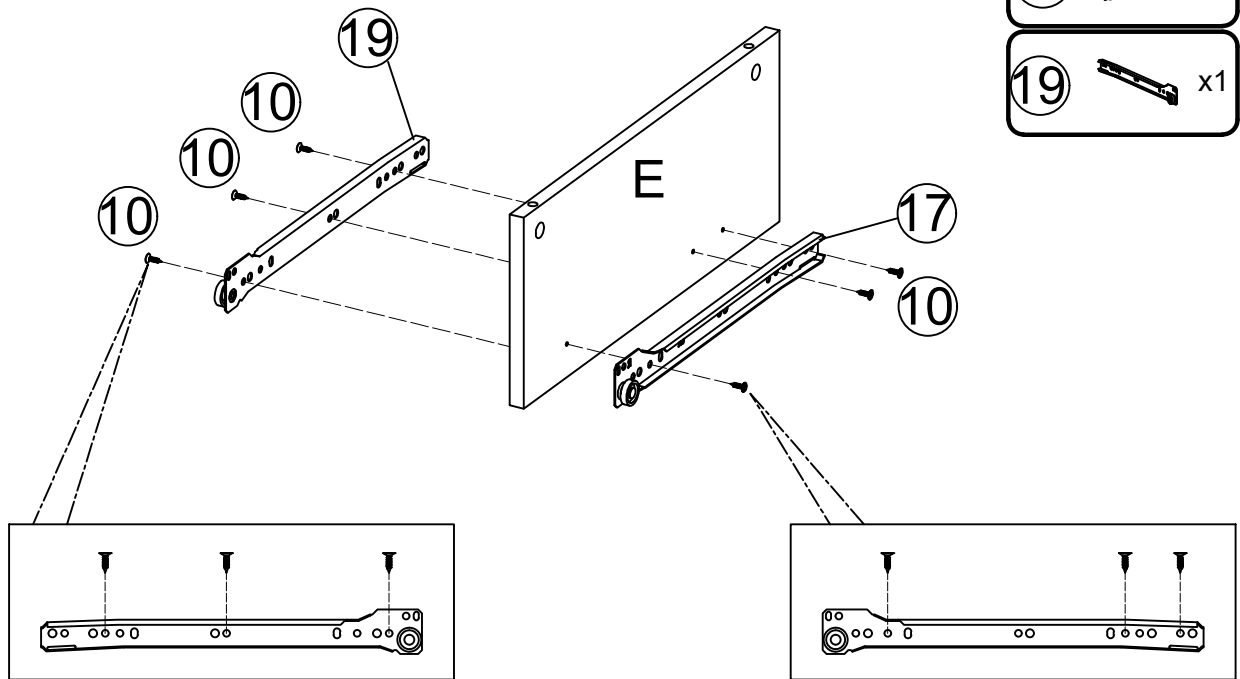

STEP 12

Keep the holes of the Part E toward this direction as shown

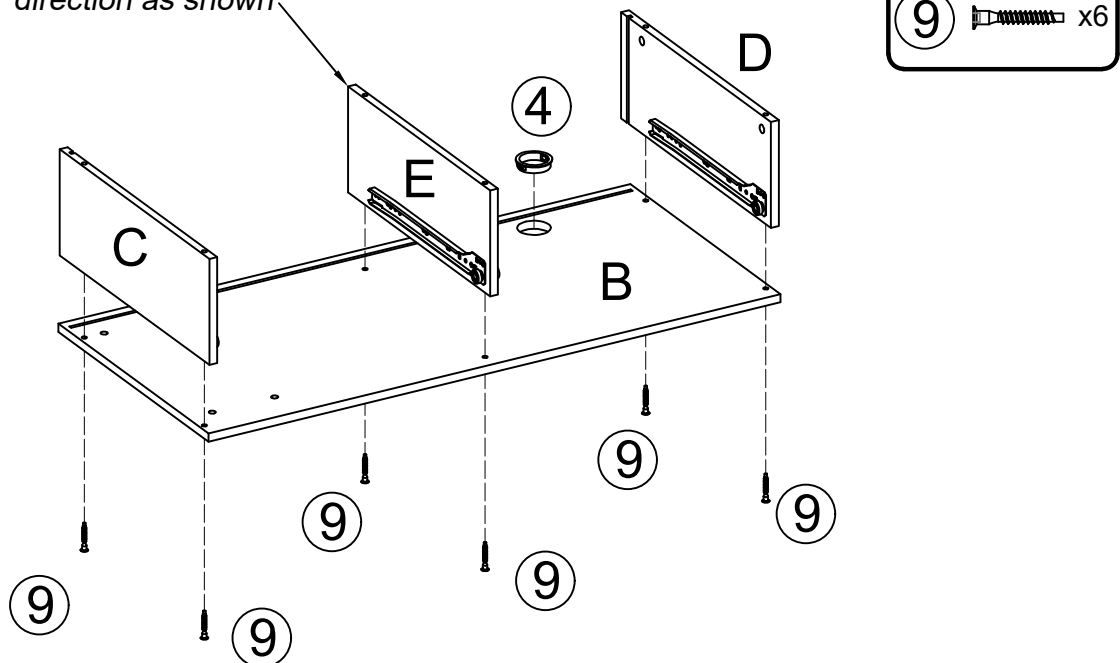

STEP 13

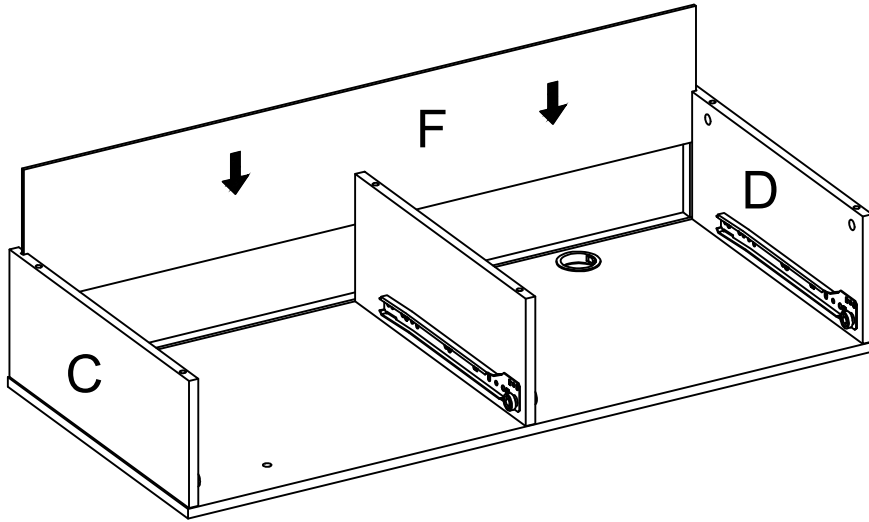

STEP 14

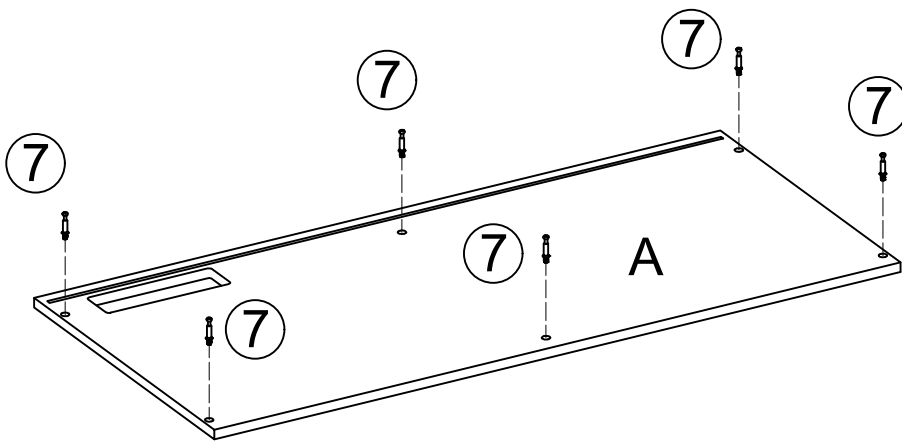
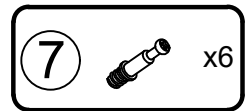

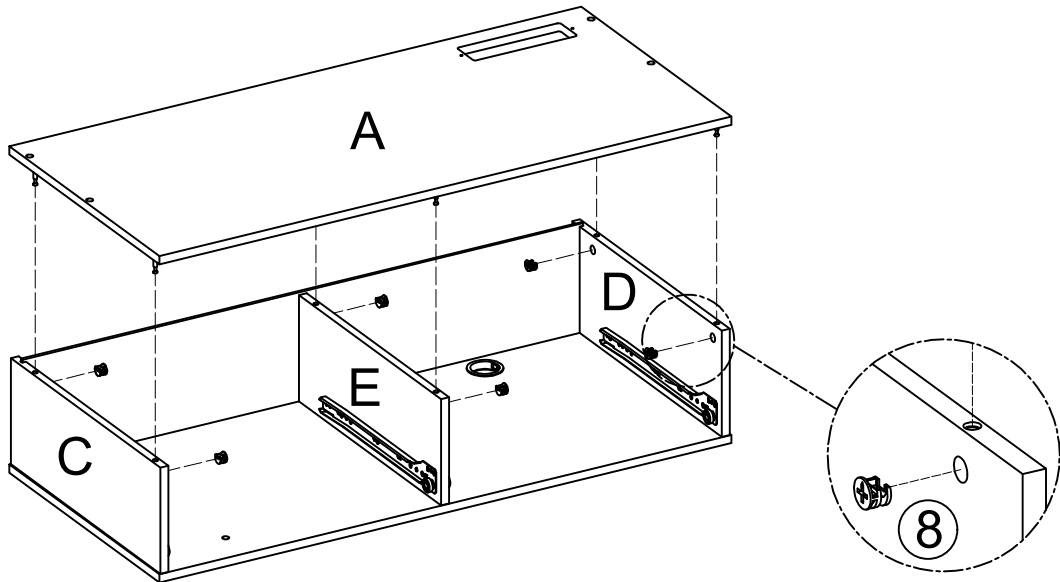

STEP 15

- 8  x6



STEP 16

- 10  x6
- 17  x1
- 19  x1

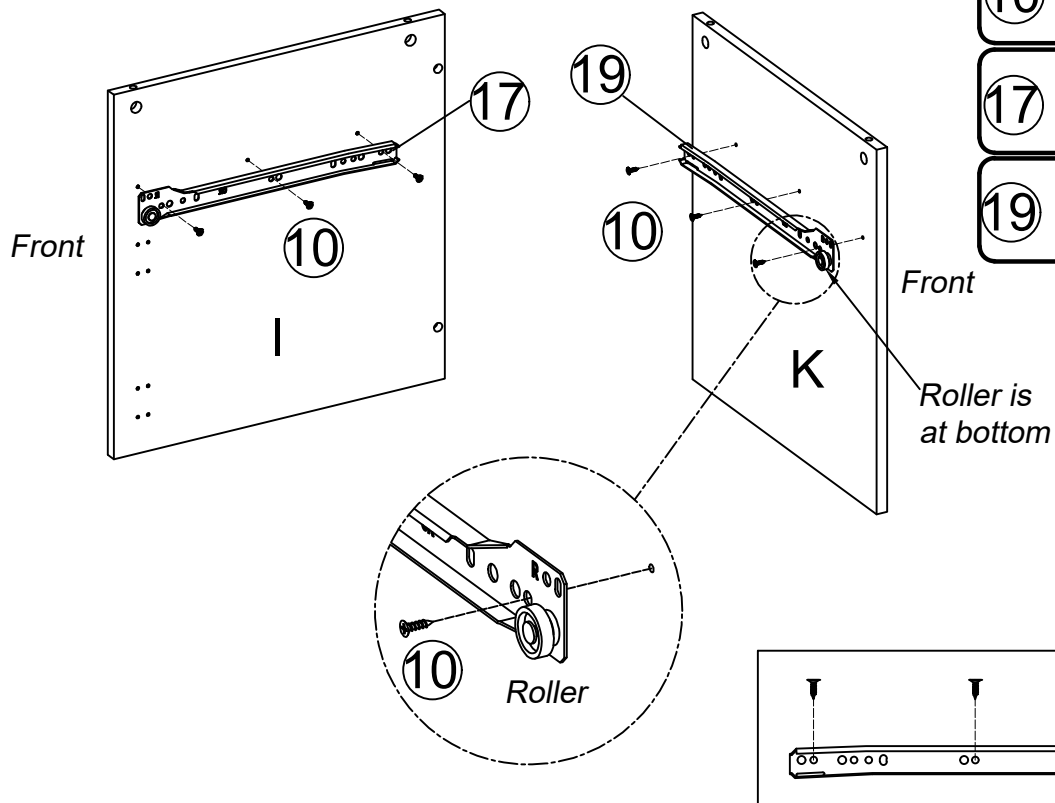

STEP 17

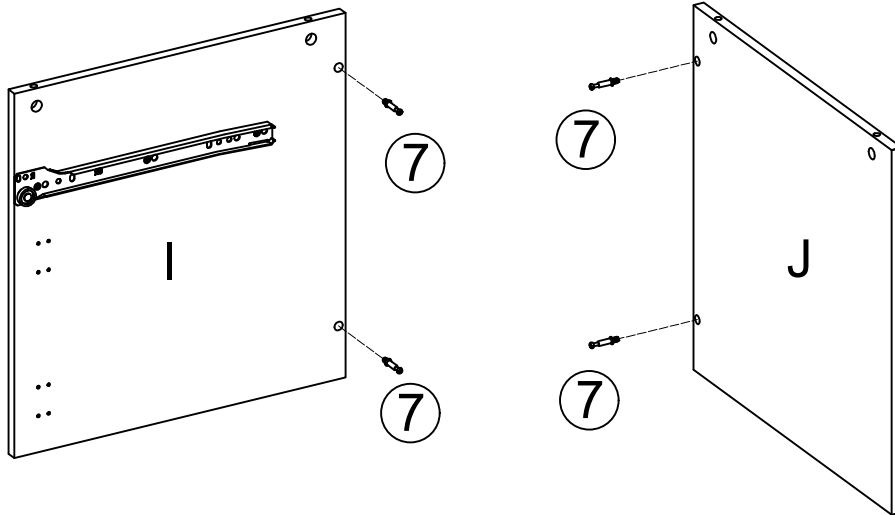
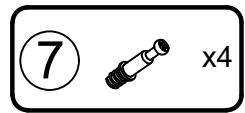

STEP 18

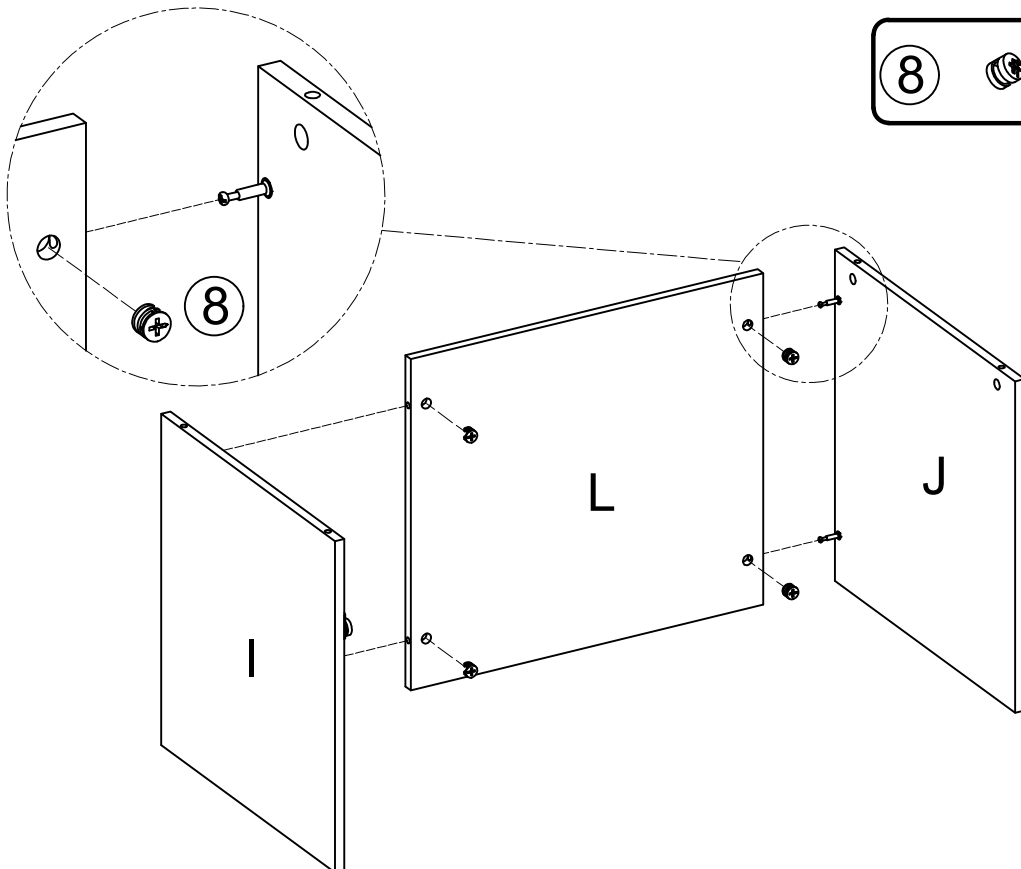
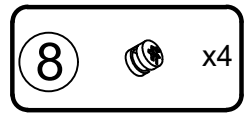

STEP 19

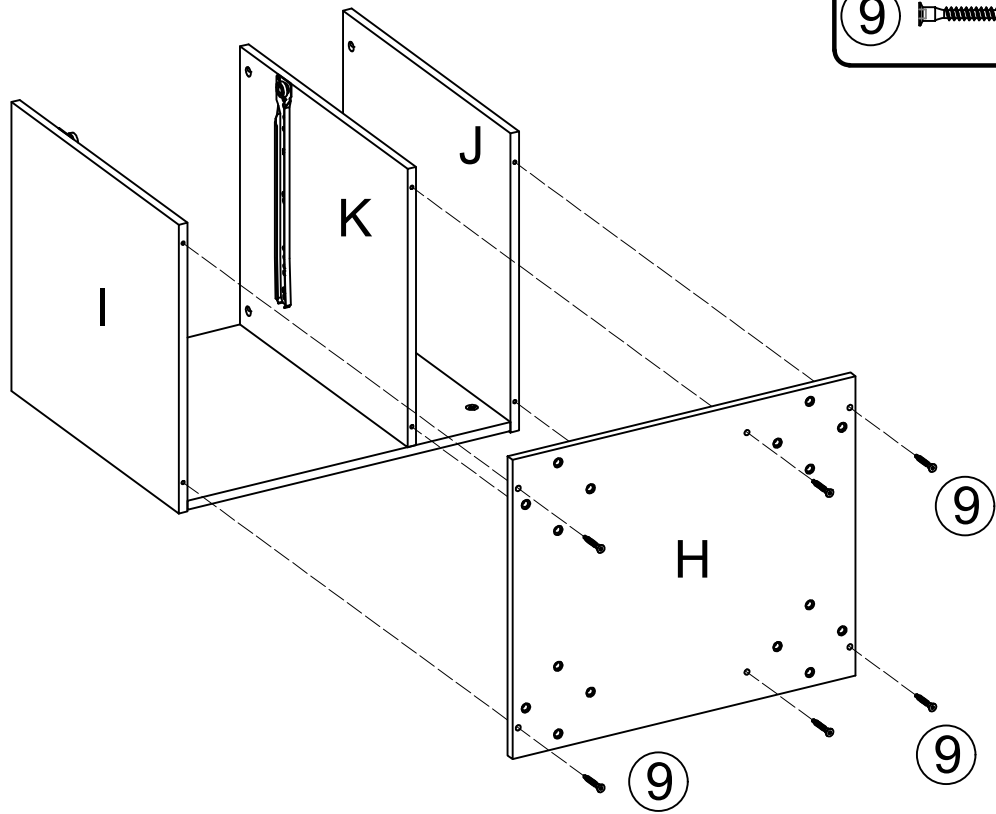
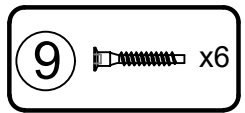

STEP 20

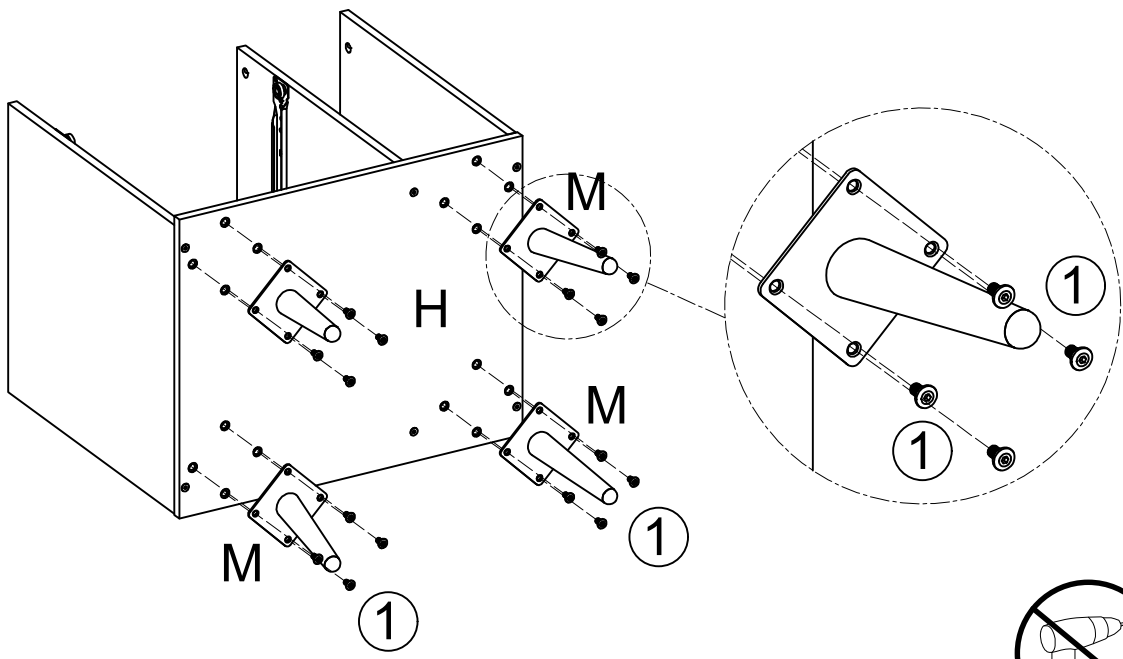
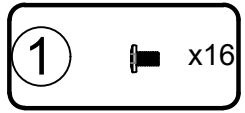

STEP 21

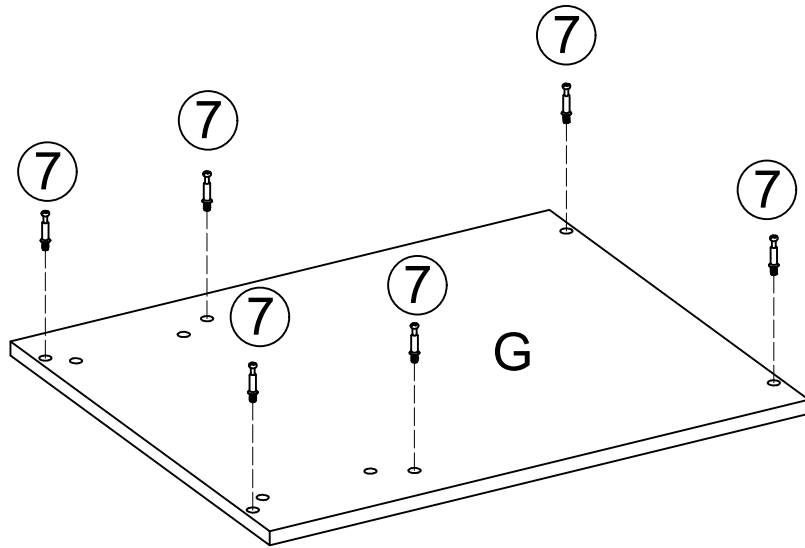
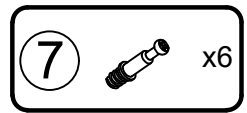

STEP 22

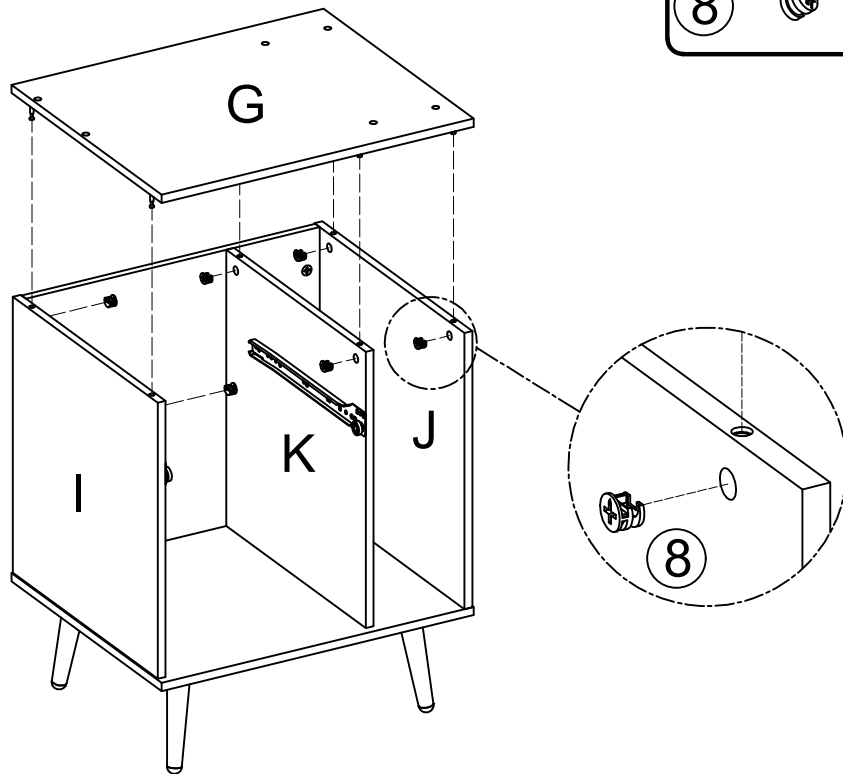
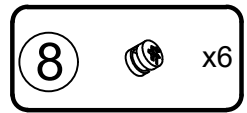

STEP 23

Please ensure that using the correct screws for panel assembly. Using the wrong screw will cause a cracked panel.

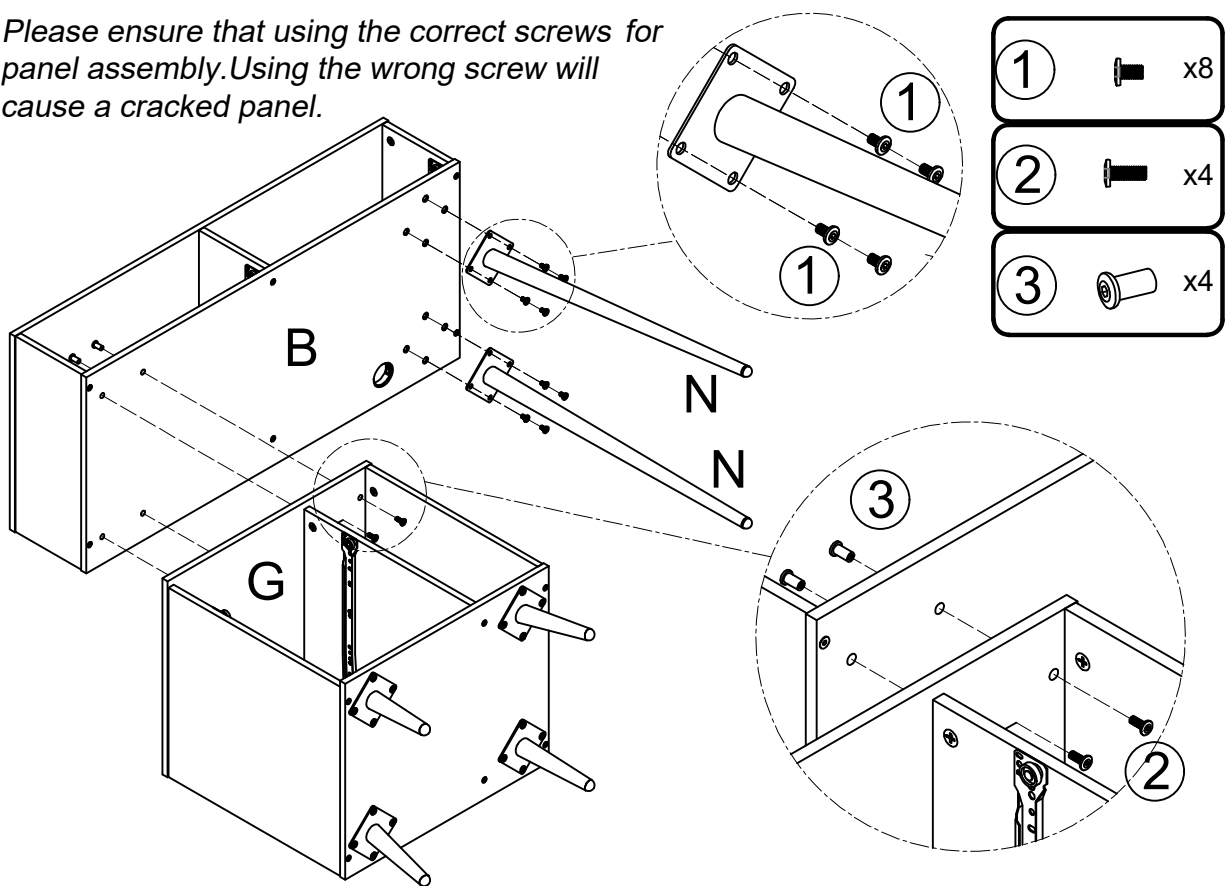

STEP 24

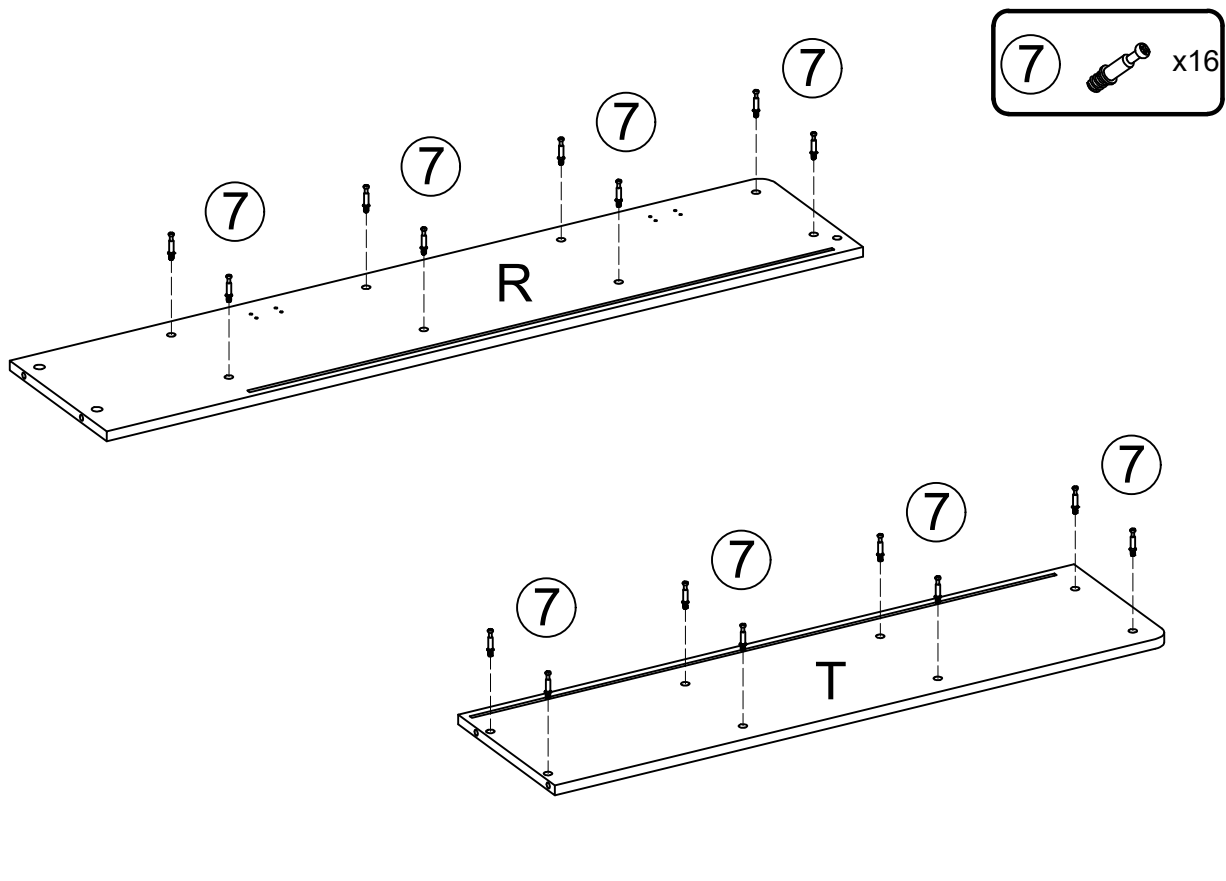

STEP 25

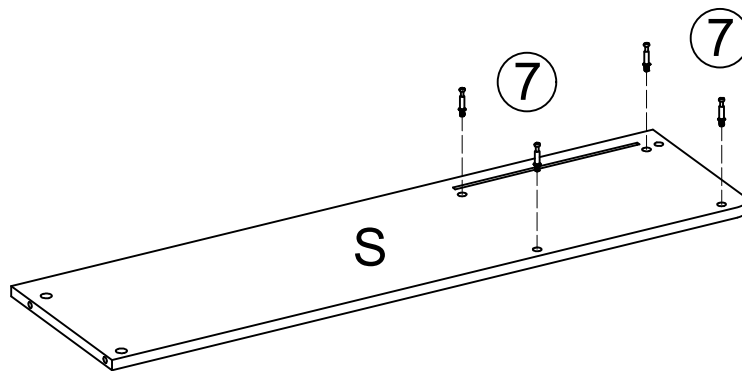
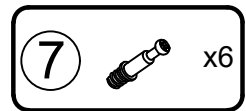
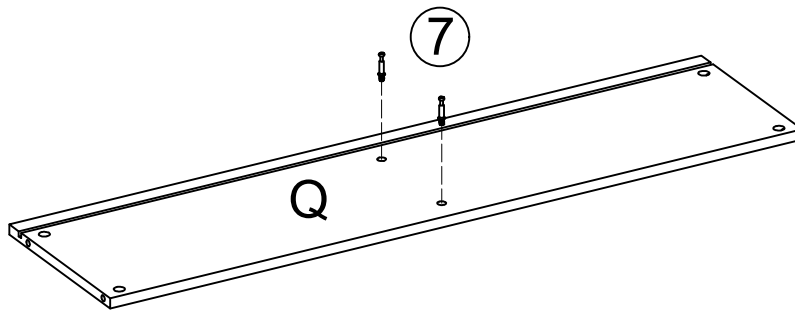

STEP 26

Keep the holes of the Part P and Part U toward this direction as shown

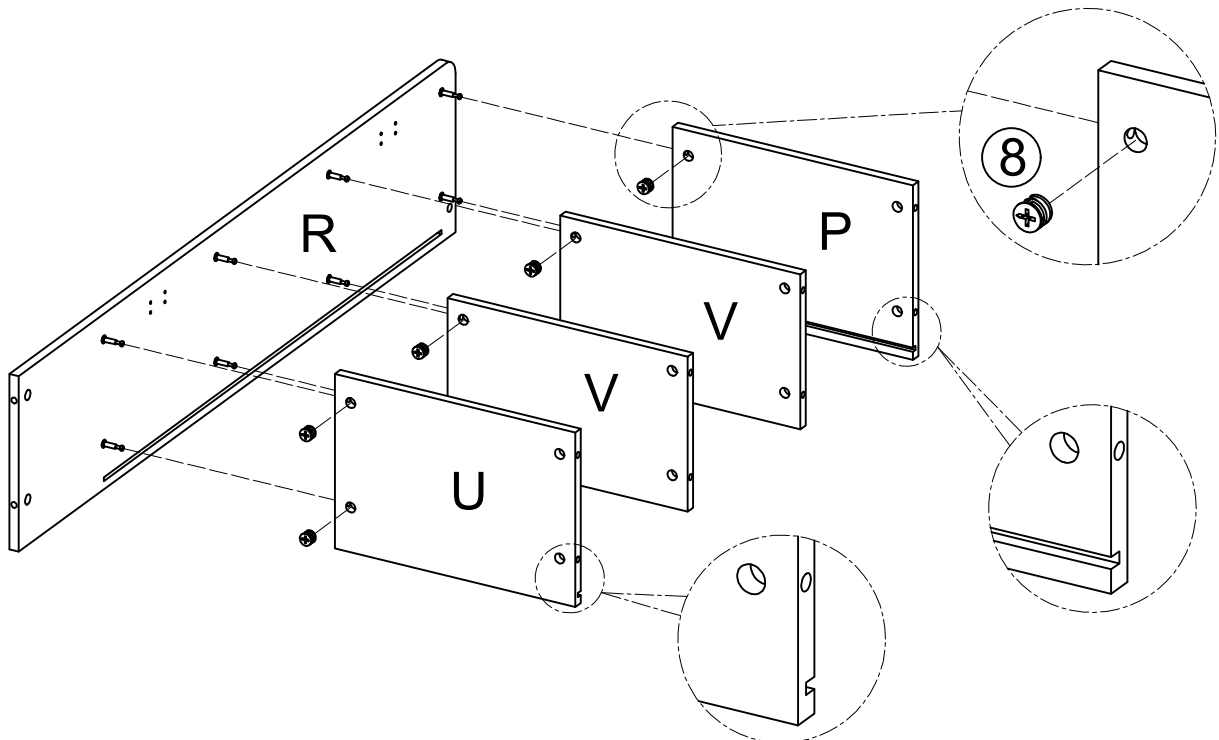
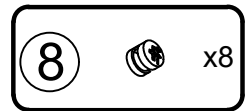

STEP 27

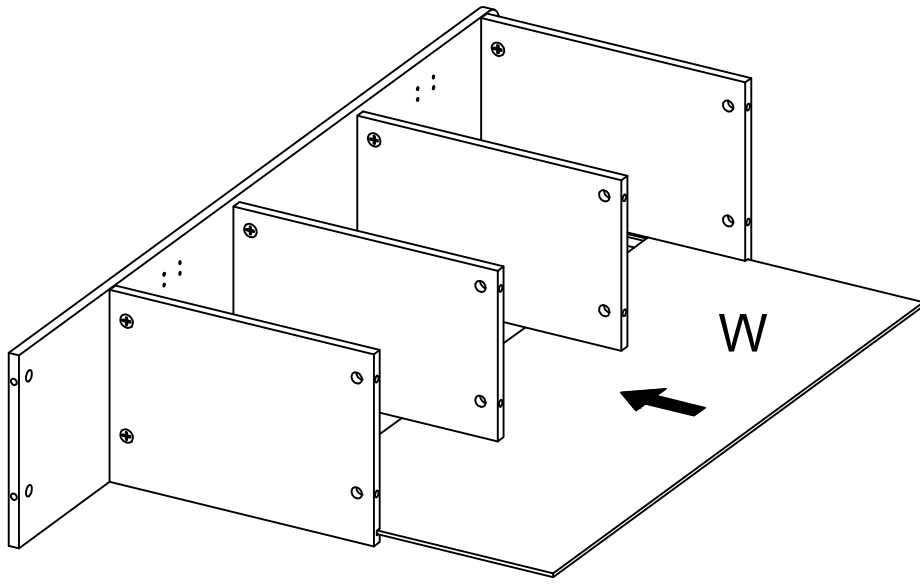

STEP 28

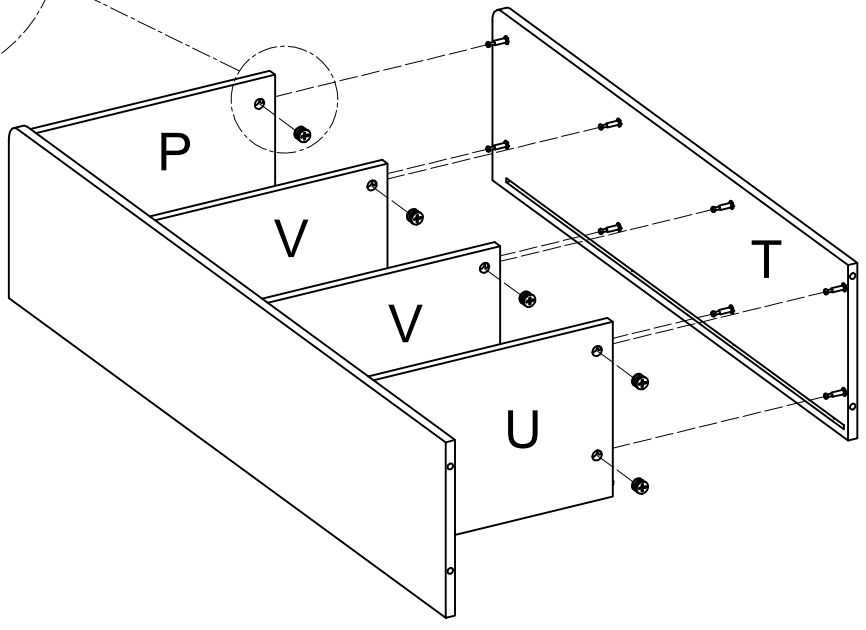
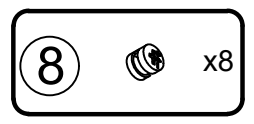
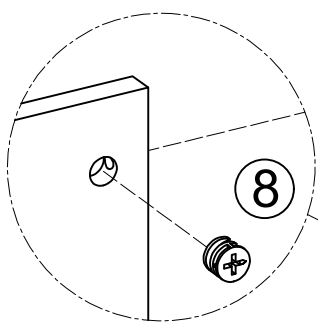

STEP 29

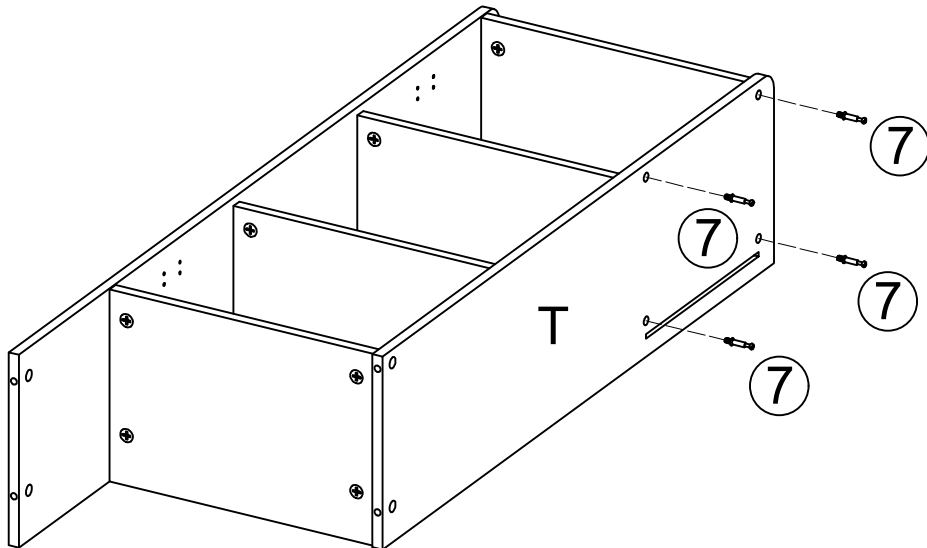
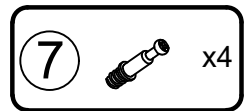

STEP 30

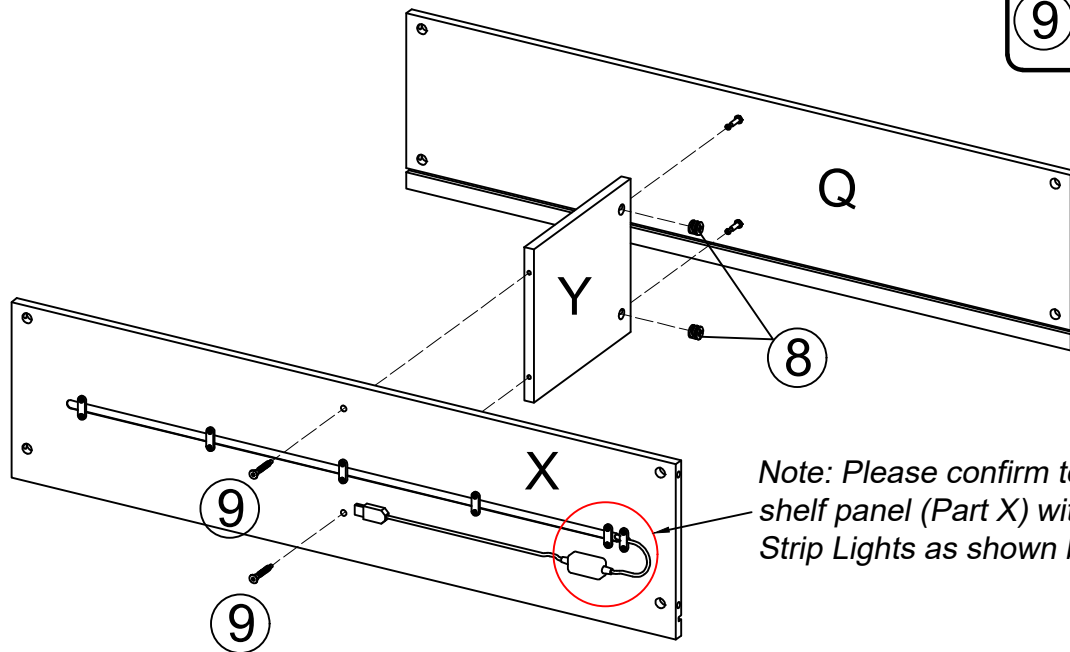
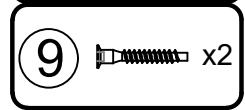
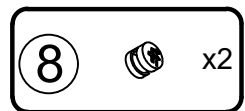

STEP 31

8  x4

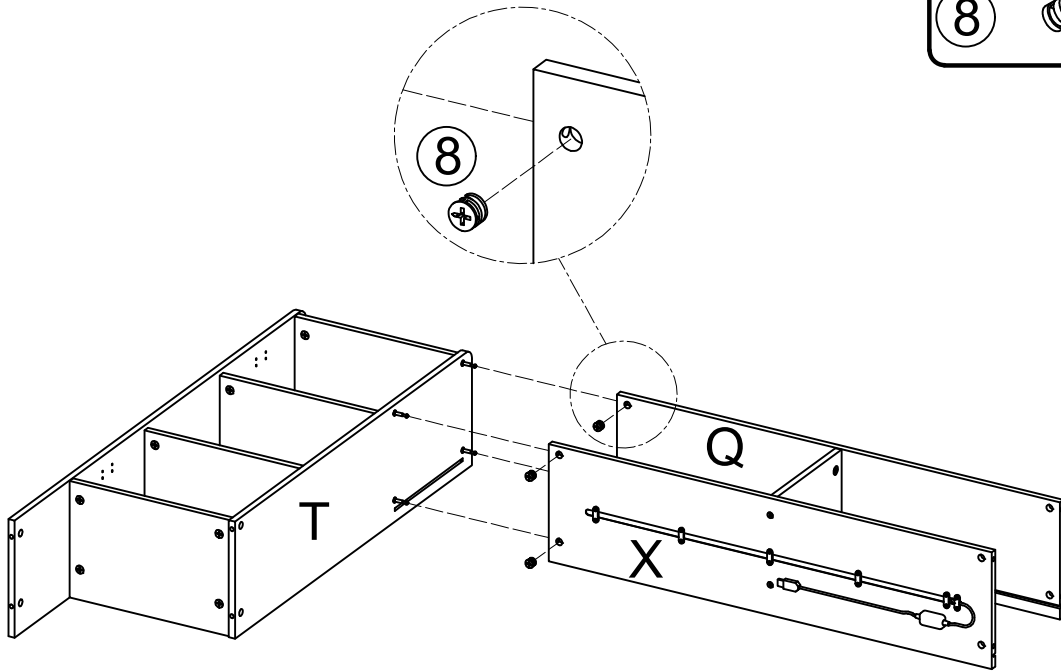

STEP 32

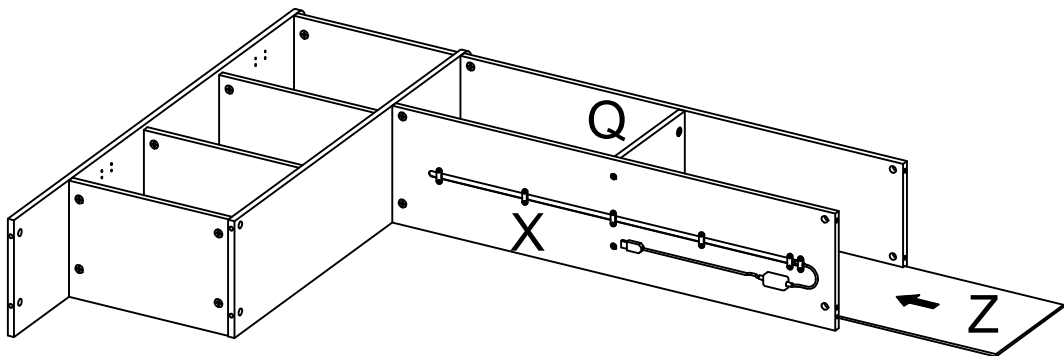

STEP 33

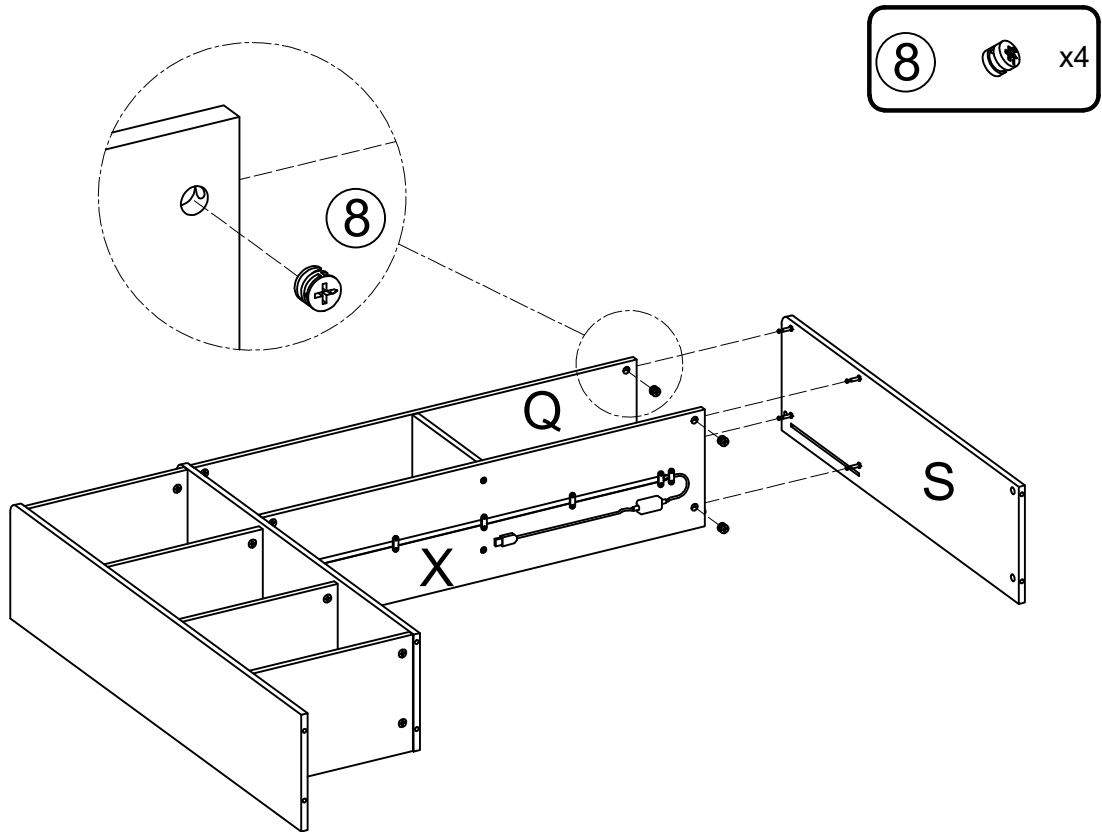

STEP 34

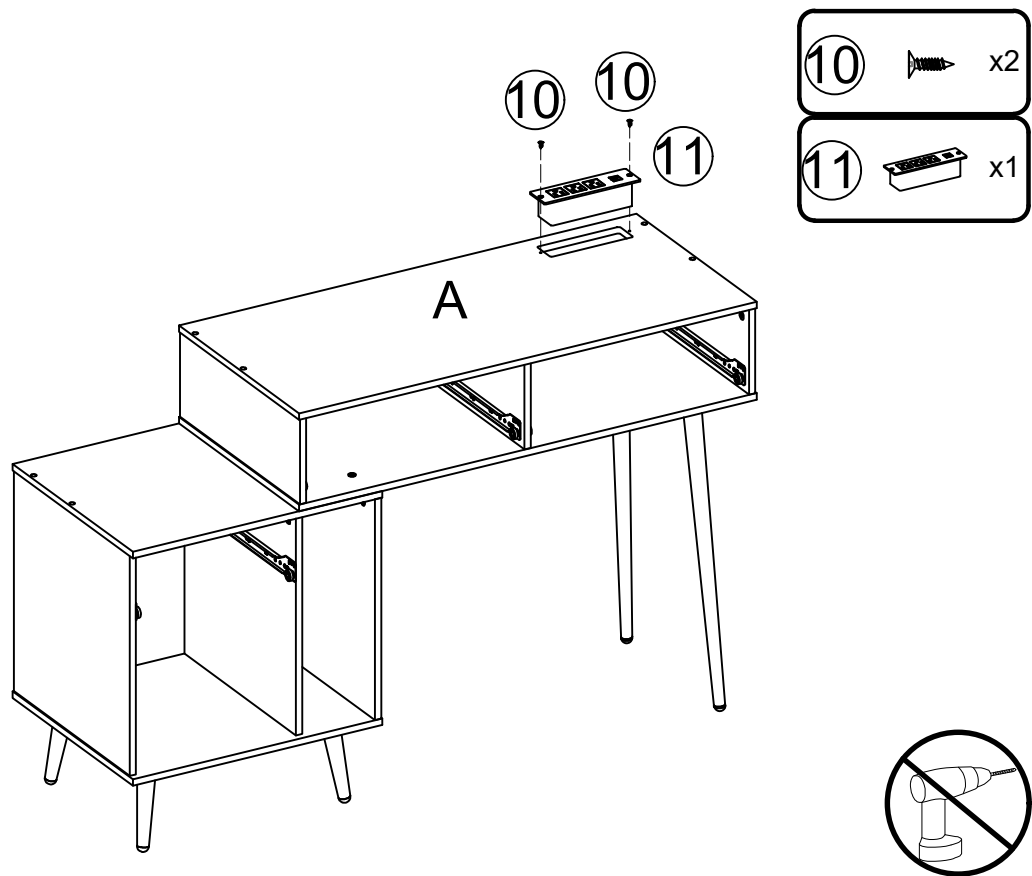

STEP 35

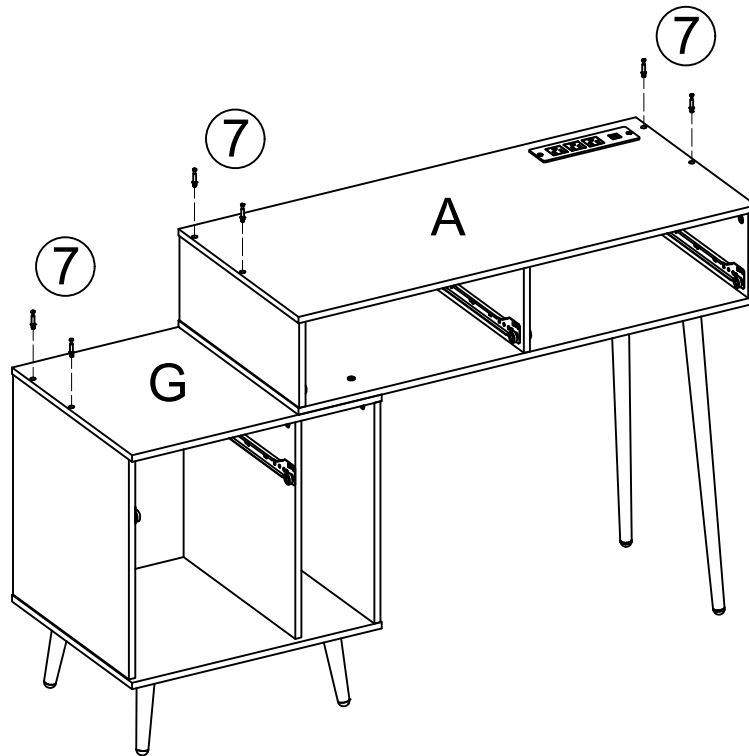

STEP 36

We recommend 2 person to assemble.

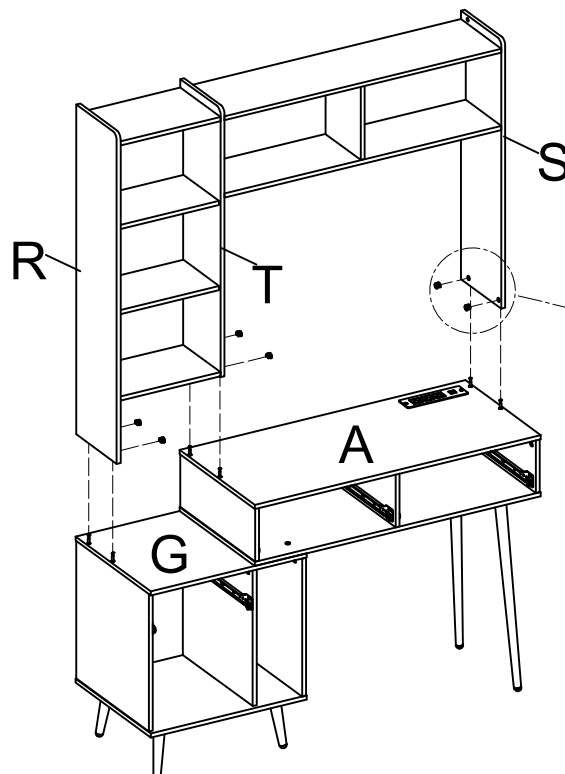

STEP 37

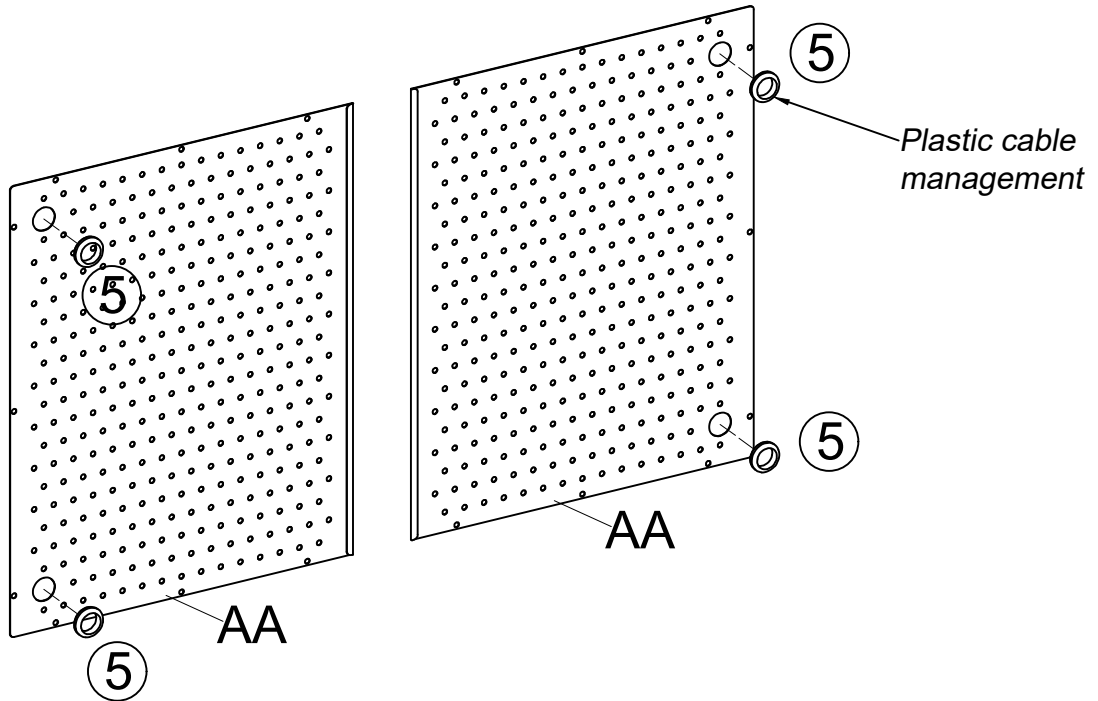
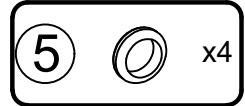

STEP 38

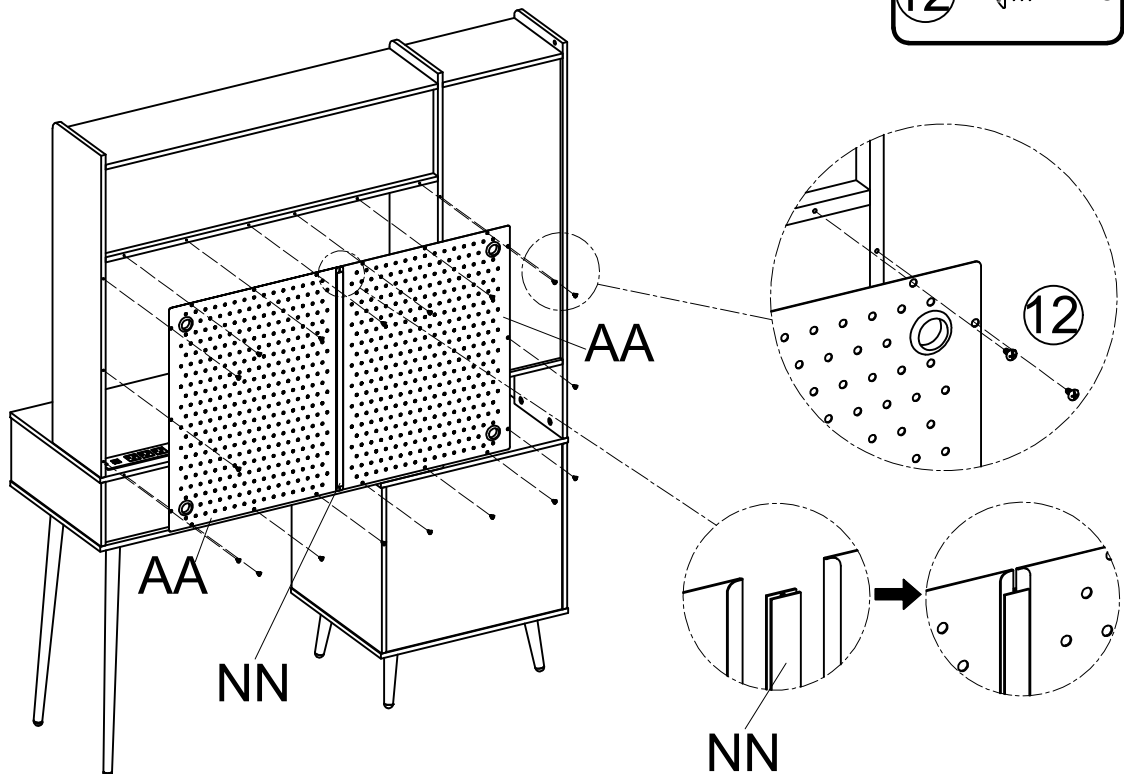
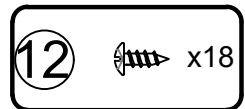

STEP 39

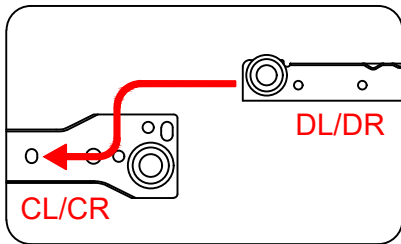

Please put the wheels align with the slots as the instruction shows, then slide into them

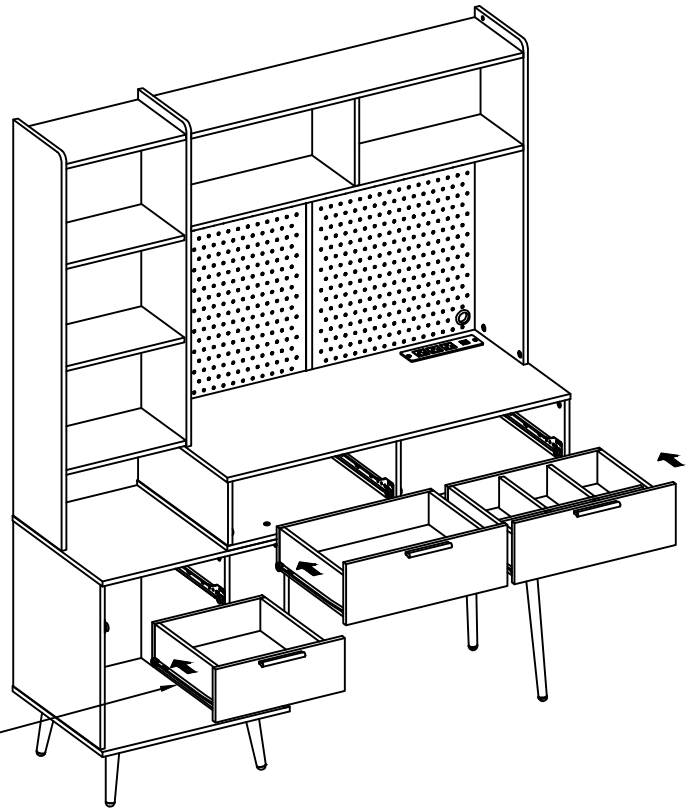

STEP 40

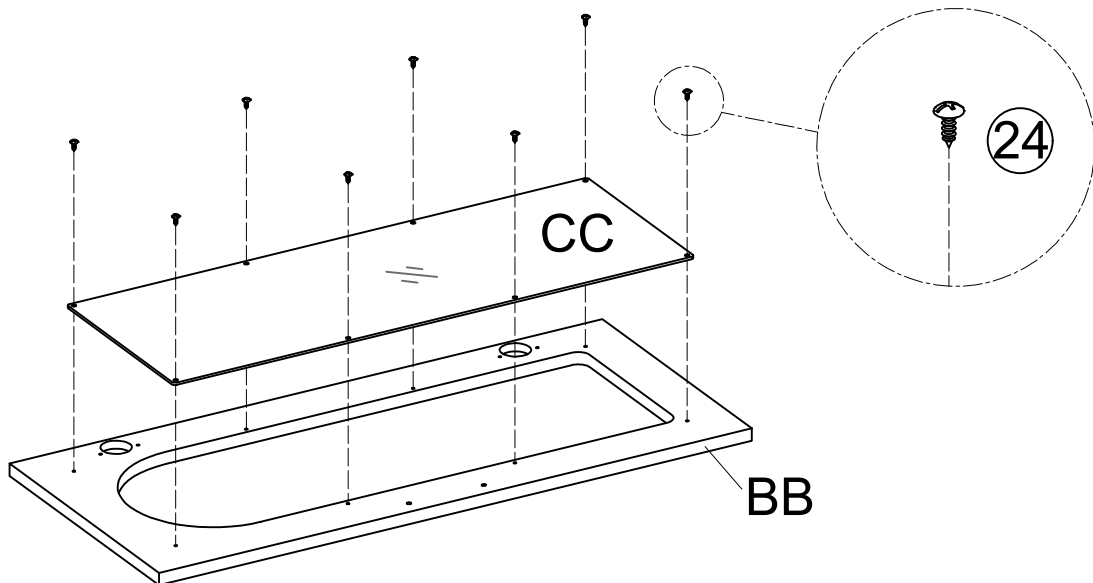
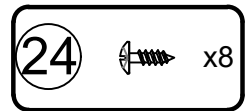

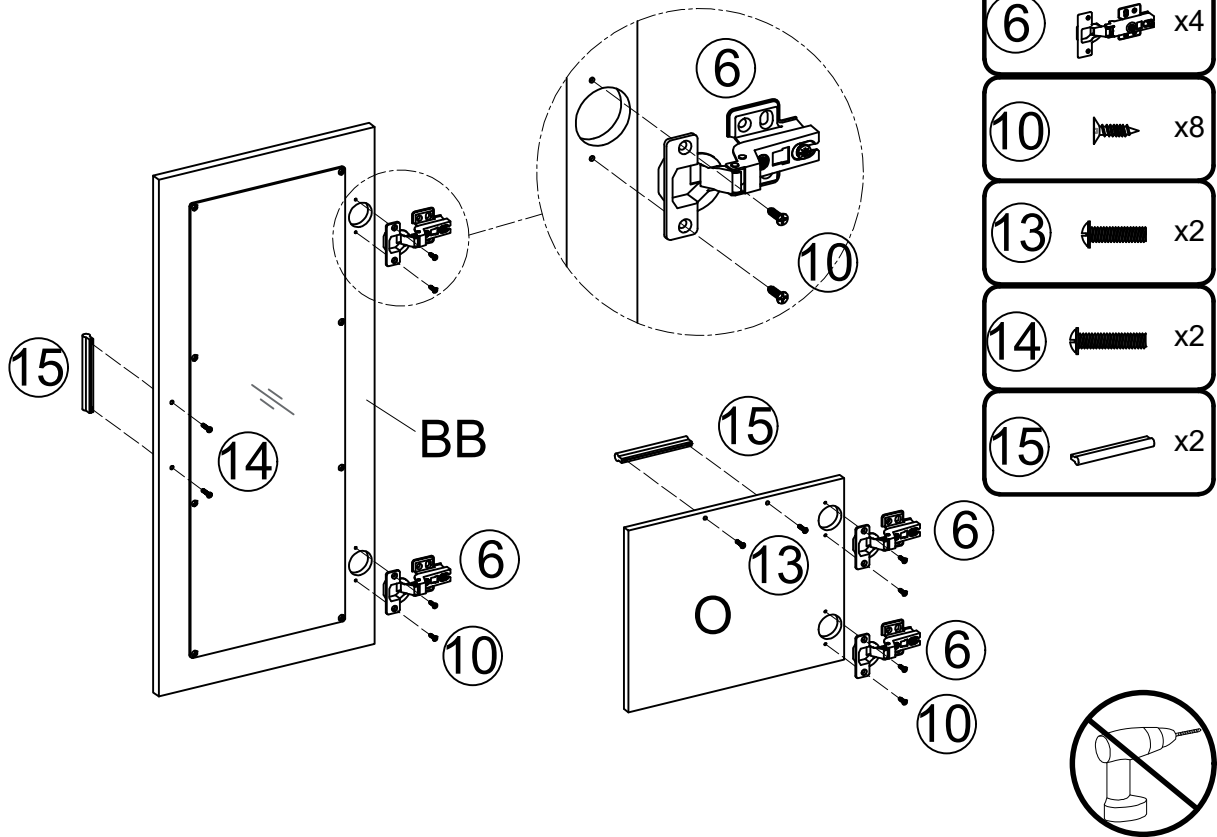

STEP 41

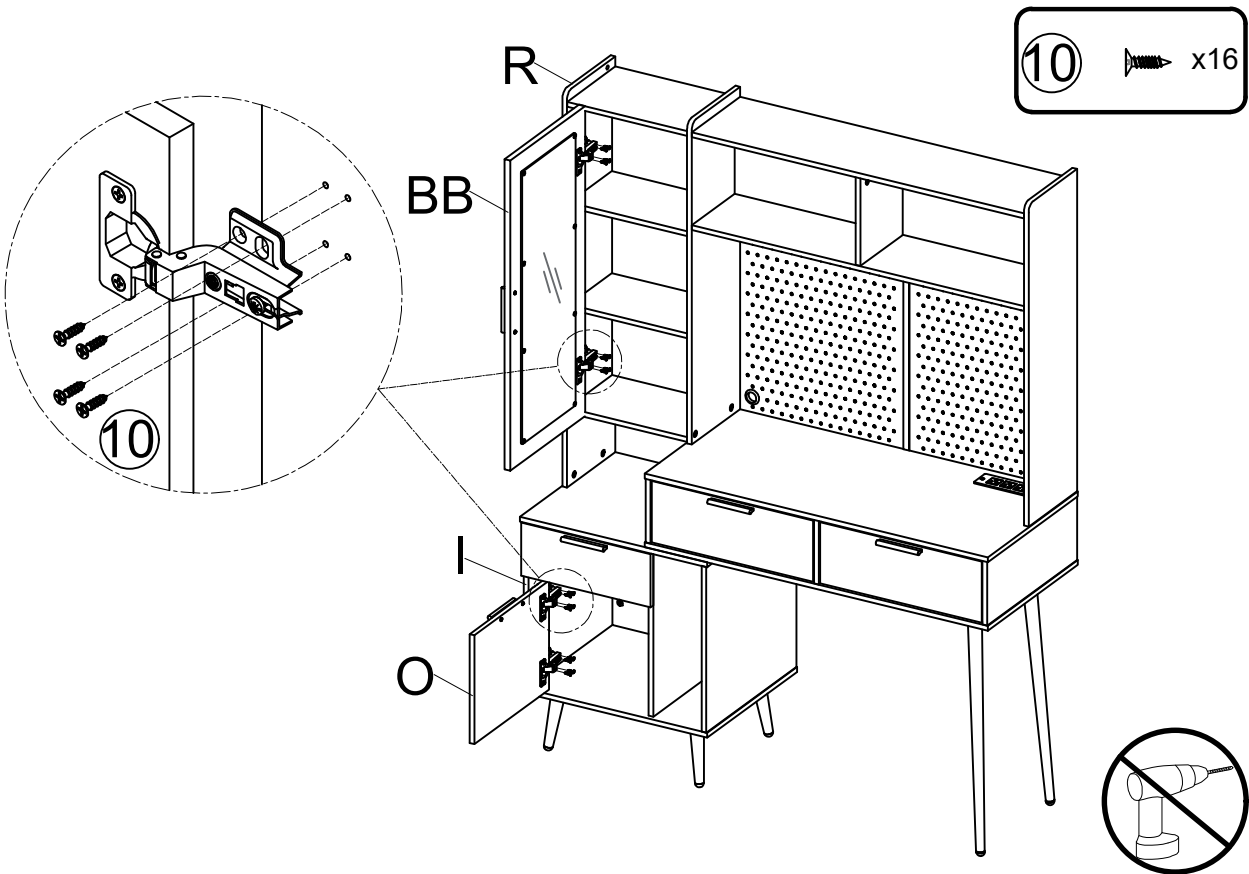

STEP 42



STEP 43

- 10  x42
- 21  x42

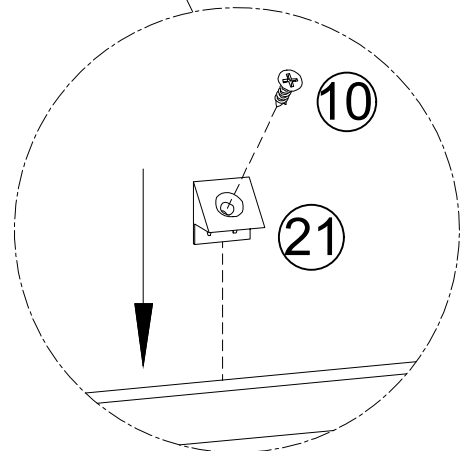
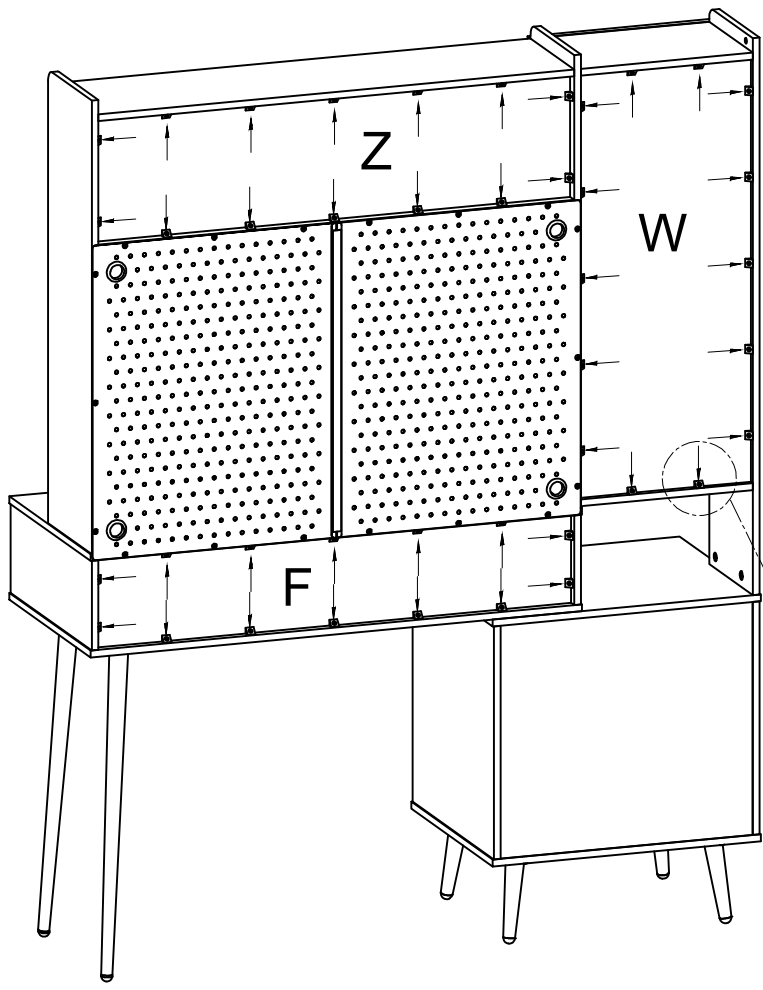

STEP 44

TIPPING RESTRAINT HARDWARE

Note: We have included two Tipping Restraint Hardware set for this Unit. When properly installed, this restraint can provide protection against the unexpected tipping of the Unit due to small tremors, bumps or climbing. We strongly recommend mounting this hardware to a wall stud and your Unit.

Note: You must install the Tipping Restraint Hardware with the unit in use to prevent any accidents or damage to the unit.

