

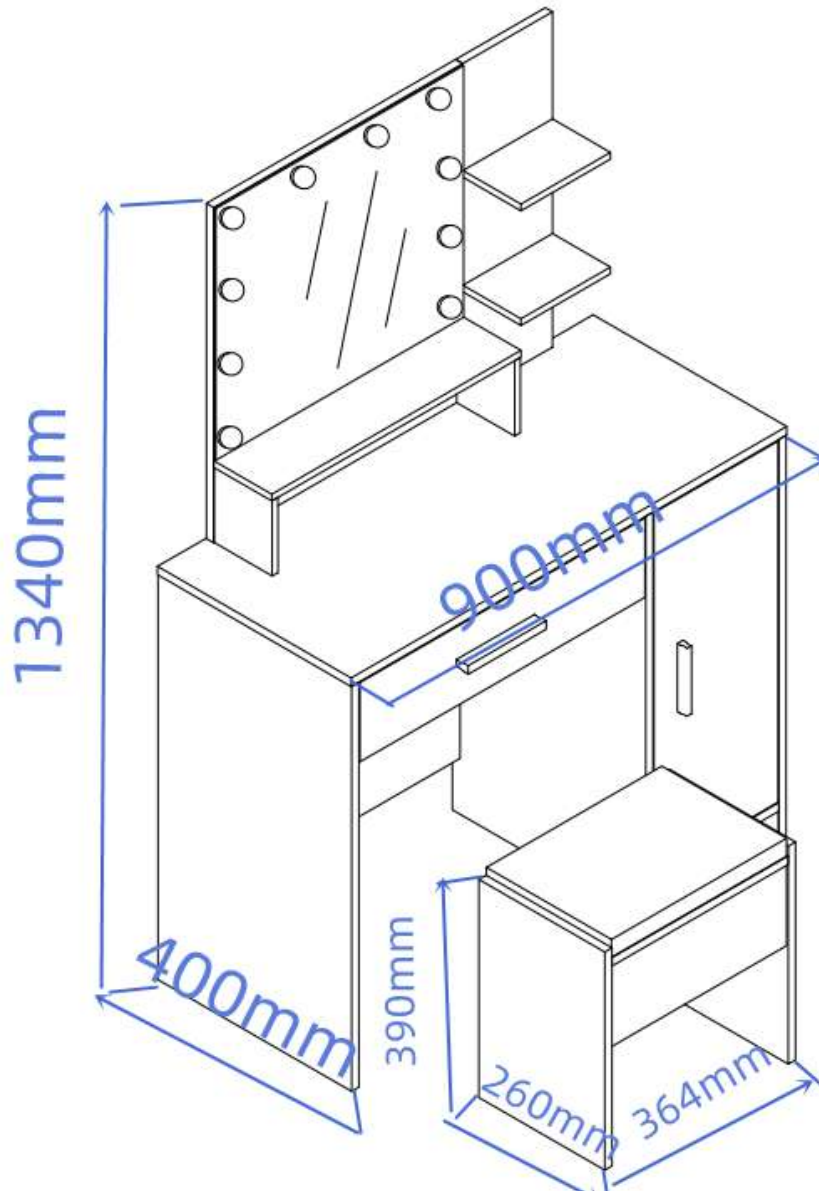

Dressing Table

Assembly Instructions – Please keep for future reference



Dimensions	No. people	Assembly Time	OW #
Width: 90 cm Depth: 40cm Height: 134cm		50 mins (approx.)	DRSSOPBLK

thank you

For purchasing this
GPM Limited
product

Important – Please read these instructions fully before starting assembly

Safety and Care Advice

Important – Please read these instructions fully before starting assembly

- Check you have all the components and tools listed on pages 4 and 5.
- Remove all fittings from the plastic bags and separate them into their groups.
- Keep children and animals away from the work area, small parts could choke if swallowed.
- Make sure you have enough space to lay out the parts before starting.
- Do not stand or put weight on the product, this could cause damage.
- Assemble the item as close to its final position (in the same room) as possible.
- Assemble on a soft, level surface to avoid damaging the unit or your floor.
- We do not recommend the use of power drill/drivers for inserting screws, as this could damage the unit. Only use hand screwdrivers.
- Dispose of all packaging carefully and responsibly.



Care and Maintenance

- Only clean using a damp cloth and mild detergent, do not use bleach or abrasive cleaners.
- From time to time check that there are no loose screws on this unit.
- This product should not be discarded with household waste. Take to your local authority waste disposal centre.









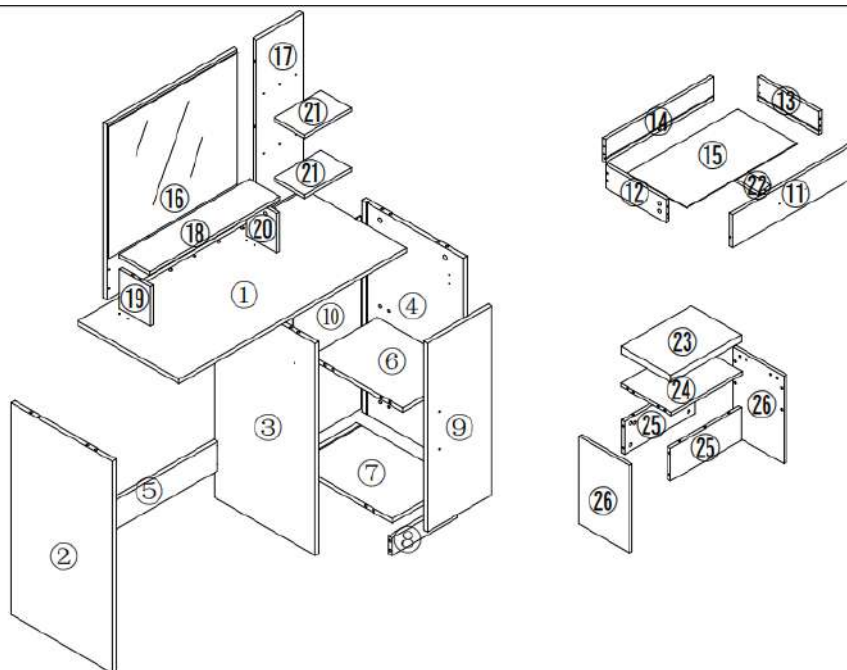

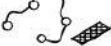











If kept outside please ensure in the winter months that the product is correctly covered or put away into a dry environment to prevent corrosion, weathering or damage.

If your product is not designed to be outside, we recommend that it is always kept indoors in a dry environment.

If you are unhappy with the product and wish to return it, please follow the retailer's returns procedure.

Exploded View



U  8PCS	V  1PCS	W  1PCS										
K  4PCS	L 4*18  4PCS	M 300mm  1PCS	N 300mm  1PCS	O 300mm  1PCS	P 300mm  1PCS	Q 128mm  2PCS	R  1PCS	S  S1 1PCS	T  2PCS			
A  49PCS	B  49PCS	C 8*40  23PCS	D 6*30  4PCS	E 8*60  3PCS	F 3*12  8PCS	G 3.5*14  32PCS	H 3.5*30  15PCS	I 3.5*35  4PCS	J  4PCS			

Components - Panels

Please check that you have all the components listed below before constructing your item.













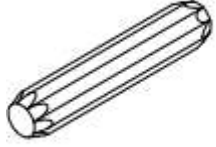
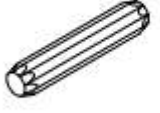

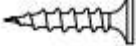
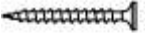

Part No	Description	Qty	Size (mm)	Thickness (mm)
1	TABLE TOP PANEL	1	900*400	15
2	LEFT SIDE PANEL	1	725*400	15
3	VERTICAL PANEL	1	725*40	15
4	RIGHT SIDE PANEL	1	725*40	15
5	BACK CONNECTOR PANEL	1	593*100	15
6	SHELF PANEL	1	260*360	15
7	BOTTOM PANEL	1	260*400	15
8	KICKER PANEL	1	260*60	15
9	DOOR	1	646*256	15
10	BACK PANEL	1	270*660	3
11	DRAWER FACE	1	589*142	15
12	LEFT DRAWER PANEL	1	300*100	15
13	RIGHT DRAWER PANEL	1	300*100	15
14	DRAWER STOPPER	1	537*100	15
15	DRAWER BOTTOM PANEL	1	547*294	3
16	VERTICAL PANEL	1	515*600	15
17	VERTICAL PANEL	1	185*600	15
18	SHELF	1	515*120	15
19	VERTICAL PANEL	1	135*120	15
20	VERTICAL PANEL	1	135*120	15
21	SHELF	2	185*120	15
22	DRAWER BOTTOM SUPPORT	1	284*60	15
23	PU CUSHION	1	362*258	32
24	STOOL FACE PANEL	1	364*260	15
25	STOOL SIDE PANEL	2	390*260	15
26	STOOL CONNECTOR	2	364*146	15

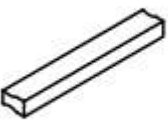
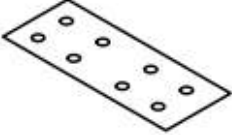

Important – Please read these instructions fully before starting assembly

Components - Fixings

Please check that you have all the components listed below before constructing your item.

Note: The quantities below are the correct amount to complete the assembly. In some cases more fittings may be supplied than are required.

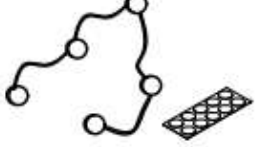
(A)	 49PCS	(B)	 49PCS	(C)	 8*40 23PCS	(D)	 6*30 4PCS
(E)	 8*60 3PCS	(F)	 3*12 8PCS	(G)	 3.5*14 32PCS	(H)	 3.5*30 15PCS
(I)	 3.5*35 4PCS	(J)	 4PCS	(K)	 4PCS	(L)	 4*18 4PCS
(M)	 300mm 1PCS	(N)	 300mm 1PCS	(O)	 300mm 1PCS	(P)	 300mm 1PCS
(Q)	 128mm 2PCS	(R)	 1PCS	(S)	 S1  S2 1PCS	(T)	 2PCS

(U)	 <p>8PCS</p>	 <p>1PCS</p>	 <p>1PCS</p>	(X)
-----	---	---	--	-----

Tools Required

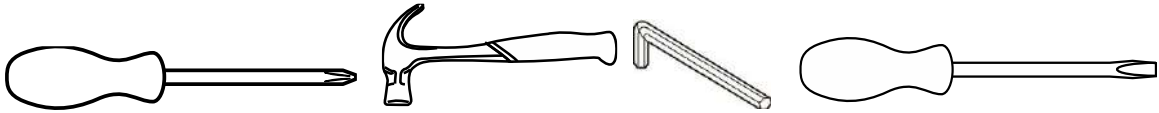

Ruler – Use this to measure your screws (mm)

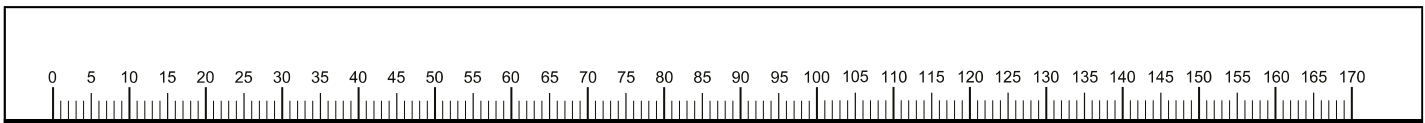

Important – Please read these instructions fully before starting assembly

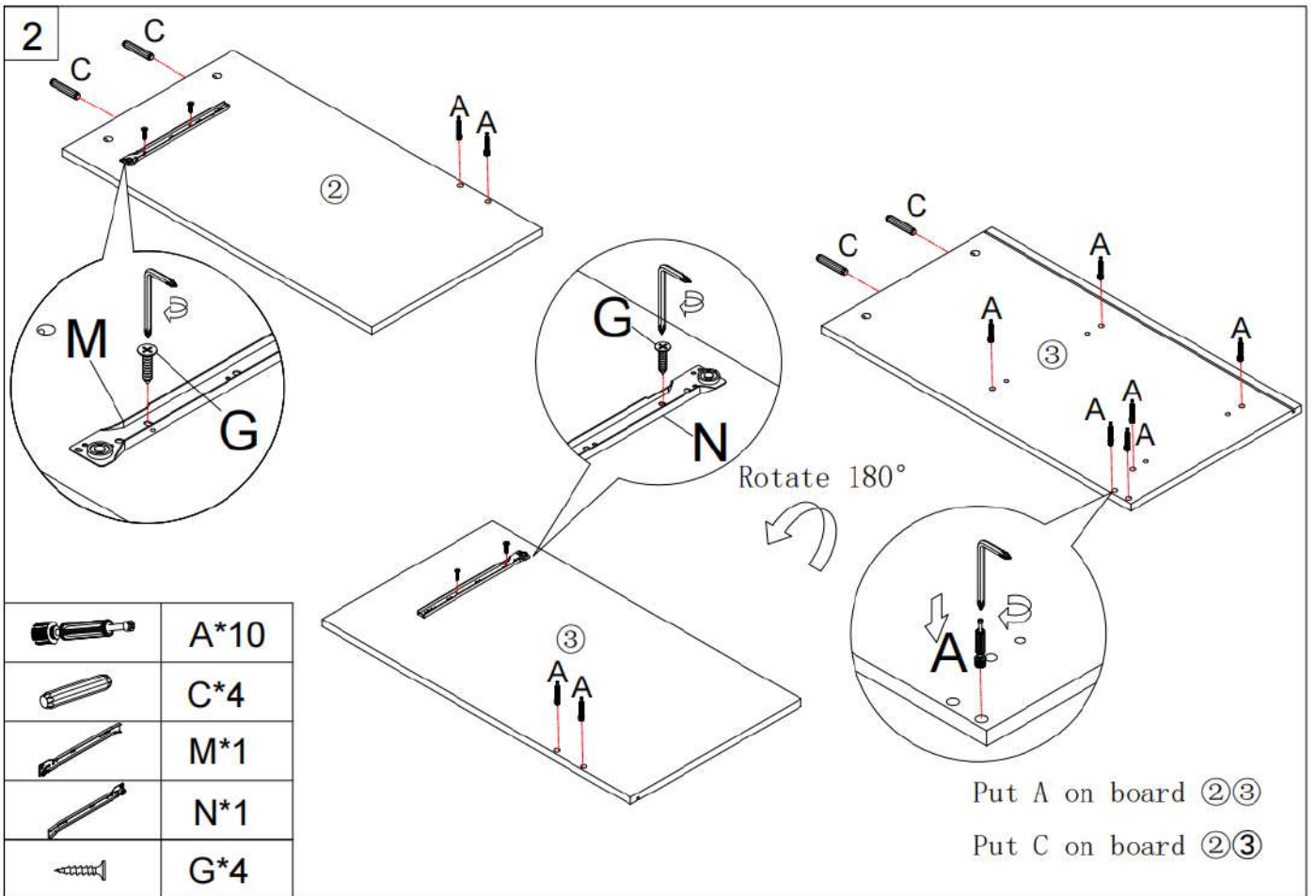
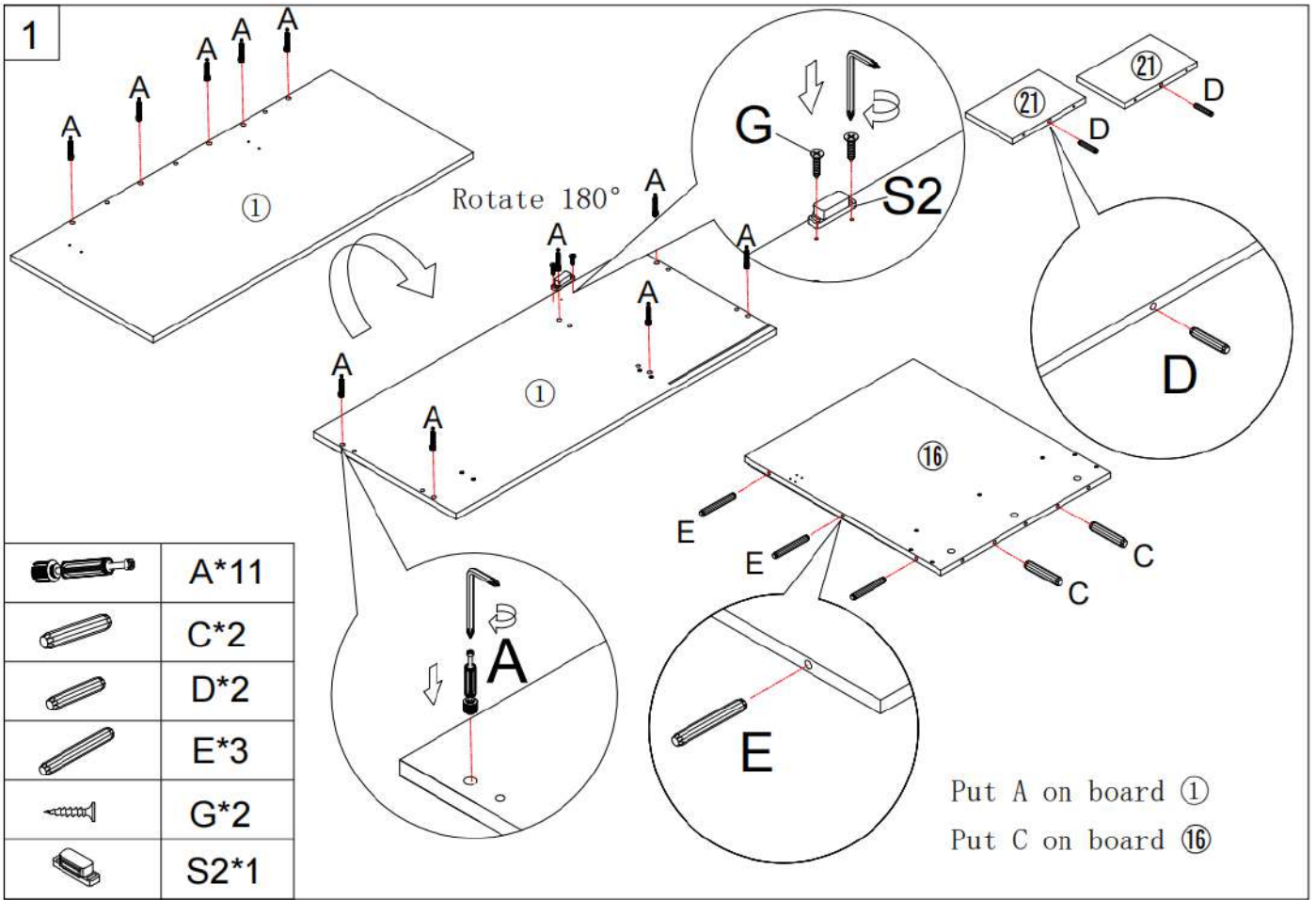

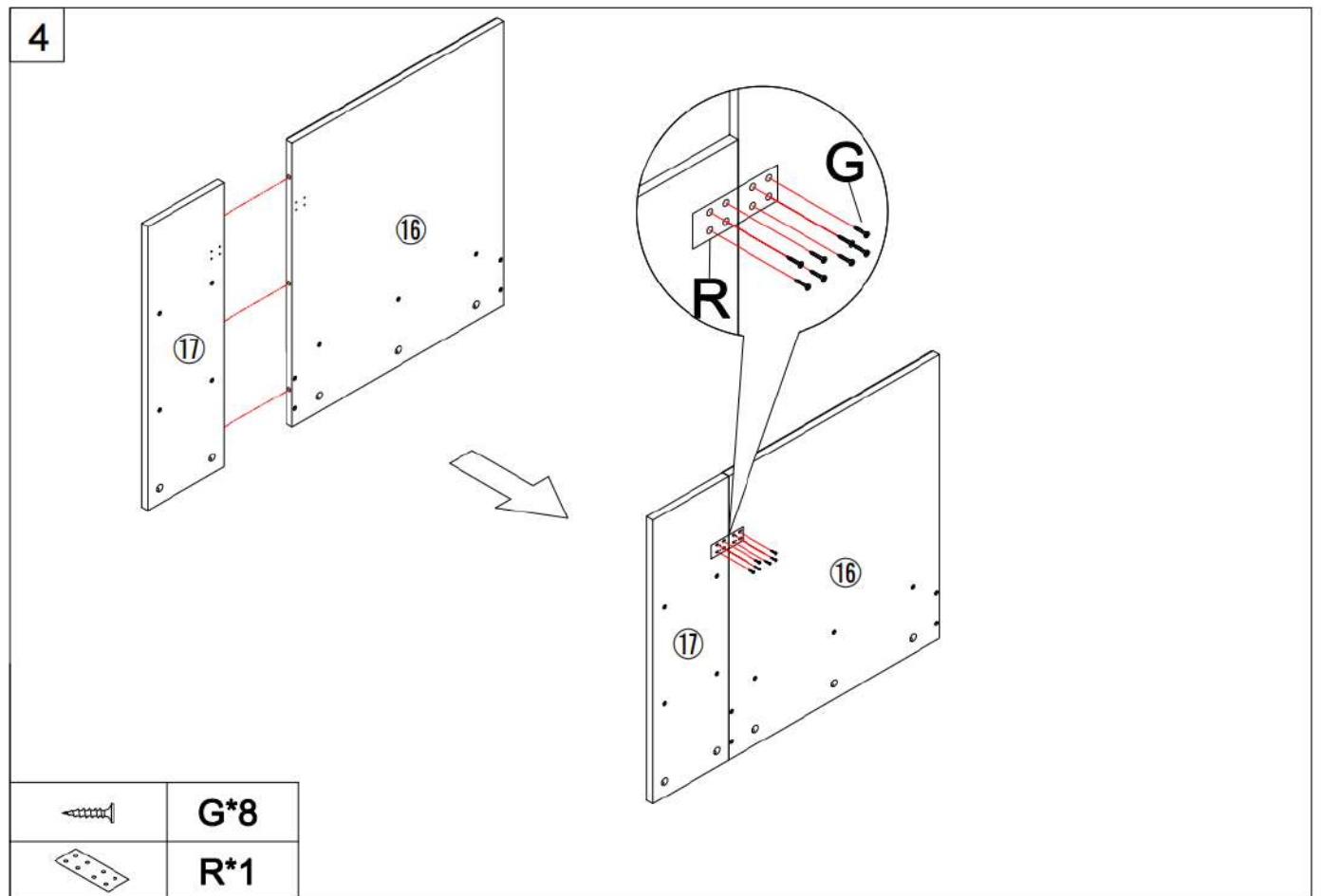
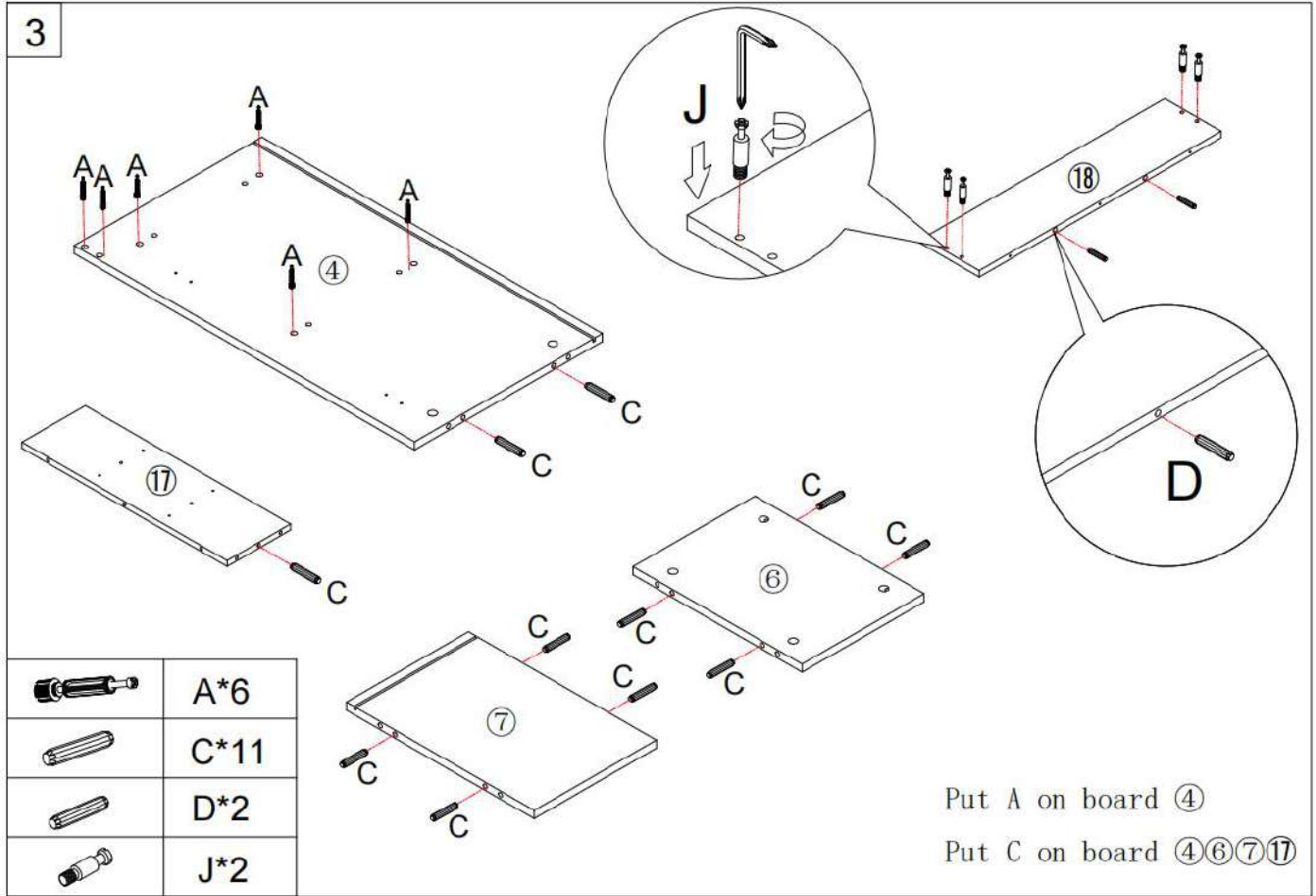

5

Make sure the arrow on the screw align to the hole on the side

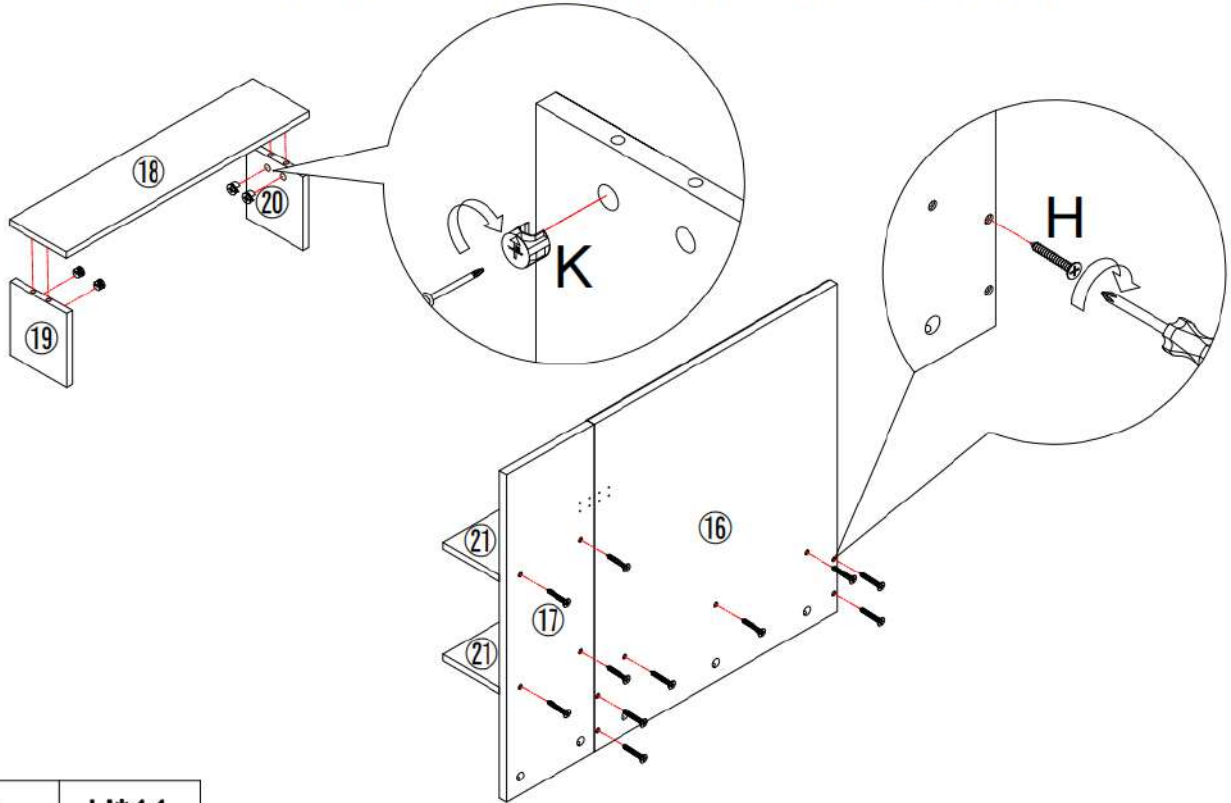



	H*11
	K*4

Put H to pass through board NO. 16 & 17. Then to fix board NO. 18, 19, 20 & 21.

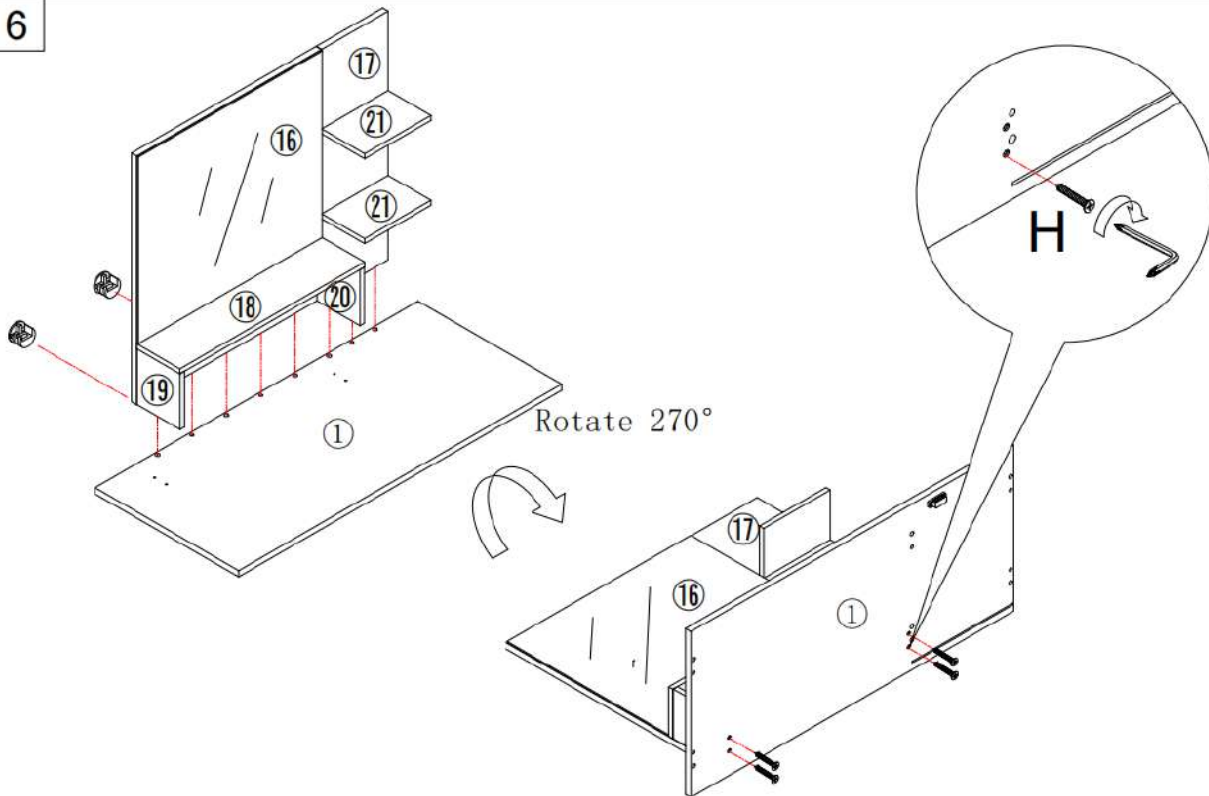
6



	B*5
	H*4

Put H to pass through board NO.1. Then to fix board NO.19&20.

Put B on board 16 & 17

7

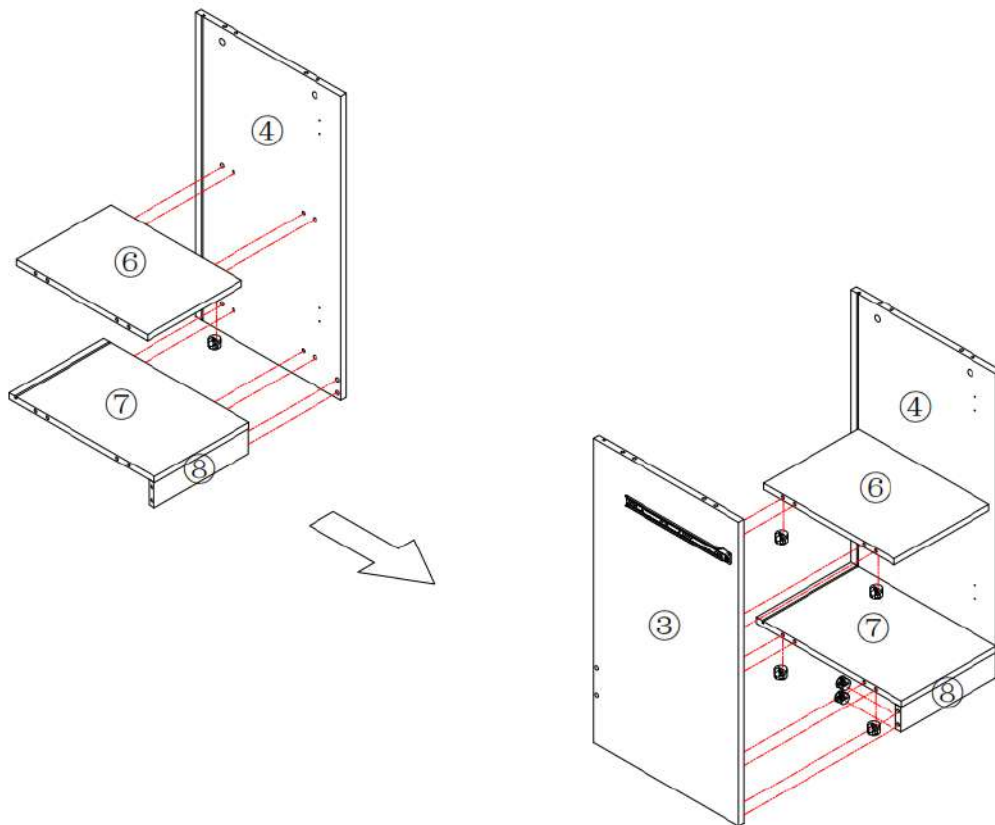

Put B on board ⑥⑦⑧



B*12

8

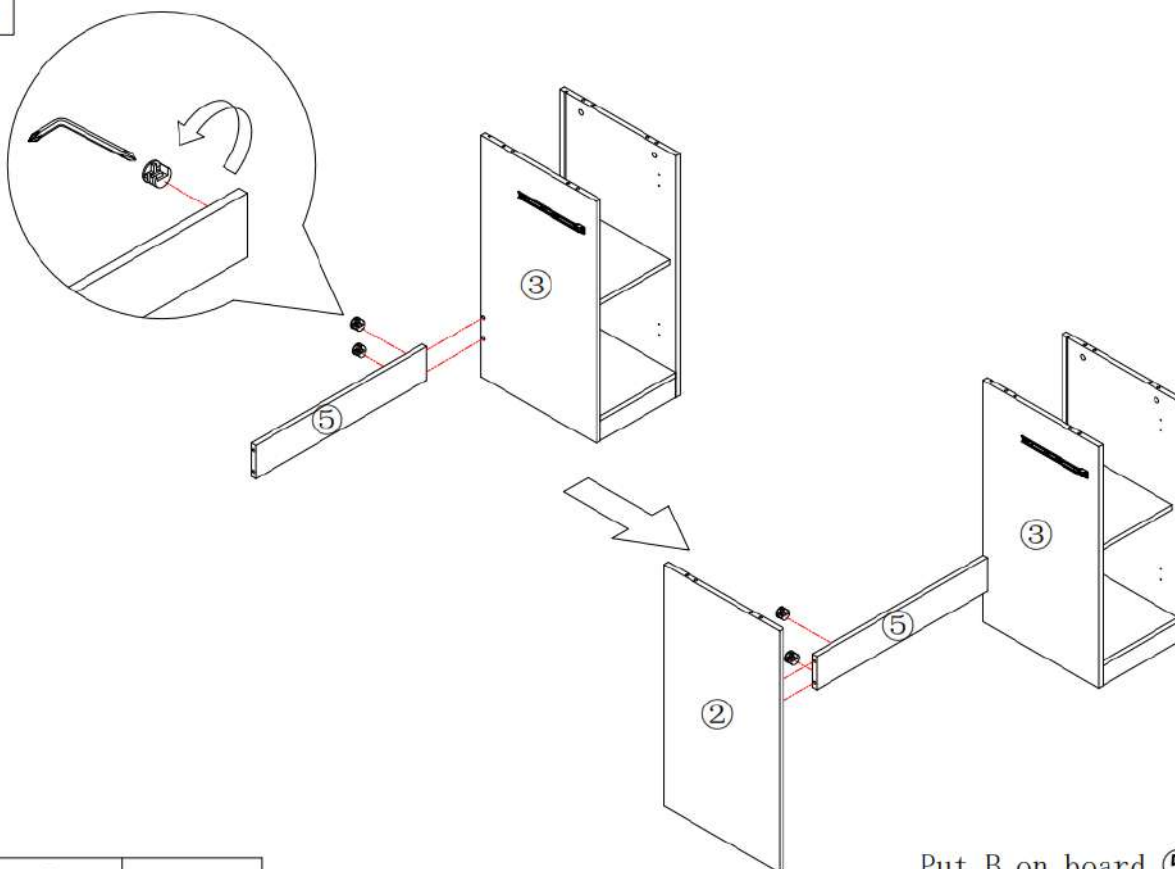

Put B on board ⑤



B*4

9

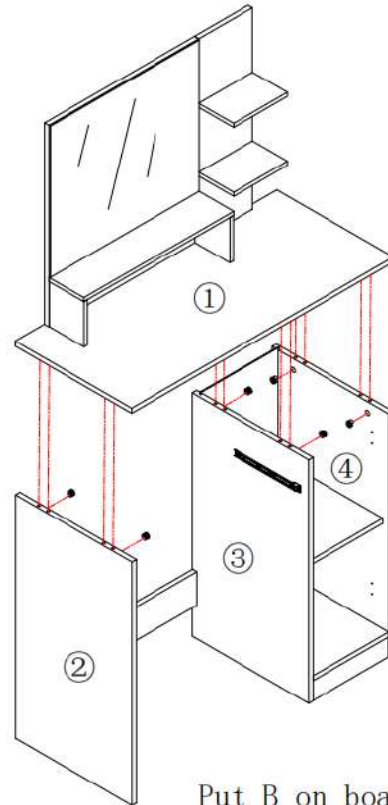
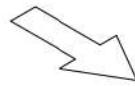
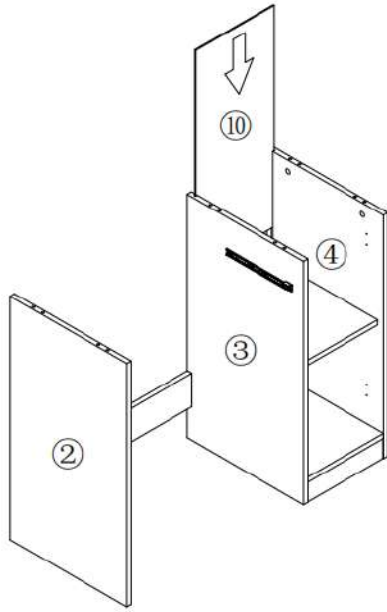







Put B on board ②③④

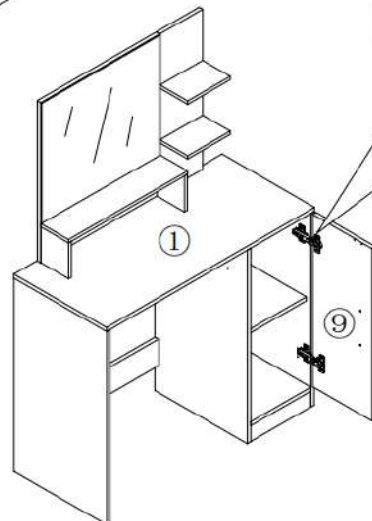
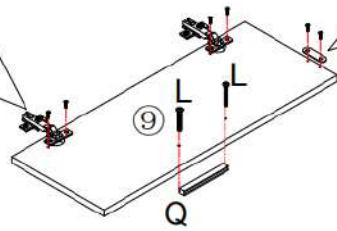
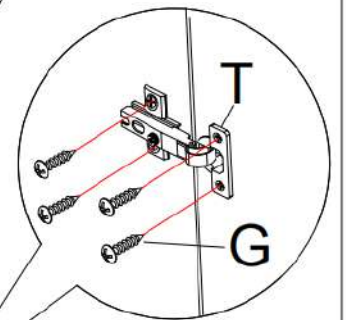
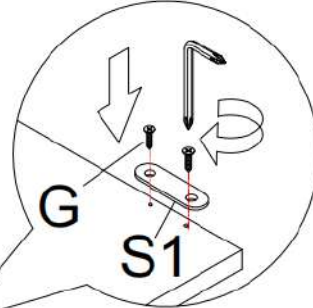
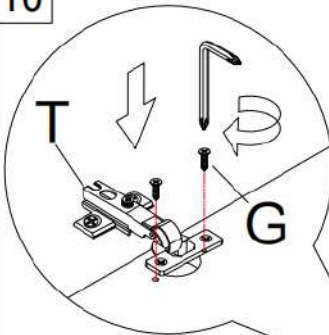

B*6

10



	G*14
	L*2
	Q*1
	S1*1
	T*2

11

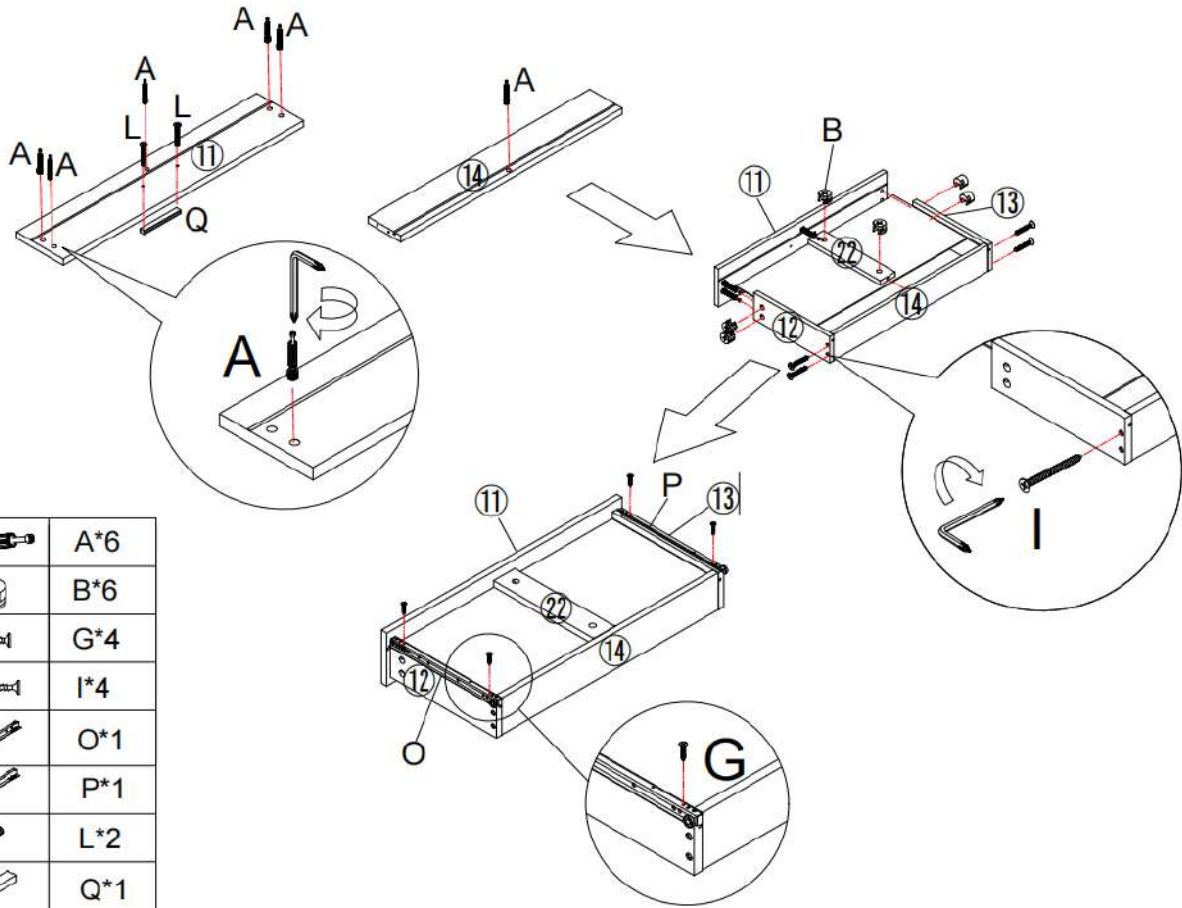

12

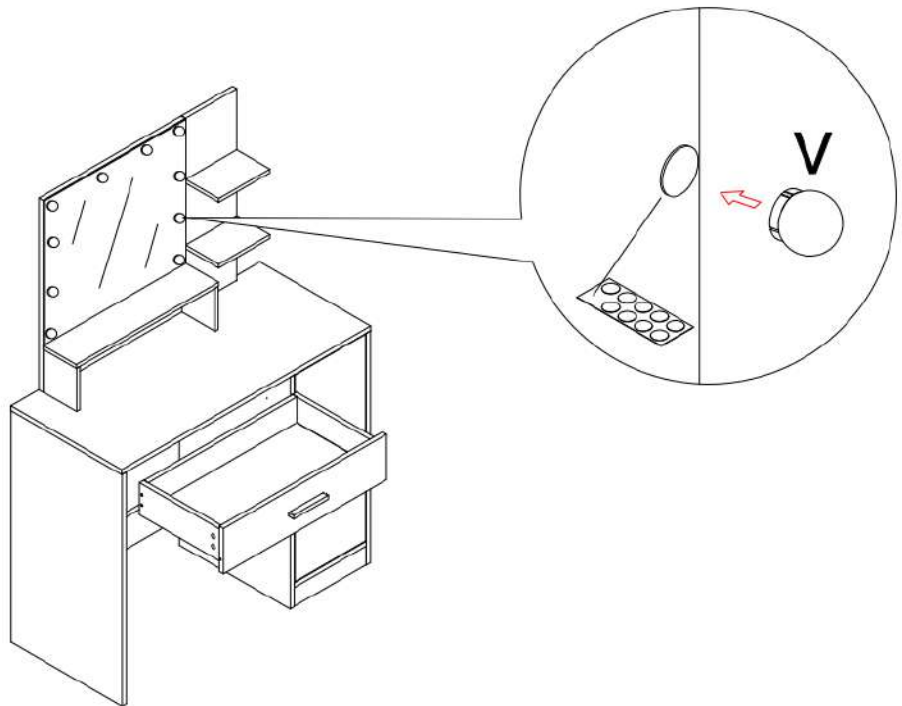

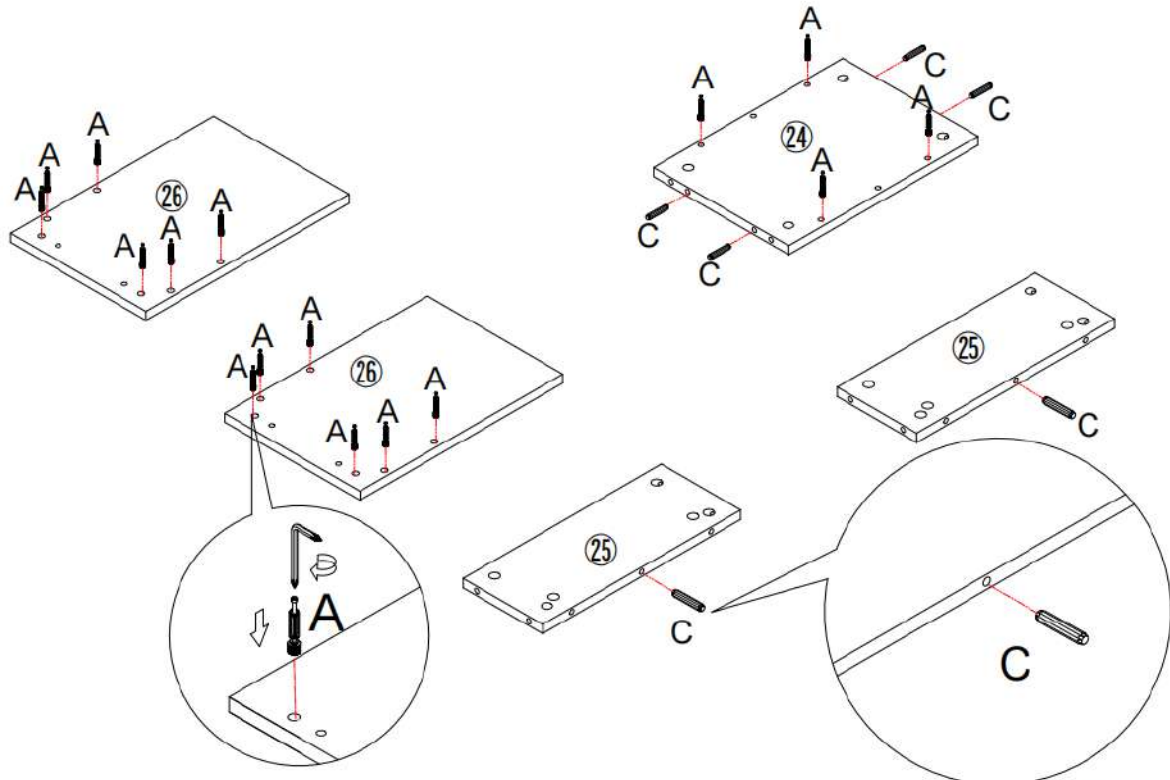

	V*1
--	-----

13



Put A on board ②4②6
Put C on board ②4②5

	A*16
	C*6

14

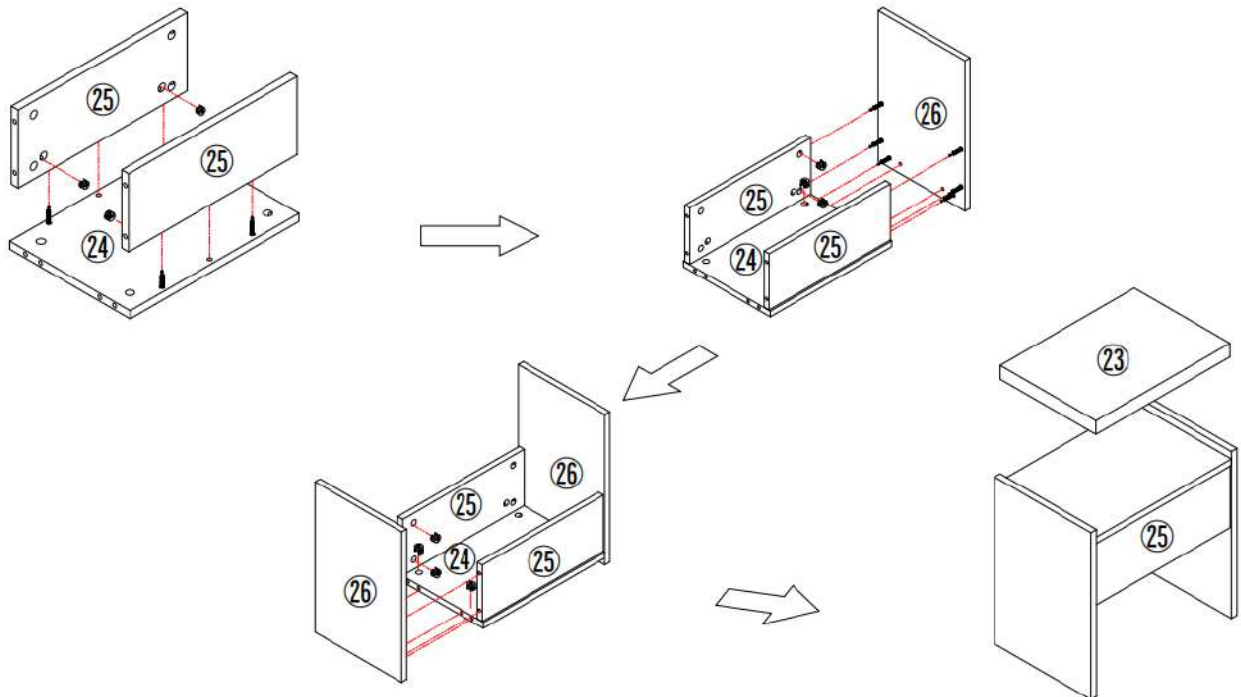



Put B on board ②4②5

	B*16
---	------

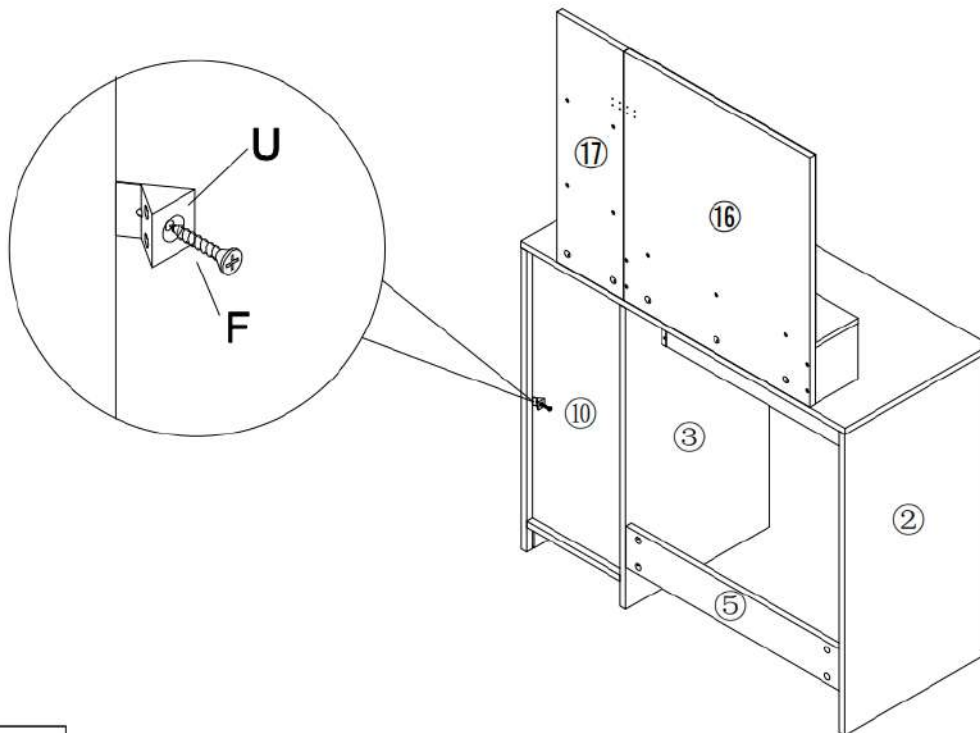
15



	F*8
	U*8

16

