

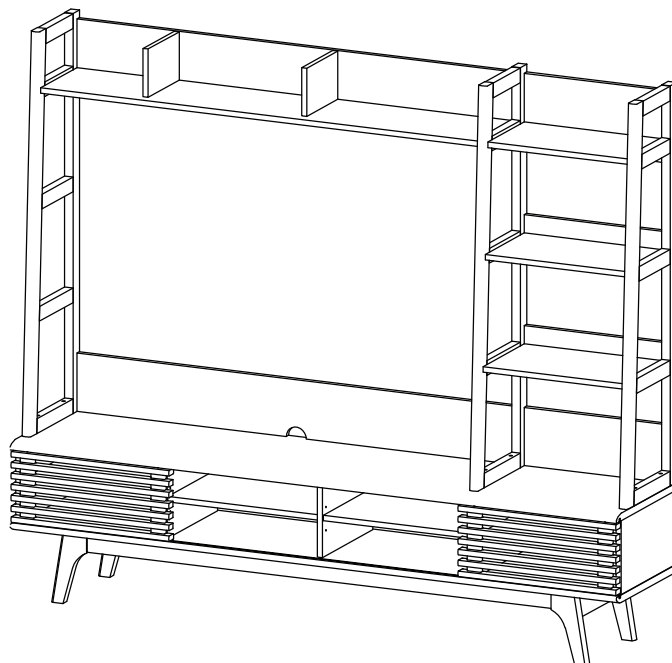

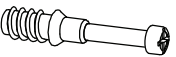







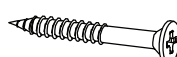



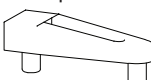
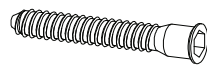

Before you start, here are some helpful advice:

1. We suggest you spend a short time reading through this leaflet and then follow the simple step-by-step instructions.
2. Owing to the size and weight of the TV Stand, we recommend that it is assembled by two adults, on a carpeted or padded area, in the room that it is intended for. Approximate assembly time: 120 minutes.
3. Please do not use any tools other than those provided or recommended in these instructions.
4. Please do not throw away any of the packaging or instructions until you have checked all the components and hardware and the furniture is fully assembled.
5. Assemble all components loosely until advised to tighten. Depending on use, it may be necessary to tighten the components from time to time, so please save the tools that have been provided.
6. Please keep all pieces out of reach of children.

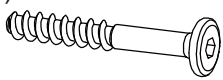
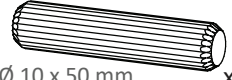

**Hardware :**

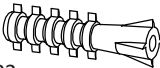
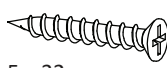
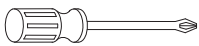
A) Cambolt/Metal  ∅ 6 x 35 mm x 49	B) CamLock/Metal  ∅ 15 mm x 49	C) Dowel/Wood  ∅ 8 x 30 mm x 86	D) Screw/Metal  M 12 x 35 mm x 4	E) Grommet Hole Edge cover  x 1
F) Shelf Pin/Metal  ∅ 5 x 15 mm x 16	G) Screw/Metal  M 3.5 x 15.5 mm x 16	H) Wedge/Plastic  9 x 14 x 10 mm x 12	I) Floor Protector/Sponge/Felt  25 x 25 x 2 mm x 4	J) Screw Cup/Plastic  ∅ 15 mm x 7
K) Pin Sliding Top/Plastic  ∅ 8 x 19 mm x 4	L) Pin Sliding Bottom/Plastic  ∅ 8 x 16 mm x 4	M) Stoper/Plastic  42 x 14 x 8 mm x 2	N) Screw/Metal  M 7 x 50 mm x 17	O) Hex/Allen Key/Metal  L 4 x 1
P) Anti-Deflection Bar/Metal  1200 mm x 1	Q) Buffer/Rubber  ∅ 8 mm x 1	R) Screw/Metal  M 6 x 12.5 mm x 14	S) Screw/Metal  M 6.4 x 53 mm x 6	T) Dowel/Wood  ∅ 10 x 50 mm x 6
U) Cable Ties/Plastic  x 2	V) Wall plug  5003 x 4	W) Screw/Metal  M 3.5 x 32 mm x 4	X) Screwdriver (Not Include)  x 1	

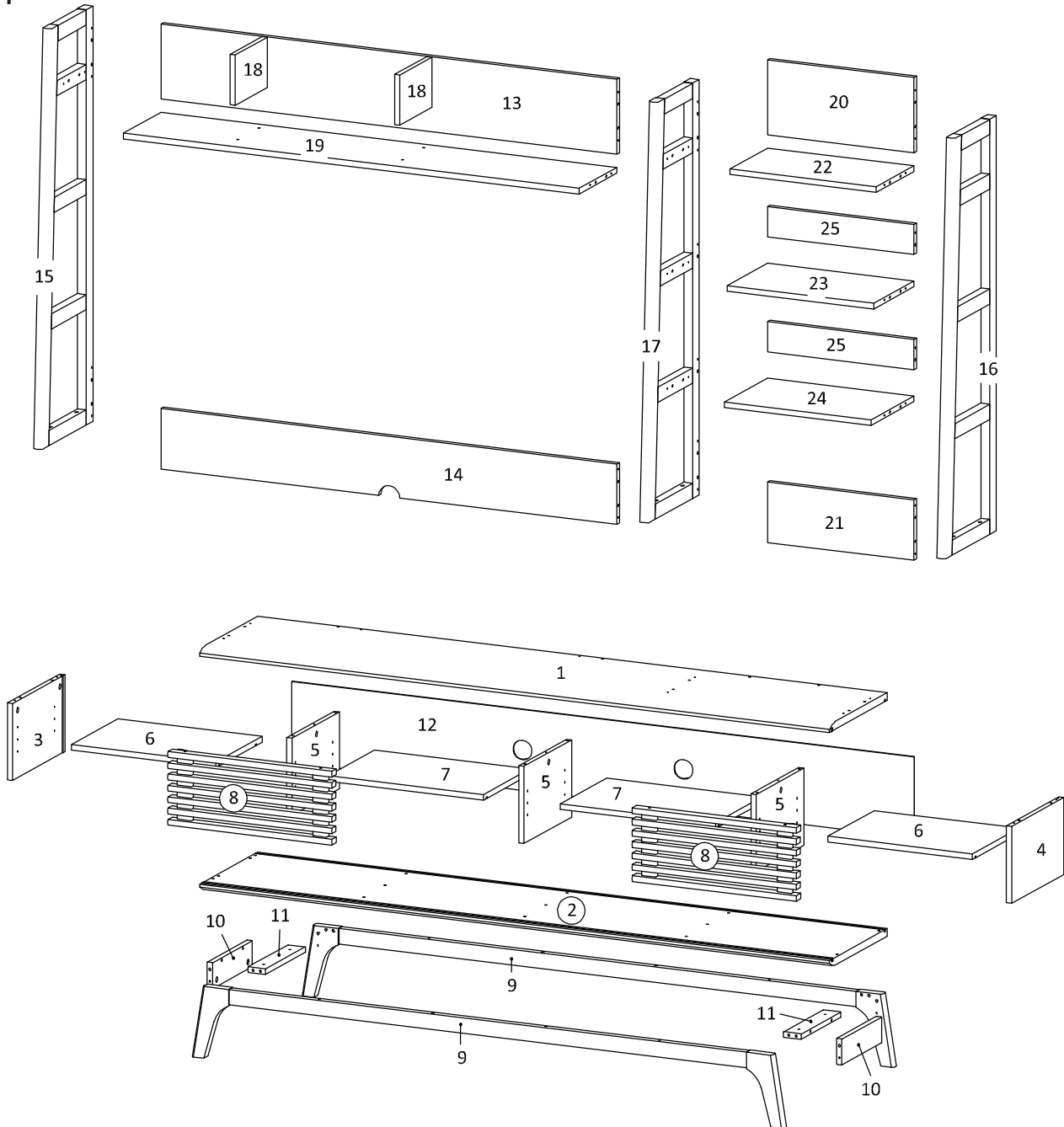

**Components:**

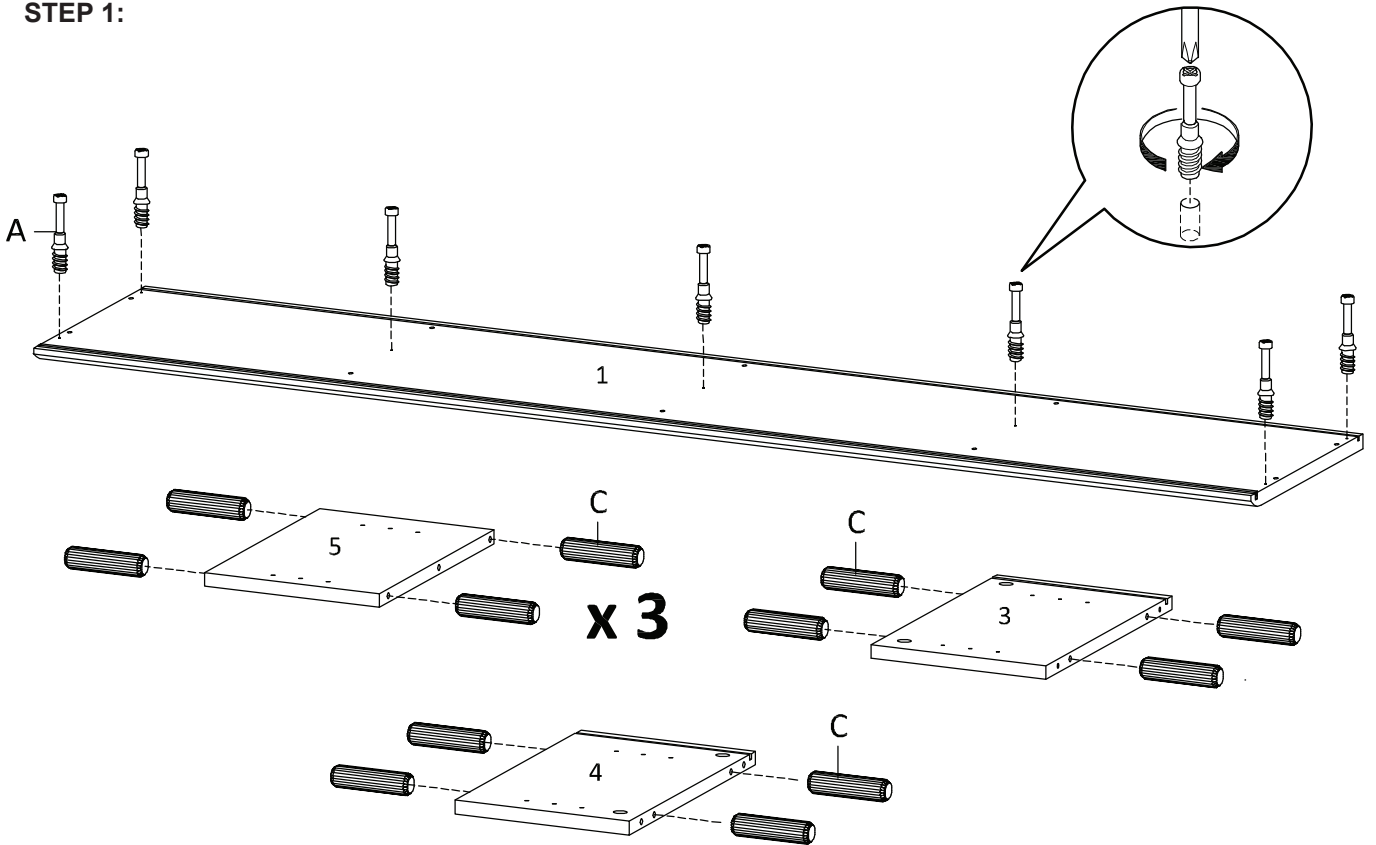

1	Top Board	x1	2	Bottom Board	x1	3	Side Board Left	x1	4	Side Board Right	x1
5	Center Board	x3	6	Adjustable Shelf 1	x2	7	Adjustable Shelf 2	x2	8	Frame Door	x2
9	Assembly leg	x2	10	Support Board 1	x2	11	Support Board 2	x2	12	Back Board	x1
13	Back Board 1 (Hutch)	x1	14	Back Board 2 (Hutch)	x1	15	Frame Left (Hutch)	x1	16	Frame Right (Hutch)	x1
17	Frame Middle (Hutch)	x1	18	Divider Board (Hutch)	x2	19	Top Board 1 (Hutch)	x1	20	Back Board 3 (Hutch)	x1
21	Back Board 4 (Hutch)	x1	22	Top Board 2 (Hutch)	x1	23	Top Board 3 (Hutch)	x1	24	Top Board 4 (Hutch)	x1
25	Back Board 3 (Hutch)	x1									

**STEP 1:**

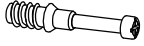

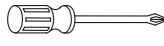

		
Ax7	Cx20	Xx1

Hardware required.  
Screwdriver not included

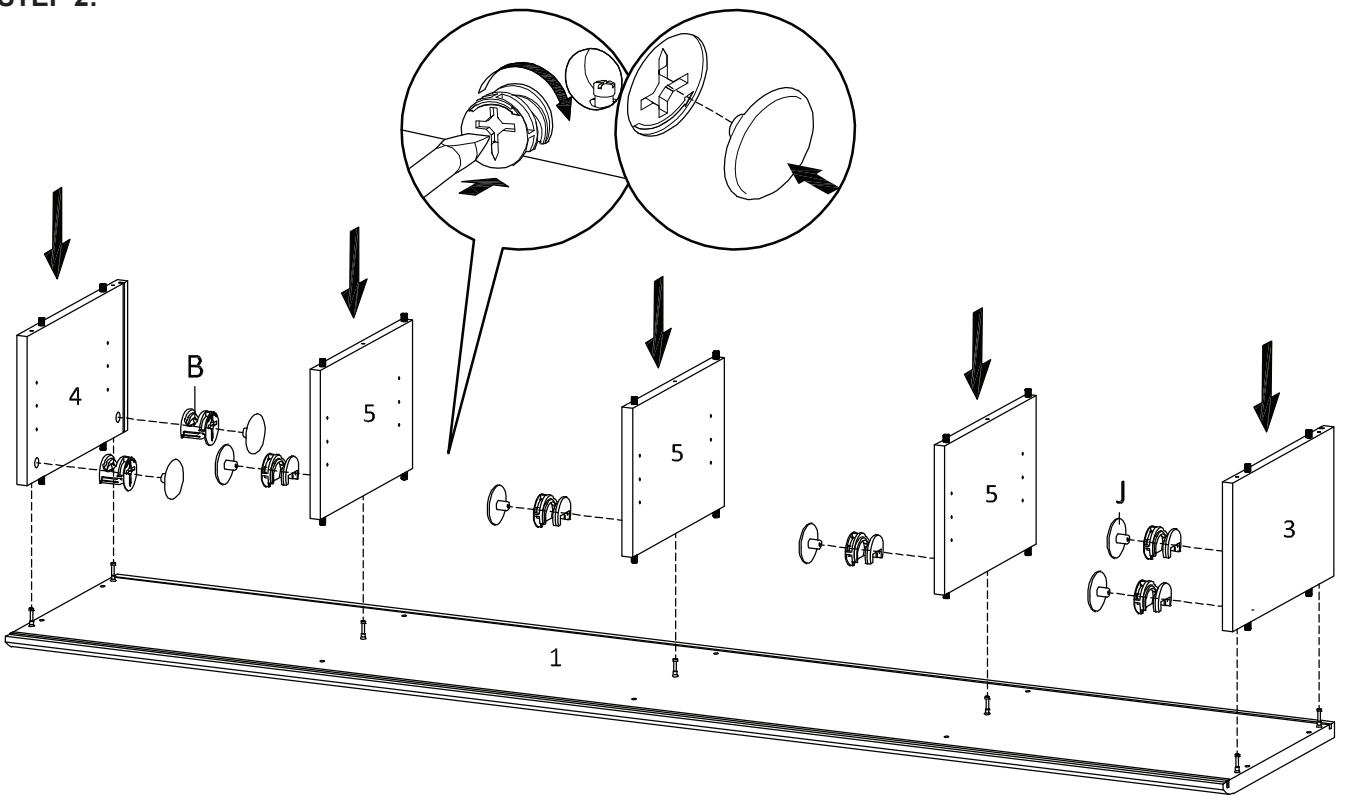
**STEP 2:**



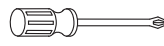

		
Bx7	Jx7	Xx1

Hardware required.  
Screwdriver not included

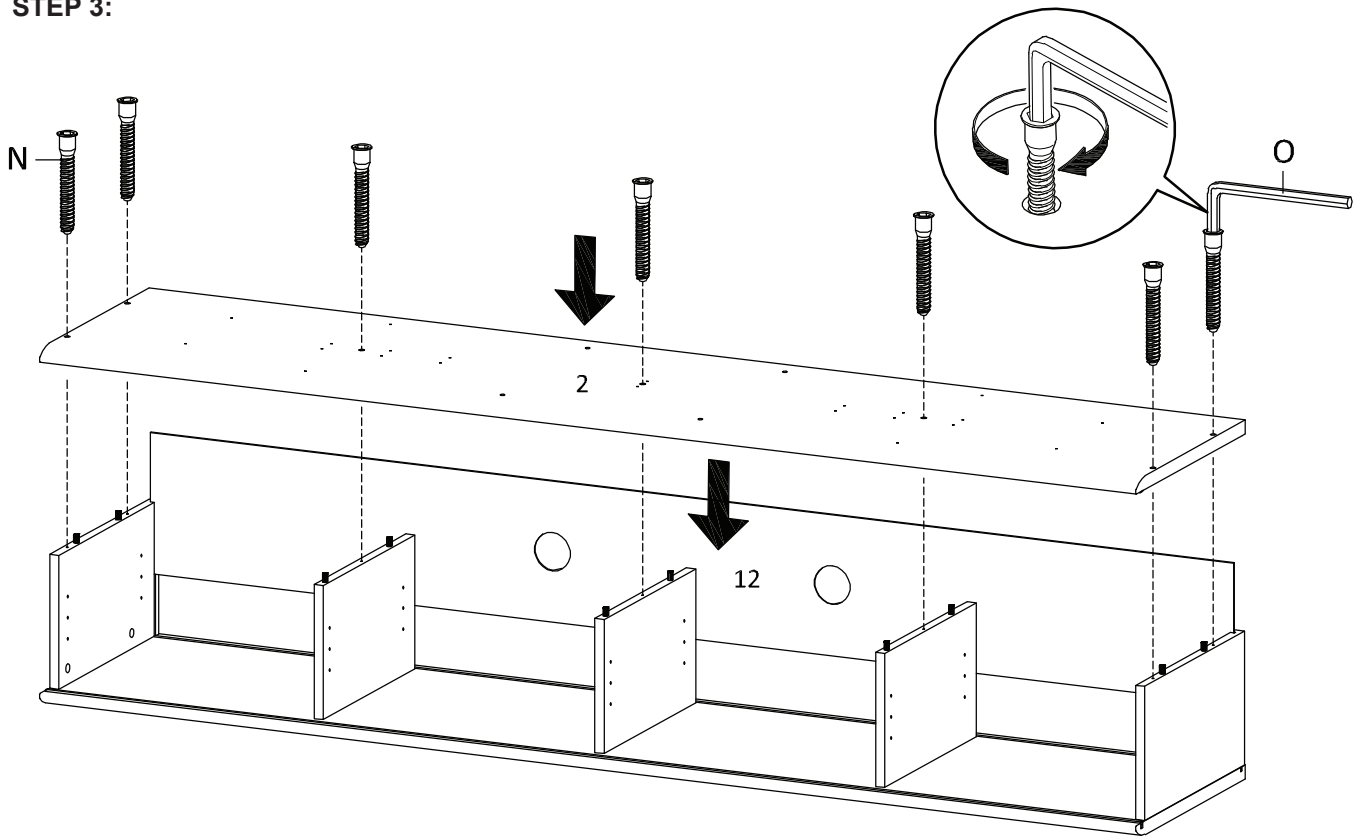
**STEP 3:**

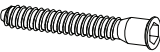



	
Nx7	Ox1

Hardware required.

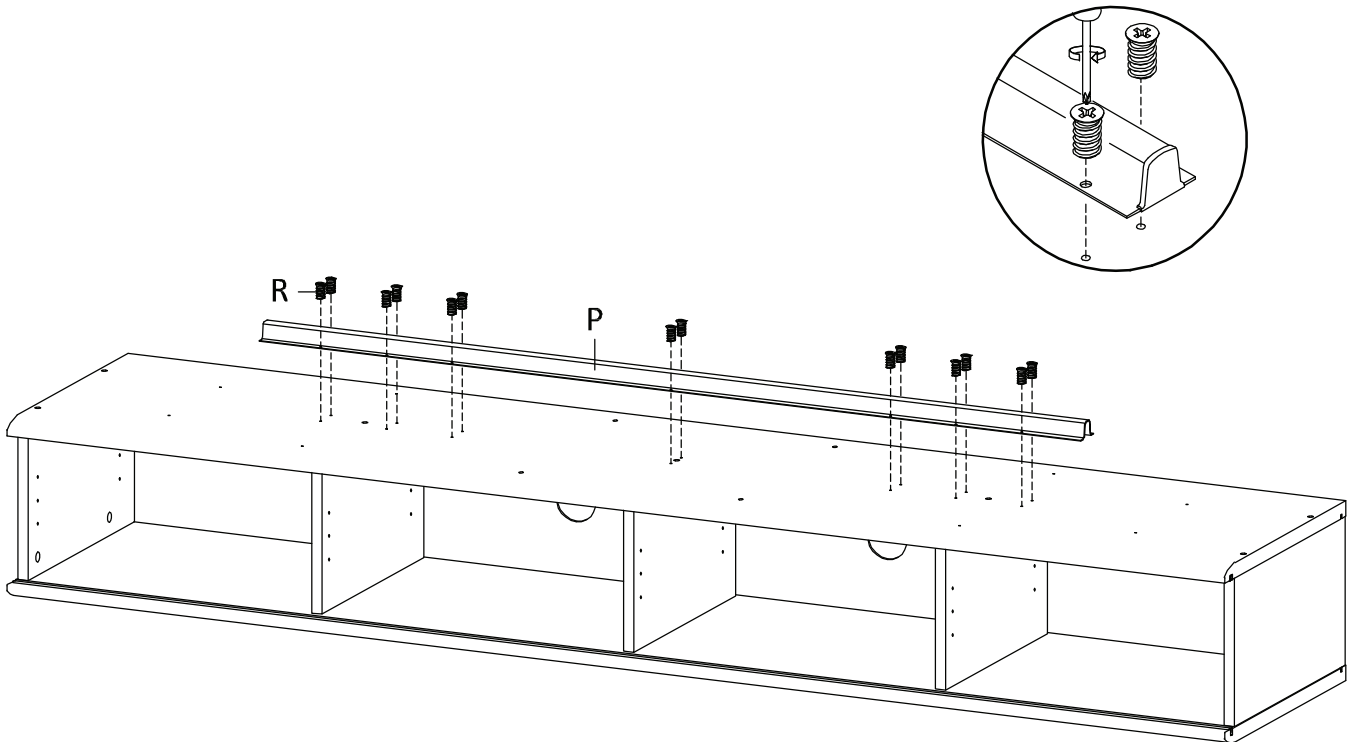
**STEP 4:**



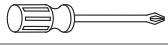

		
Px1	Rx14	Xx1

Hardware required.  
Screwdriver not included

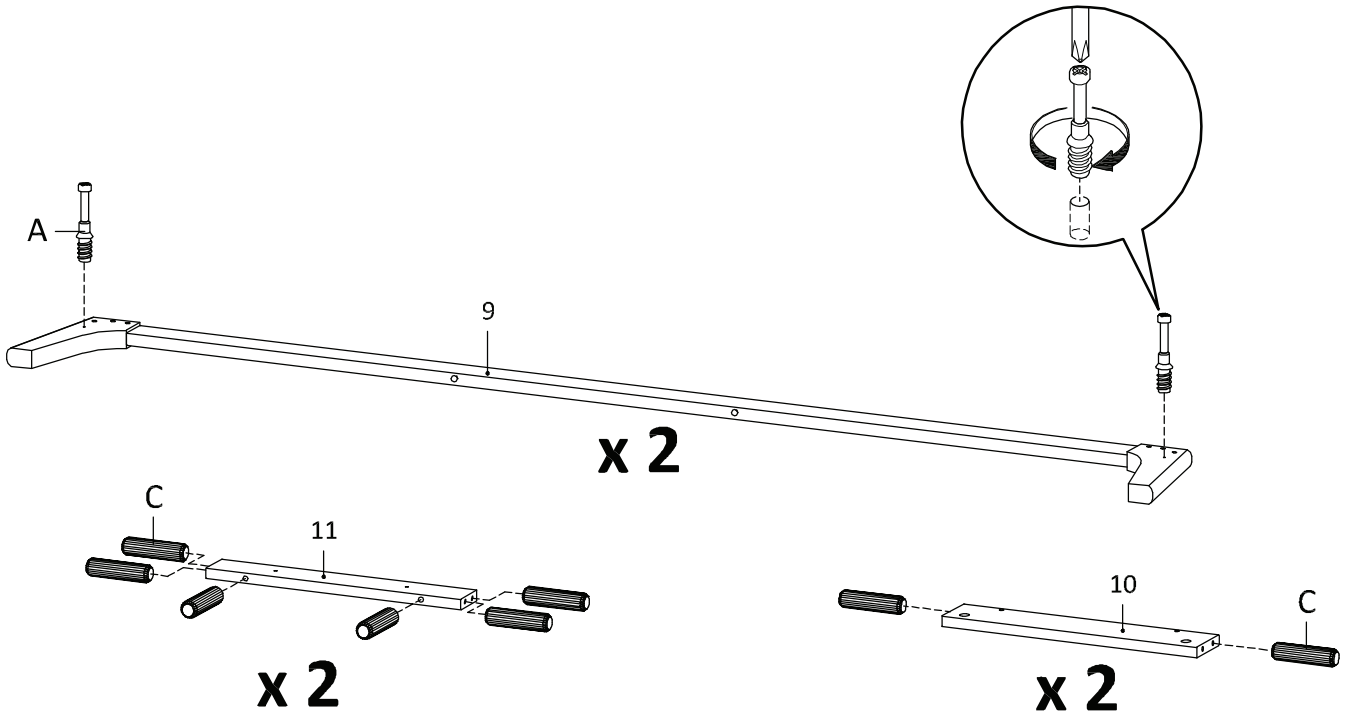
**STEP 5:**

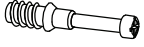

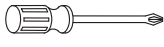
		
Ax4	Cx16	Xx1

Hardware required.  
Screwdriver not included

**STEP 6:**

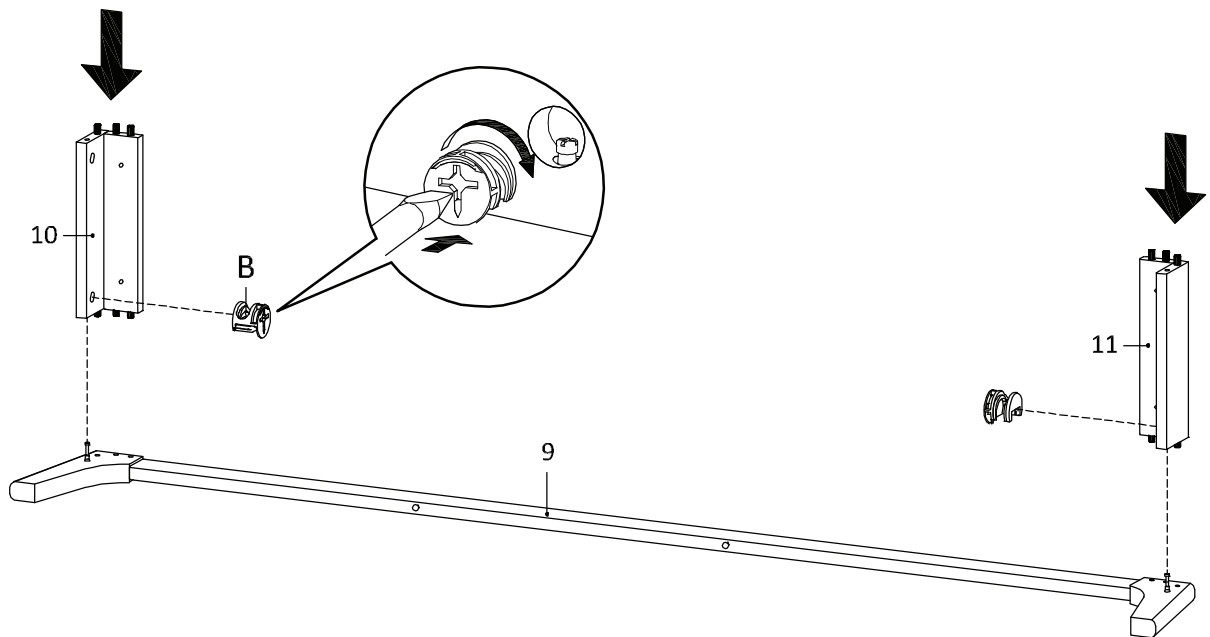

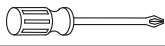

	
Bx2	Xx1

Hardware required.  
Screwdriver not included

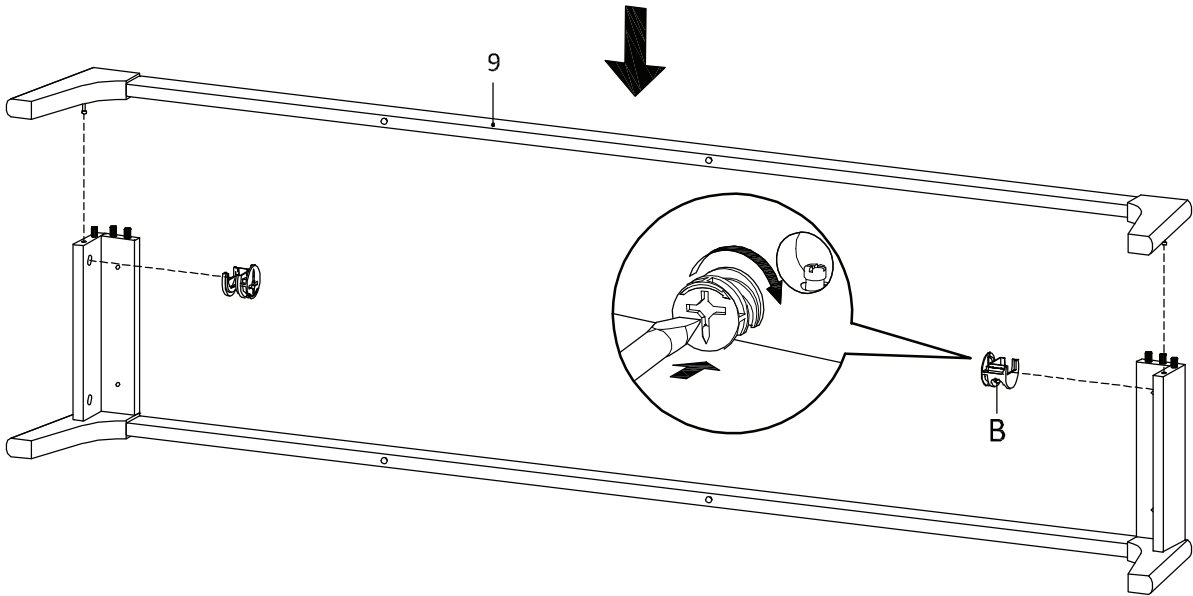
**STEP 7:**



	
Bx2	Xx1

Hardware required.  
Screwdriver not included

**STEP 8:**

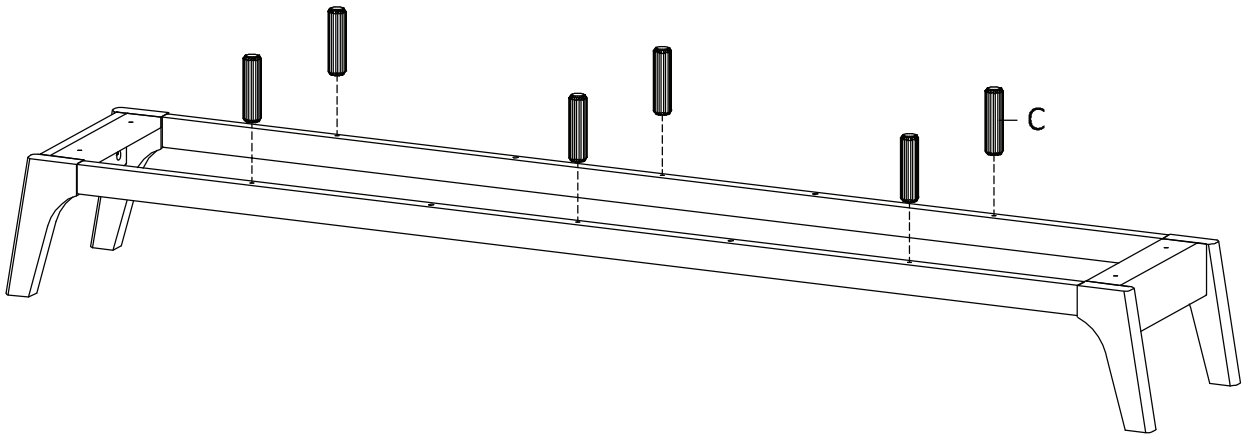





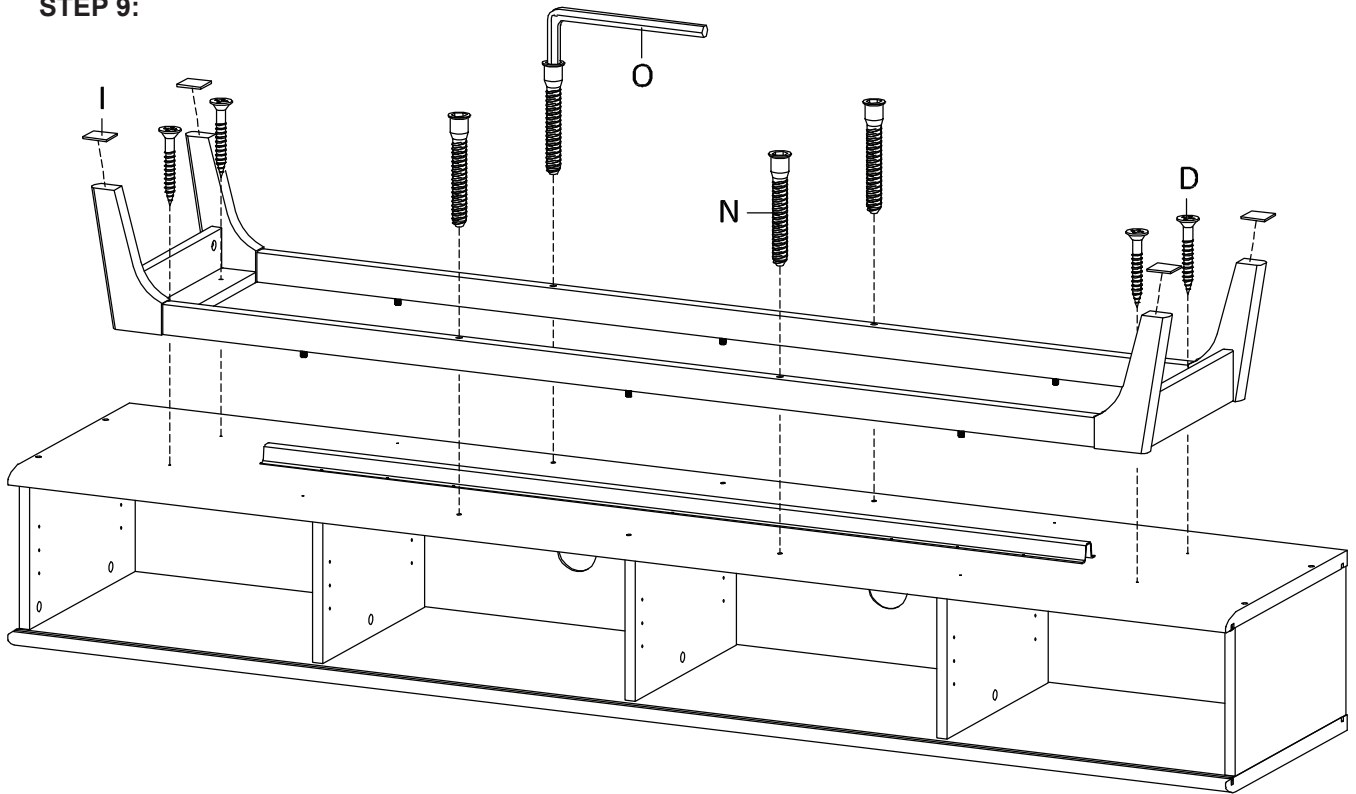

Cx6

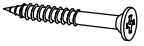
Hardware required.

**STEP 9:**

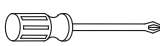

				
Dx4	Ix4	Nx4	O	Xx1

Hardware required.  
Screwdriver not included

**STEP 10:**

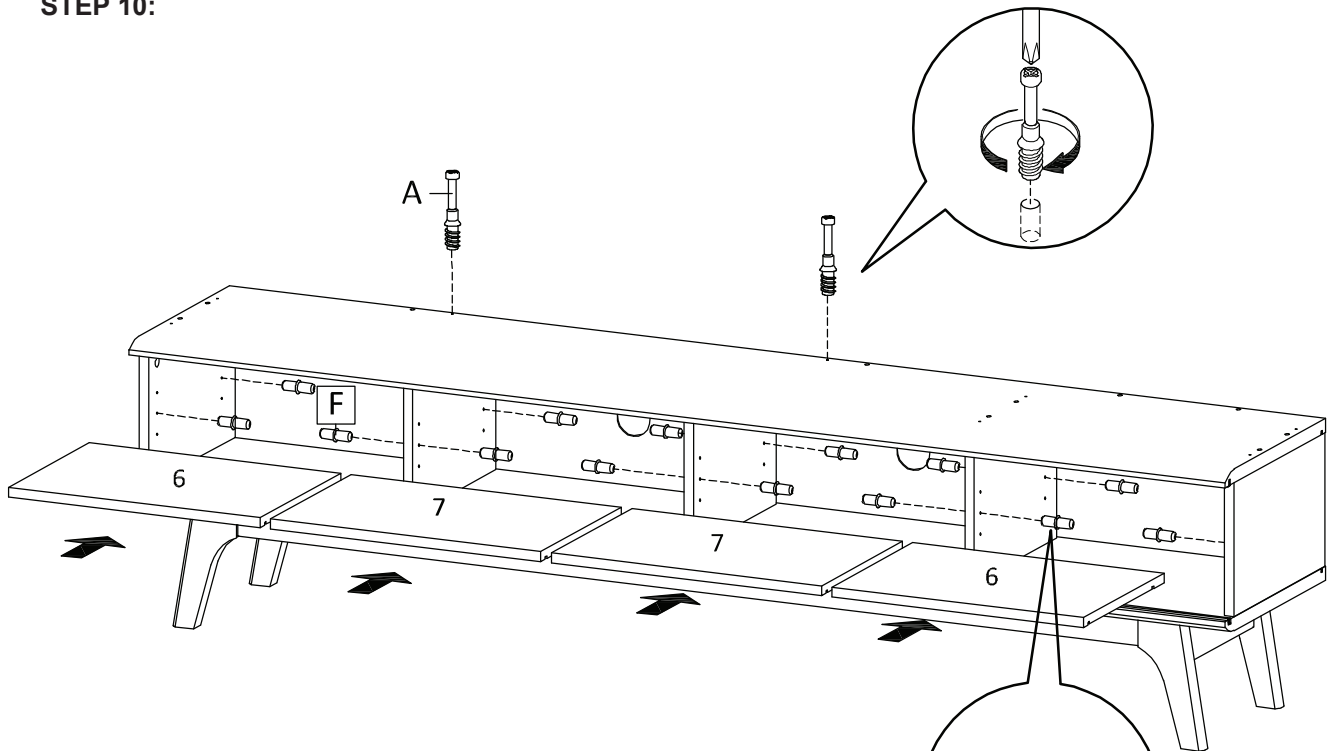

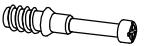
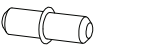
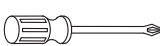
		
Ax2	Fx16	Xx1

Hardware required.  
Screwdriver not included

**STEP 11:**

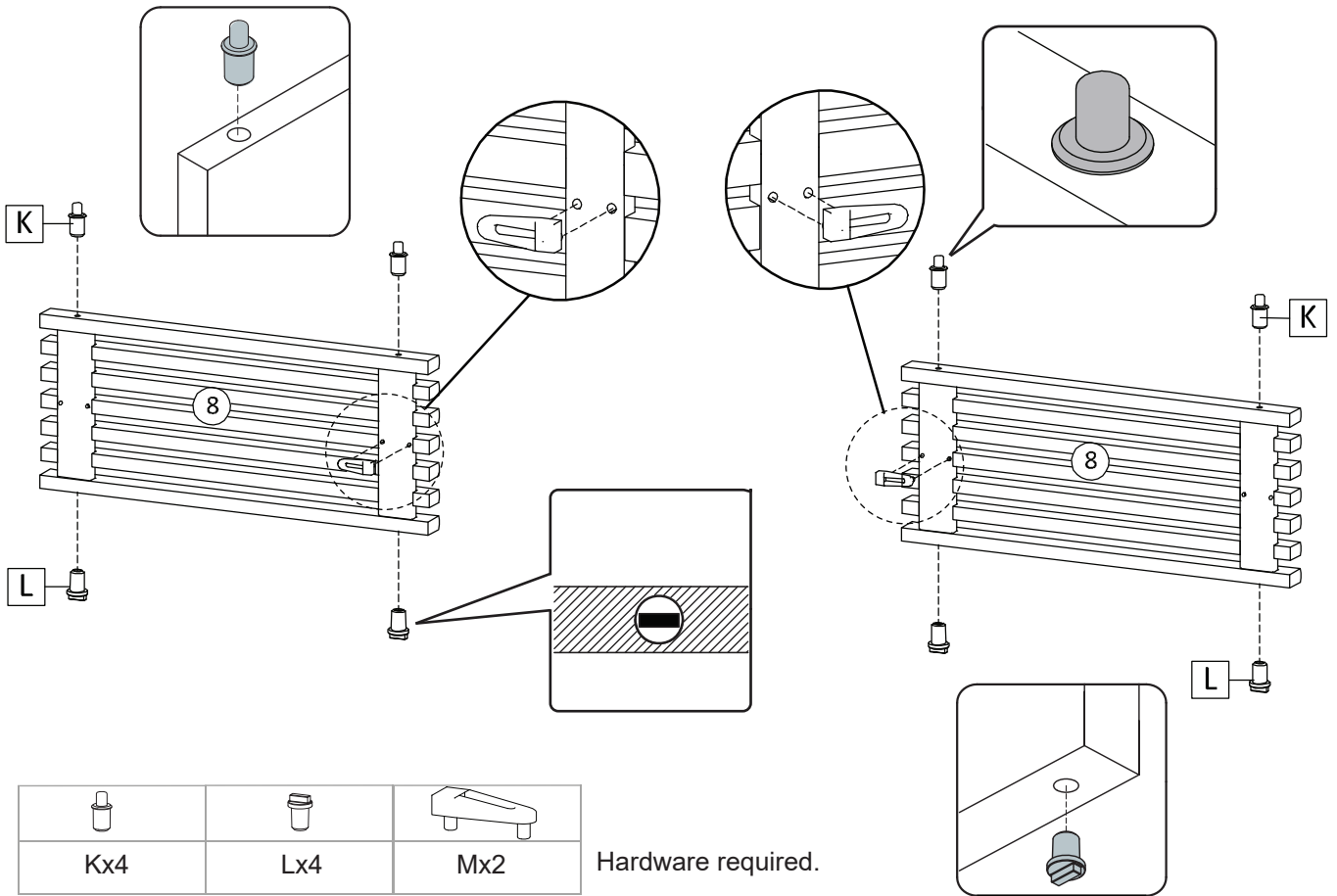

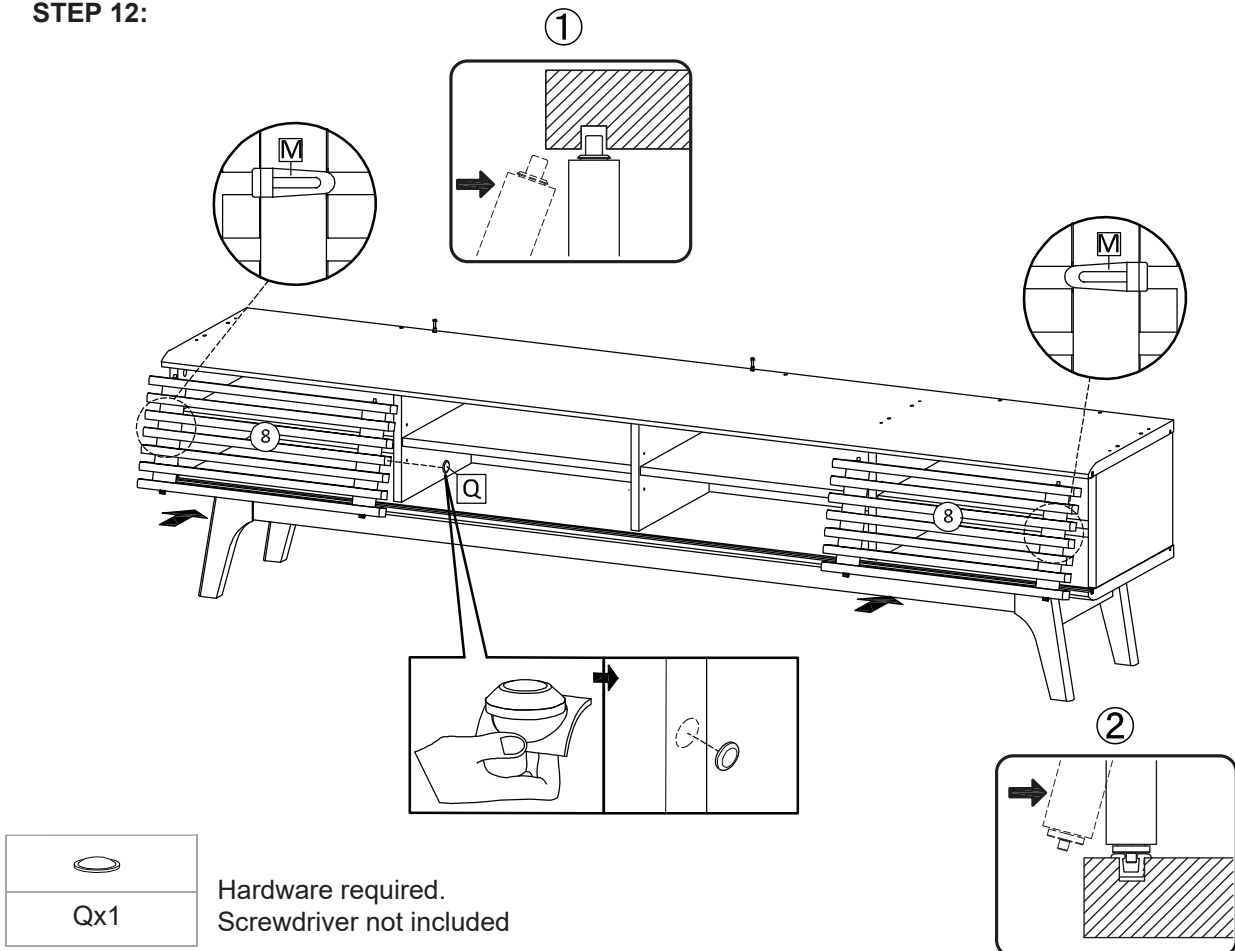

**STEP 12:**

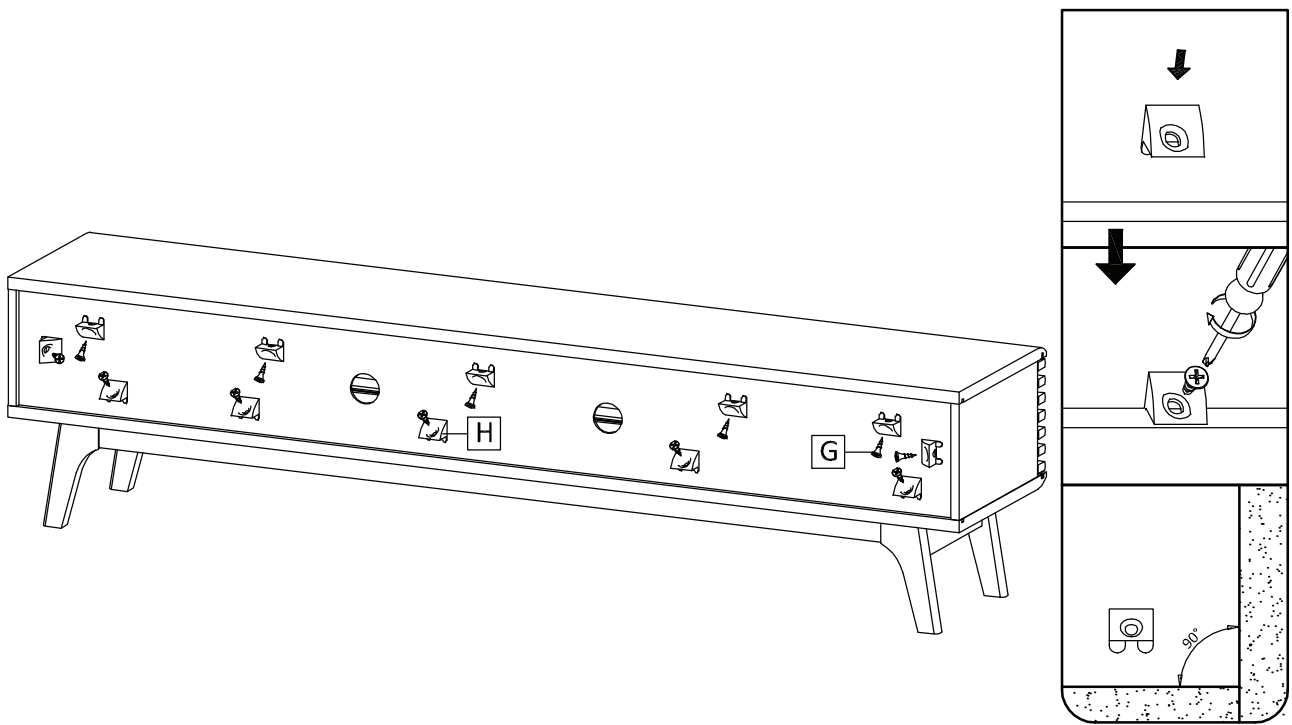

**STEP 13:**

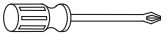

		
Gx12	Hx12	Xx1

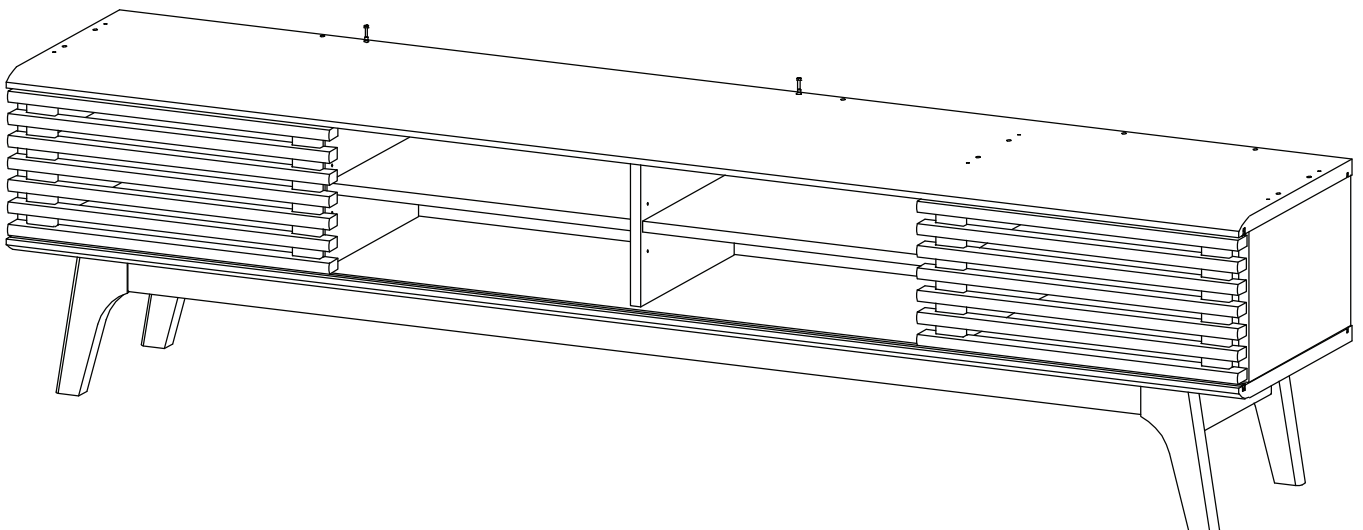

Hardware required.  
Screwdriver not included

**STEP 14:**

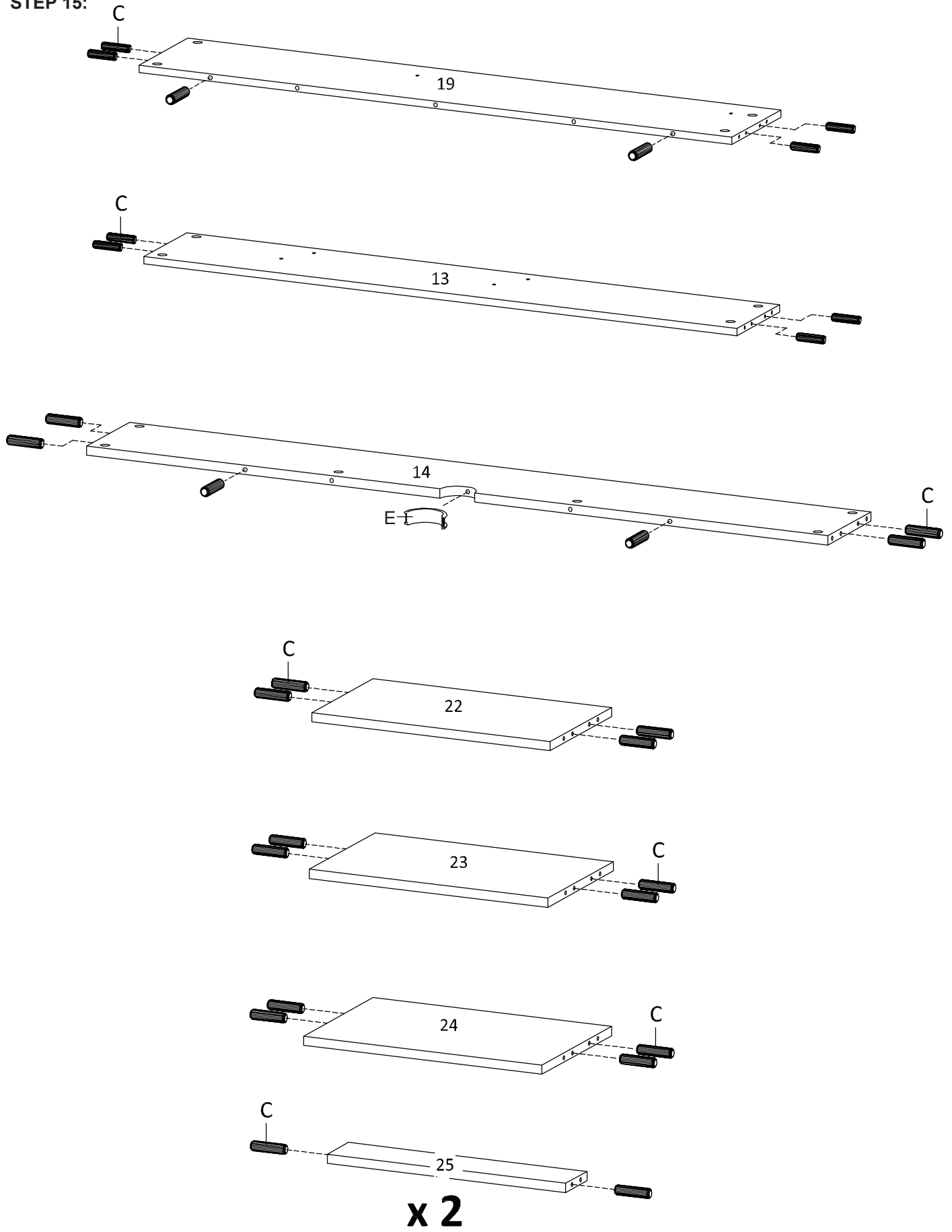

STEP 15:





	
Cx32	Ex1

Hardware required.

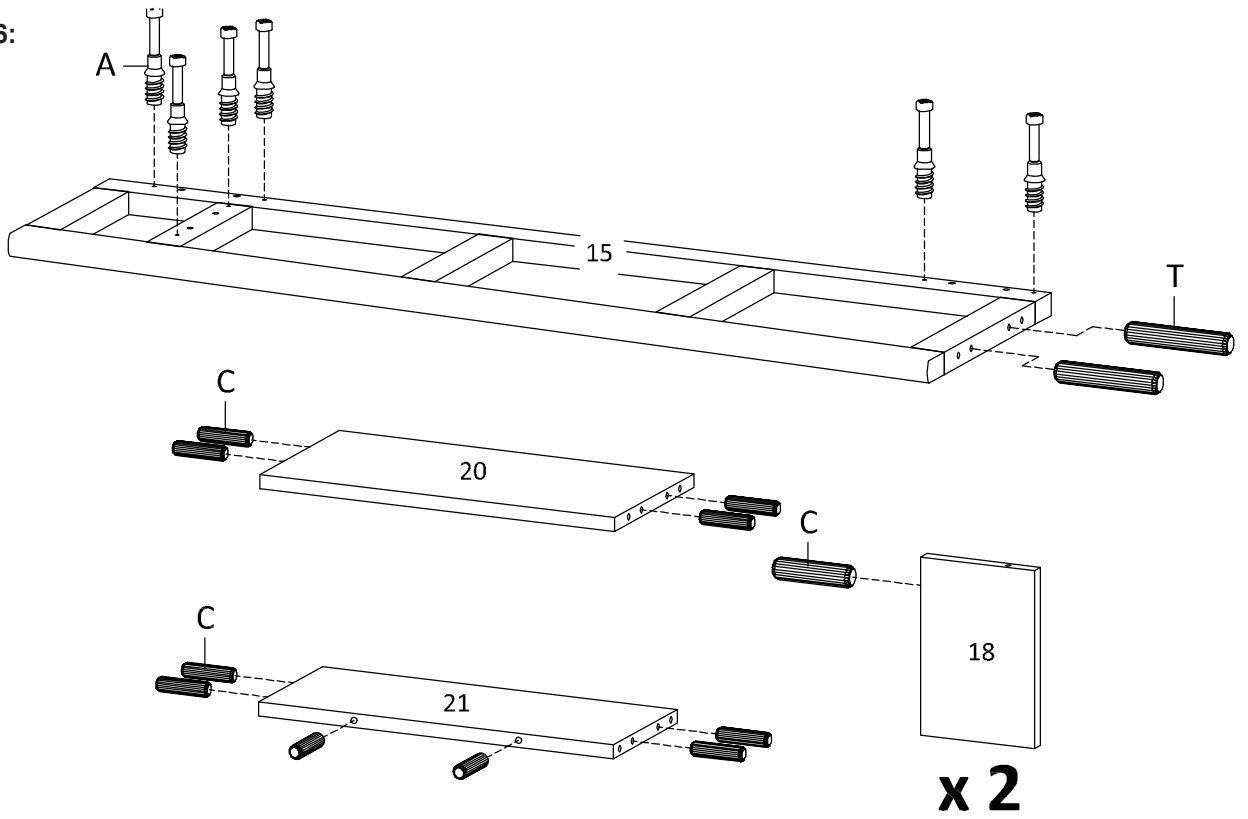
**STEP 16:**



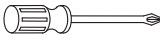

			
Ax6	Cx12	Tx2	Xx1

Hardware required.  
Screwdriver not included

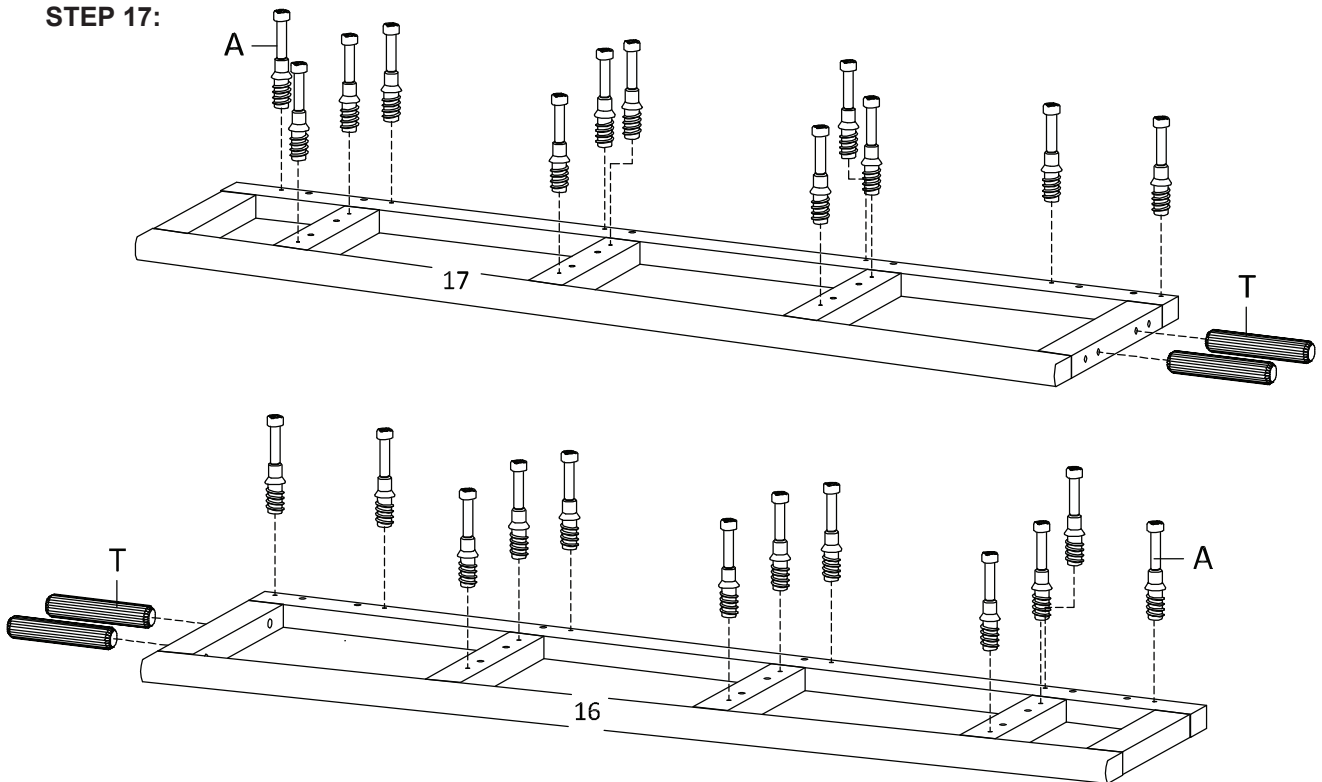
**STEP 17:**

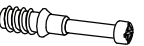

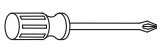

		
Ax24	Tx4	Xx1

Hardware required.  
Screwdriver not included

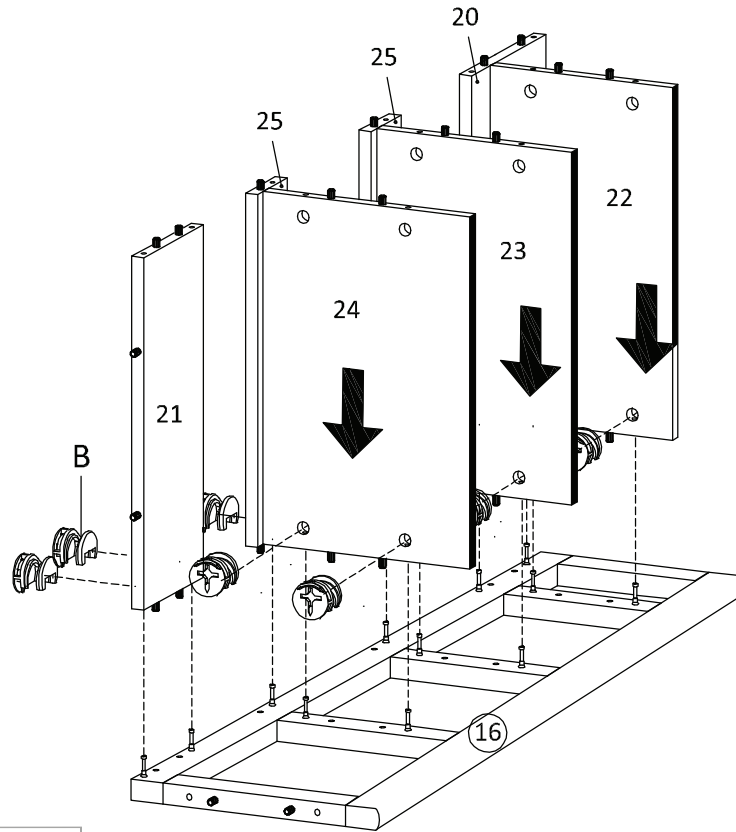
**STEP 18:**





	
Bx12	Xx1

Hardware required.  
Screwdriver not included

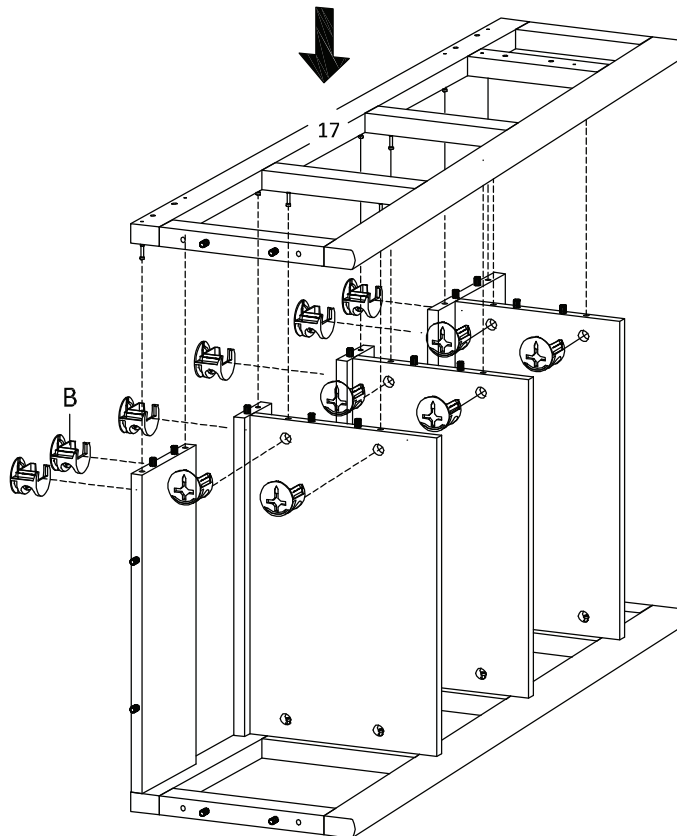
**STEP 19:**





	
Bx12	Xx1

Hardware required.  
Screwdriver not included

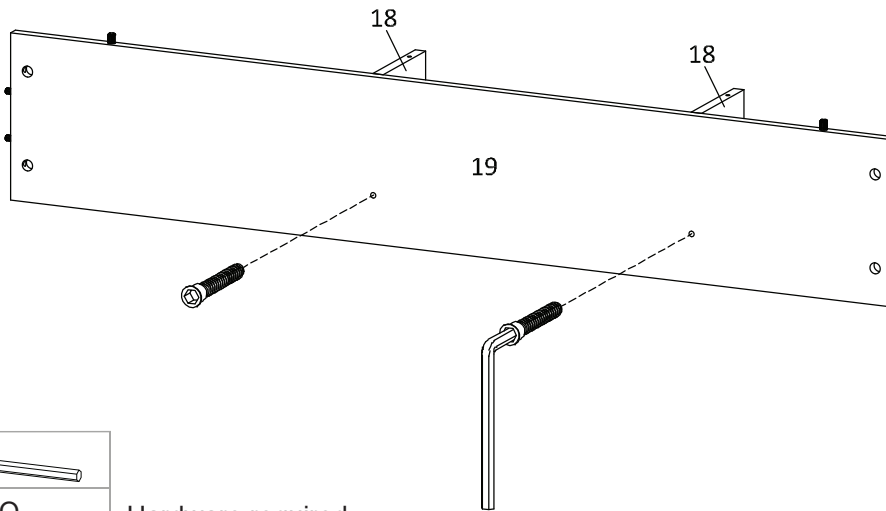
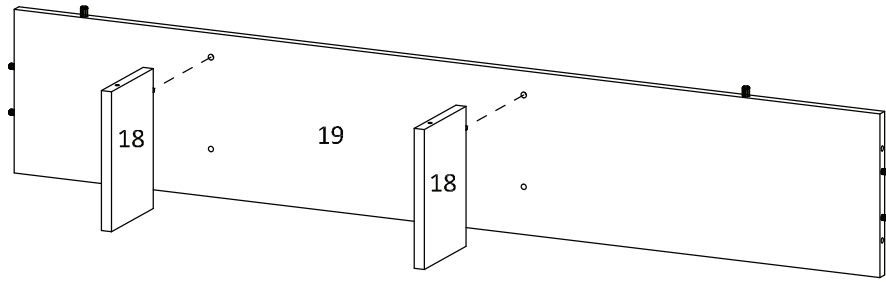
**STEP 20:**

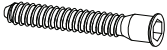



	
Nx2	O

Hardware required.

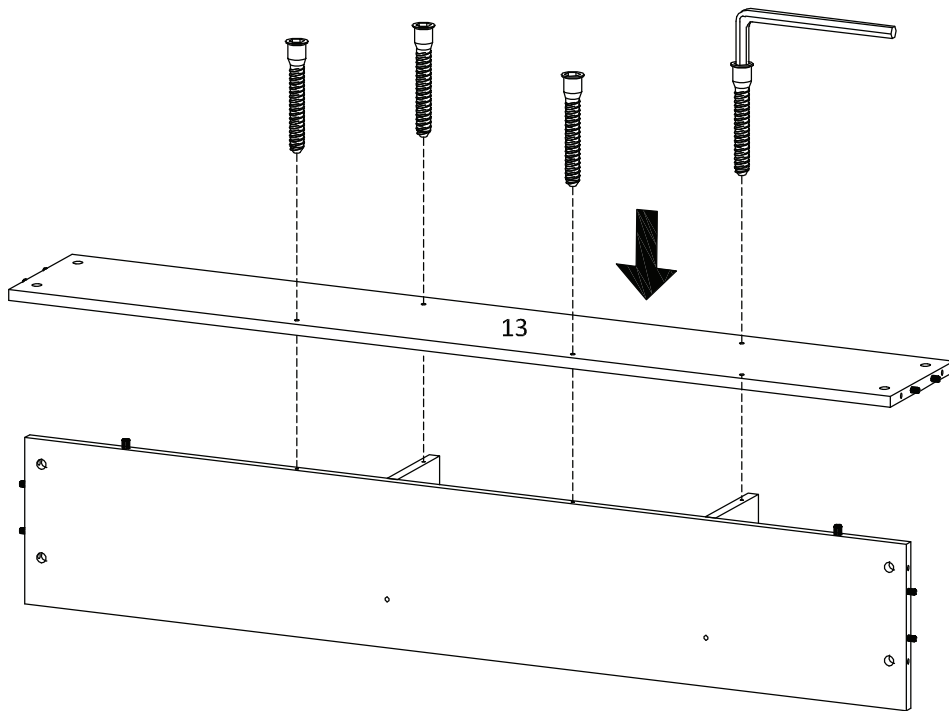
**STEP 21:**



	
Nx4	O

Hardware required.

**STEP 22:**

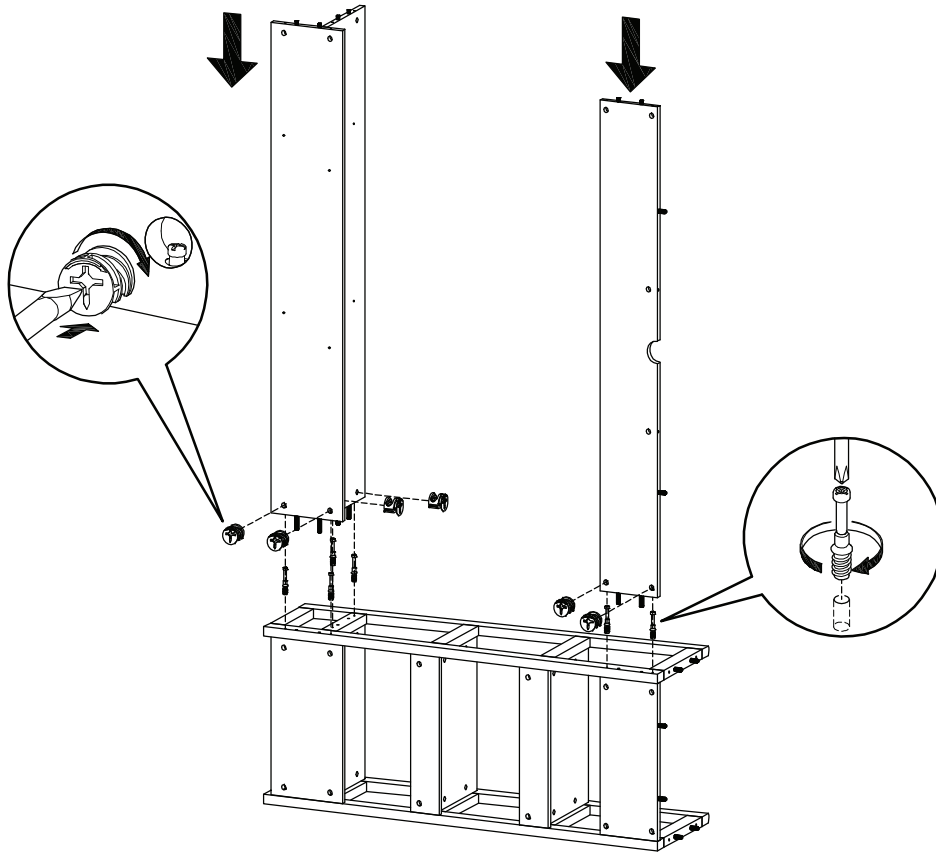

		
Ax6	Bx6	Xx1

Hardware required.  
Screwdriver not included

**STEP 23:**

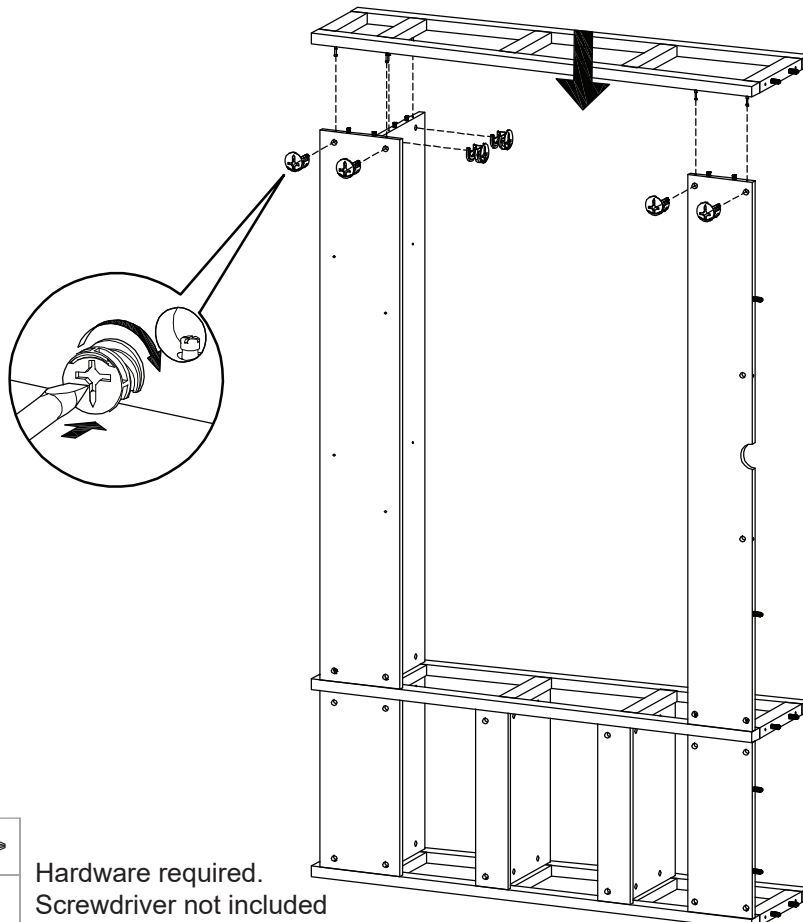

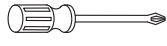

	
Bx6	Xx1

Hardware required.  
Screwdriver not included

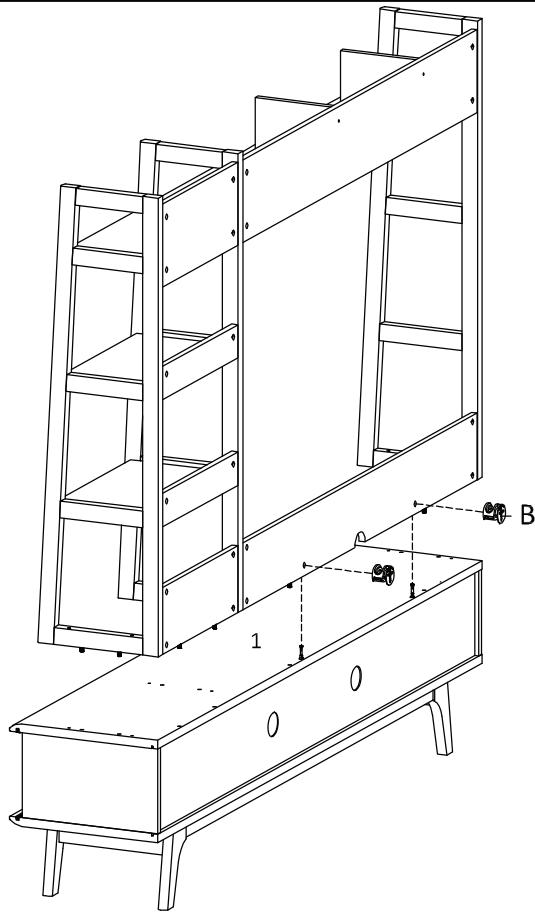
**STEP 24:**





	
Bx2	Xx1

Hardware required.  
Screwdriver not included

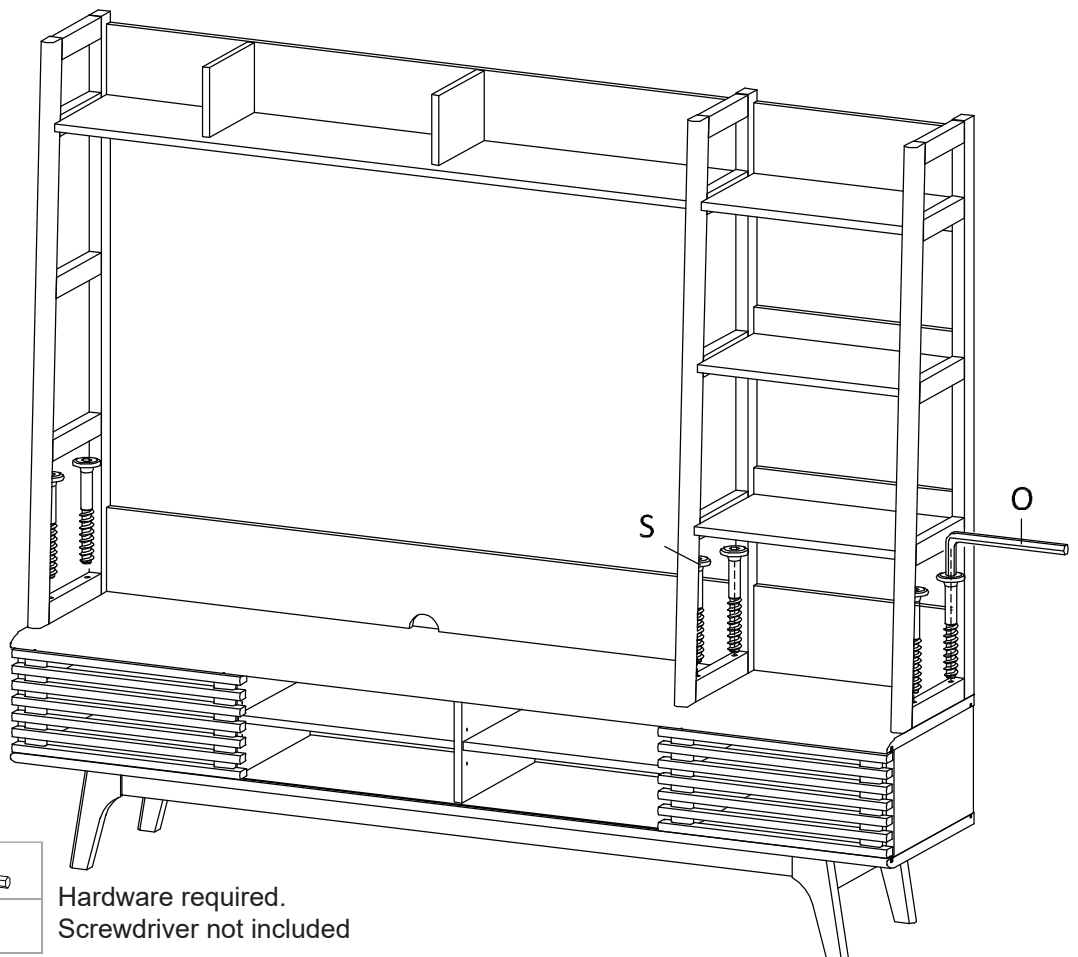
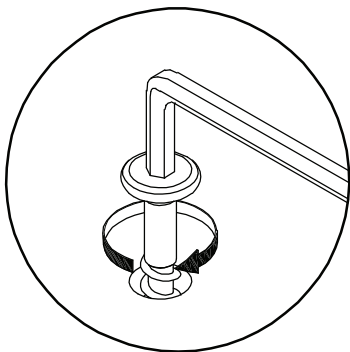
**STEP 25:**



	
Sx6	O

Hardware required.  
Screwdriver not included

**STEP 26:**

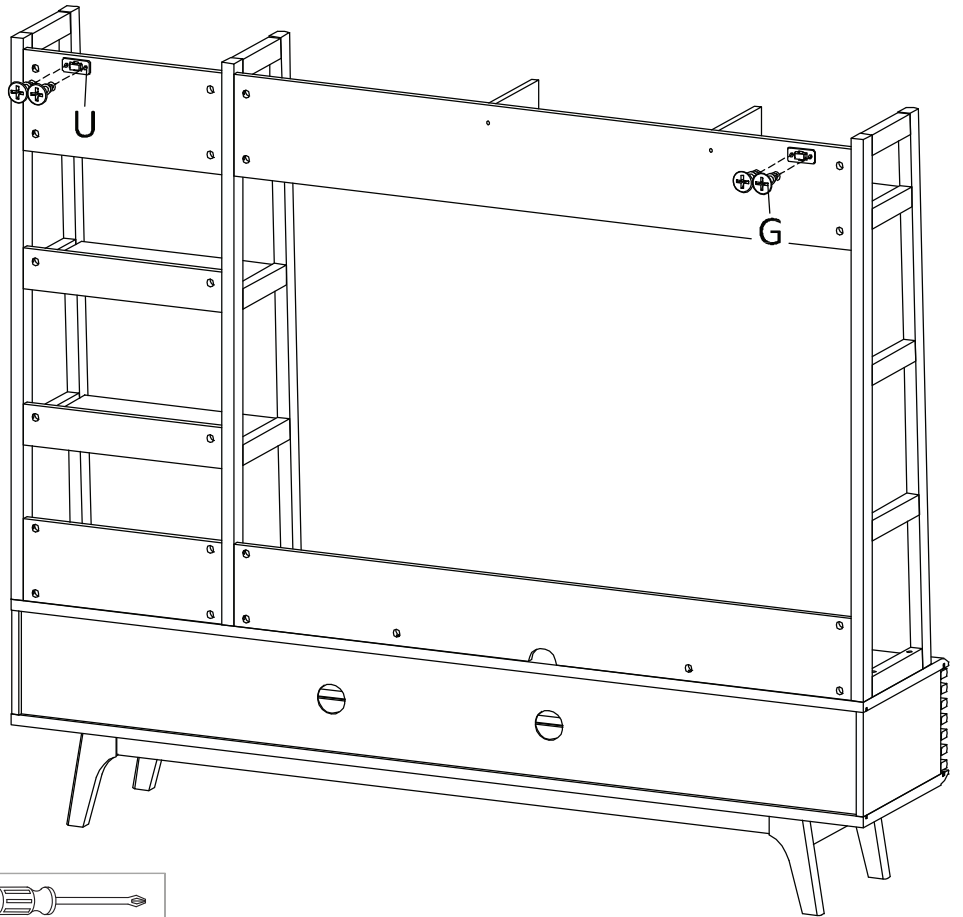
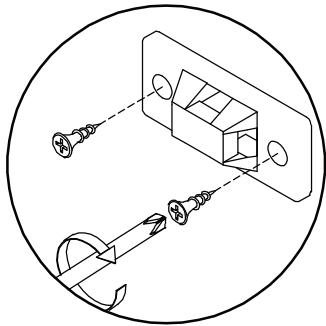

Ux2	Gx4	Xx1

Hardware required.  
Screwdriver not included

**STEP 27:**

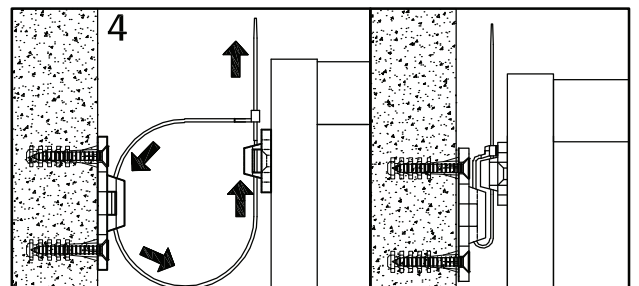
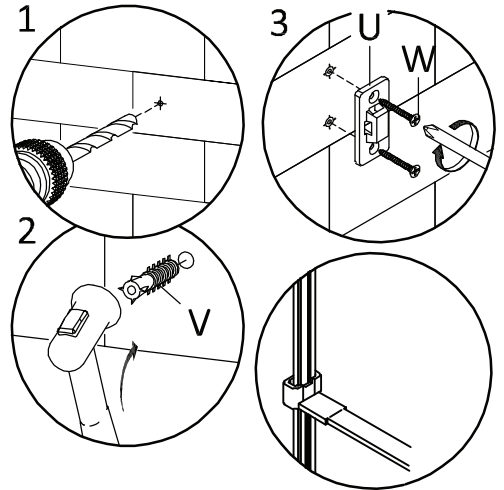
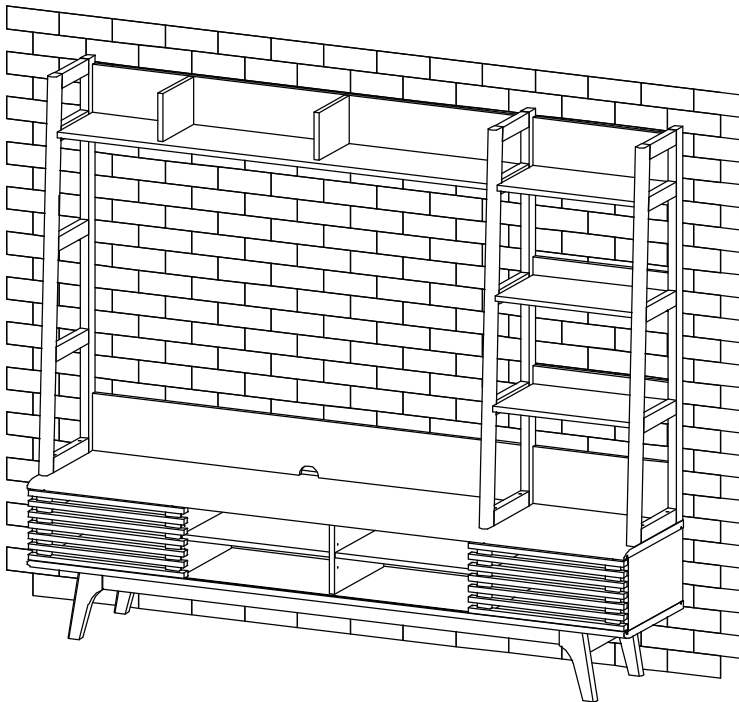

Vx4	Wx4	Xx1

Hardware required.  
Screwdriver not included

---

**STEP 23:**

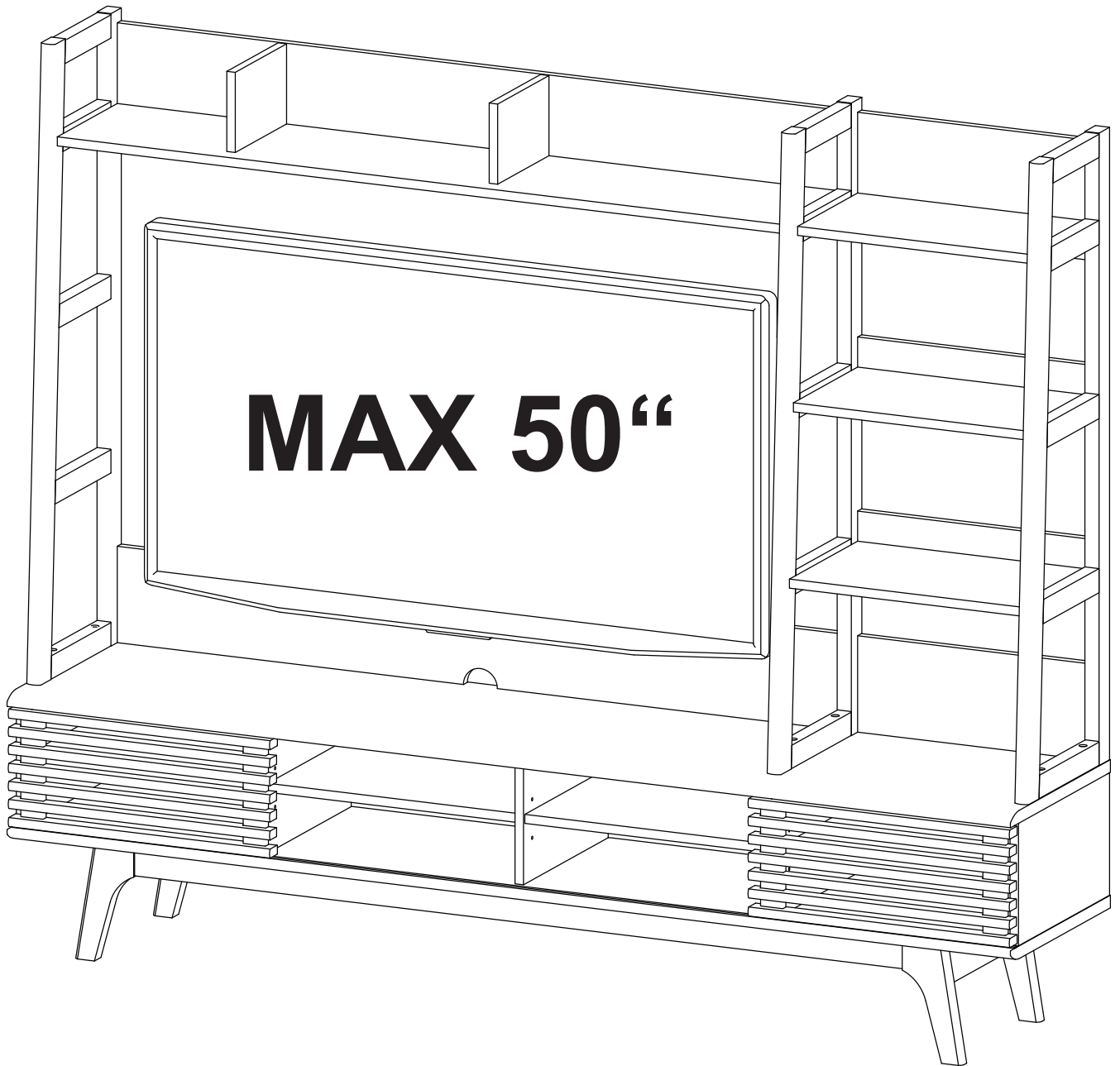

**Assembly is complete. The TV Stand is ready to enjoy now !**