

Pure & Easy

ASSEMBLY INSTRUCTIONS

GDOSOS-0034
GDOSOS-0035 GDOSOS-0040 GDOSOS-0045
GDOSOS-0036 GDOSOS-0041 GDOSOS-0046
GDOSOS-0037 GDOSOS-0042 GDOSOS-0047
GDOSOS-0038 GDOSOS-0043 GDOSOS-0048
GDOSOS-0039 GDOSOS-0044 GDOSOS-0049

YXJJ-V1

NOTICE

IMPORTANT, RETAIN FOR FUTURE REFERENCE: READ CAREFULLY
WICHTIG, FÜR SPÄTERE NACHSCHLAGE AUFBEWAHREN: SORGFÄLTIG LESEN
IMPORTANTE, GUARDAR PARA REFERENCIA FUTURA: LEER ATENTAMENTE
IMPORTANTE, CONSERVARE PER RIFERIMENTI FUTURI: LEGGERE ATTENTAMENTE
IMPORTANT, À CONSERVER POUR RÉFÉRENCE FUTURE : LIRE ATTENTIVEMENT

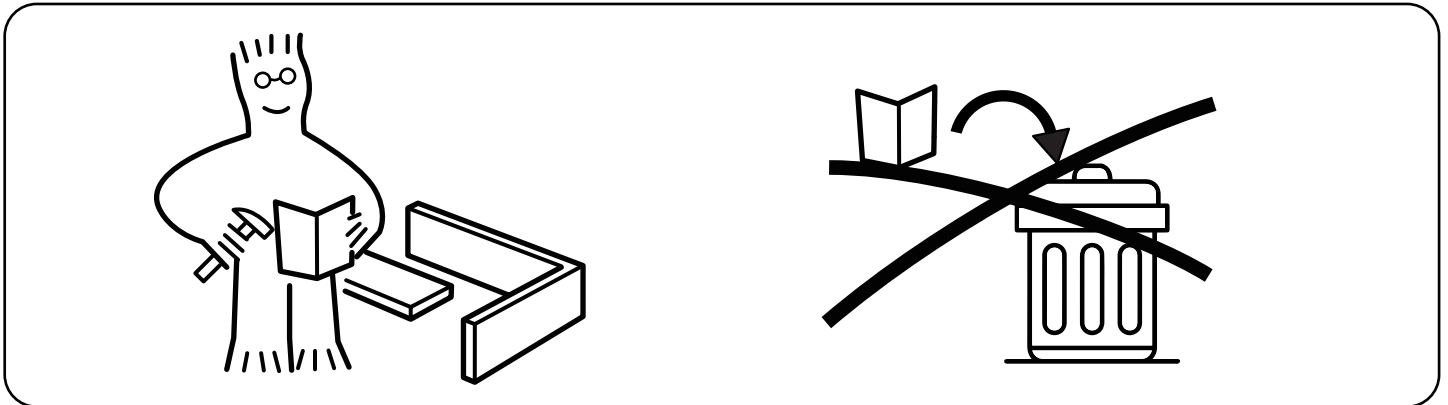

Assemble on a flat, clean and soft surface.
Auf einer flachen, sauberen und weichen Oberfläche zusammenbauen.
Assembler sur une surface plate, propre et douce.
Assemblare su una superficie piatta, pulita e morbida.
Ensamblar sobre una superficie plana, limpia y suave.

Professional installation is highly recommended.
Eine professionelle Installation wird dringend empfohlen.
Une installation professionnelle est fortement recommandée.
Si raccomanda vivamente l'installazione professionale.
Se recomienda altamente la instalación profesional.



Periodically Check That All Components Are Tightly Secured.
Überprüfen Sie Regelmäßig, Dass Alle Komponenten Fest Gesichert Sind.
Vérifiez Périodiquement Que Tous Les Composants Sont Bien Fixés.
Controllare Periodicamente Che Tutti I Componenti Siano Ben Fissati.
Verifique Periódicamente Que Todos Los Componentes Estén Bien Asegurados.

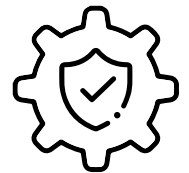



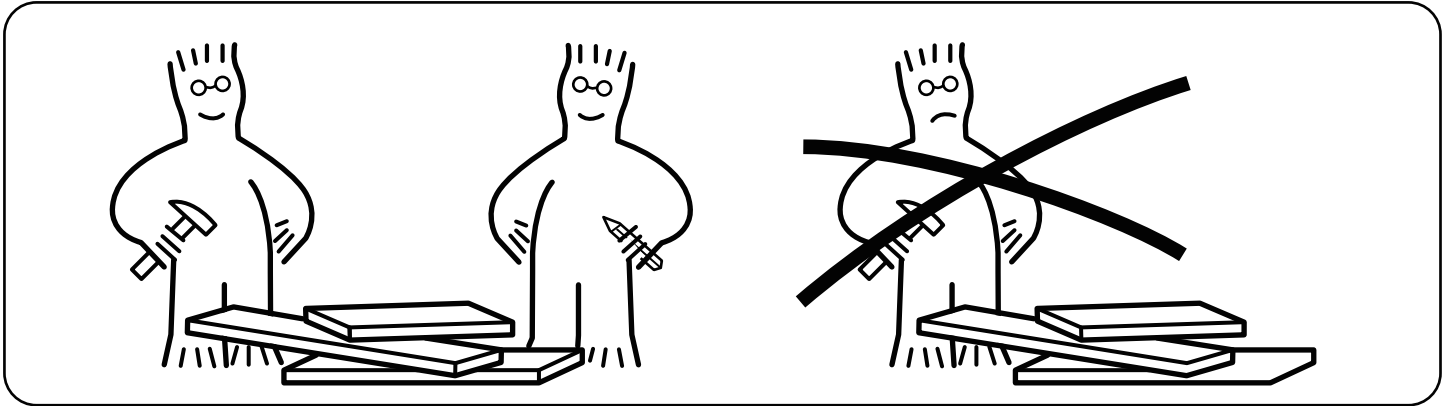

It is recommended that multiple people assemble this product.
Es wird empfohlen, dass mehrere Personen dieses Produkt zusammenbauen.
Il est recommandé que plusieurs personnes assemblent ce produit.
Si raccomanda che più persone assemblino questo prodotto.
Se recomienda que varias personas ensamblen este producto.

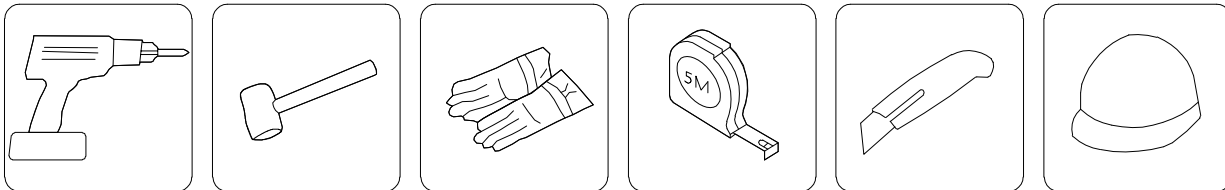

Please have the following auxiliary tools ready:

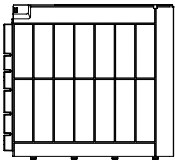
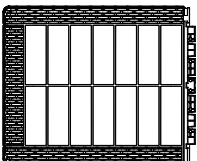
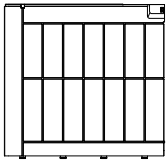
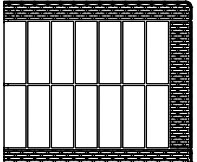
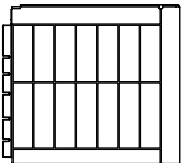
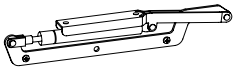
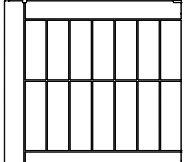

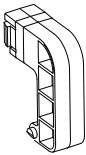
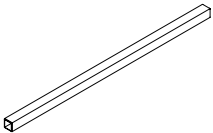
PARTS

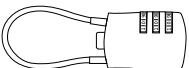
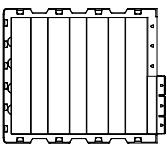
Item no.	Reference Image	Qty.	Item no.	Reference Image	Qty.
A1		X1	E1		X1
A2		X1	E2		X1
B1		X1	F		X2
B2		X1	G	 M4X16mm	X14 + 2extra
B3		X4	H		X3
C		X2	I		X1
D		X2			

EXPLODEDVIEW

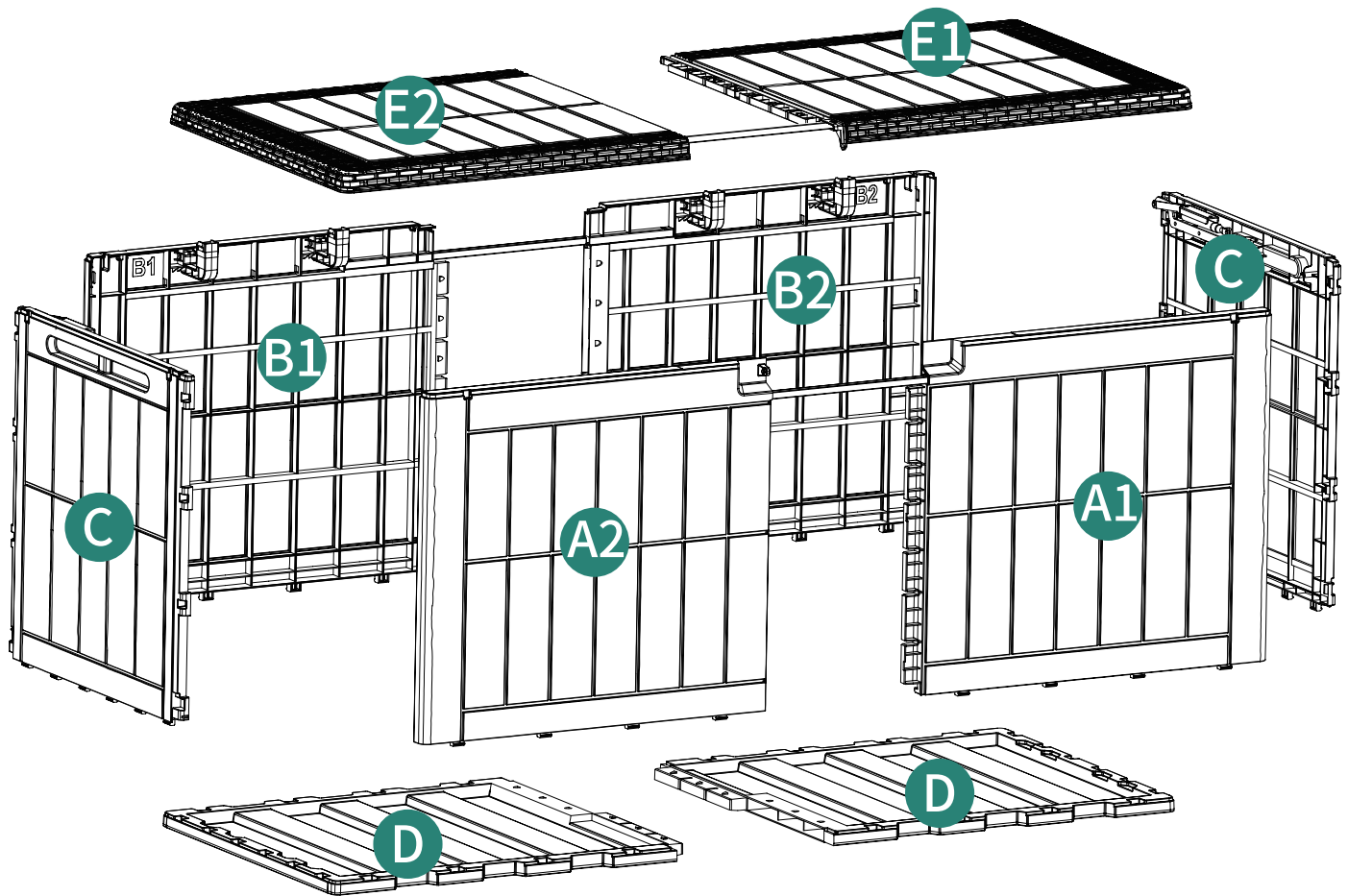

ASSEMBLY

1

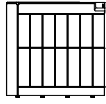

A2 1pc

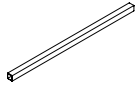

H 1pc

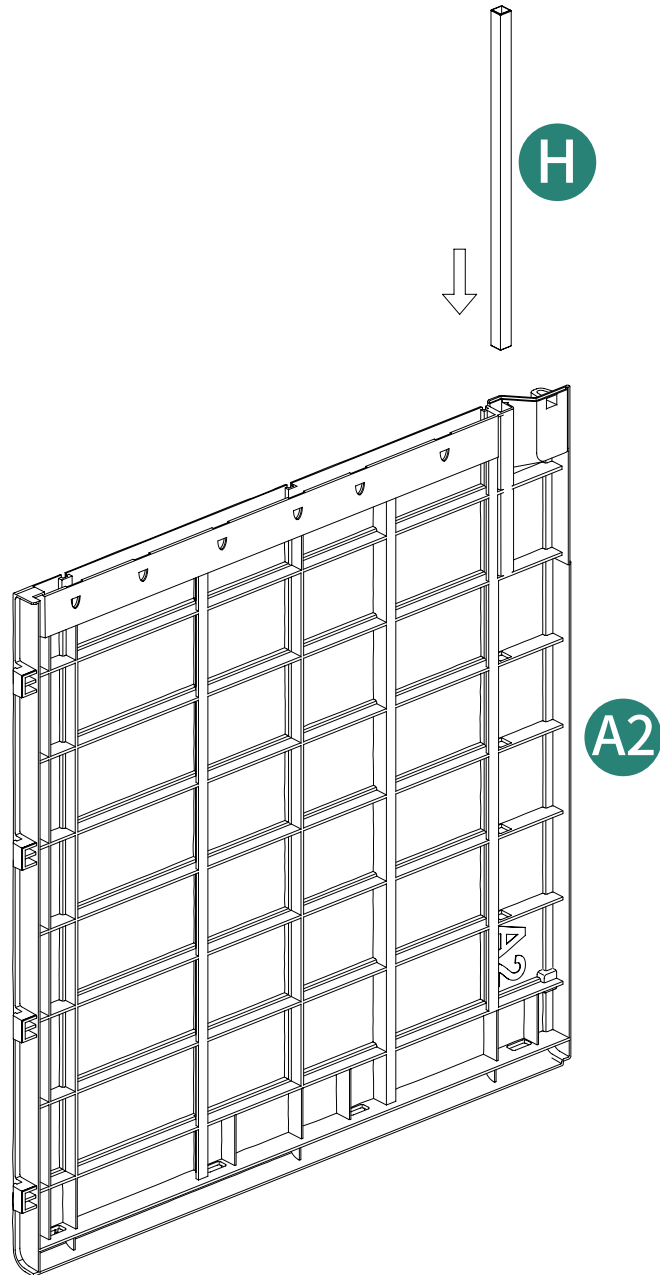

2

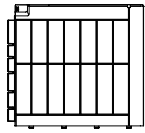

Ⓐ1 1pc

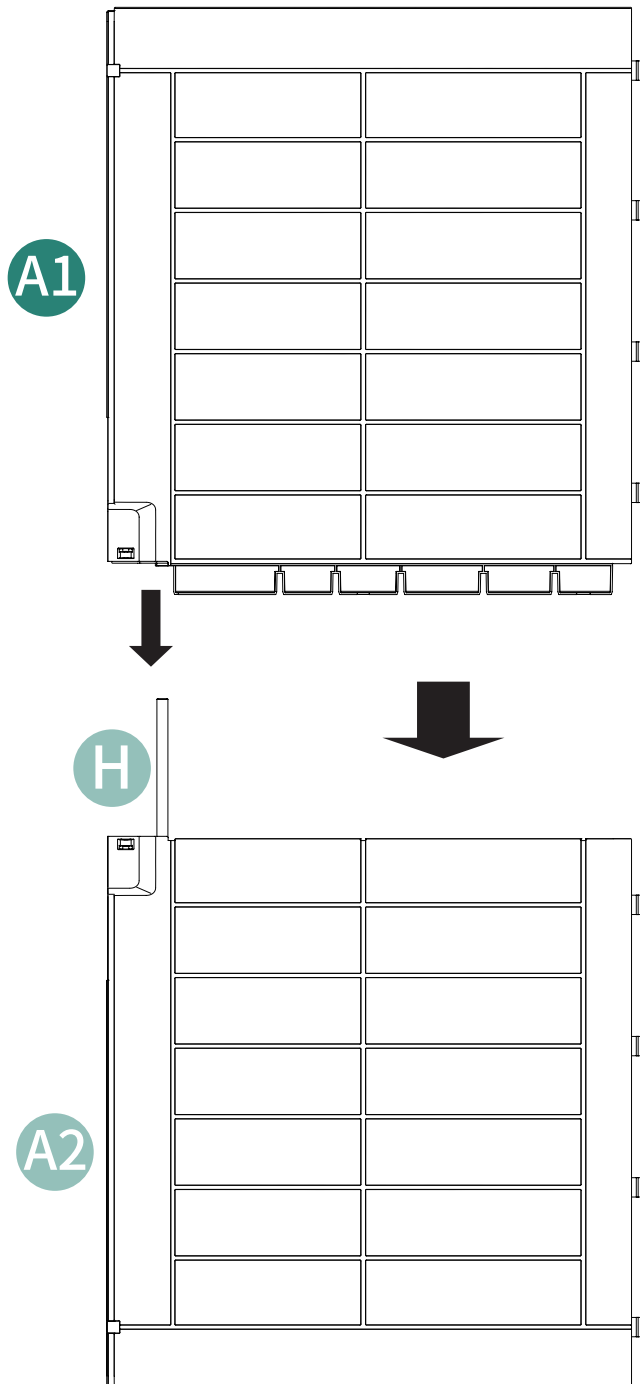
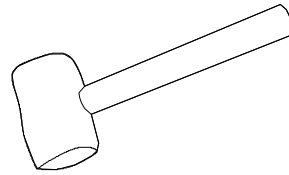

Please prepare rubber mallet in advance for convenient installation. Do not strike too hard to avoid shattering. A wooden board should be placed at the striking area for cushioning.

3

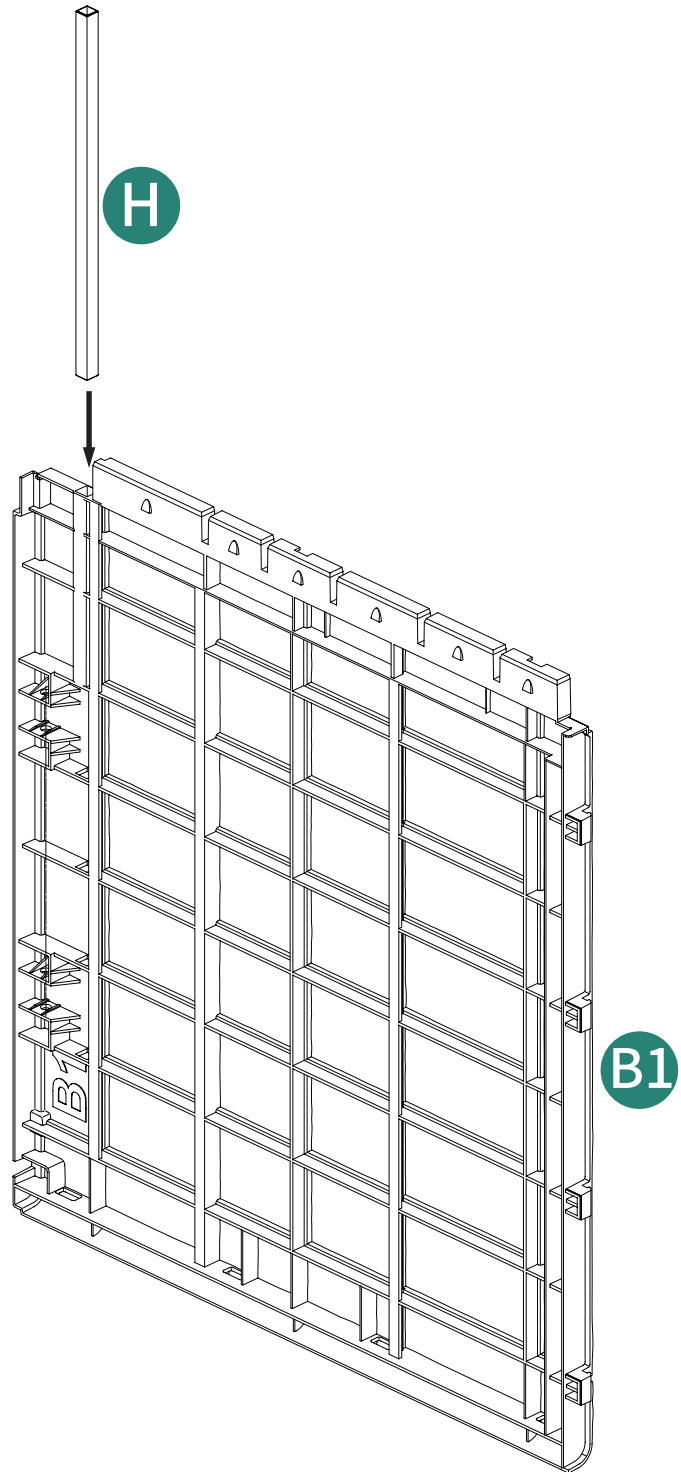
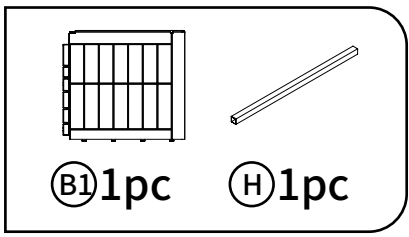

4

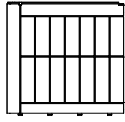

B2 1pc

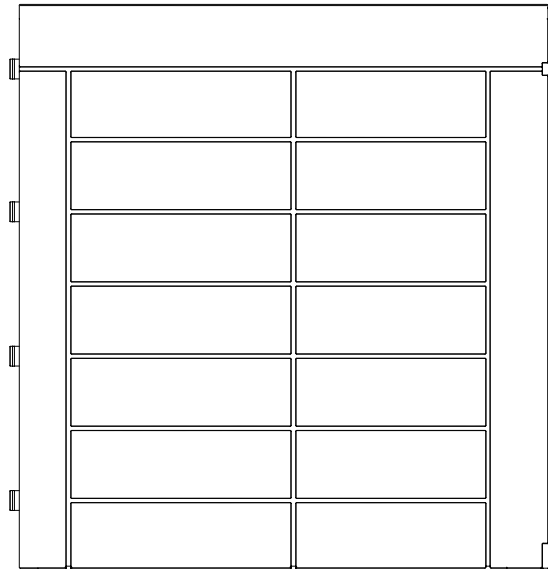
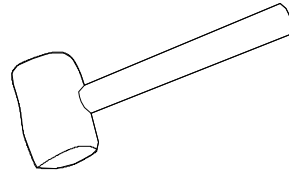

Please prepare rubber mallet in advance for convenient installation. Do not strike too hard to avoid shattering. A wooden board should be placed at the striking area for cushioning.

B2

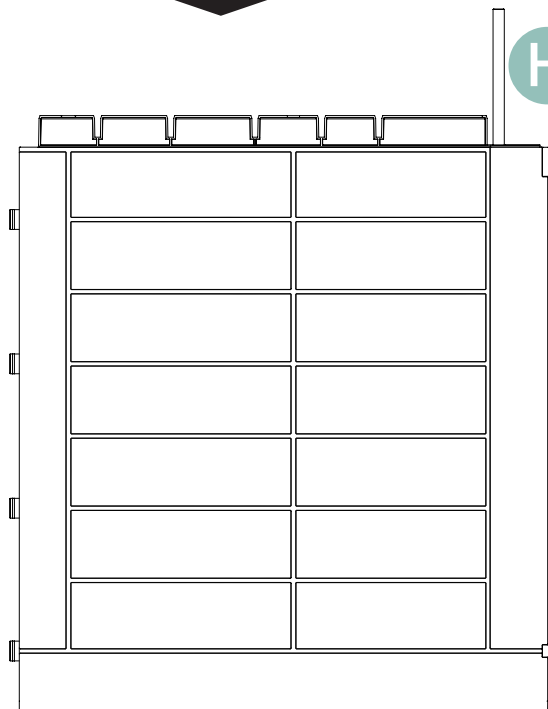

H

B1

5

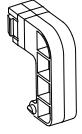

B3 4pcs

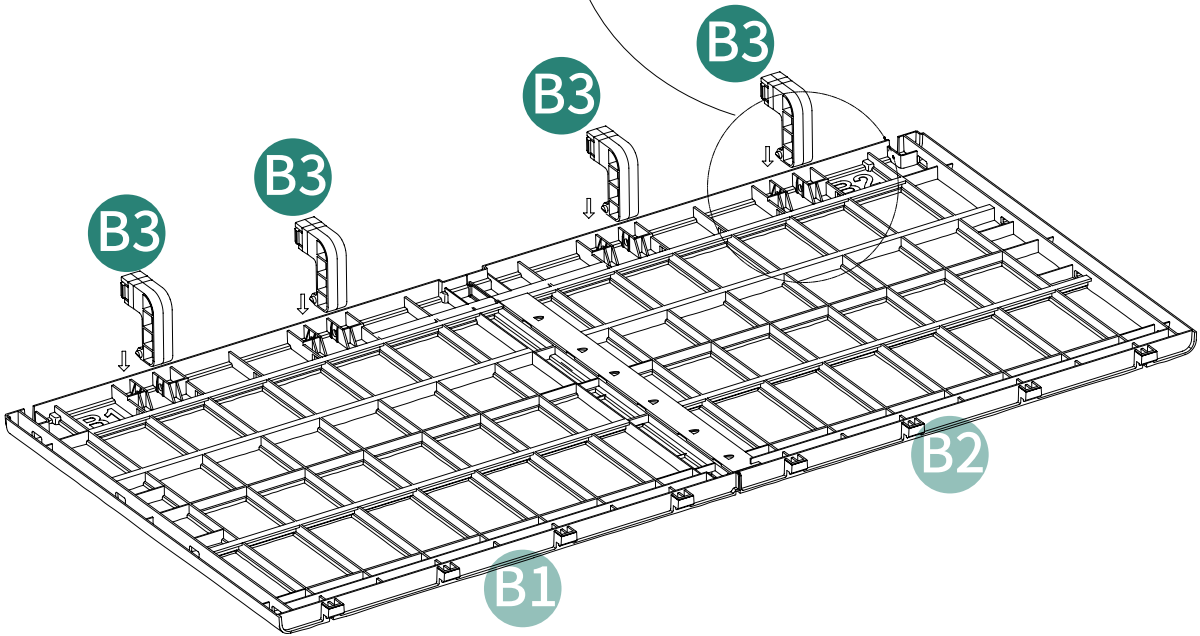
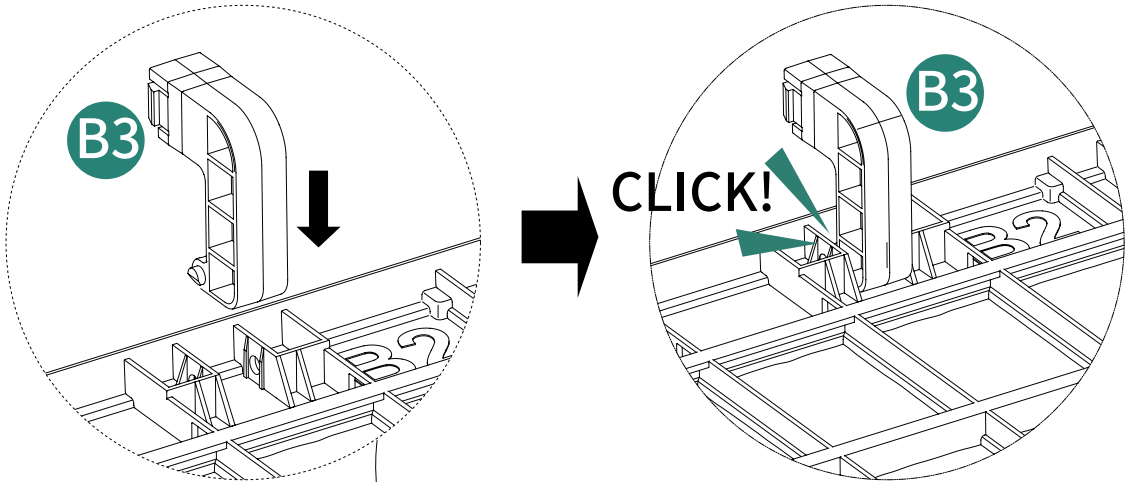

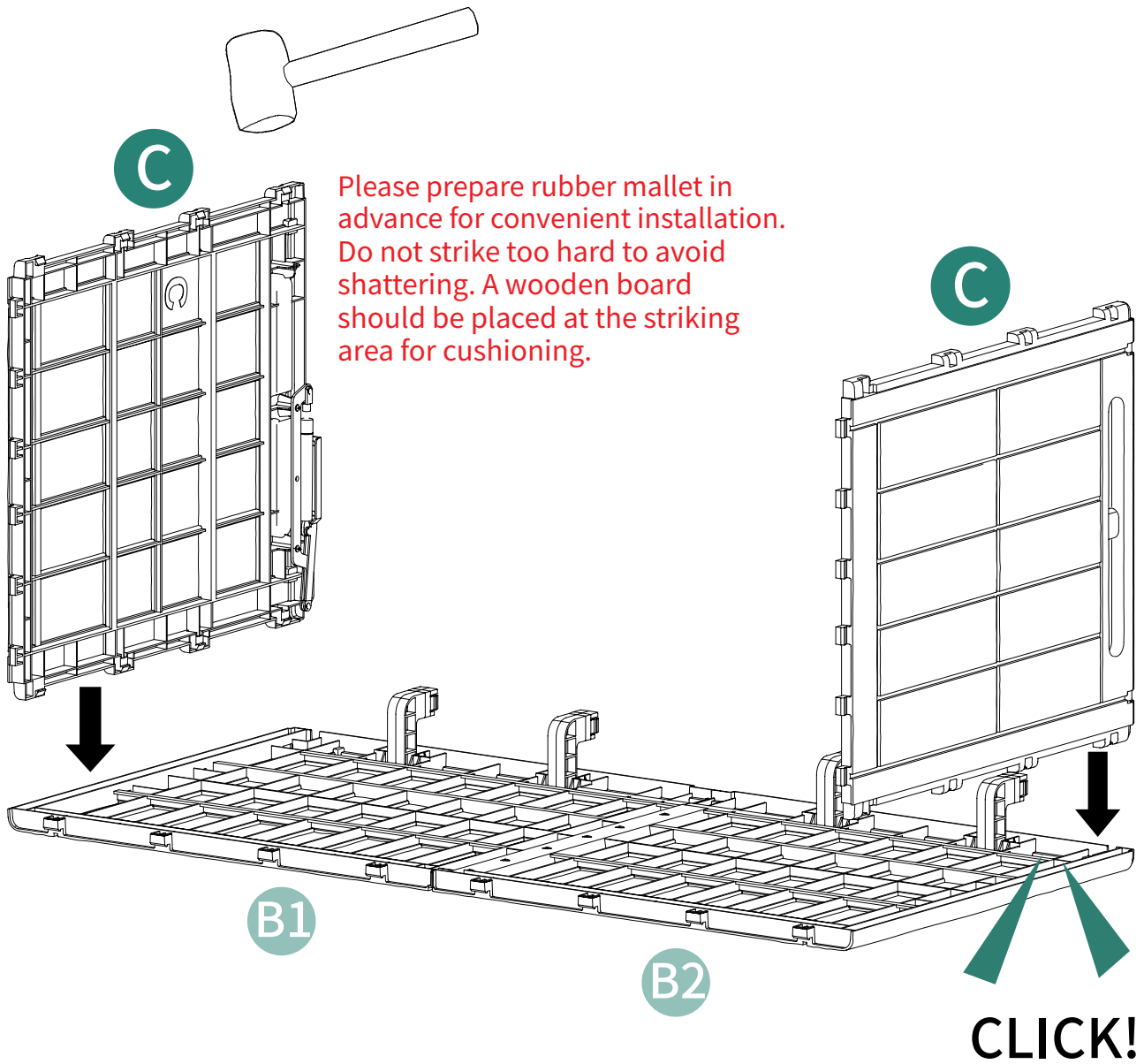
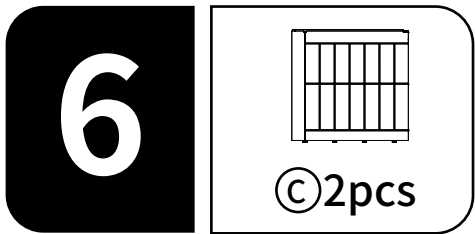

7

Please prepare rubber mallet in advance for convenient installation. Do not strike too hard to avoid shattering. A wooden board should be placed at the striking area for cushioning.

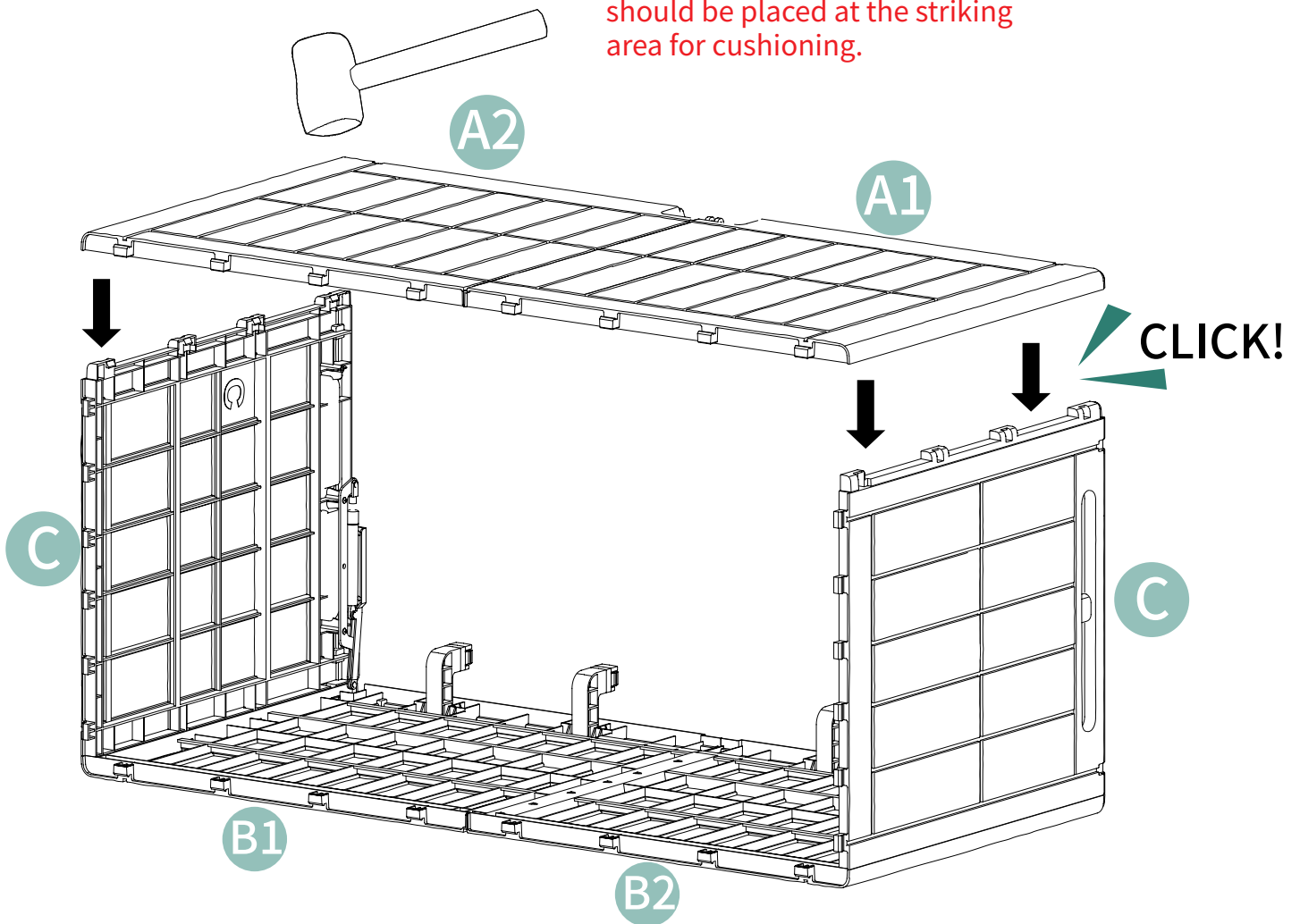

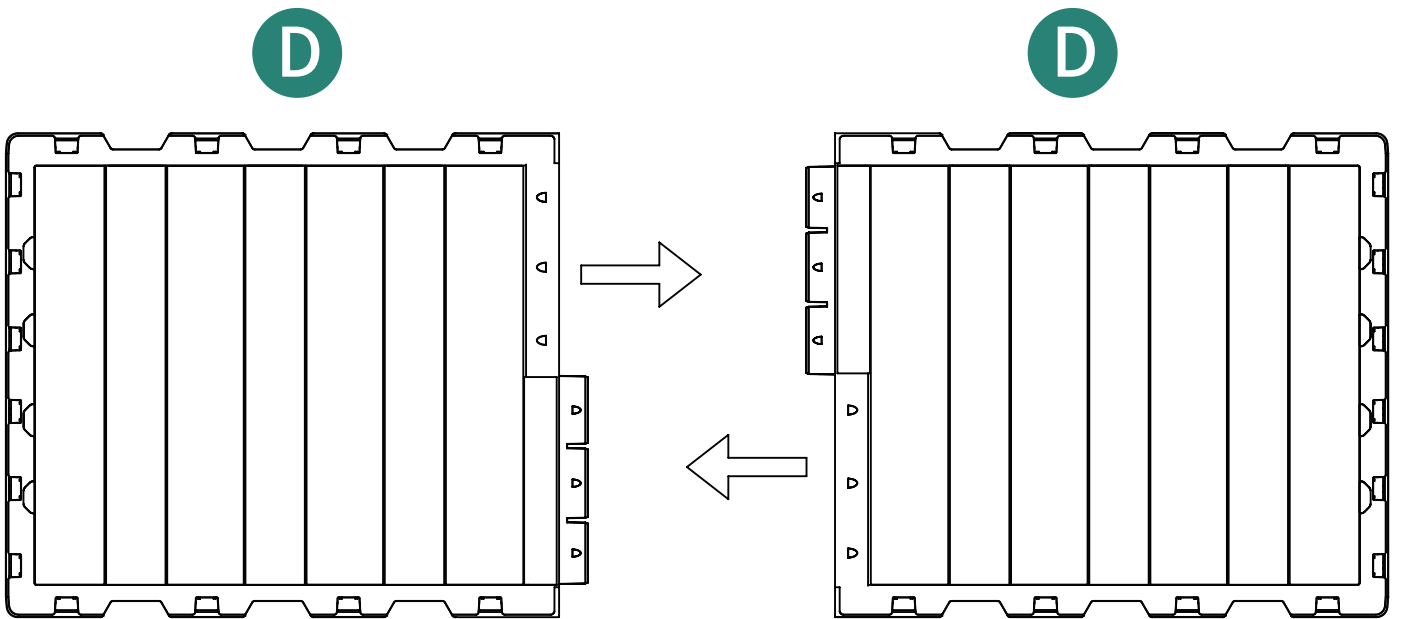
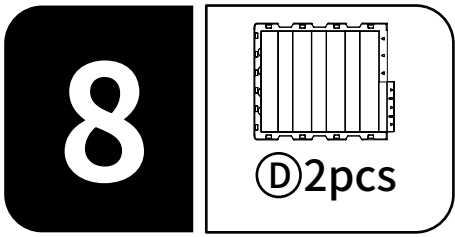

9

Please prepare rubber mallet in advance for convenient installation.
Do not strike too hard to avoid shattering. A wooden board should be placed at the striking area for cushioning.

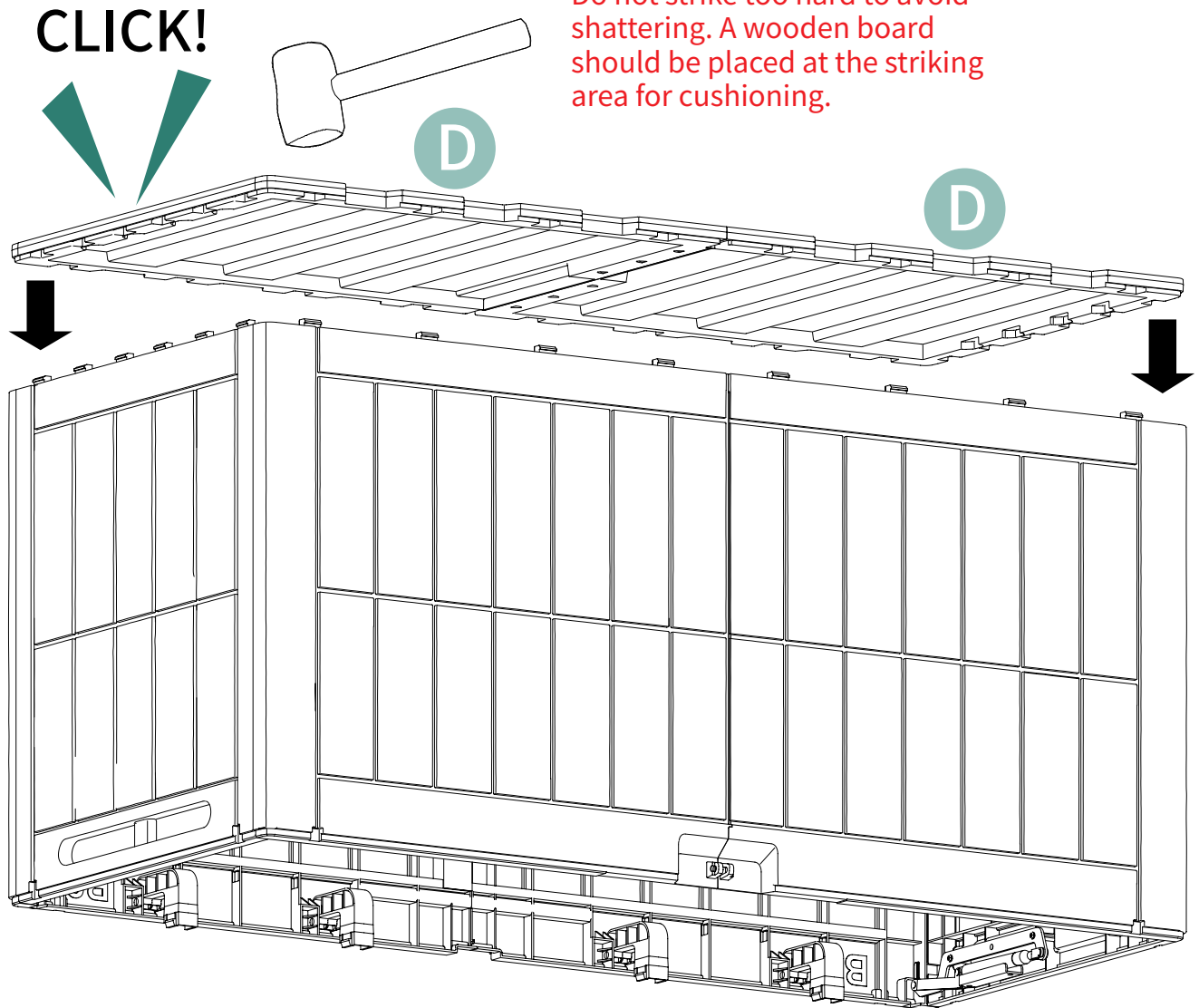

10

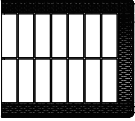

Ⓔ2 1pc

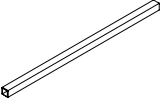

ⒺH 1pc

H



E2

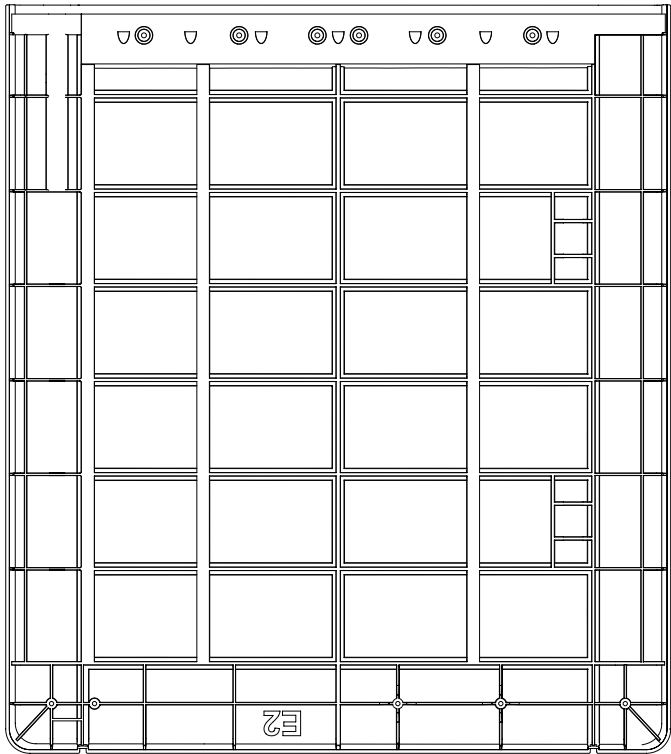

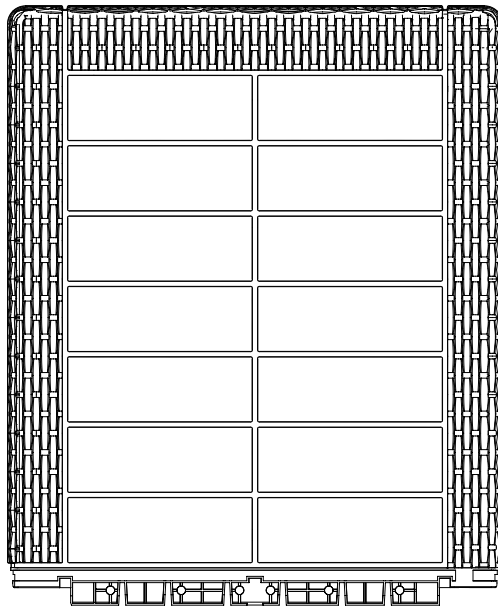
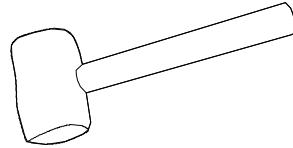
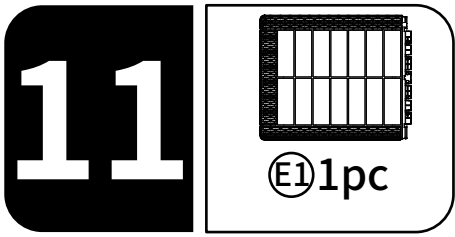

Please prepare rubber mallet in advance for convenient installation. Do not strike too hard to avoid shattering. A wooden board should be placed at the striking area for cushioning.

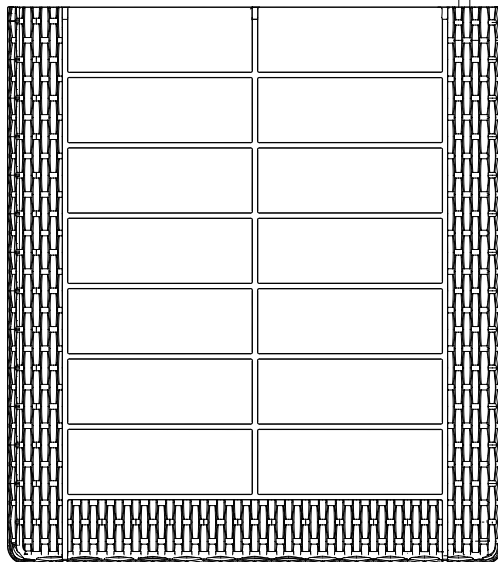
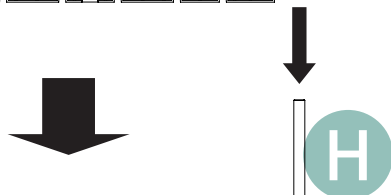

12



ⓐ 6pcs

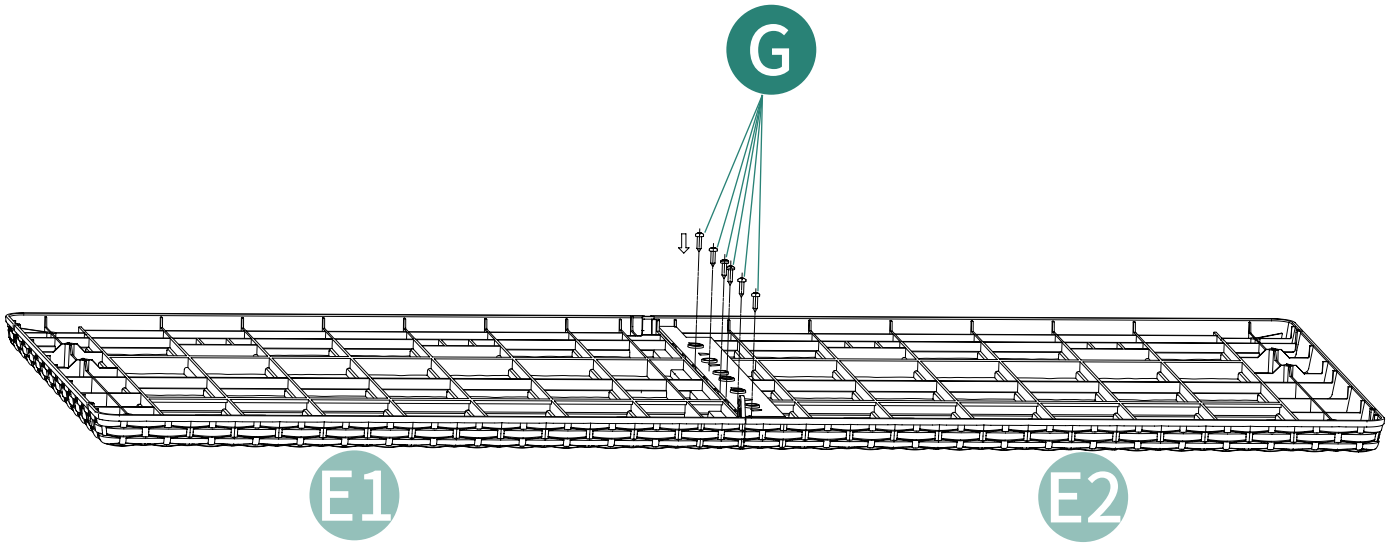

13

Connect the E plate with the clasp.

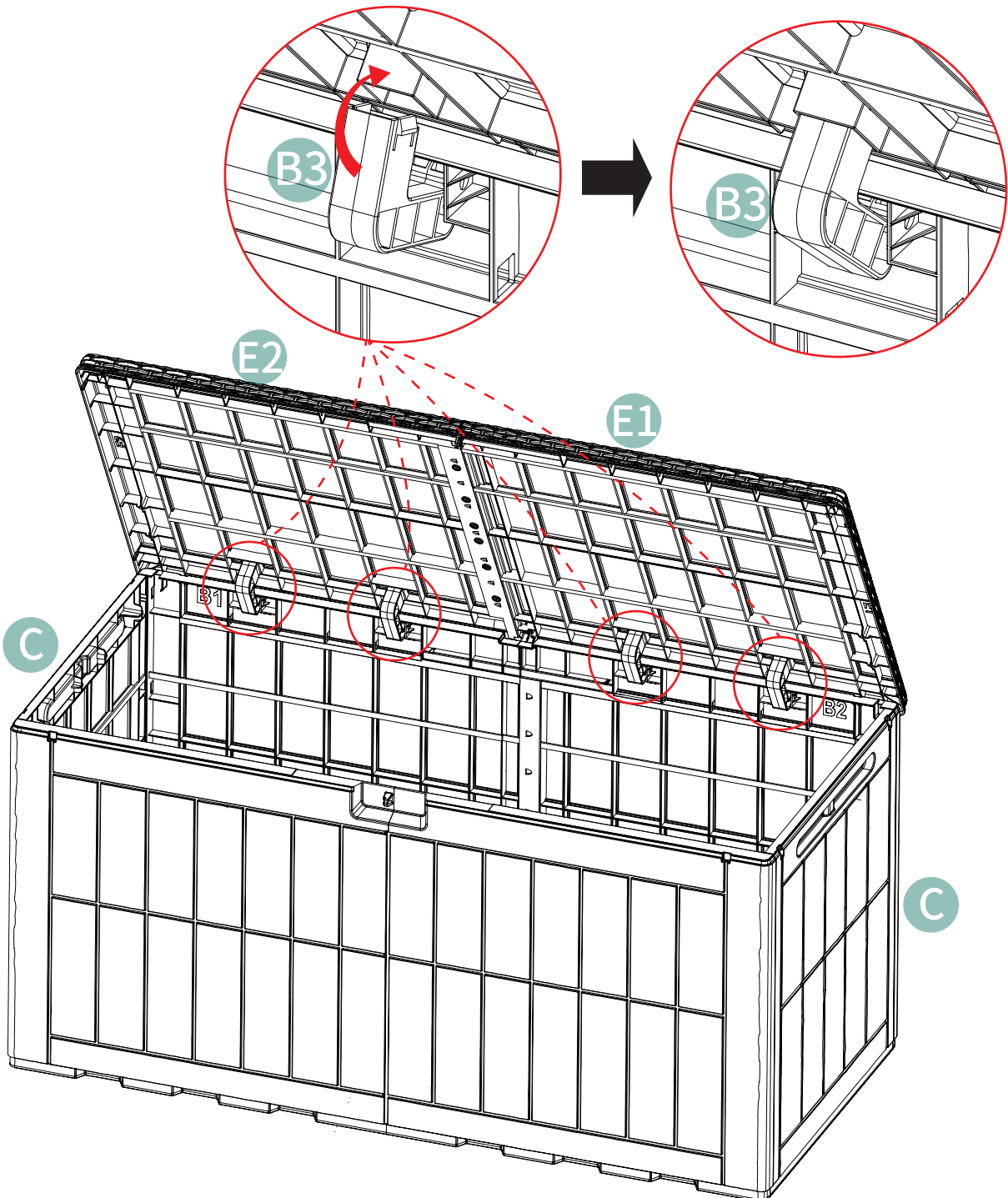

14

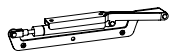

ⓕ 2pcs



ⓐ 8pcs

Secure the hydraulic gas strut with screws.

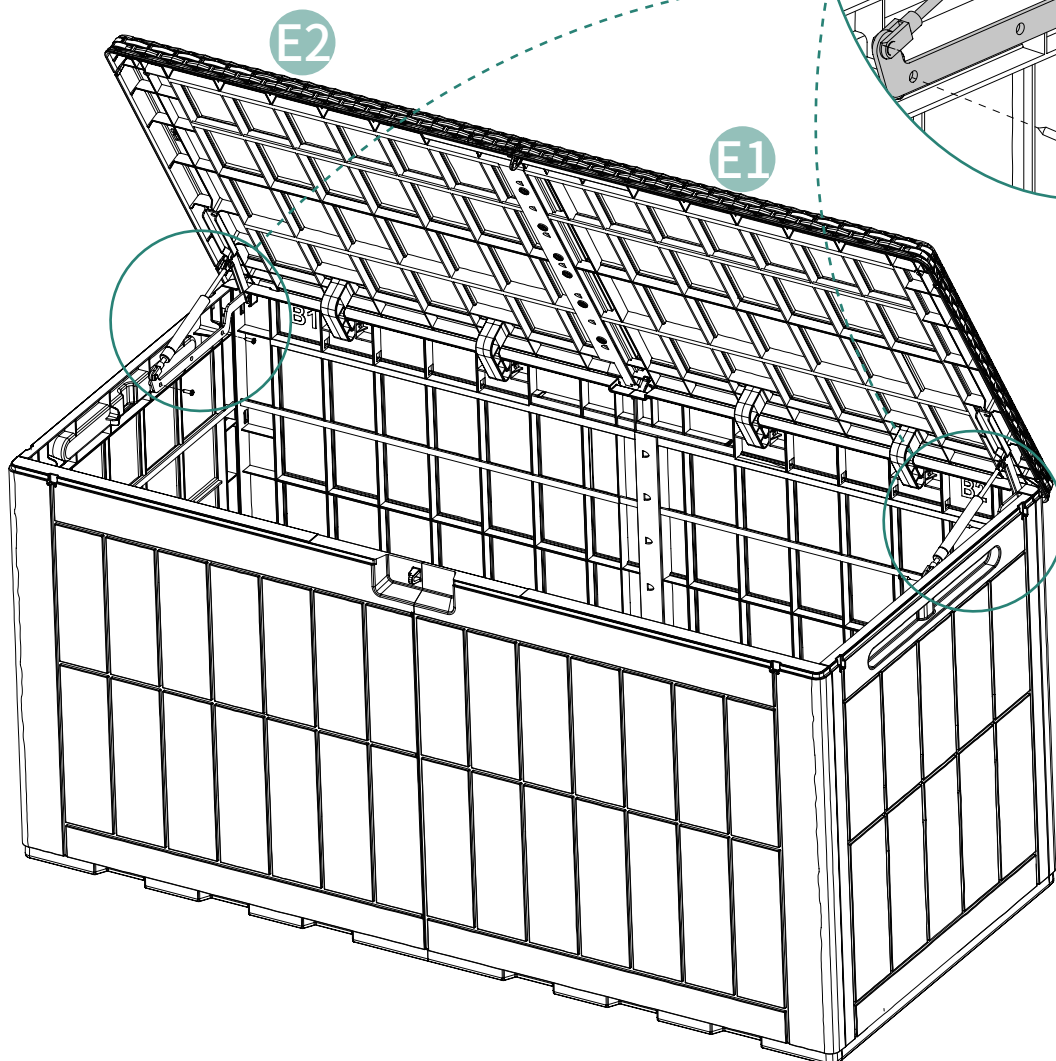
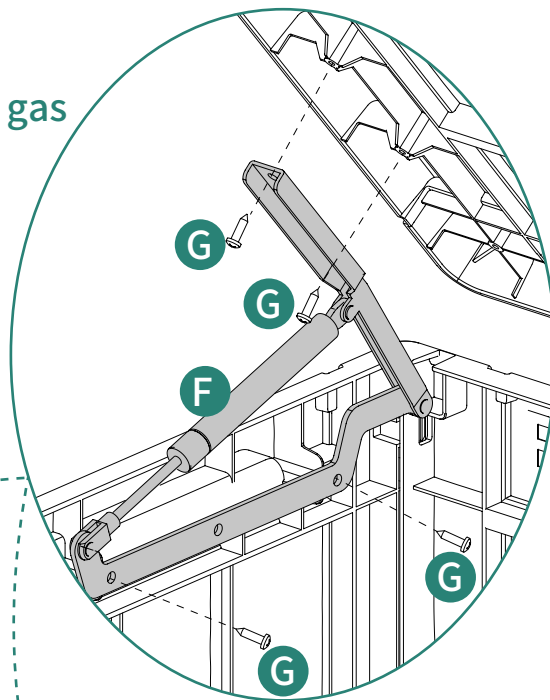

15



① 1pc

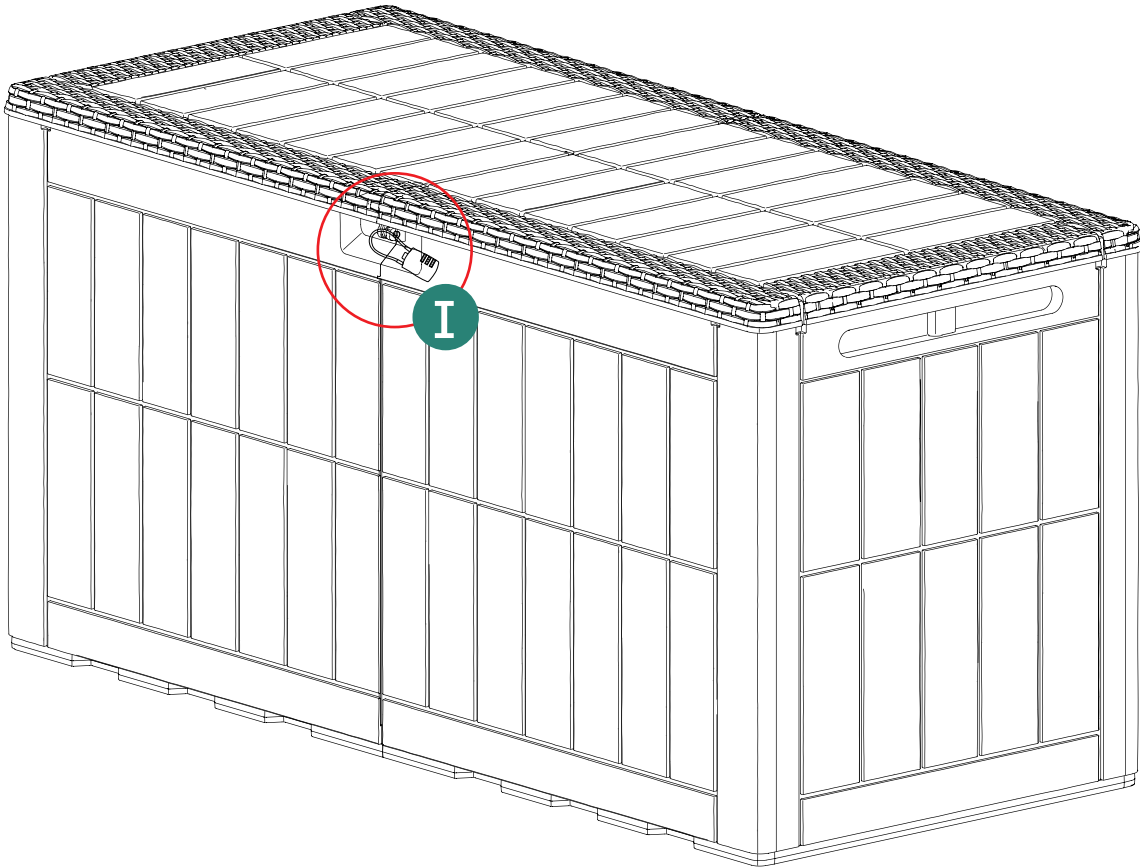

1. The initial password is 000. Align with the scale line of the lock body. Press the button on the top with your hand, and the locking beam will pop up, then you can open it.



2. Use metal to forcefully press against the code-adjusting hole at the bottom until it is in a sunken state, and don't release it.



3. Use metal to press against the lock-hole at the bottom while turning the numbers to set the password you need.



4. Just release the metal that is propping against the bottom, and then the operation will be completed.

Installation Completed

HELP CENTER



Inquiry



Assembly issue



Missing parts

If you encounter any difficulties during assembly, please contact us.

Wenn Sie während der Montage auf Schwierigkeiten stoßen, kontaktieren Sie uns bitte.

Si vous rencontrez des difficultés lors du montage, veuillez nous contacter.

Se incontri difficoltà durante il montaggio, ti preghiamo di contattarci.

Si encuentras alguna dificultad durante el ensamblaje, por favor contáctanos.

DISCLAIMER

Manufacturer and seller expressly disclaim any and all liability for personal injury, property damage or loss, whether direct, indirect, or incidental, resulting from the incorrect attachment, improper use, inadequate maintenance, unapproved modification, or neglect of this product.

Der Hersteller und Verkäufer lehnen ausdrücklich jegliche Haftung für Personenschäden, Sachschäden oder Verluste ab, egal ob direkt, indirekt oder zufällig, die durch falsche Anbringung, unsachgemäßen Gebrauch, unzureichende Wartung, nicht genehmigte Änderungen oder Vernachlässigung dieses Produkts entstehen.

El fabricante y vendedor renuncian expresamente a toda responsabilidad por lesiones personales, daños materiales o pérdidas, ya sean directos, indirectos o incidentales, derivados de la incorrecta colocación, uso inadecuado, mantenimiento insuficiente, modificación no aprobada o negligencia de este producto.

Il produttore e il venditore declinano espressamente ogni responsabilità per lesioni personali, danni materiali o perdite, dirette, indirette o incidentali, derivanti dall'errato fissaggio, uso improprio, manutenzione inadeguata, modifica non autorizzata o negligenza di questo prodotto.

Le fabricant et le vendeur déclinent expressément toute responsabilité en cas de blessures corporelles, de dommages matériels ou de pertes, qu'ils soient directs, indirects ou accessoires, résultant de la fixation incorrecte, de l'utilisation inappropriée, de l'entretien insuffisant, de la modification non approuvée ou de la négligence de ce produit.