

NOTICE

*Please make sure that you have all parts indicated and they are in good condition before you begin assembly of this item. Refer to part list and hardware list below for guidance.

*This item should be assembled on a soft surface to prevent scratching the finish during assembly.

*This item may require periodic tightening.

*If you are having difficulty, our friendly Customer Care team is always here to help.

PREPARATION

*Before beginning assembly of product, make sure all parts are present. Compare parts with part contents list and hardware contents list.

*If any part is missing or damaged, do not attempt to assemble the product.

*Estimated Assembly Time: 90 minutes.

*Tools Required for Assembly (included): Allen Key

CARE AND MAINTENANCE

Adhesive felt pads should always be applied to areas of furniture which make direct contact with flooring, said application will prevent damage to the furniture and or surfaces on which the furniture lies. Objects placed on articles of furniture should rest on non abrasive material as to prevent damage to the wood finish. Objects whose composition consists of plastic and rubber are known to discolor and damage the wood surfaces on which they rest. Wipe up spills immediately and avoid common hazards such as hot dishes, harsh solvents and abrasives. Cleaning should be done with a soft lint free cotton cloth dampened with water or furniture polish. On highly used surfaces we recommend applying a quality paste wax which should be used on a regular basis to provide additional protection from scratches and spills. How often you apply the wax depends on how much wear the furniture receives.

Part List

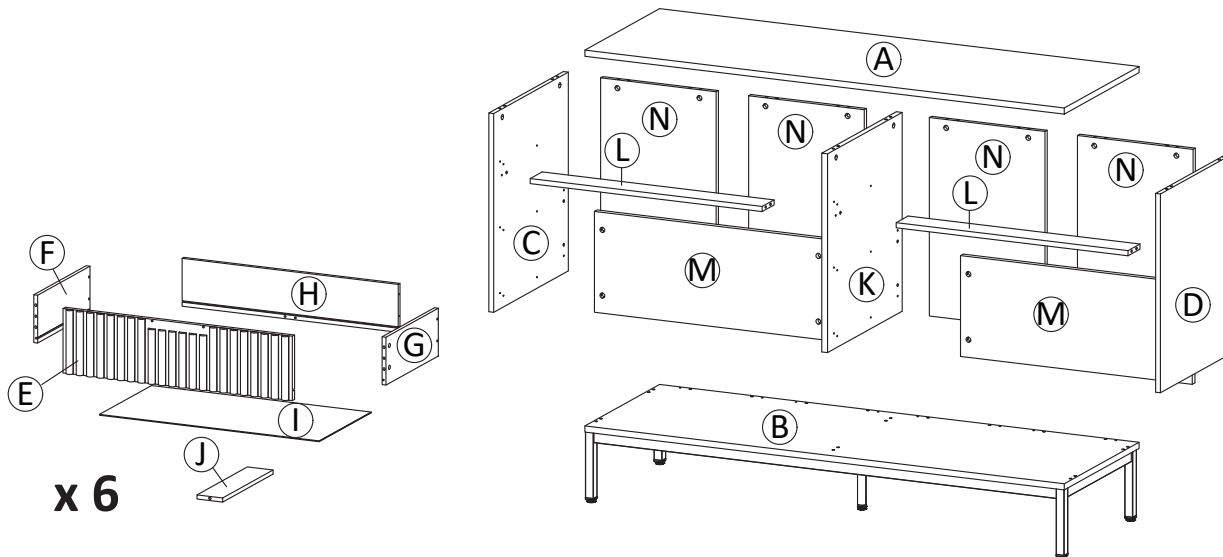

Product Dimensions: 58.86"Wx19.69"Dx32.42"H

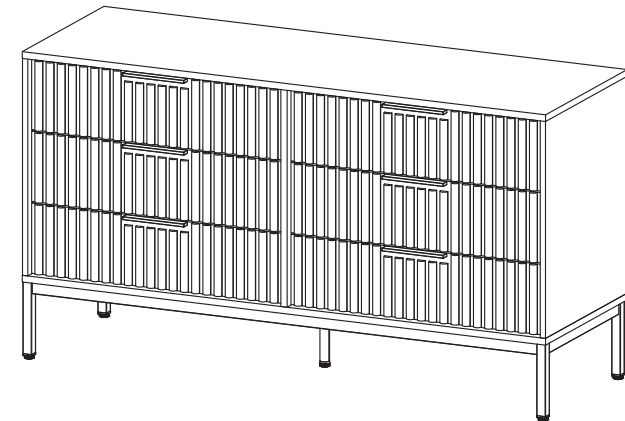

WARNING :











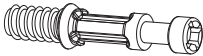



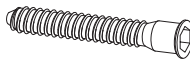

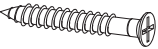



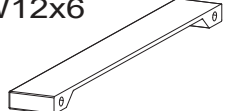

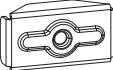
WEIGHT CAPACITY: 108 LBS.

DRAWER LOAD CAPACITY: 15 LBS

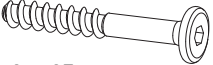
Warning : Do not stand on chest.

Warning : Do not over torque bolts.

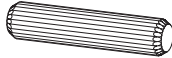
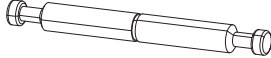
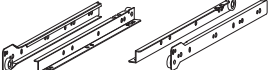
Hardware List

<p>HW1x50</p>  <p>Ø 6 x 35 mm</p>	<p>HW2x26</p>  <p>Ø 15 mm</p>	<p>HW3x34</p>  <p>Ø 8 x 30 mm</p>	<p>HW4x12</p>  <p>Ø 6 x 30 mm</p>	<p>HW5x14</p>  <p>M 7 x 50 mm</p>	<p>HW6x2</p> 
<p>HW7x30</p>  <p>Ø 12 mm</p>	<p>HW8x36</p>  <p>M 8 x 39 mm</p>	<p>HW9x4</p>  <p>M 4.5 x 12.5 mm</p>	<p>HW10x36</p>  <p>M 6 x 10.5 mm</p>	<p>HW11x36</p>  <p>M 3.5 x 13 mm</p>	<p>HW12x6</p> 
<p>HW13x12</p>  <p>M 4 x 22 mm</p>	<p>HW14x4</p> 	<p>HW15x4</p> 	<p>HW16x2</p> 	<p>HW17x2</p> 	<p>HW18x4</p>  <p>M 6 x 40 mm</p>
<p>HW19x14</p>  <p>M 6.4 x 45 mm</p>	<p>HW20x24</p> 	<p>HW21x24</p>  <p>M 3.5 x 15.5 mm</p>	<p>HW22x4</p> 	<p>HW23x3</p>  <p>Ø 8 x 50 mm</p>	<p>HW24x3</p> 
<p>HW RM35Ax6</p> 	<p>HW LM20A1x1</p> 				

Part List & HW For Multi-Box Items

Piece	Description	Qty	Carton Call
A	Top Board	1	1 of 2
B	Bottom Board	1	1 of 2
C	Side Board Left	1	2 of 2
D	Side Board Right	1	2 of 2
E	Front Drawer	6	2 of 2
F	Side Drawer Left	6	1 of 2
G	Side Drawer Right	6	2 of 2
H	Back Drawer	6	2 of 2
I	Bottom Drawer	6	2 of 2
J	Support Drawer	6	1 of 2
K	Center Board	1	1 of 2
L	Support Board 1	2	1 of 2
M	Support Board 2	2	2 of 2
N	Back Board	4	1 of 2

Piece	Description	Qty	Carton Call
HW1	Cambolt	50	2 of 2
HW2	CamLock Big	26	2 of 2
HW3	Dowel Ø8x30 mm	34	2 of 2
HW4	Dowel Ø6x30 mm	12	2 of 2
HW5	Screw M 7 x 50 mm	14	2 of 2
HW6	Allen Key	2	2 of 2
HW7	CamLock Small	30	2 of 2
HW8	Screw M 8 x 39 mm	36	1 of 2
HW9	Screw M 4.5 x 12.5 mm	4	1 of 2
HW10	Screw M 6 x 10.5 mm	36	2 of 2
HW11	Screw M 3.5 x 13 mm	36	2 of 2
HW12	Handle	6	2 of 2
HW13	Screw M 4 x 22 mm	12	2 of 2
HW14	Corner Brace	4	2 of 2
HW15	Support Corner Brace	4	2 of 2
HW16	Support Metal 1	2	2 of 2
HW17	Support Metal 2	2	2 of 2
HW18	Screw M 6 x 40 mm	4	2 of 2
HW19	Screw M 6.4 x 45 mm	14	2 of 2
HW20	Wedge	24	2 of 2
HW21	Screw M 3.5 x 15.5 mm	24	2 of 2
HW22	Leg	4	2 of 2
HW23	Dowel Ø8x50 mm	3	2 of 2
HW24	Double End Cambolt	3	2 of 2
HW RM35A	Drawer Runner	6	2 of 2
HW LM20A1	Center Leg	1	2 of 2

PREPARATION

*Before beginning assembly of product, make sure all parts are present. Compare parts with part contents list and hardware contents list.

*If any part is missing or damaged, do not attempt to assemble the product.

*Estimated Assembly Time: 90 minutes.

*Tools Required for Assembly (included): Allen Key

*If you are having difficulty, our friendly Customer Care team is always here to help.

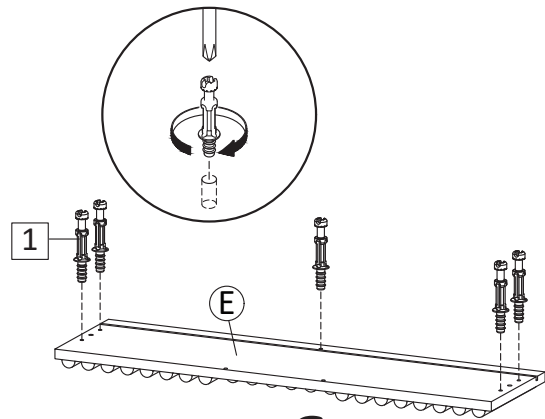

x 6

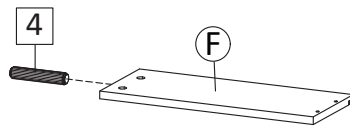

x 6

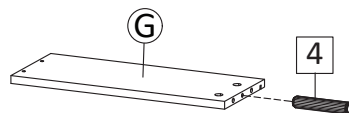

x 6

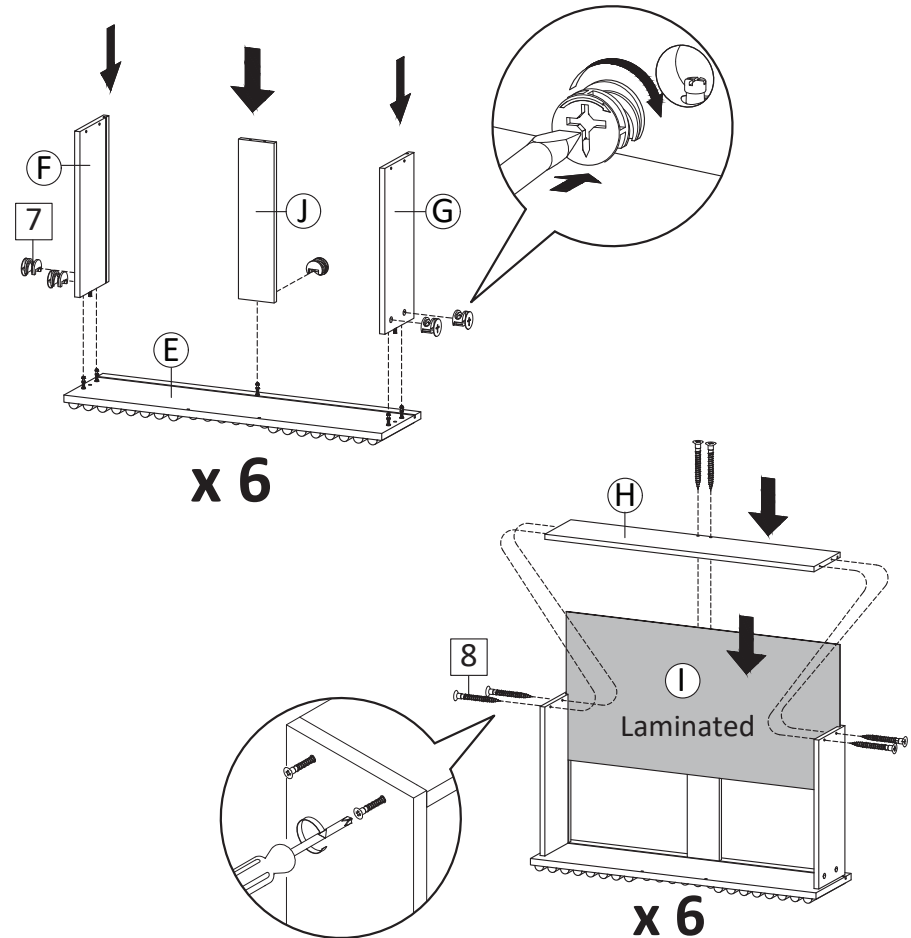

x 6

x 6

STEP1: Insert Cambolt (HW1) into Front Drawer (E). Insert Dowel $\text{\O}6 \times 30\text{mm}$ (HW4) into Side Drawers (F&G).

STEP2: Combine Side Drawers (F&G) and Support Drawer (J) into Front Drawer (E) then tighten Camlock Small (HW7) using screwdriver. Insert Bottom Drawer (I), then put Back Drawer (H) with laminated face facing upward then secure with Screw M8x39mm (HW8).

PREPARATION

- *Before beginning assembly of product, make sure all parts are present. Compare parts with part contents list and hardware contents list.
- *If any part is missing or damaged, do not attempt to assemble the product.
- *Estimated Assembly Time: 90 minutes.
- *Tools Required for Assembly (included): Allen Key
- *If you are having difficulty, our friendly Customer Care team is always here to help.

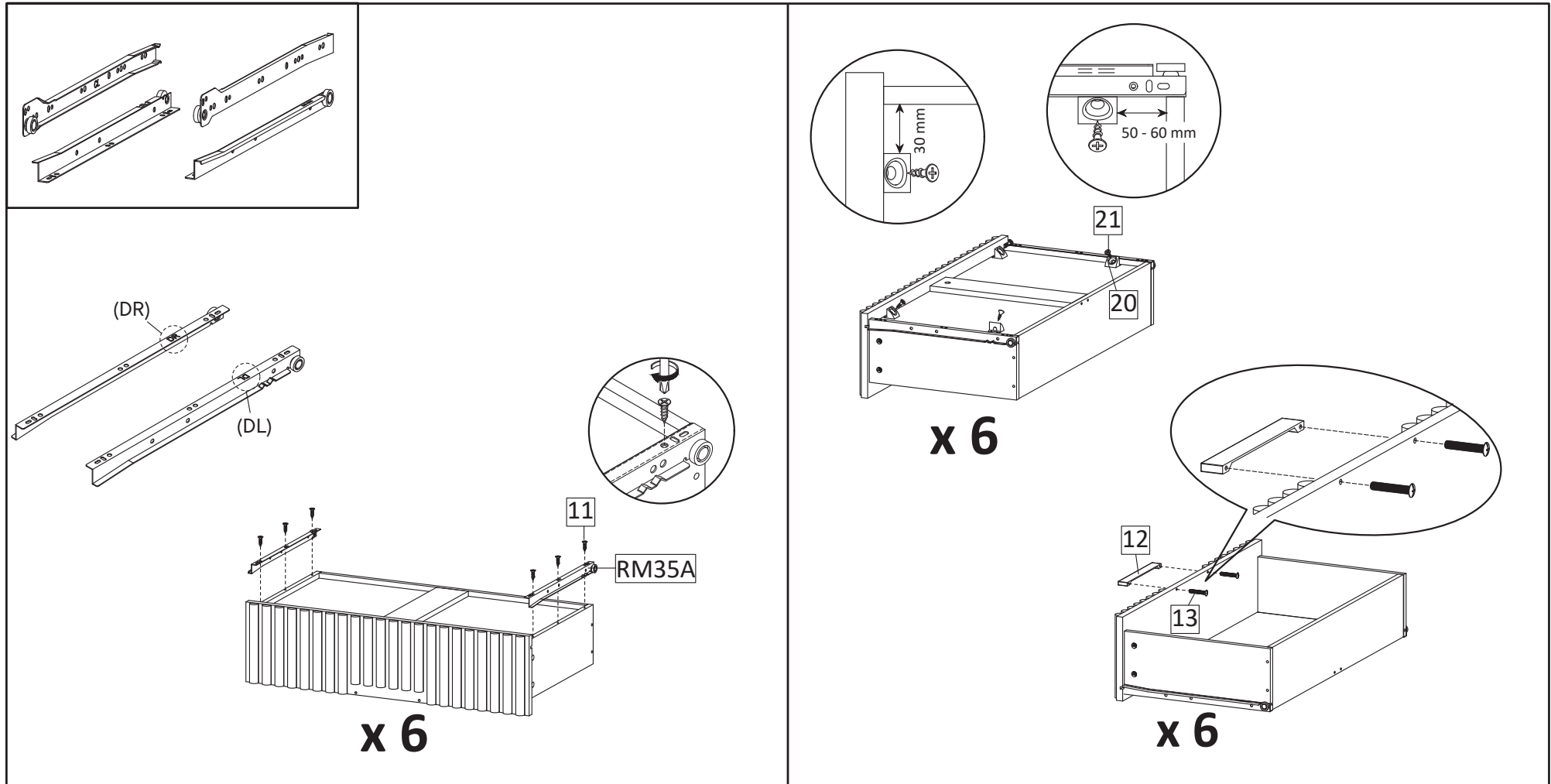

STEP3: Install the Drawer Runner (HW RM35A) into position as shown in picture. Secure with screws M3.5x13mm (HW11).

STEP4: Insert the Screw M3.5x15.5mm (HW21) and wedge (HW20) into the bottom of the drawer according to the picture. Use Screw M4x22mm (HW13) to attach Handle (HW12) to the Front Drawer.

PREPARATION

- *Before beginning assembly of product, make sure all parts are present. Compare parts with part contents list and hardware contents list.
- *If any part is missing or damaged, do not attempt to assemble the product.
- *Estimated Assembly Time: 90 minutes.
- *Tools Required for Assembly (included): Allen Key
- *If you are having difficulty, our friendly Customer Care team is always here to help.

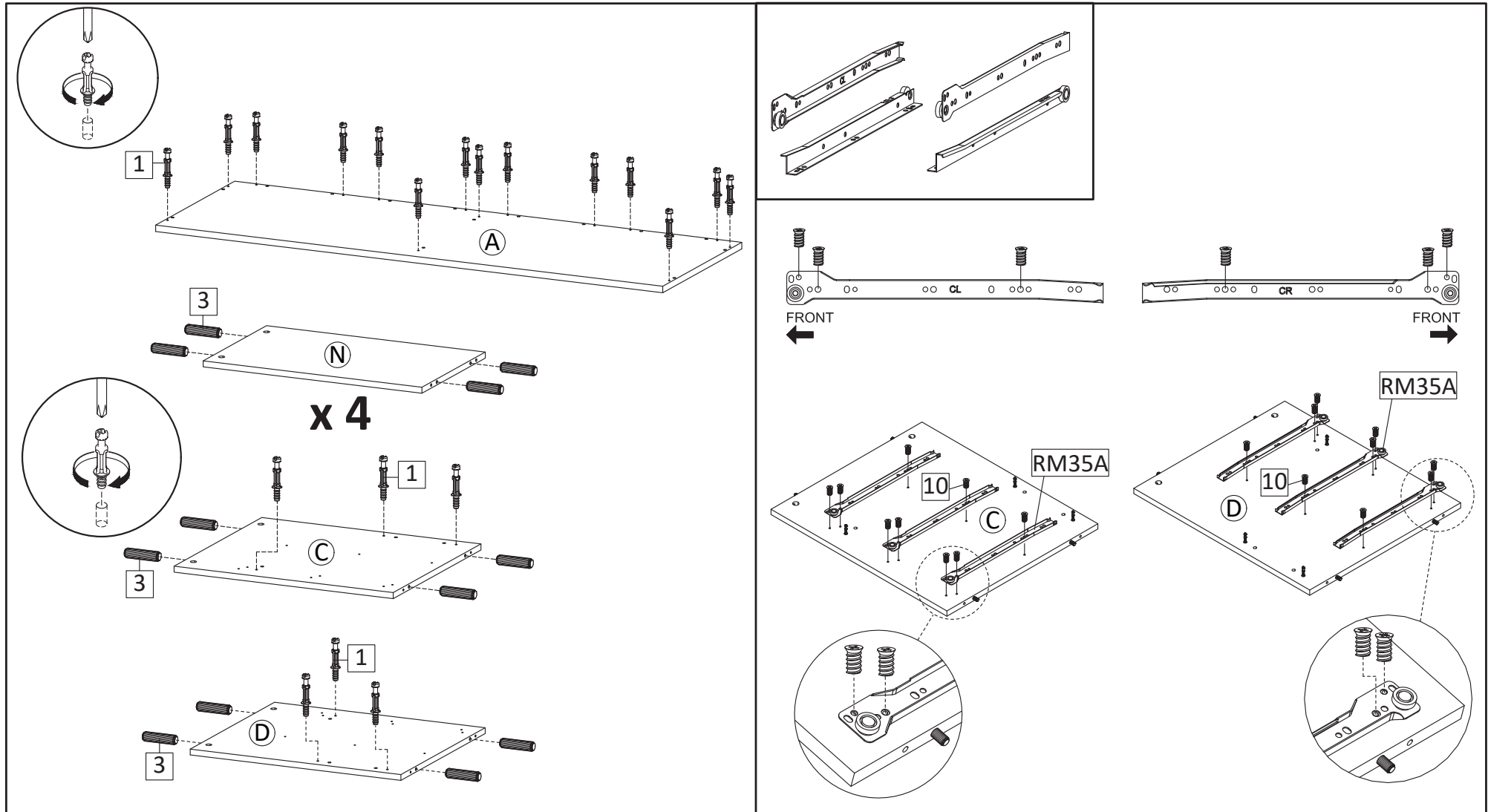

STEP5: Insert Cambolt (HW1) into Top Board (A), Side Board Left (C) and Side Board Right (D) according to the picture. Insert Dowel $\varnothing 8 \times 30 \text{mm}$ (HW3) into Side Board Left (C), Side Board Right (D) and Back Board (N).

STEP6: Insert Screw M6x10.5mm (HW10) into Side Board Left (C), Side Board Right (D) with securing part of the Drawer Runner (HW RM35A) into position as the above image.

PREPARATION

- *Before beginning assembly of product, make sure all parts are present. Compare parts with part contents list and hardware contents list.
- *If any part is missing or damaged, do not attempt to assemble the product.
- *Estimated Assembly Time: 90 minutes.
- *Tools Required for Assembly (included): Allen Key
- *If you are having difficulty, our friendly Customer Care team is always here to help.

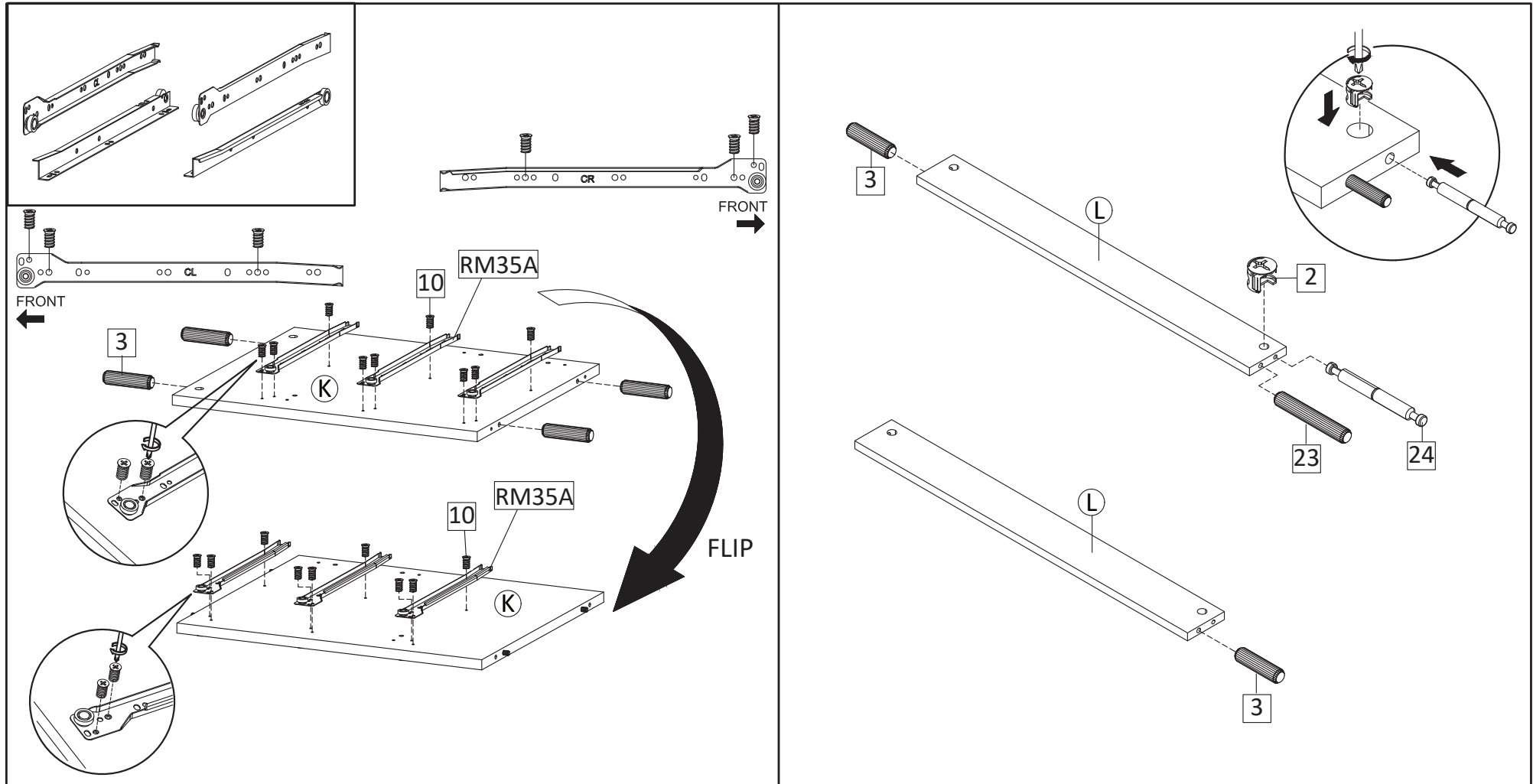

STEP7: Insert Dowel $\text{\O}8 \times 30 \text{mm}$ (HW3) into Center Board (K). Continue with securing part of the Drawer Runner (HW RM35A), into position as the above image, using screw M6x10.5mm (HW10). Please notice position the Drawer Runner part as per provided images. Flip the Center Board (K) to the other side then repeat the process.

STEP8: Insert Dowel $\text{\O}8 \times 30 \text{mm}$ (HW3) and Dowel $\text{\O}8 \times 50 \text{mm}$ (HW23) into Support Board 1 (L) into position as the above image. Insert Double End Cambolt (HW24) Secure with Camlock Big (HW2) and tighten it using screwdriver as figure.

PREPARATION

- *Before beginning assembly of product, make sure all parts are present. Compare parts with part contents list and hardware contents list.
- *If any part is missing or damaged, do not attempt to assemble the product.
- *Estimated Assembly Time: 90 minutes.
- *Tools Required for Assembly (included): Allen Key
- *If you are having difficulty, our friendly Customer Care team is always here to help.

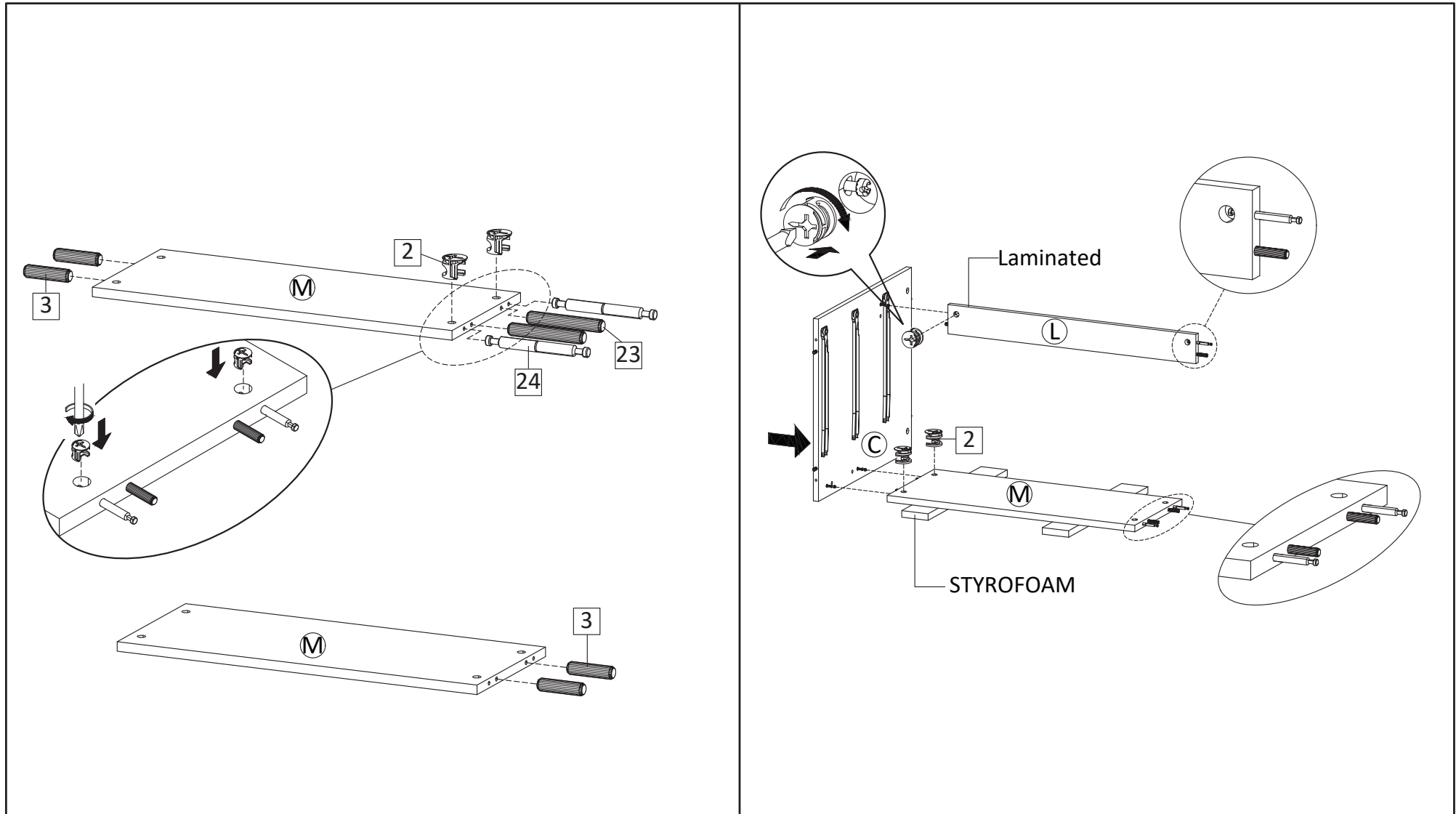

STEP9: Insert Dowel $\varnothing 8 \times 30 \text{mm}$ (HW3) and Dowel $\varnothing 8 \times 50 \text{mm}$ (HW23) into Support Board 2 (M) into position as the above image. Insert Double End Cambolt (HW24) Secure with Camlock Big (HW2) and tighten it using screwdriver as figure.

STEP10: Attach Support Board 1 (L) and Support Board 2 (M) into Side Board Left (C), Secure with Camlock Big (HW2) and tighten it using screwdriver as figure.

PREPARATION

- *Before beginning assembly of product, make sure all parts are present. Compare parts with part contents list and hardware contents list.
- *If any part is missing or damaged, do not attempt to assemble the product.
- *Estimated Assembly Time: 90 minutes.
- *Tools Required for Assembly (included): Allen Key
- *If you are having difficulty, our friendly Customer Care team is always here to help.

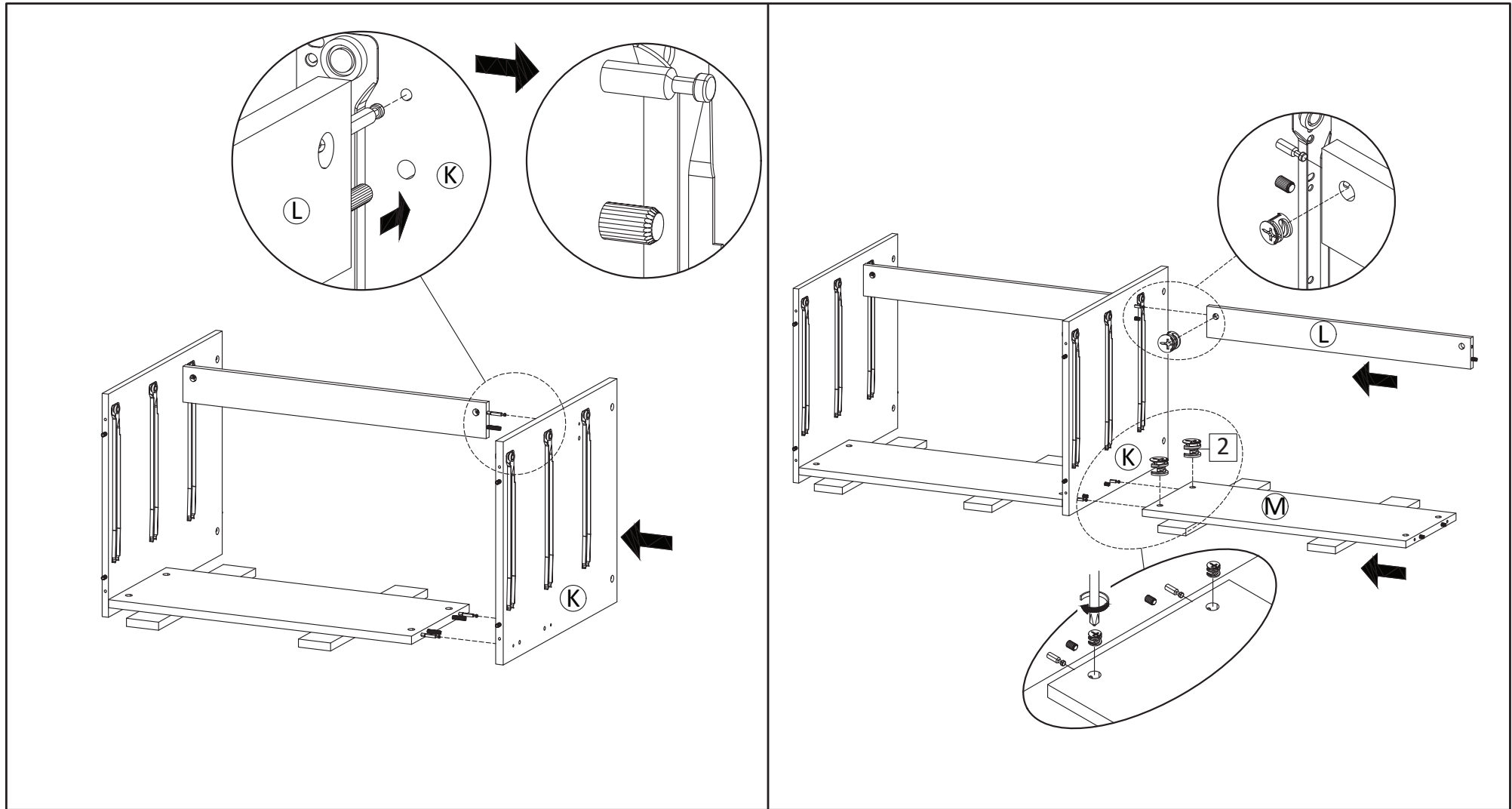

STEP11: Attach Center Board (K) as figure.

STEP12: Attach Support Board 1 (L) and Support Board 2 (M) into Center Board (K), Secure with Camlock Big (HW2) and tighten it using screwdriver as figure.

PREPARATION

- *Before beginning assembly of product, make sure all parts are present. Compare parts with part contents list and hardware contents list.
- *If any part is missing or damaged, do not attempt to assemble the product.
- *Estimated Assembly Time: 90 minutes.
- *Tools Required for Assembly (included): Allen Key
- *If you are having difficulty, our friendly Customer Care team is always here to help.

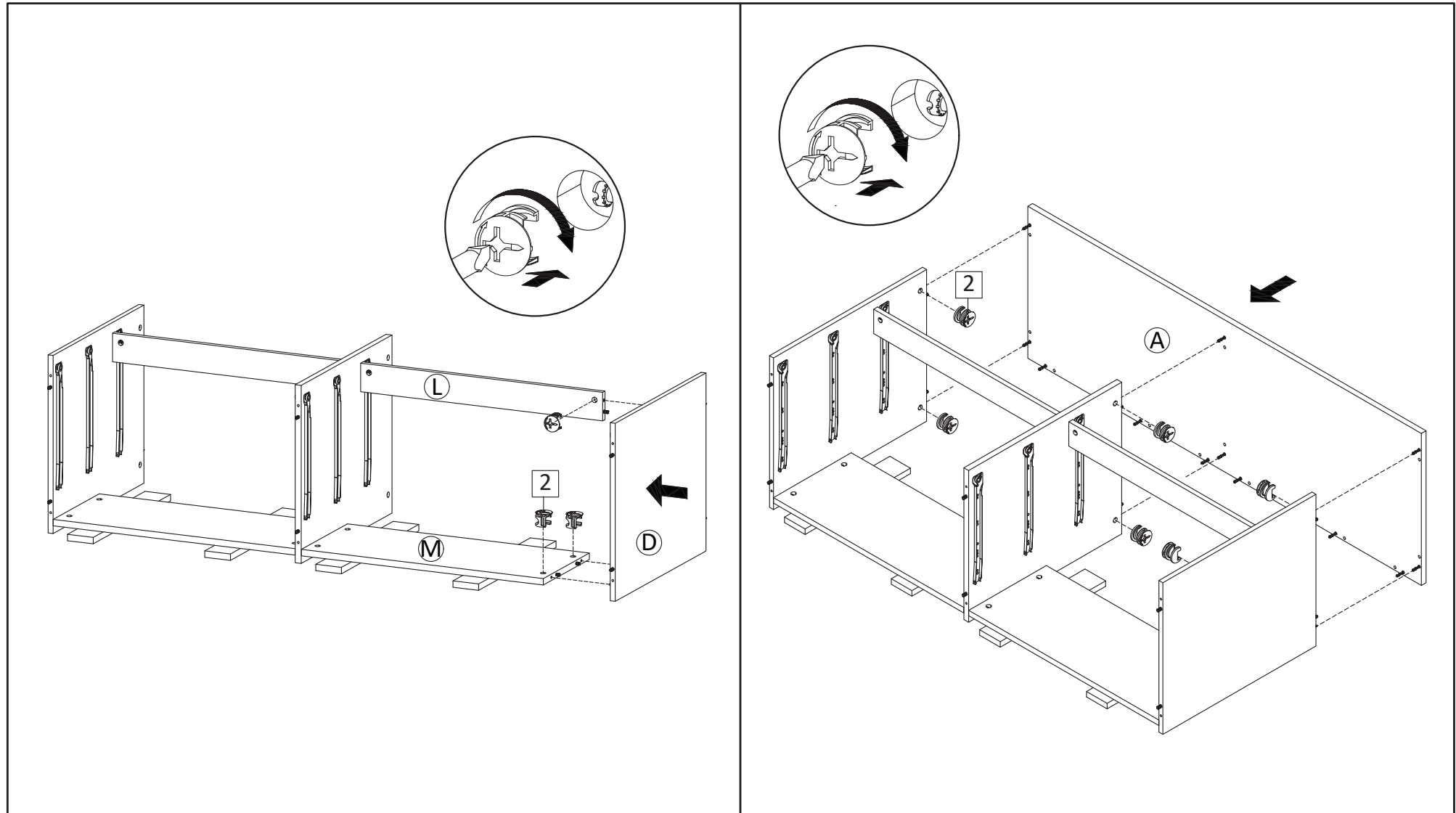

STEP13: Attach Side Board Right (D). Secure with Camlock Big (HW2) and tighten it using screwdriver as figure.

STEP14: Attach the Top Board (A) to the Body assembly Secure with Camlock Big (HW2) and tighten it using screwdriver as figure

PREPARATION

- *Before beginning assembly of product, make sure all parts are present. Compare parts with part contents list and hardware contents list.
- *If any part is missing or damaged, do not attempt to assemble the product.
- *Estimated Assembly Time: 90 minutes.
- *Tools Required for Assembly (included): Allen Key
- *If you are having difficulty, our friendly Customer Care team is always here to help.

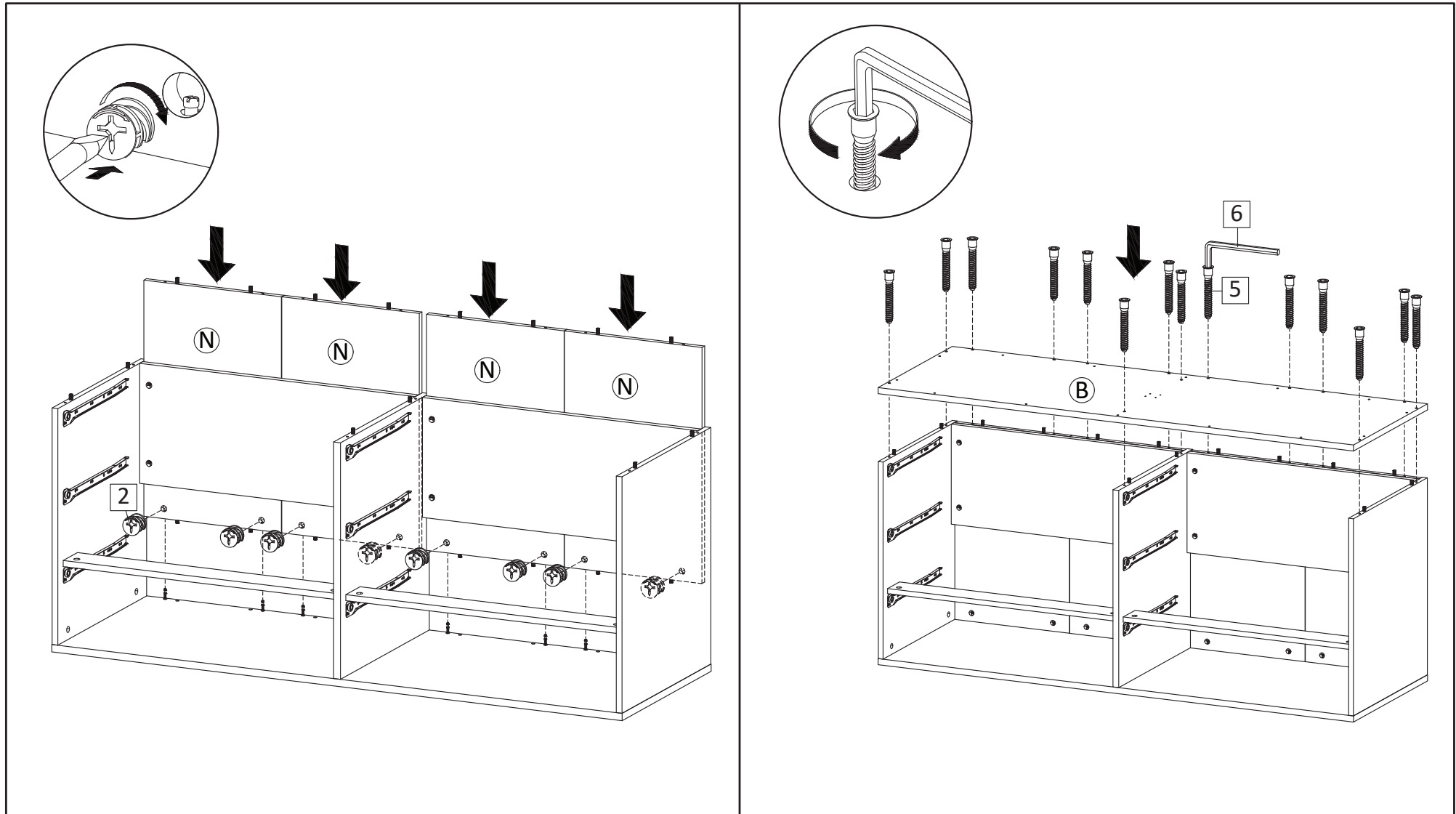

STEP15: Attach the Back Board (N) into Top Board (A) Secure with Camlock Big (HW2) and tighten it using screwdriver as figure.

STEP16: Place Bottom Board (B), then secure with Screw M7x50mm (HW5),tighten screws using Allen Key (HW6).

PREPARATION

- *Before beginning assembly of product, make sure all parts are present. Compare parts with part contents list and hardware contents list.
- *If any part is missing or damaged, do not attempt to assemble the product.
- *Estimated Assembly Time: 90 minutes.
- *Tools Required for Assembly (included): Allen Key
- *If you are having difficulty, our friendly Customer Care team is always here to help.

STEP17: Insert Support Corner Brace (HW15) and place it inside Leg (HW22) tube. Insert Screw (HW18) into the hole of Corner Brace (HW14). Screw in slightly just enough to grip Leg (HW22) with Support Corner Brace (HW15) inside. Do not tighten. Arrange Support Metal Leg 1 (HW16) & Support Metal Leg 2 (HW17) on the floor as per image.

STEP18: Install the prepared Leg (HW22). Ensure the Corner Brace (HW14) hooks onto the hole of Support Metal Leg 1 (HW16) and Support Metal Leg 2 (HW17). Screw in just enough to grip the support metal leg using Allen Key (HW6). Do not fully tighten. Repeat for the other legs.

PREPARATION

- *Before beginning assembly of product, make sure all parts are present. Compare parts with part contents list and hardware contents list.
- *If any part is missing or damaged, do not attempt to assemble the product.
- *Estimated Assembly Time: 90 minutes.
- *Tools Required for Assembly (included): Allen Key
- *If you are having difficulty, our friendly Customer Care team is always here to help.

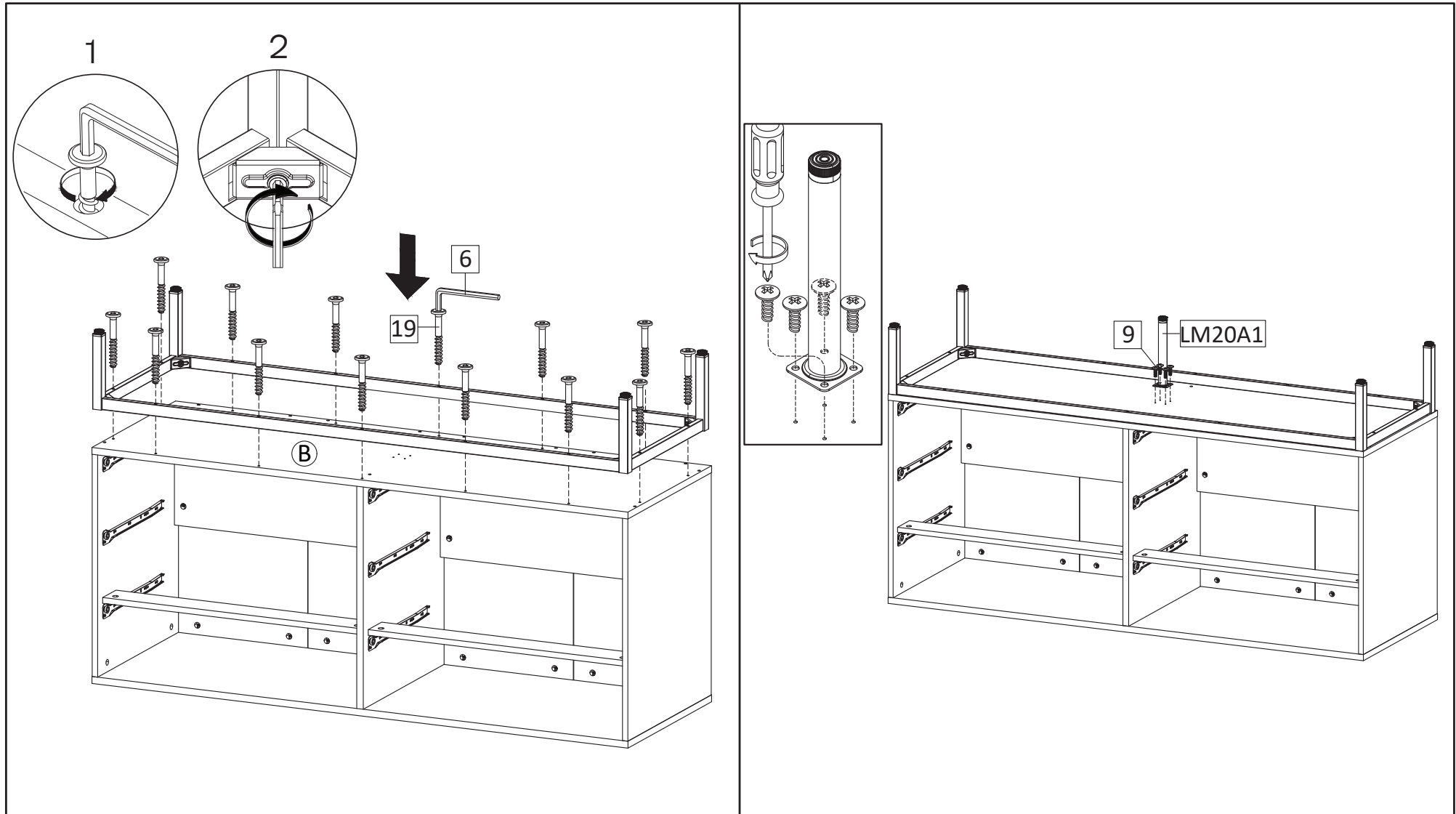

STEP19: Install the assembled leg unit from Step 18 onto the Bottom Board (B) by inserting Screw M6.4x45mm (HW19). Then, tighten all the screws on all corner braces (HW14) and Screws on Support Metal Leg 1 (HW16) & Support Metal Leg 2 (HW17) using an Allen Key (HW6).

STEP20: Install Center Leg (HW LM20A1), secure with Screw M4.5x12.5mm (HW9) into Bottom Board as figure.

PREPARATION

- *Before beginning assembly of product, make sure all parts are present. Compare parts with part contents list and hardware contents list.
- *If any part is missing or damaged, do not attempt to assemble the product.
- *Estimated Assembly Time: 90 minutes.
- *Tools Required for Assembly (included): Allen Key
- *If you are having difficulty, our friendly Customer Care team is always here to help.

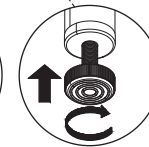
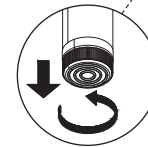
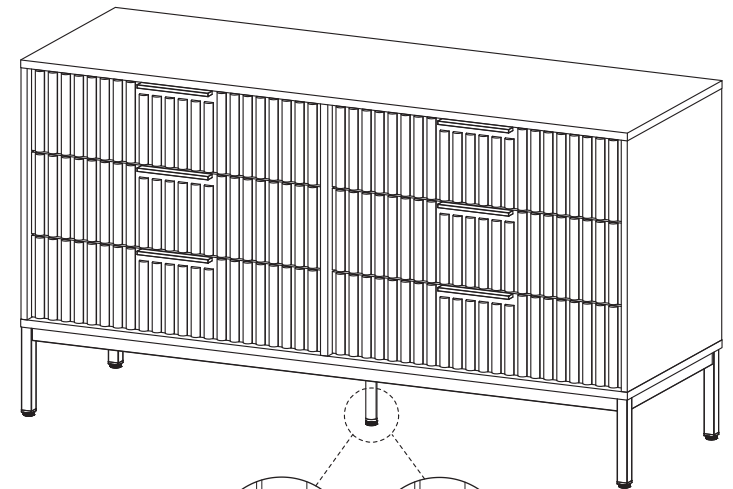
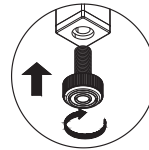
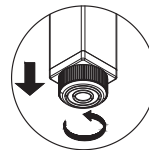
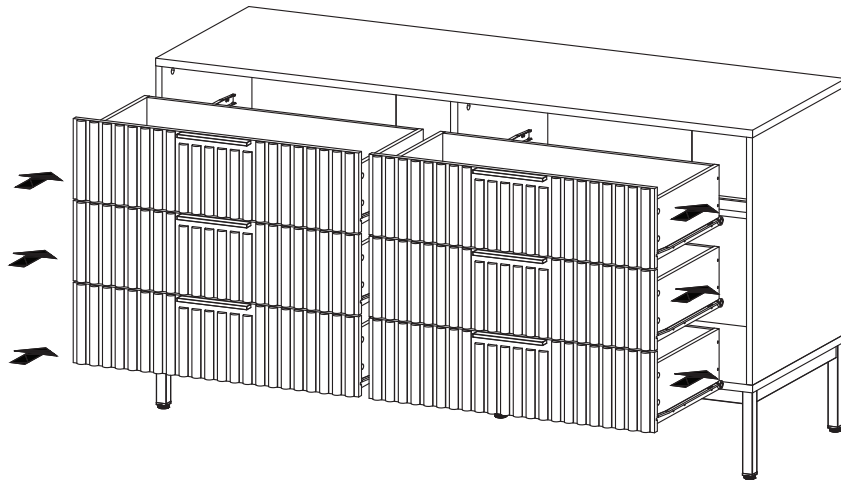
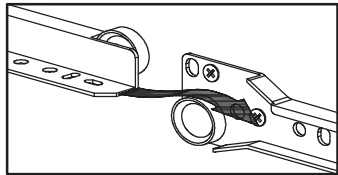

STEP21: Hold the sides of drawer, position the wheel of rail at drawer back and the wheel of rail at side boards and center board, according to the image. Slide in the drawers one by one into the Sideboard.

STEP22: Place your furniture on level floor. The legs come with adjustable leveller, adjust it as needed until your furniture sit steady on the floor. Assembly is complete.

TIPPING RESTRAINTS KIT INSTALLATION GUIDANCE

Different wall materials require unique wall fasteners.

The wall plugs (AA2) and screws (AA3) are designed for fixing to concrete walls only.

Please consult your local hardware store to ensure you are using the correct hardware for your wall type.

