

# ASSEMBLY INSTRUCTION

## DINING CHAIR

- |                     |                       |                     |                              |
|---------------------|-----------------------|---------------------|------------------------------|
| <b>A</b> Chair Back | <b>B</b> Seat Cushion | <b>C</b> Front Legs | <b>D</b> Bolts<br>Ø1/4"x75mm |
|---------------------|-----------------------|---------------------|------------------------------|

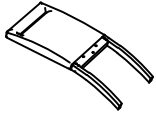

1pc

1pc

2pcs

4pcs

- |                              |                                 |                                     |                                     |
|------------------------------|---------------------------------|-------------------------------------|-------------------------------------|
| <b>E</b> Bolts<br>Ø1/4"x40mm | <b>F</b> Hex Nut<br>Ø5/16"x12mm | <b>G</b> Flat Washer<br>Ø5/16"x19mm | <b>H</b> Lock Washer<br>Ø5/16"x13mm |
|------------------------------|---------------------------------|-------------------------------------|-------------------------------------|



3pcs

4pcs

11pcs

11pcs

- |                           |                         |
|---------------------------|-------------------------|
| <b>I</b> Allen Key<br>4mm | <b>J</b> Wrench<br>12mm |
|---------------------------|-------------------------|

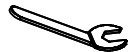

1pc

1pc

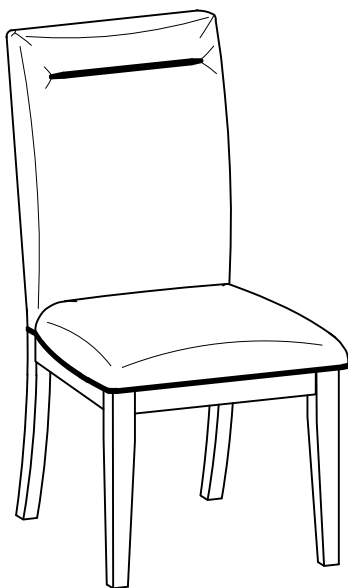

This page lists all the contents included in the box. Please take the time to identify the hardware as well as the individual components to this product. As you unpack and prepare for assembly, place the contents on a carpeted or padded area to protect them from damage.

- 1** Attach the Front Leg (C) to Seat Cushion (B) using Flat Washer (G), Lock Washer (H) and Hex Nut (F) by Wrench (J). Do not fully tighten.

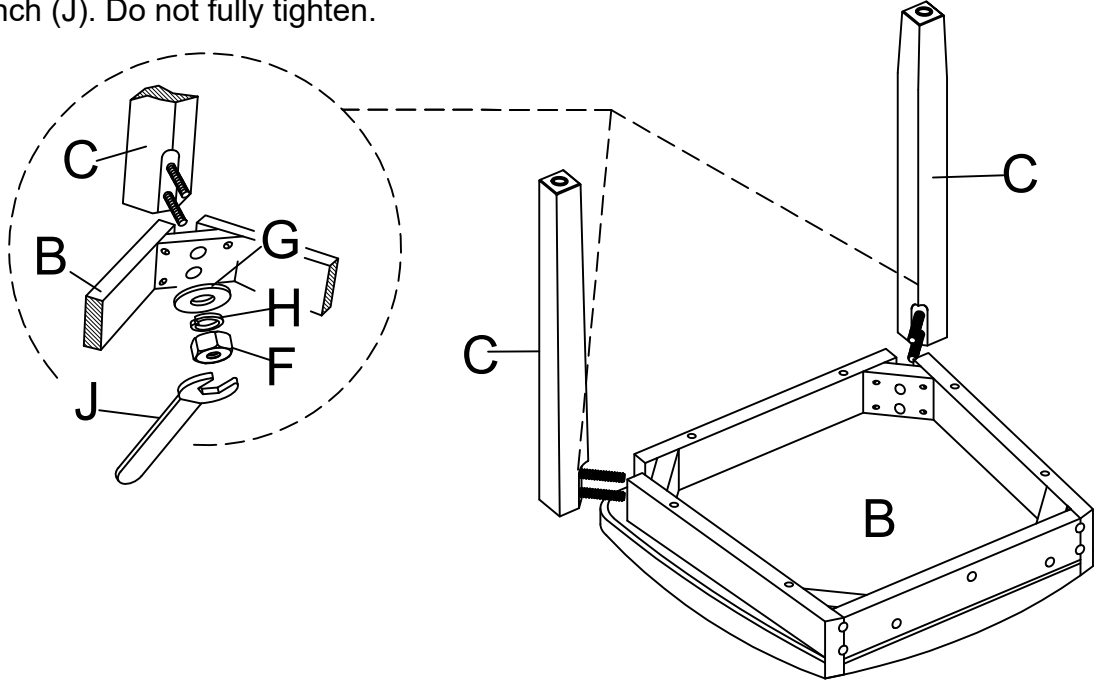

Take the Wrench, and turn the bolts until the legs are secure.  
**DO NOT TIGHTEN COMPLETELY.**  
 Stop when you feel you are adding force to tighten the bolt.

- 2** Attach Seat Cushion (B) to Chair Back (A) by securing the Flat Washer (G), Lock Washer (H) and Bolt (D) on corner. Flat Washer (G), Lock Washer (H) and Bolt (E) onto back rail and tighten with Allen Key (I). Hand tighten only at this moment by using Allen Key (I).

Stand chair up on an even surface and check that it is balanced. If there is a slight wobble, apply downward pressure in the corner where a leg is uneven. Keeping pressure in that corner, tighten all bolts. If balanced, apply downward pressure evenly in the center and tighten all bolts. Do not over-tighten beyond hole depth.

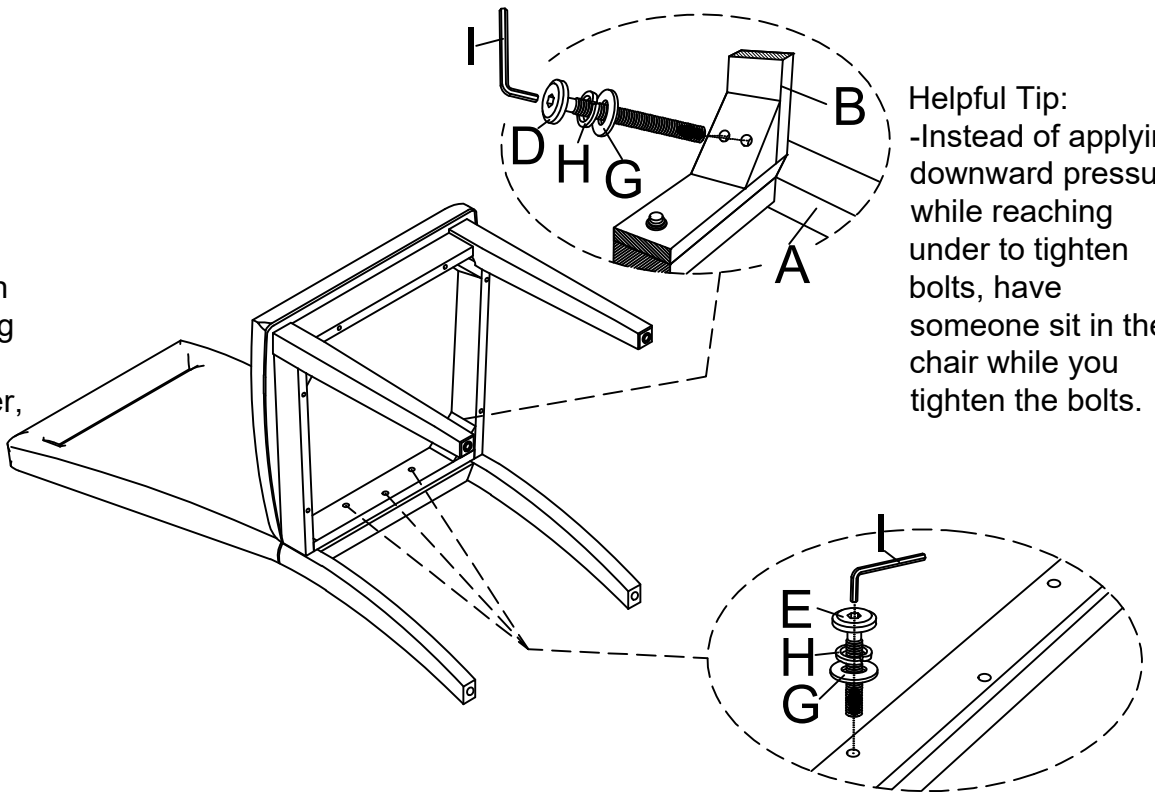

**Helpful Tip:**  
 -Instead of applying downward pressure while reaching under to tighten bolts, have someone sit in the chair while you tighten the bolts.

### Cleaning & Care

Treat surface with care. Surface is resistant to scratches but is not scratch resistant. Clean surface with a dry or damp soft cloth. Do not use abrasive cleaners. Hardware may loosen over time. Periodically check that all connections are tight.