

# F24950

# MCKINLEY

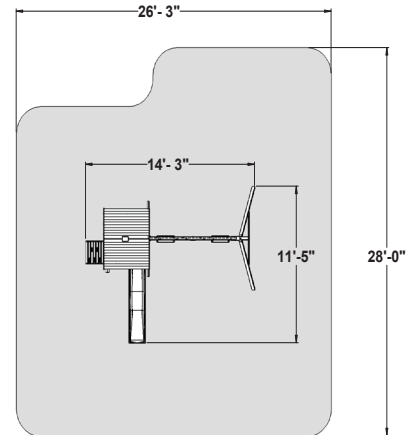


**OBSTACLE FREE SAFETY ZONE** - 26'-3" x 28' area requires Protective Surfacing. See page 4.

**MAXIMUM VERTICAL FALL HEIGHT** - 6'9".

**CAPACITY** -9 Users Maximum, Ages 3 to 10; Weight Limit 110 lbs. (50 kg) per child.

**RESIDENTIAL HOME USE ONLY.** Not intended for public areas such as multi-unit residences, schools, churches, nurseries, day cares or parks.



## INSTALLATION AND OPERATING INSTRUCTIONS

### FOR 24/7 ONLINE PARTS REPLACEMENT

[parts.kidkraft.com](http://parts.kidkraft.com)

KidKraft, Inc.  
4630 Olin Road  
Dallas, Texas 75244  
USA

[customerservice@kidkraft.com](mailto:customerservice@kidkraft.com)

1.800.933.0771  
972.385.0100

[parts.kidkraft.eu](http://parts.kidkraft.eu)

KidKraft Netherlands BV  
Olympisch Stadion 8  
1076 DE Amsterdam  
The Netherlands

[europcustomerservice@kidkraft.com](mailto:europcustomerservice@kidkraft.com)

+31 20 305 8620  
M-F from 09:00 to 17:30 (GMT+1)

9404950

Rev 04/15/2022



### ⚠️ WARNING

To reduce the risk of serious injury or death, please read and follow these instructions. Keep and refer to instructions as needed and pass along to any future owners of this item.

## **Congratulations on purchasing a KidKraft product!**

**Our items are made of high-quality,  
durable Cunninghamia Lanceolata wood  
from the cypress family.**

**Lumber from these trees are known for  
their light weight and excellent strength.  
The porosity of this wood allows the  
moisture to absorb and evaporate in the  
fibers, resisting rot and bugs.**

**Engineered for great play, our products  
also go through extensive testing for safety.**

**Plus, our team has developed a series of  
proprietary methods for a simpler, more  
organized assembly. Less build time and  
more play time is our motto!**

**However, during assembly if you have any  
questions or concerns, please reach out.  
Our Customer Service can help with missing  
parts, instructions or maintenance.**



## Warnings and Safe Play Instructions



**CONTINUOUS ADULT SUPERVISION REQUIRED.** Most serious injuries and deaths on playground equipment have occurred while children were unsupervised! Our products are designed to meet mandatory and voluntary safety standards. Complying with all warnings and recommendations in these instructions will reduce the risk of serious or fatal injury to children using this play system. Go over the warnings and safe play instructions regularly with your children and make certain that they understand and follow them. Remember on-site adult supervision is required for children of all ages.



### WARNING

#### SERIOUS HEAD INJURY HAZARD

Installation over concrete, asphalt, dirt, grass, carpet and other hard surface creates a risk of serious injury or death from falls to the ground. Install and maintain shock absorbing material under and around play-set as recommended on page 3 of these instructions.

#### COLLISION HAZARD

Place play-set on level ground at least 2m from any obstruction such as a garage or house, fences, poles, trees, sidewalks, walls, landscape timbers, rocks, pavement, planters, garden borders, overhanging branches, laundry lines, and electrical wires. (See OBSTACLE FREE SAFETY ZONE on cover)

#### CHOKING HAZARD/SHARP EDGES & POINTS

Adult assembly required. This product contains small parts and parts with sharp edges and points. Keep parts away from children until fully assembled.

#### WARNING LABEL

Owners shall be responsible for maintaining the legibility of the warning labels.

#### STRANGULATION HAZARD

- NEVER allow children to play with ropes, clotheslines, pet leashes, cables, chains or cord-like items when using this play-set or to attach these items to play-set.
- NEVER allow children to wear loose fitting clothing, ponchos, hoods, scarves, capes, necklaces, items with draw-strings, cords or ties when using this play-set.
- NEVER allow children to wear bike or sport helmets when using this play-set.

Failure to prohibit these items, even helmets with chin straps, increases the risk of serious injury and death to children from entanglement and strangulation.

#### TIP OVER HAZARD

Choose a level location for the equipment. This can reduce the likelihood of the play set tipping over and loose-fill surfacing materials washing away during heavy rains.

DO NOT allow children to play on the play-set until the assembly is complete and the unit is properly anchored.

Never add extra length to chain or rope. The chains or ropes provided are the maximum length designed for the swinging element(s).



## WARNING – Safe Play Instructions

- ✓ Observe capacity limitations of your play-set. See front cover.
- ✓ Dress children with well fitting and full foot enclosing footwear.
- ✓ Teach children to sit with their full weight in the center of the swing seat to prevent erratic swing motion or falling off.
- ✓ Check for splintered, broken or cracked wood; missing, loose, or sharp edged hardware. Replace, tighten and or sand smooth as required prior to playing.
- ✓ Verify that suspended climbing ropes, rope ladders, chain or cable are secured at both ends and cannot be looped back on itself as to create an entanglement hazard.
- ✓ On sunny and or hot days, check the slide and other plastic rides to assure that they are not very hot as to cause burns. Cool hot slide and rides with water and wipe dry prior to using.
- ✓ Orientate slide such that it gets the least amount of exposure to the sun.
- ✗ Do not allow children to wear open toe or heel footwear like sandals, flip-flops or clogs.
- ✗ Do not allow children to walk, in front, between, behind or close to moving rides.
- ✗ Do not let children twist swing chains or ropes or loop them over the top support bar. This may reduce the strength of the chain or rope and cause premature failure.
- ✗ Do not let children get off rides while they are in motion.
- ✗ Do not permit climbing on equipment when it is wet.
- ✗ Do not permit rough play or use of equipment in a manner for which it was not intended. Standing on or jumping from the roof, elevated platforms, swings, climbers, ladders or slide can be dangerous.
- ✗ Do not allow children to swing empty rides or seats.
- ✗ Do not allow children to go down slide head first or run up slide.

# ⚠️ Protective Surfacing - Reducing Risk of Serious Head Injury From Falls

One of the most important things you can do to reduce the likelihood of serious head injuries is to install shock-absorbing protective surfacing under and around your play equipment. The protective surfacing should be applied to a depth that is suitable for the equipment height in accordance with ASTM F1292. There are different types of surfacing to choose from; whichever product you select, follow these guidelines:

## Loose-Fill Materials

- Maintain a minimum depth of 9 inches (23 cm) of loose-fill materials such as wood mulch/chips, engineered wood fiber (EWF), or shredded/recycled rubber mulch for equipment up to 8 feet (2.45 m) high; and 9 inches (23 cm) of sand or pea gravel for equipment up to 5 feet (1.5 m) high. NOTE: An initial fill level of 12 inches (31 cm) will compress to about a 9-inch (23 cm) depth of surfacing over time. The surfacing will also compact, displace, and settle, and should be periodically raked and refilled to maintain at least a 9-inch (23 cm) depth.
- Use a minimum of 6 inches (16 cm) of protective surfacing for play equipment less than 4 feet (1.22 m) in height. If maintained properly, this should be adequate. (At depths less than 6 inches (16 cm), the protective material is too easily displaced or compacted.)

NOTE: Do not install home playground equipment over concrete, asphalt, or any other hard surface. A fall onto a hard surface can result in serious injury to the equipment user. Grass and dirt are not considered protective surfacing because wear and environmental factors can reduce their shock absorbing effectiveness. Carpeting and thin mats are not adequate protective surfacing. Ground level equipment -- such as a sandbox, activity wall, playhouse or other equipment that has no elevated play surface -- does not need any protective surfacing.

- Use containment, such as digging out around the perimeter and/or lining the perimeter with landscape edging. Don't forget to account for water drainage.
- Periodically rake, check and maintain the depth of the loose-fill surfacing material. Marking the correct depth on the play equipment support posts will help you to see when the material has settled and needs to be raked and or replenished. Be sure to rake and evenly redistribute the surfacing in heavily used areas.
- Do not install loose fill surfacing over hard surfaces such as concrete or asphalt.

## Poured-In-Place Surfaces or Pre-Manufactured Rubber Tiles

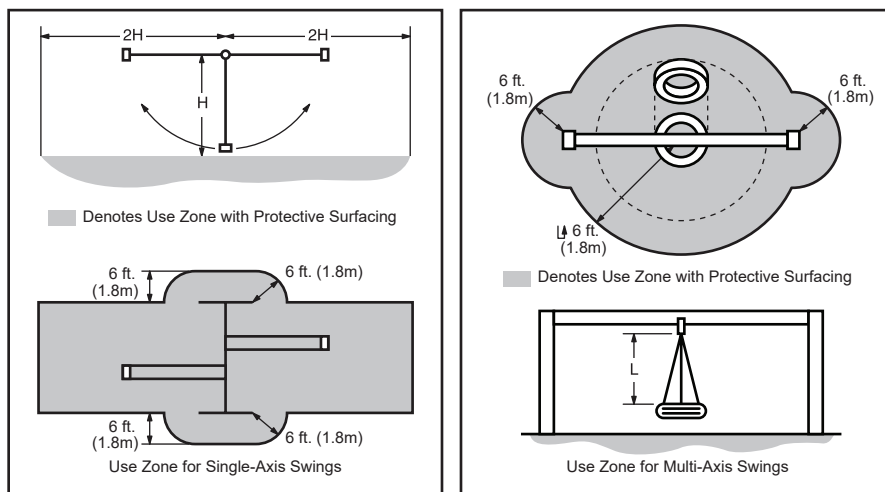
You may be interested in using surfacing other than loose-fill materials - like rubber tiles or poured-in-place surfaces.

- Installations of these surfaces generally require a professional and are not "do-it yourself" projects.
- Review surface specifications before purchasing this type of surfacing. Ask the installer/manufacturer for a report showing that the product has been tested to the following safety standard: ASTM F1292 *Standard Specification for Impact Attenuation of Surfacing Materials within the Use Zone of Playground Equipment*. This report should show the specific height for which the surface is intended to protect against serious head injury. This height should be equal to or greater than the fall height - vertical distance between a designated play surface (*elevated surface for standing, sitting, or climbing*) and the protective surfacing below - of your play equipment.
- Check the protective surfacing frequently for wear.

## Placement

Proper placement and maintenance of protective surfacing is essential. Refer to diagram on front cover. Be sure to;

- Extend surfacing at least 6 feet (1.8 m) from the equipment in all directions.
- For to-fro swings, extend protective surfacing in front of and behind the swing to a distance equal to twice the height of the top bar from which the swing is suspended.
- For tire swings, extend surfacing in a circle whose radius is equal to the height of the suspending chain or rope, plus 6 feet (1.8 m) in all directions.



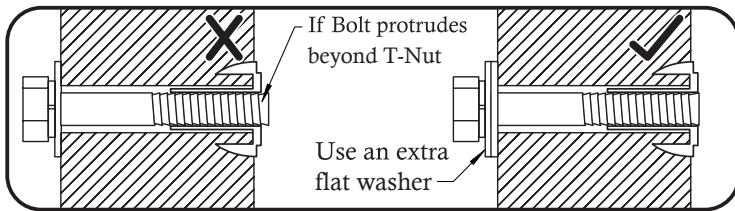
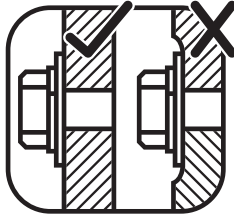
# Instructions for Proper Maintenance

Your KidKraft Play System is designed and constructed of quality materials with your child's safety in mind. As with all outdoor products used by children, it will weather and wear. To maximize the enjoyment, safety and life of your Play Set, it is important that you, the owner, properly maintain it.

## Check the following at the beginning of the play season:

### HARDWARE:

- ✓ Check metal parts for rust. If found, sand and repaint using a non-lead paint complying with 16 CFR 1303.
- ✓ Inspect and tighten all hardware. On wood assemblies **DO NOT OVER-TIGHTEN** as to cause crushing and splintering of wood.
- ✓ Check for sharp edges or protruding screw threads, add washers if required.



### SHOCK ABSORBING SURFACING:

- ✓ Check for foreign objects. Rake and check depth of loose fill protective surfacing materials to prevent compaction and maintain appropriate depth. Replace as necessary. (See Protective Surfacing, page 3)

### GROUND STAKES (ANCHORS):

- ✓ Check for looseness, damage or deterioration. Should firmly anchor unit to ground during use. Re-secure and or replace, if necessary.

### SWING HANGERS:

- ✓ Check that bolts are secure and tight. Quick clips should be completely closed and threaded clips screwed tight.

- ✓ If squeaking occurs lubricate bushings with oil or WD-40®.

### SWINGS, ROPES AND RIDES:

- ✓ Reinstall if removed during cold season. Check all moving parts including swing seats, ropes, chains and attachments for wear, rust and other deterioration. Replace as needed.
- ✓ Check that ropes are tight, secure at both ends and cannot loop back as to create an entrapment.

### WOOD PARTS:

- ✓ Check all wood members for deterioration, structural damage and splintering. Sand down splinters and replace deteriorated wood members. As with all wood, some checking and small cracks in grain is normal.
- ✓ Applying a water repellent or stain (water-based) on a yearly basis is important maintenance to maintain maximum life and performance of the product.

## Check twice a month during play season:

### HARDWARE:

- ✓ Inspect for tightness. Must be firmly against, but not crushing the wood. **DO NOT OVER-TIGHTEN.** This will cause splintering of wood.
- ✓ Check for sharp edges or protruding screw threads. Add washers if required.

### SHOCK ABSORBING SURFACING:

- ✓ Rake and check depth of loose fill protective surfacing materials to prevent compaction and maintain appropriate depth. Replace as necessary. (See Protective Surfacing, page 3)

## Check once a month during play season:

### SWING HANGERS:

- ✓ Check that they are secure and orientated correctly. Hook should rotate freely and perpendicular to support beam.
- ✓ If squeaking occurs lubricate bushings with oil or WD-40®.

### SWINGS AND RIDES:

- ✓ Check swing seats, all ropes, chains and attachments for fraying, wear, excessive corrosion or damage. Replace if structurally damaged or deteriorated.

## Check at the end of the play season:

### SWINGS AND RIDES:

- ✓ To prolong their life, remove swings and store inside when outside temperature is below 32°F/0°C. Below freezing, plastic parts may become more brittle.

### SHOCK ABSORBING SURFACING:

- ✓ Rake and check depth of loose fill protective surfacing materials to prevent compaction and maintain appropriate depth. Replace as necessary. (See Protective Surfacing, page 3)

**If you dispose of your play set:** Please disassemble and dispose of your unit so that it does not create any unreasonable hazards at the time it is discarded. Be sure to follow your local waste ordinances.

## About Our Wood

KidKraft Premium Play Systems uses only premium playset lumber, ensuring the safest product for your children's use. Although we take great care in selecting the best quality lumber available, wood is still a product of nature and susceptible to weathering which can change the appearance of your set.

### **What causes weathering? Does it affect the strength of my Play System?**

One of the main reasons for weathering is the effects of water (moisture); the moisture content of the wood at the surface is different than the interior of the wood. As the climate changes, moisture moves in or out of the wood, causing tension which can result in checking and or warping. You can expect the following due to weathering. These changes will not affect the strength of the product:

1. **Checking** is surface cracks in the wood along the grain. A post 4" x 4" (101mm x 101mm) will experience more checking than a board 1" x 4" (25mm x 101mm) because the surface and interior moisture content will vary more widely than in thinner wood.
2. **Warping** results from any distortion (twisting, cupping) from the original plane of the board and often happens from rapid wetting and drying of the wood.
3. **Fading** happens as a natural change in the wood color as it is exposed to sun-light and will turn a grey over time.

### **How can I reduce the amount of weathering to my Play System?**

At the factory we have coated the wood with a water repellent or stain. This coating decreases the amount of water absorption during rain or snow thus decreasing the tension in the wood. Sunlight will break down the coating, so we recommend applying a water repellent or stain on a yearly basis (see your local stain and paint supplier for a recommended product).

Most weathering is just the normal result of nature and will not affect safe play and enjoyment for your child. However if you are concerned that a part has experienced a severe weathering problem please call our consumer relations department for further assistance.

**Complete and mail registration card to receive important product notifications and assure prompt warranty service.**

# KidKraft Limited Warranty

## MISSING OR DAMAGED PARTS:

KidKraft will replace any parts within 90 days from date of purchase found to be missing from or damaged in the original packaging. See Fig.1

Fig. 1	<u>Product Age (All Parts)</u> 0-90 Days from date of purchase	<u>Consumer Pays</u> \$0 for Part + Free Shipping
--------	---	--

## DEFECTS IN MATERIAL AND WORKMANSHIP:

KidKraft warrants that this product is free from defects in materials and workmanship for a period of one (1) year from the original date of purchase (dated sales receipt and/or product registration is required). This one (1) year warranty covers all parts including wood, hardware, and all accessories (Such as swings, rides, and slides). See Fig. 2

Fig. 2	<u>Product Age (All Parts)</u> 91 Days to 1 Year	<u>Consumer Pays</u> \$0 for Part + Free Shipping
--------	---	--

## WOOD ROT, DECAY, AND INSECT DAMAGE:

All wood carries a five (5) year warranty against rot, decay, and insect damage (dated sales receipt and/or product registration is required). Refer to the schedule below for charges associated with replacement of wood parts under this **Limited Warranty**. See Fig. 3

Fig. 3	<u>Product Age (Wood Parts)</u> 0 Days to 1 Year After 1 Year to 5 Year Over 5 Years	<u>Consumer Pays</u> \$0 for Part + Free Shipping \$0 for Part + Shipping & Handling 100% for Part (if available) + Shipping & Handling
--------	---	--

This warranty applies to the original owner and registrant and is non-transferable. Regular maintenance is required to ensure the integrity of this product. Failure by the owner to maintain the product according to the maintenance requirements may void this warranty.

This Limited Warranty does NOT cover:

- Any inspection cost
- Labor and/or costs for replacement of any defective item(s), including but not limited to, professional installer costs
- Incidental or consequential damages, including but not limited to, as a result of set relocation, move and/or reinstall
- Cosmetic defects which do not affect performance or integrity of a part or the entire product
- Vandalism, improper use or installation, or acts of nature, including but not limited to, high winds, fire, and flood
- Minor twisting, warping, checking, or any natural occurring properties of wood that do not affect performance or integrity.
- Any KidKraft product purchased, including but not limited to, a non-approved retailer, auction houses, second-hand, and as-is clearance items.

KidKraft products have been designed for safety and quality. Modifications made to the original product may damage the structural integrity of the unit leading to failure and possible injury. KidKraft cannot assume any responsibility for the modified products. Furthermore, modifications void all warranties.

This product is warranted for **RESIDENTIAL USE ONLY**. Under no circumstance should a KidKraft product be used in public settings such as schools, churches, playgrounds, parks, home and professional day cares and the like. Such use may lead to product failure and potential injury. Public use will void this warranty. KidKraft disclaims all other representations and warranties of any kind, express or implied.

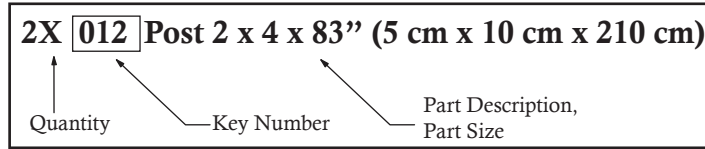
# Keys to Assembly Success

## Tools Required

<ul style="list-style-type: none"> <li>• Tape Measure</li> <li>• Carpenters Level</li> <li>• Carpenters Square</li> <li>• Claw Hammer</li> <li>• Standard or Cordless Drill</li> <li>• Rubber Mallet</li> </ul>	<ul style="list-style-type: none"> <li>• #1 Phillips, #2 Robertson and Screwdriver</li> <li>• Ratchet with extension 1/2" (13mm) &amp; 9/16" (14 mm) sockets</li> </ul>	<ul style="list-style-type: none"> <li>• Open End Wrench 1/2" (13mm) &amp; 9/16" (14 mm)</li> <li>• Adjustable Wrench</li> <li>• 1/8" (3mm) &amp; 3/16" (5mm) Drill Bits</li> </ul>	<ul style="list-style-type: none"> <li>• 3/16" (5mm) Hex Key</li> <li>• 8' (2.4m) Step Ladder</li> <li>• Safety Glasses</li> <li>• Adult Helpers</li> <li>• Pencil</li> </ul>
---	---	---	---

## Part Identification Key

On each page, you will find the parts and quantities required to complete the assembly step illustrated on that page. Here is a sample.



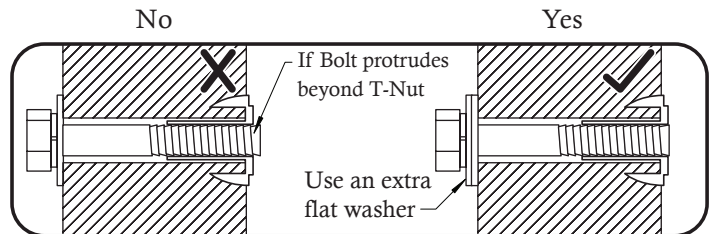
## Symbols

Throughout these instructions symbols are provided as important reminders for proper and safe assembly.

<p>This identifies information that requires special attention. Improper assembly could lead to an unsafe or dangerous condition.</p>	<p>Check that set or assembly is properly level before proceeding.</p> <p>Use Level</p>
<p>Use Help</p> <p>Use Help</p> <p>Where this is shown, 2 or 3 people are required to safely complete the step. To avoid injury or damage to the assembly make sure to get help!</p>	<p>Pre-drill 1/8" (3mm) &amp; 3/16" (5mm) Bit</p> <p>Pre-drill a pilot hole before fastening screw or lag to prevent splitting of wood.</p>
<p>Measure Distance</p> <p>Check that assembly is square before tightening bolts.</p> <p>Square Assembly</p> <p>Use a measuring tape to assure proper location.</p>	<p>Tighten Bolts</p> <p>This indicates time to tighten bolts, but not too tight! Do not crush the wood. This may create splinters and cause structural damage.</p>

## CAUTION – Protrusion Hazard

Once the assembly is tightened, watch for exposed threads. If a thread protrudes from the T-Nut, remove the bolt and add washers to eliminate this condition. Extra washers have been provided for this purpose.

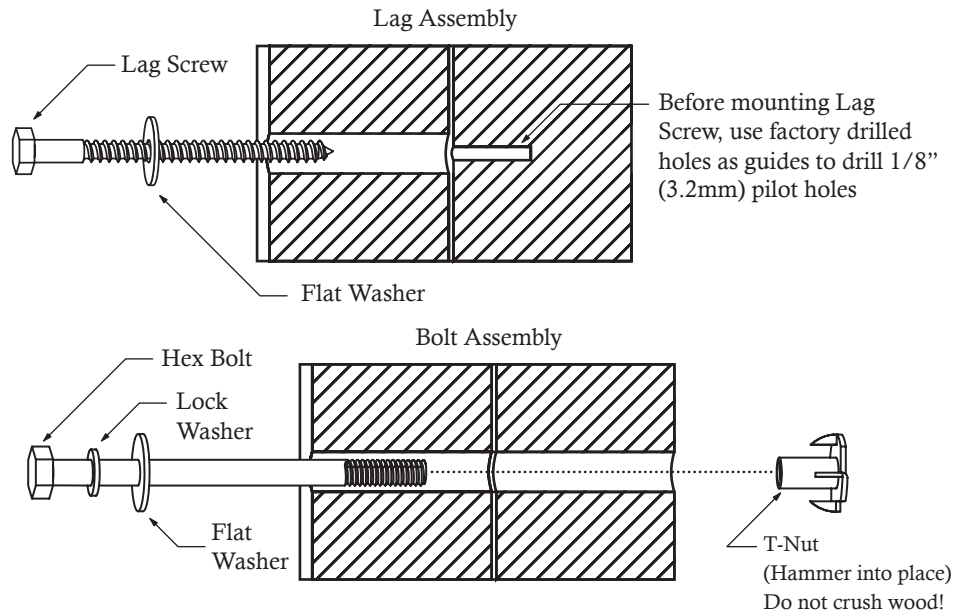


## Proper Hardware Assembly

Lag screws require drilling pilot holes to avoid splitting wood. Only a flat washer is required. For ease of installation liquid soap can be used on all lag-type screws.

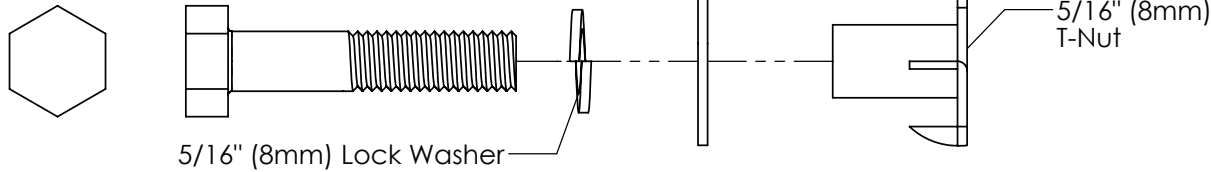
For bolts, tap T-Nut into hole with hammer. Insert the hex bolt through lock washer first then flat washer then hole. Because the assemblies need to be squared do not completely tighten until instructed. Pay close attention to diameter of the bolts. 5/16" (8mm) is slightly larger than 1/4" (6.4mm).

Note: Wafer head bolts with blue lock tight or a bolt with a Ny-Lok nut do NOT require a lock washer.

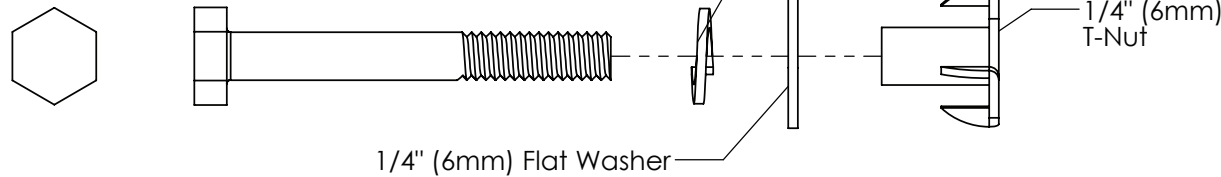


# KIDKRAFT DESIGN HARDWARE

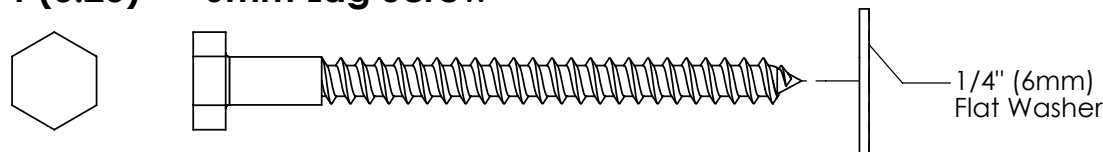
**5/16"(.31) = 8mm Hex Bolt**



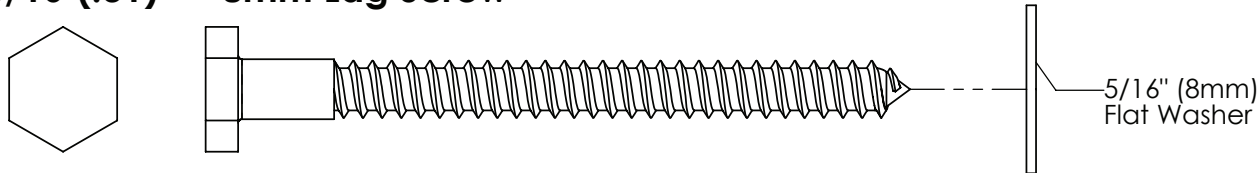
**1/4"(0.25) = 6mm Hex Bolt**



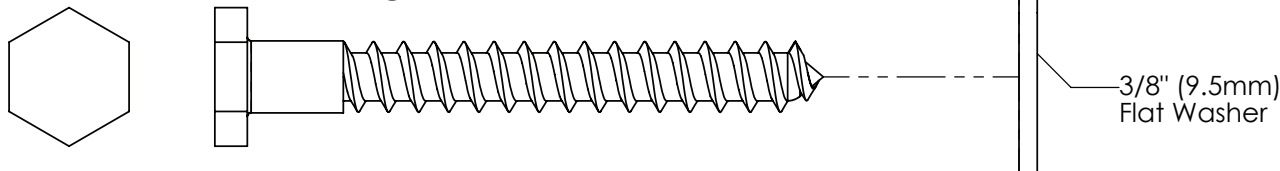
**1/4"(0.25) = 6mm Lag Screw**



**5/16"(.31) = 8mm Lag Screw**



**3/8"(.38) = 9.5mm Lag Screw**



HARDWARE LENGTH CHART	
inches	vs millimetres
6	152
5½	140
5	127
4½	114
4	102
3½	89
3	76
2½	64
2	51
1½	38
1¼	32
1-1/8	29
1	25.4
7/8	22
3/4	19
1/2	12.7

## DIAMETER CONVERSION

$$1 \text{ inch} = 25.4\text{mm}$$

**For example:**

BOLT DIAMETER 5/16 (0.31) inches

$$0.31 \text{ inches} \times 25.4\text{mm} = 8\text{mm}$$

## LENGTH CONVERSION

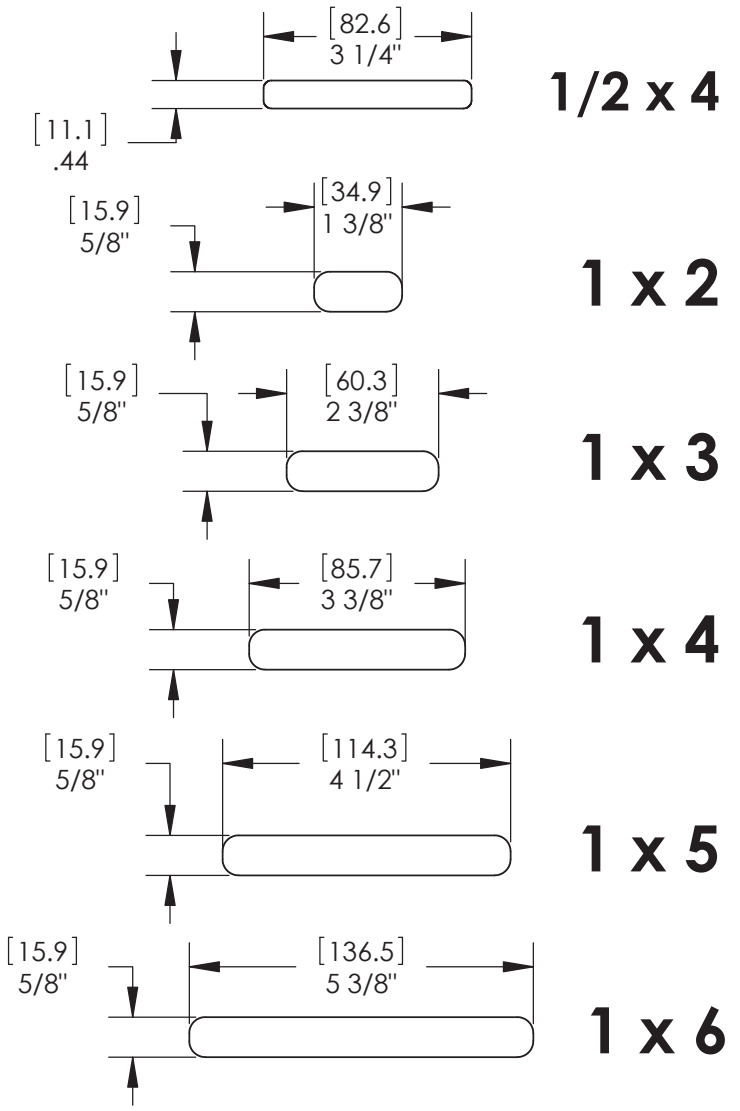
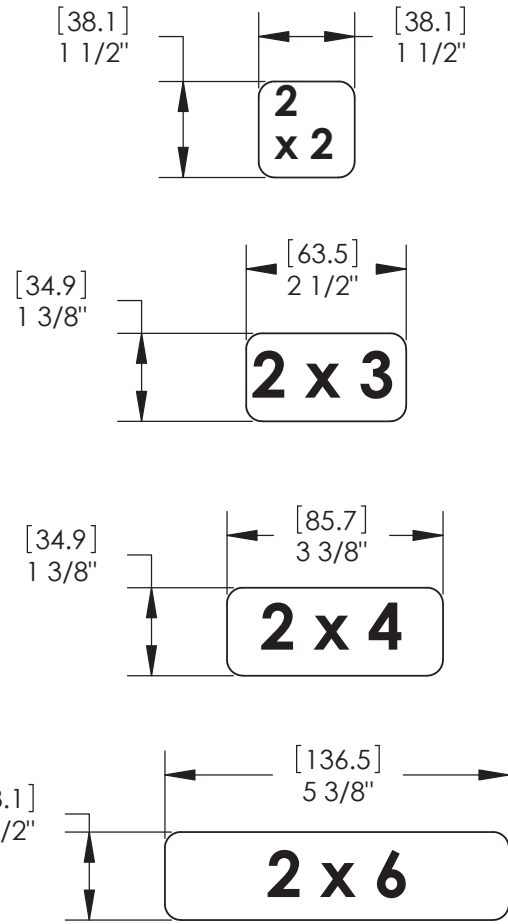
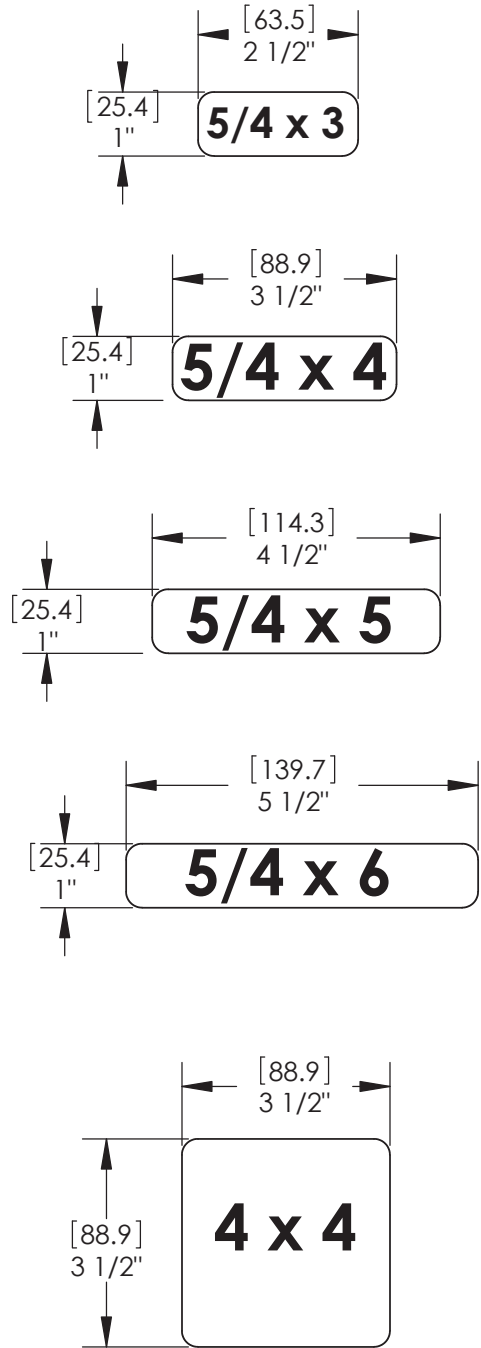
$$1 \text{ inch} = 25.4\text{mm}$$

**For example:**

BOLT LENGTH 4½ (4.5) inches long

$$4.5 \text{ inches} \times 25.4\text{mm} = 114\text{mm long}$$

# KIDKRAFT DESIGN WOOD PROFILES



Dimensions in brackets [mm] represent millimetres.

**LENGTH CONVERSION**

1 inch = 25.4mm


**For example:**  
 BOARD LENGTH 59 1/4 (59.25) inches  
 59.25 inches x 25.4mm = 1505mm


# Part Identification (Reduced Part Size)


Nominal Size	Actual Size
5/4 x 5	15/16 x 4-1/4
5/4 x 6	15/16 x 5-1/4
2 x 2	1-1/2 x 1-1/2
1 x 4	5/8 x 3-3/8
1 x 6	5/8 x 5-3/8
1-1/4 x 2-1/4	1-1/4 x 2-1/4
1-1/4 x 3	1-1/4 x 3
4 x 4	3 x 3
4 x 6	3 x 5-1/4


2pc. - **[2717]** - Clock Block 3/4 x 1-3/4 x 9-3/4"  
 **Box 2 - 3632717**


2pc. - **[5536]** - Counter Side 5/8 x 2 x 6-3/4" - **Box 2 - 38045536**

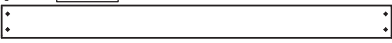
1pc. - **[2686]** - Counter Front 5/8 x 2 3/4 x 40-5/8" - **Box 2 - 3632686**  



2pc. - **[2716]** - Counter Mid Top 1 x 4 x 17-5/8" - **Box 2 - 3632716**  



1pc. - **[2687]** - Counter Back 1 x 4 x 40-5/8" - **Box 2 - 3632687**  



1pc. - **[2685]** - Counter Top 1 x 4 x 40-5/8" - **Box 2 - 3632685**  



8pc. - **[2609]** - 1 x 5 x 40-5/8" - Floor Board - **Box 2 - 3632609**  



1pc. - **[2648]** - 1 x 4 x 40-5/8 - Floor Board - **Box 2 - 3632648**  


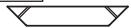
2pc. - **[2605]** - 1 x 6 x 19-3/4" - Access Board - **Box 2 - 3632605**  



2pc. - **[2603]** - 1 x 6 x 19-3/4" - Rock Board A - **Box 2 - 3632603**  


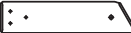
3pc. - **[2604]** - 1 x 6 x 19-3/4" - Rock Board B - **Box 2 - 3632604**  



4pc. - **[5736]** - 1 x 2 x 8-1/4" - Counter Joist - **Box 2 - 38045736**  



1pc. - **[2715]** - 5/4 x 3 x 10" - Door Stop - **Box 2 - 3632715**  



2pc. - **[6136]** - 1 x 2 x 12-9/16" - Counter Brace - **Box 2 - 38046136**  


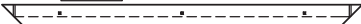
1pc. - **[7567]** - 15/16 x 4-1/4 x 6-1/4" - Chimney Top - **Box 2 - 38047567**  



2pc. - **[2606]** - 5/4 x 4 x 14 1/4" - SW Ground - **Box 2 - 3632606**  



2pc. - **[2610]** - 2 x 2 x 40-1/4" - Side Joist - **Box 2 - 3632610**  


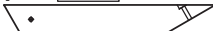
1pc. - **[2616]** - 5/4 x 4 x 46-1/2" - SW Support - **Box 2 - 3632616**  


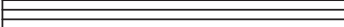
2pc. - **[0349]** - Rock Rail 2 x 3 x 51" - **Box 1 - 3640349**  


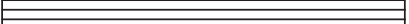
4pc. - **[2617]** - 1-1/4 x 2-1/4 x 37-1/2" - Roof Support - **Box 2 - 3632617**  



2pc. - **[2646]** - 1-1/4 x 3 x 10" - Roof End - **Box 2 - 3632646**  



2pc. - **[2647]** - 1-1/4 x 3 x 10" - Roof End Left - **Box 2 - 3632647**  



2pc. - **[2607]** - 1-1/4 x 3 x 22" - Diagonal - **Box 2 - 3632607**  


1pc. - **[2602]** - Upper Jamb 1 1/4 x 3 x 35-15/16" - **Box 2 - 3632602**  


2pc. - **[2601]** - Lower Jamb 1 1/4 x 3 x 41-15/16" - **Box 2 - 3632601**  


1pc. - **[2608]** - 1-1/4 x 3 x 40-3/4" - Floor Joist - **Box 2 - 3632608**  


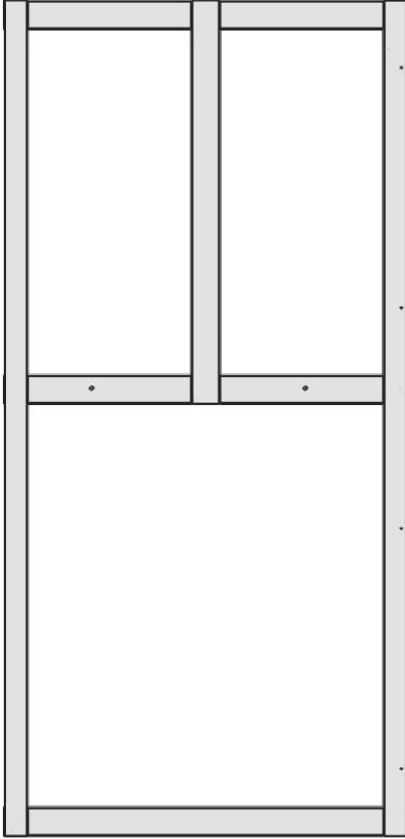
2pc. - **[2613]** - 2 x 3 x 86-11/16" - Heavy SW Post - **Box 1 - 3632613**  


1pc. - **[2615]** - 4 x 4 x 50-15/16" - SW Upright - **Box 1 - 3632615**  


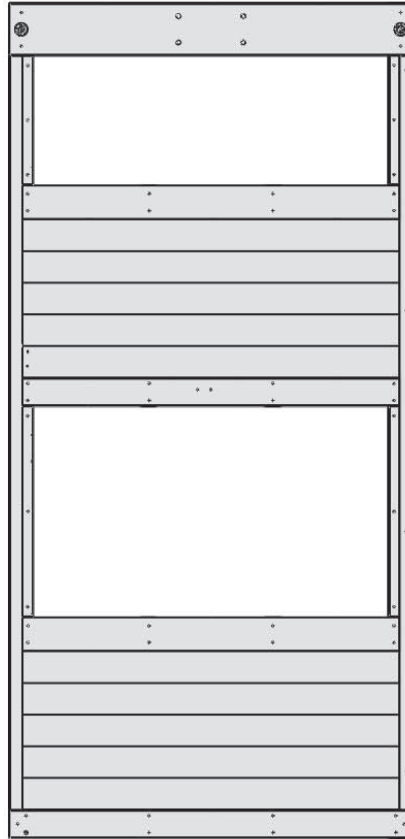
1pc. - **[2614]** - 4 x 6 x 88" - Engineered Beam - **Box 1 - 3632614**  


# Part Identification (Reduced Part Size)

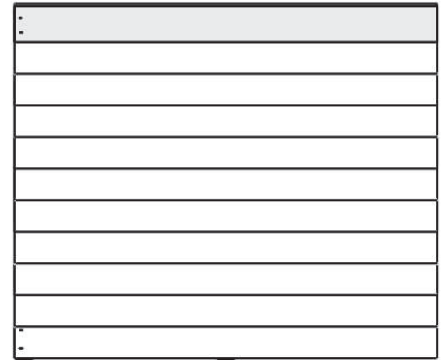
2pc. - **[2618]** Front Back  
 Panel 1¼ x 42 x 87"  
 Box 2 - 37632618



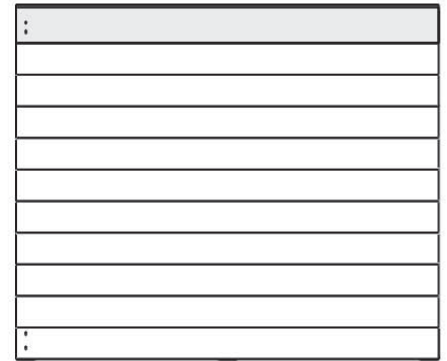
1pc. - **[2627]**  
 SW Wall Panel 1¼ x 42 x 87"  
 Box 2 - 37632627



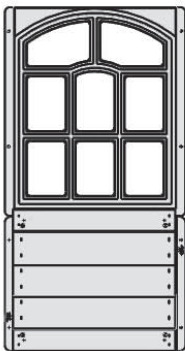
1pc. - **[2639]**  
 Back Roof Panel 1¼ x 36¾ x 44"  
 Box 2 - 37632639



1pc. - **[2644]**  
 Front Roof Panel 1¼ x 37 x 44"  
 Box 2 - 37632644

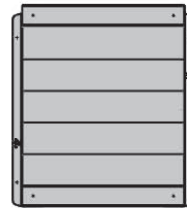
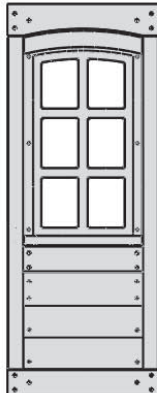


2pc. - **[2719]**  
 Upper Window Insert  
 1.27 x 18.8 x 35.86"  
 Box 2 - 37632719



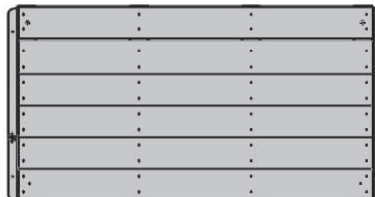
1pc.  
 MOD 3 Pane Transom (2Pk)  
 Box 2 - 3320538

1pc. - **[2718]**  
 Door Window Panel  
 1¼ x 15¾ x 40¾"  
 Box 2 - 37602718B

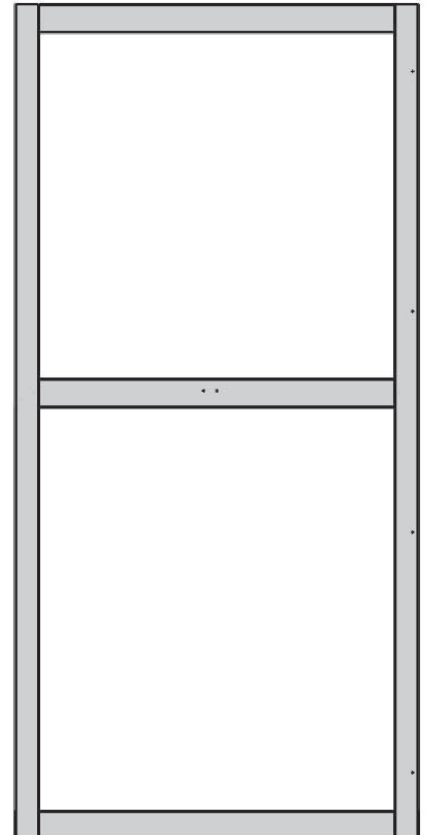


2pc. - **[649A]**  
 Short Half Wall - 1.27 x 18.8 x 20-15/16"  
 Box 2 - 37632649A

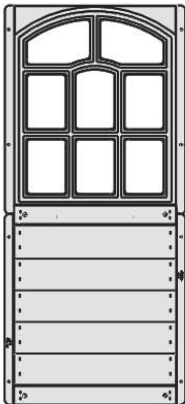
1pc. - **[2665]**  
 Half Wall Insert - 1.4 x 20¼ x 38.8"  
 Box 2 - 37632665



1pc. - **[2622]**  
 End Panel Assembly 1¼ x 42 x 87"  
 Box 2 - 37632622



2pc. - **[2720]**  
 Lower Window Insert  
 1.27 x 18.8 x 41.91"  
 Box 2 - 37632720

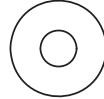


# Hardware Identification (Actual Size)

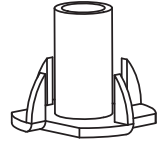
5pc. **LW2** - 5/16" Lock Washer - (51303300)



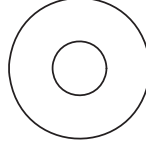
5pc. **FW0** - 3/16" Flat Washer - (51103100)



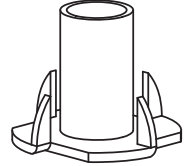
10pc. **TN1** - 1/4" T - Nut  
(54503200)



12pc. **FW1** - 1/4" Flat Washer - (51103200)



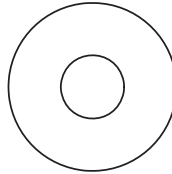
8pc. **TN2** - 5/16" T - Nut - (54503300)



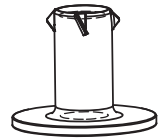
15pc. **LW1** - 1/4" Lock Washer - (51303200)



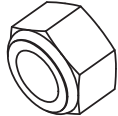
66pc. **FW2** - 5/16" Flat Washer - (51103300)



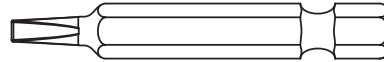
5pc. **BN1** - 1/4" Barrel Nut - (54803200)



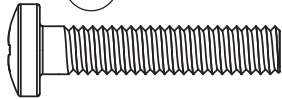
29pc. **LN2** - 5/16" Lock Nut - (54303300)



1pc. **D4** - 2 x 2 Robertson Driver Bit - (9200014)



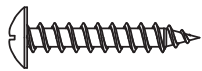
5pc. **PB2** - Pan Bolt 1/4 x 1-1/4"  
- (53433212)



4pc. **S18** - Wood Screw #6 x 1" - (52013910)



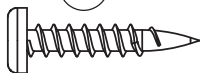
69pc. **S0** - Truss Screw #8 x 7/8" - (52933505)



77pc. **S20** - Wood Screw #8 x 1-3/8" - (52043516)



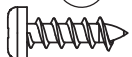
5pc. **S10** - Pan Screw #8 x 1"  
- (52433510)



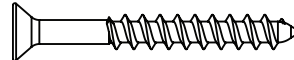
28pc. **S11** - Wood Screw #8 x 2" - (52043520)



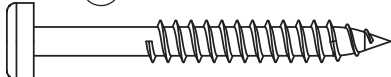
22pc. **S13** - Pan Screw #8 x 5/8" - (52433908)



4 x **S2** - Wood Screw #8 x 1-1/2" - (52043512)  
38.1mm



13pc. **S7** - Pan Screw #12 x 2" - (52433620)



14pc. **S3** - Wood Screw #8 x 2-1/2" - (52043522)

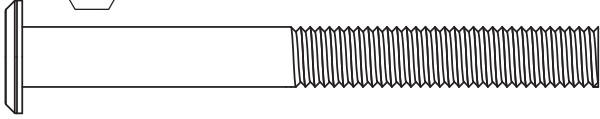


12pc. **S4** - Wood Screw #8 x 3" - (52043530)

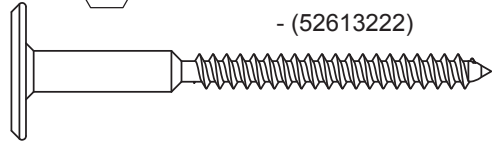


# Hardware Identification (Actual Size)

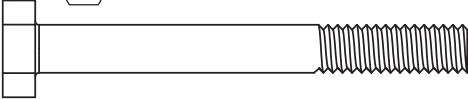
3pc. **WB7** - Wafer Bolt 5/16 x 3" - (53613330)



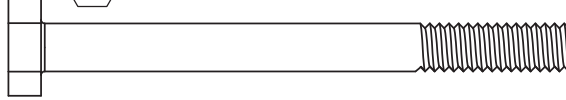
16pc. **WL5** - Wafer Lag 1/4 x 2-1/2" - (52613222)



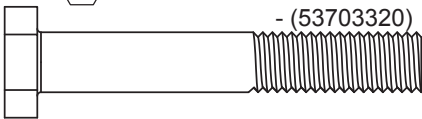
2pc. **H10** - Hex Bolt 1/4 x 2-1/4" - (53703221)



4pc. **H11** - Hex Bolt 1/4 x 2-3/4" - (53703223)

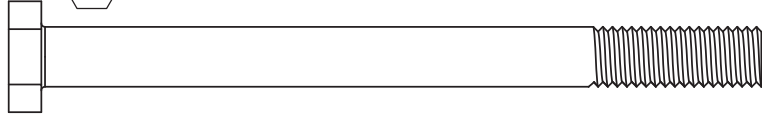


4pc. **G8** - Hex Bolt 5/16 x 2"

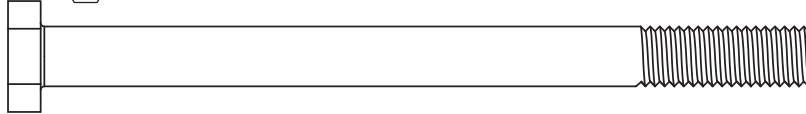


- (53703320)

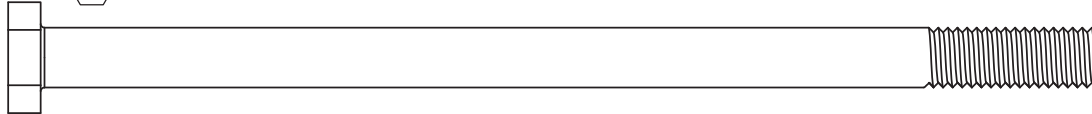
7pc. **G21** - Hex Bolt 5/16 x 3-3/4" - (53703333)



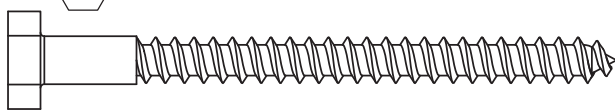
3pc. **G4** - Hex Bolt 5/16 x 4" - (53703340)



14pc. **G7** - Hex Bolt 5/16 x 5-1/2" - (53703352)



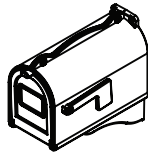
2pc. **LS3** - Lag Screw 1/4 x 3" - (52213230)



# Part Identification (Reduced Part Size)



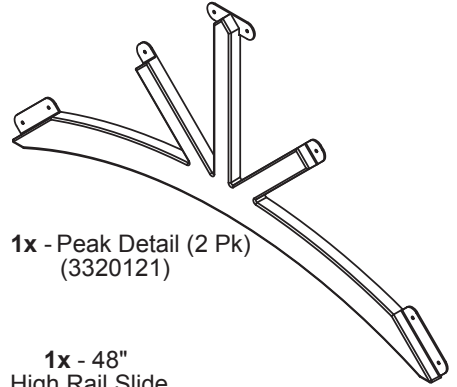
1x - KidKraft ID Plaque (9320374)



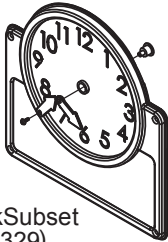
1x - Mailbox (3320107)



1x - Clicker Phone (3320252)

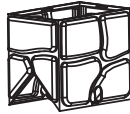


1x - Peak Detail (2 Pk) (3320121)



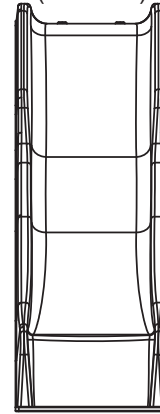
1x - Base Clock (9320124)

1x - ClockSubset (3320329)

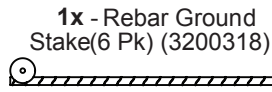


1x - ChimneyWall (9320606)

1x - 48" High Rail Slide (7310248)



1x - Quick Link with Thread (6 Pk) (3206020)



1x - Rebar Ground Stake (6 Pk) (3200318)

1x - Rocks (5pk) (3320386)



1x - Kidkraft Logo Plaque (3320353)



2x - Jamb Mount (9206300)

1x - Welded Chain Bag (3200170) Green



4x 9201254 54" chain - Green



2x 9201225 25" chain - Green

1x - Bracket Set (3206303)



1x - JambMount (4 Pk) (3206302)



1x - Narrow Angle Bracket (3 Pk) (3200640)

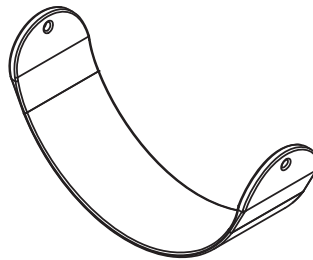
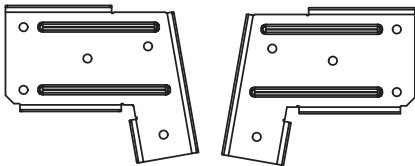


1x - Swing Hanger (6 Pk) (3206106)



2x - Acro Handle (9320131) Green

1x - Beam Brkt. Set (3200143)



2x - Swing Belt Seat (9320130) Green

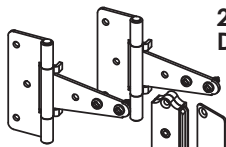


1x - Acro Bar (9200130) Green



1x - Beam L Brkt. (3200145) (2pk)

1x - Door Hardware (3201710)



2x 9201713 Door Hinge

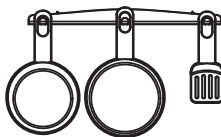
9207713 Door Catch

1x Magnetic Catch  
1x Catch Plate

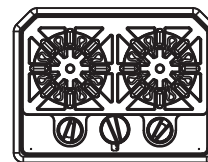


2x 9207711 Door Handle

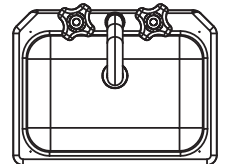
1x - Deluxe Kitchen Set (3320969)



1x - Utensil Shelf

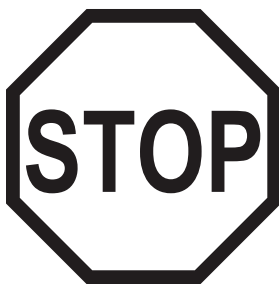
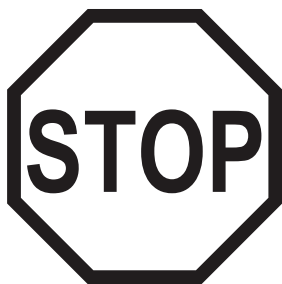


1x - Deluxe Stove Assembly



1x - Deep Sink, Faucet, Knobs

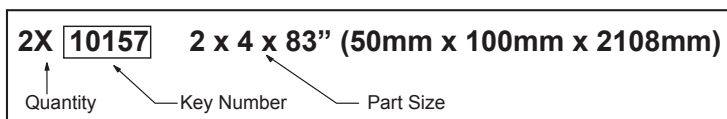
# 1 Inventory Parts - Read This Before Starting Assembly



Inventory should be completed before starting installation. KidKraft will not cover costs of any additional installation trip due to missing or damaged pieces.

A. This is the time for you to inventory all your hardware, wood and accessories, referencing the parts identification sheets. This will assist you with your assembly.

- The wood pieces will have the key number stamped on the ends of the boards. Organize the wood pieces by step, as per the key numbering system below.



B. Read the assembly manual completely, paying special attention to ANSI warnings; notes; and safety/maintenance information on pages 1 - 8.

**If there are missing or damaged pieces,  
please contact the KidKraft Consumer Engagement team  
before going back to the retailer.**

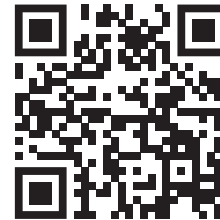
## Order Replacement Parts 24/7

You can order replacement parts for this product 24 hours a day / 7 days a week:

**Outdoor Swingsets and Playhouse Parts Ordering**

**<https://parts.kidkraft.com/partsorderemail>**

If you have assembly or product questions, please refer to the front cover for direct contact information for our Consumer Engagement team OR you can also use this QR code with your smartphone for common questions and contact information.



**KidKraft Help Center** <https://kidkraft.zendesk.com/hc/en-us/>

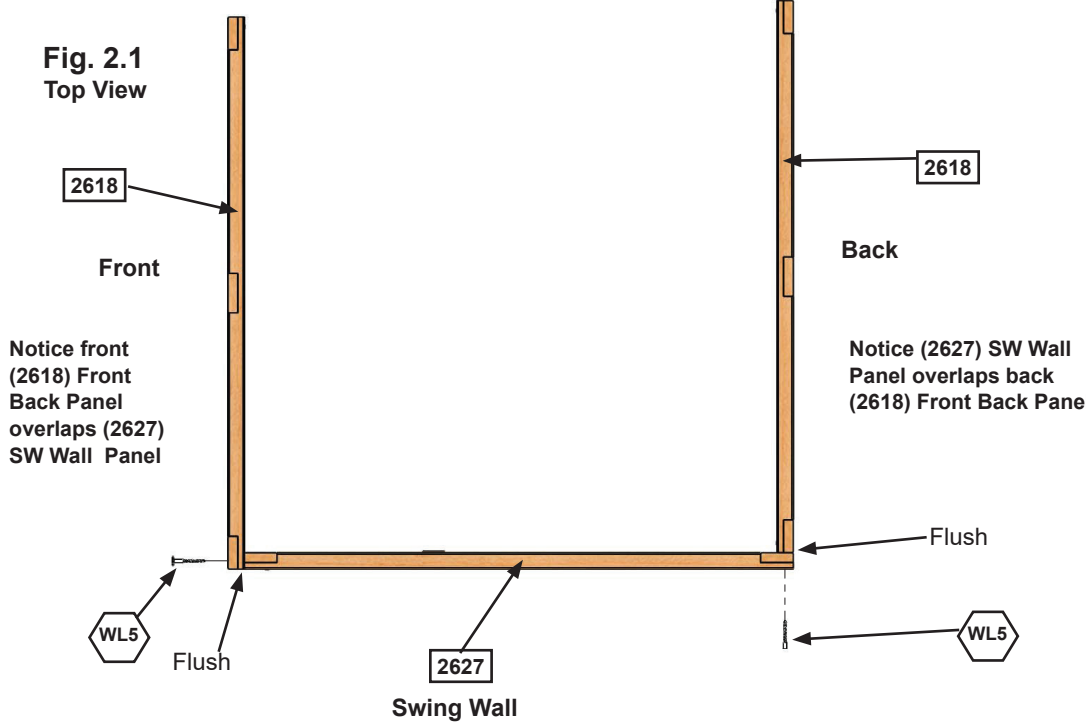
# Step 2: Frame Assembly Part 1



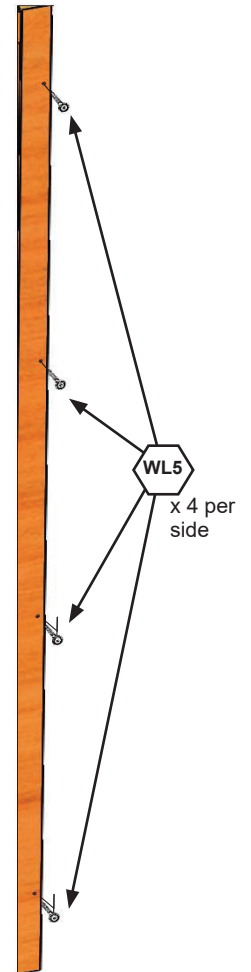
*It is important to assemble the frame on a flat, smooth surface.*

**A:** Place (2627) SW Wall Panel between 2 (2618) Front Back Panels noticing the panel orientations. The tops and bottoms of the panels should be flush. Make sure the panels are square then using the pilot holes as a guide pre-drill with a 3/16" drill bit and fasten the front (2618) Front Back Panel to (2627) SW Wall Panel and (2627) SW Wall Panel to the back (2618) Front Back Panel with 4 (WL5) 1/4 x 2-1/2" Wafer Lags per side. (fig. 2.1, 2.2 and 2.3)

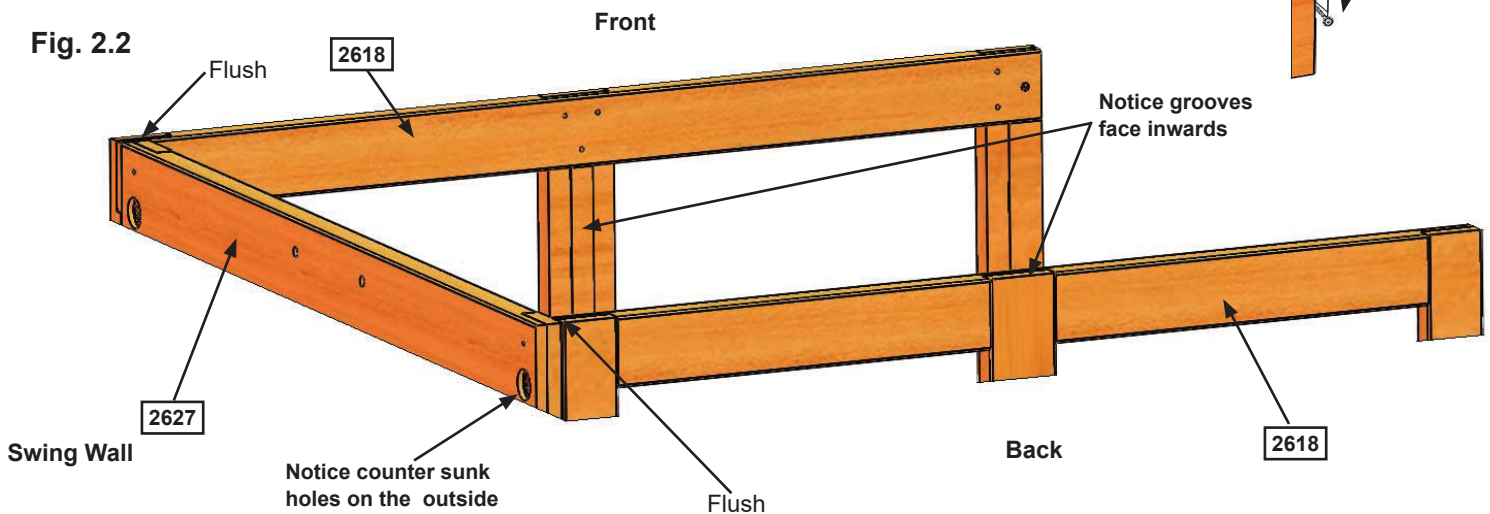
**Fig. 2.1**  
Top View



**Fig. 2.3**



**Fig. 2.2**



**Wood Parts**

- 2 x 2618 Front Back Panel 1-1/4 x 42 x 87"
- 1 x 2627 SW Wall Panel 1-1/4 x 42 x 87"

**Hardware**

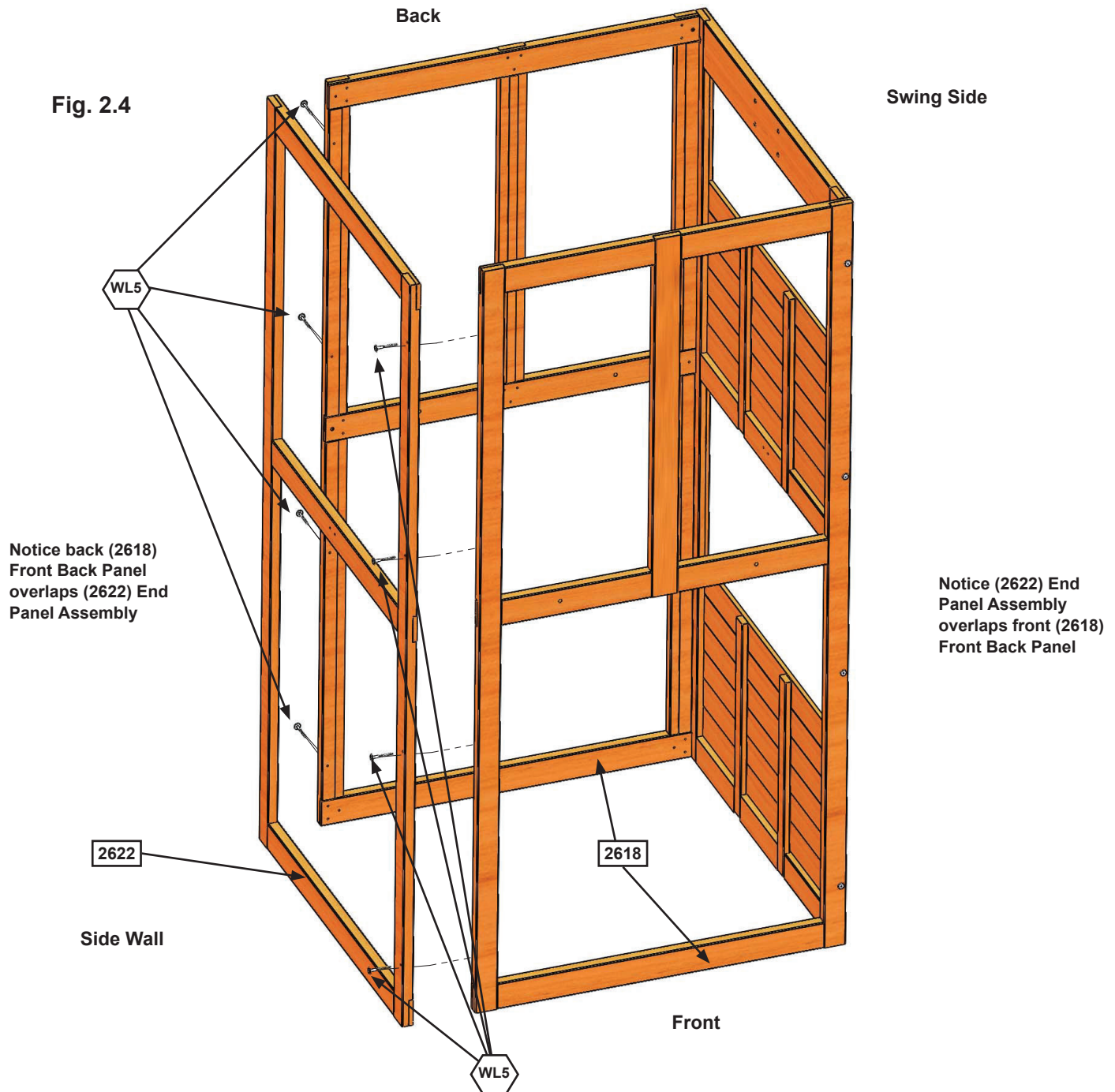
- 8 x WL5 1/4 x 2-1/2" Wafer Lag

# Step 2: Frame Assembly Part 2



**B:** Place (2622) End Panel Assembly between both (2618) Front Back Panels noticing the panel orientations. The tops and bottoms of the panels should be flush. Make sure the panels are square then using the pilot holes as a guide pre-drill with a 3/16" drill bit and fasten the back (2618) Front Back Panel to (2622) End Panel Assembly and (2622) End Panel Assembly to the front (2618) Front Back Panel with 4 (WL5) 1/4 x 2-1/2" Wafer Lags per side. (fig. 2.4)

Fig. 2.4



### Wood Parts

1 x **2622** End Panel Assembly 1-1/4 x 42 x 87"

### Hardware

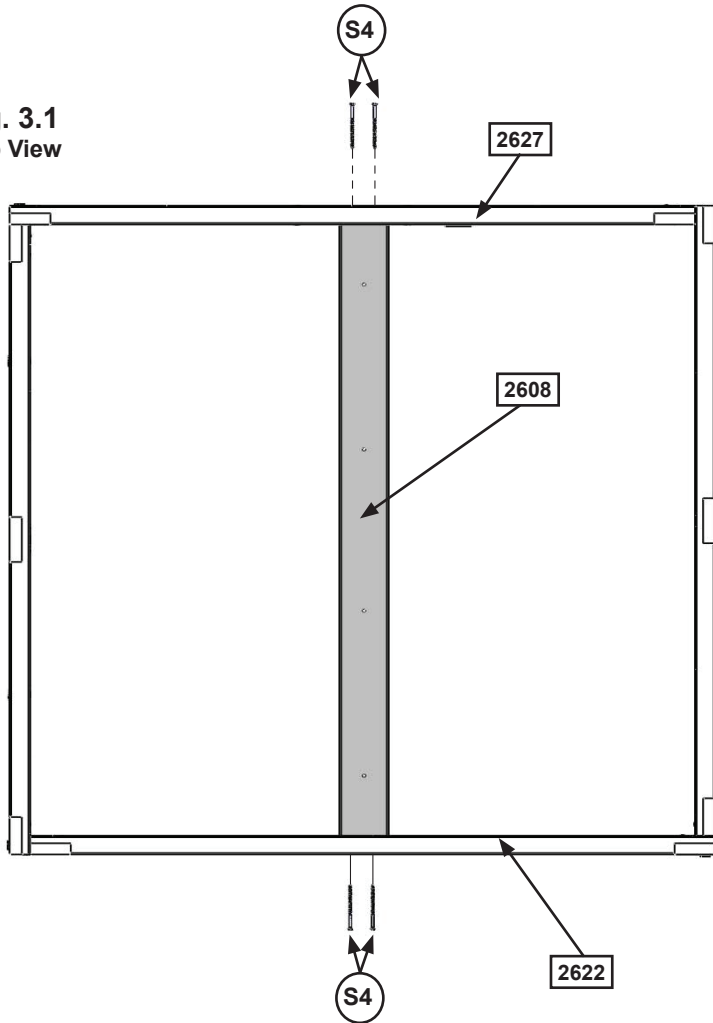
8 x **WL5** 1/4 x 2-1/2" Wafer Lag

# Step 3: Floor Assembly Part 1

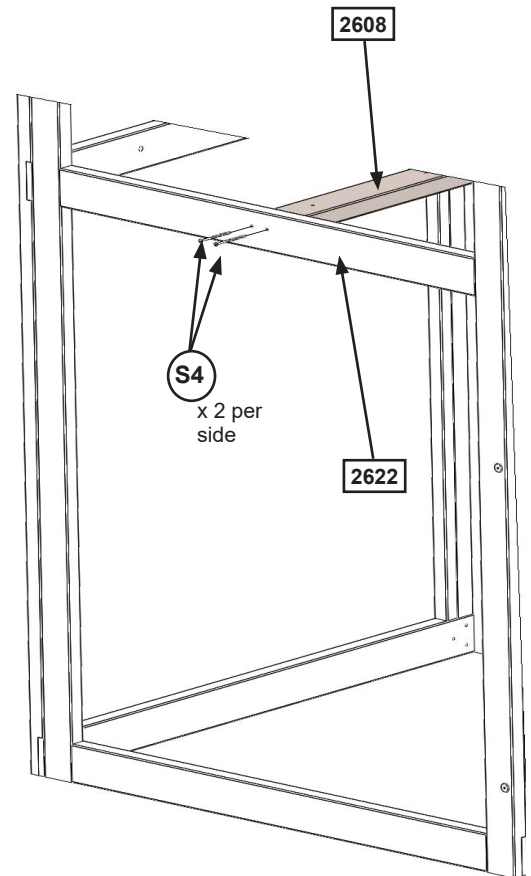


**A:** From inside the assembly centre (2608) Floor Joist over pilot holes in (2622) End Panel Assembly and (2627) SW Wall Panel, 5/8" down from the top of board then attach (2608) Floor Joist to each panel with 2 (S4) #8 x 3" Wood Screws per end. (fig.3.1, 3.2 and 3.3)

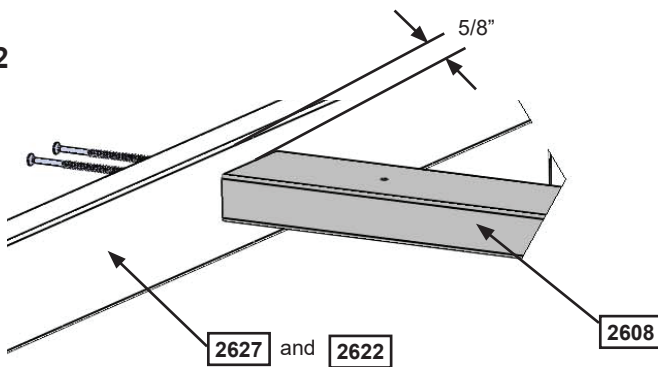
**Fig. 3.1**  
Top View



**Fig. 3.3**



**Fig. 3.2**



**Wood Parts**

1 x **2608** Floor Joist 1-1/4 x 3 x 40-3/4"

**Hardware**

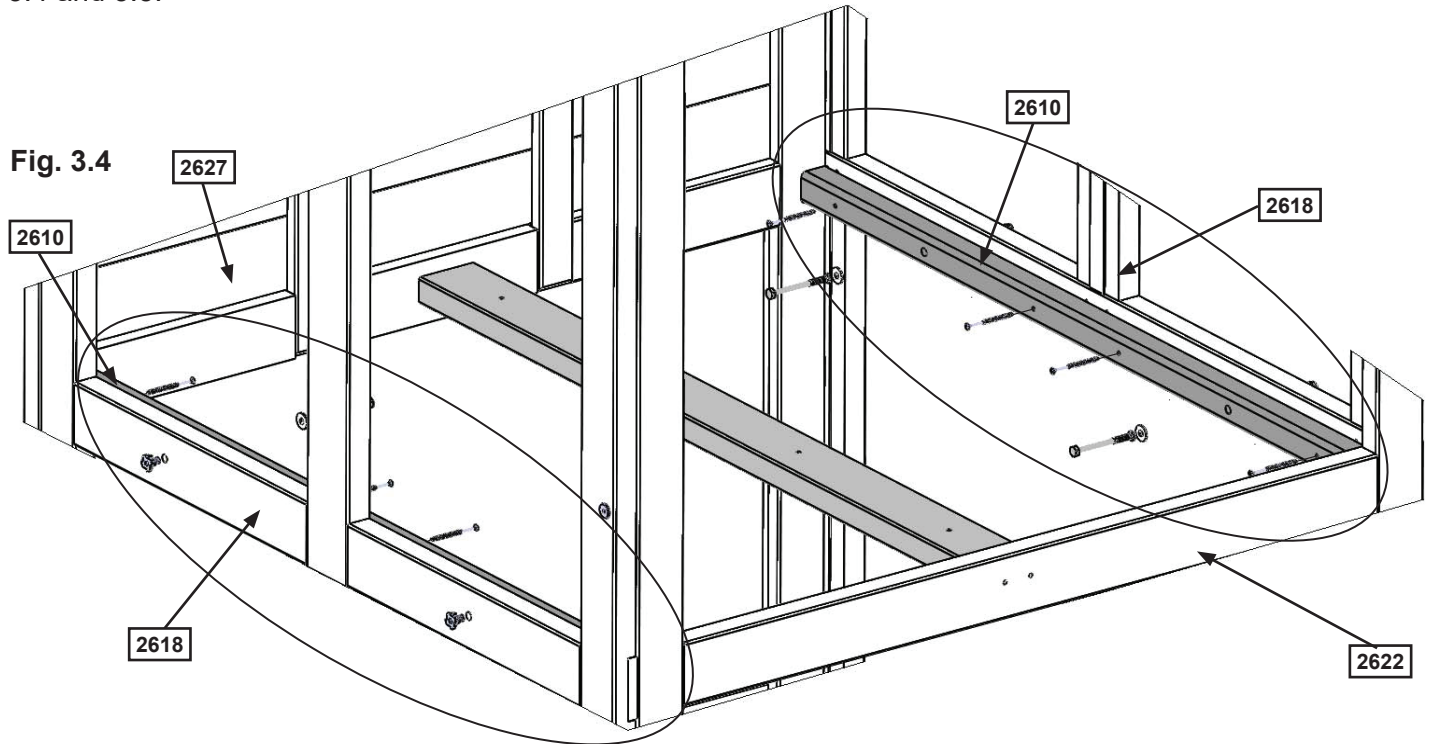
4 x **S4** #8 x 3" Wood Screw

# Step 3: Floor Assembly Part 2

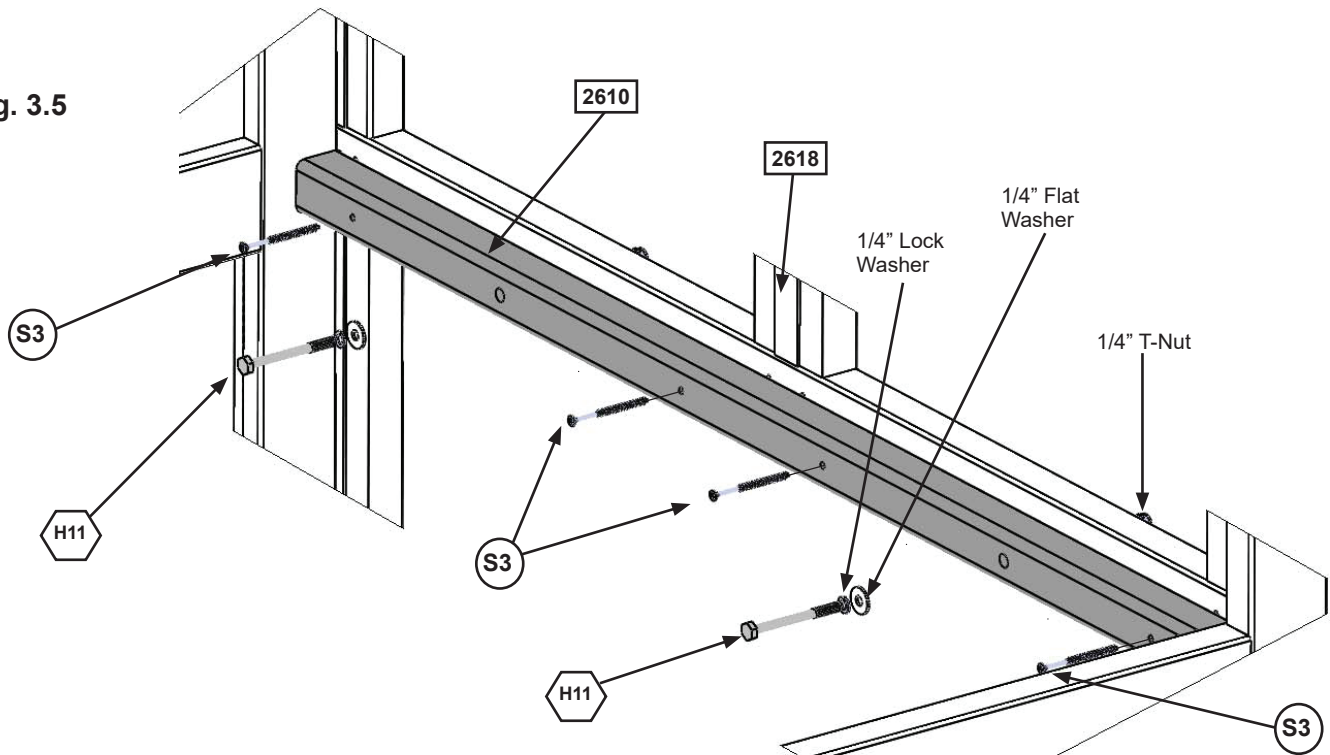


**B:** On both (2618) Front Back Panels attach 1 (2610) Side Joist to the inside of each panel with 2 (H11) 1/4 x 2-3/4" Hex Bolts (with lock washer, flat washer and t-nut) and 4 (S3) #8 x 2-1/2" Wood Screws as shown in fig. 3.4 and 3.5.

**Fig. 3.4**



**Fig. 3.5**



**Wood Parts**

2 x 2610 Side Joist 2 x 2 x 40-1/4"

**Hardware**

8 x S3 #8 x 2-1/2" Wood Screw

4 x H11 1/4 x 2-3/4" Hex Bolt  
(1/4" lock washer, 1/4" flat washer, 1/4" t-nut)

# Step 3: Floor Assembly Part 3

**C:** Starting at (2627) SW Wall Panel place (2648) Floor Board followed by 8 (2609) Floor Boards. Make sure all boards are evenly spaced then attach to (2608) Floor Joist and each (2610) Side Joist with 5 (S20) #8 x 1-3/8" Wood Screws per board. (fig. 3.6 and 3.7)

Fig. 3.6

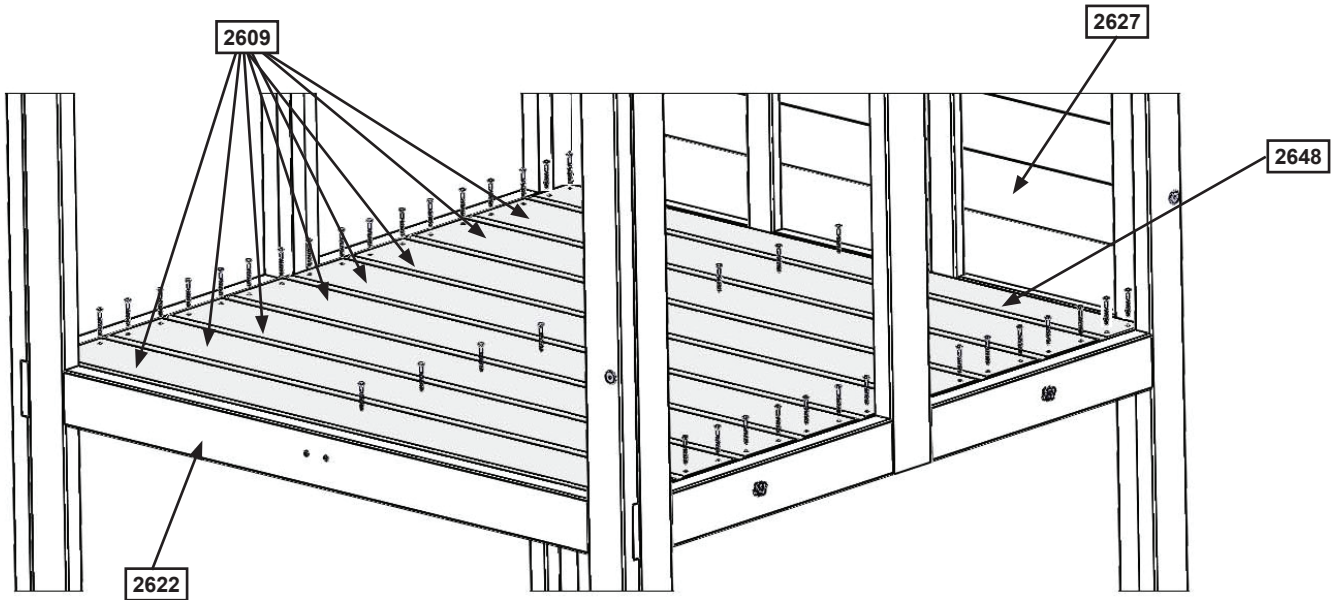
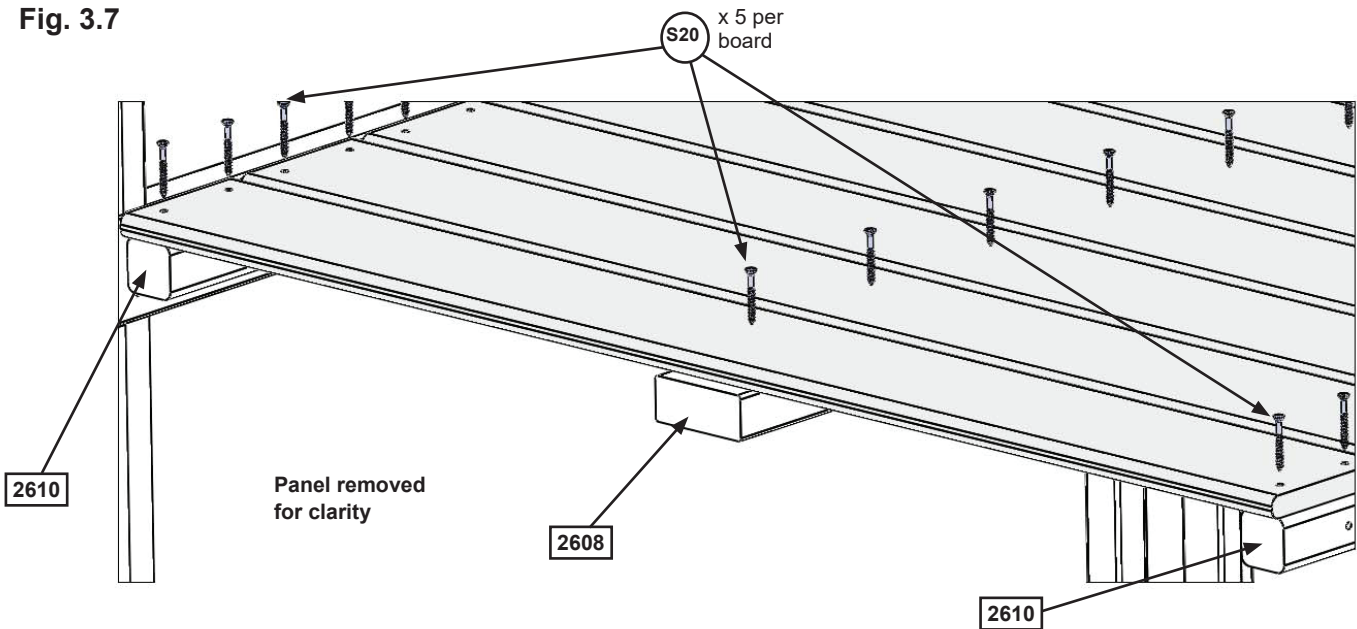


Fig. 3.7



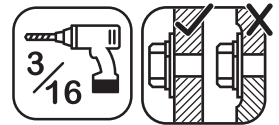
### Wood Parts

- 1 x 2648 Floor Board 1 x 4 x 40-5/8"
- 8 x 2609 Floor Board 1 x 5 x 40-5/8"

### Hardware

- 45 x S20 #8 x 1-3/8" Wood Screw

## Step 4: Attach SW Ground and Diagonal



**A:** Loosely attach 1 (2606) SW Ground to each (2607) Diagonal with 1 (H10) 1/4 x 2-1/4" Hex Bolt (with lock washer, flat washer and t-nut) per board then place each (2607) Diagonal tight and flush to the front of (2627) SW Wall Panel. (2606) SW Grounds to be flush to the bottom of (2627) SW Wall Panel. (fig. 4.1 and 4.2)

**B:** Pre-drill pilot hole with a 3/16" drill bit then attach each (2607) Diagonal to (2627) SW Wall Panel with 1 (LS3) 1/4 x 3" Lag Screw (with flat washer) per board, checking that they remain flush to outside edge. (fig. 4.1 and 4.2)

**C:** Make sure bottom of each (2606) SW Ground is flush to bottom of (2627) SW Wall Panel then attach with 2 (S11) #8 x 2" Wood Screws and 1 (S4) #8 x 3" Wood Screw per board. Tighten all bolts. (fig. 4.1 and 4.2)

Fig. 4.1

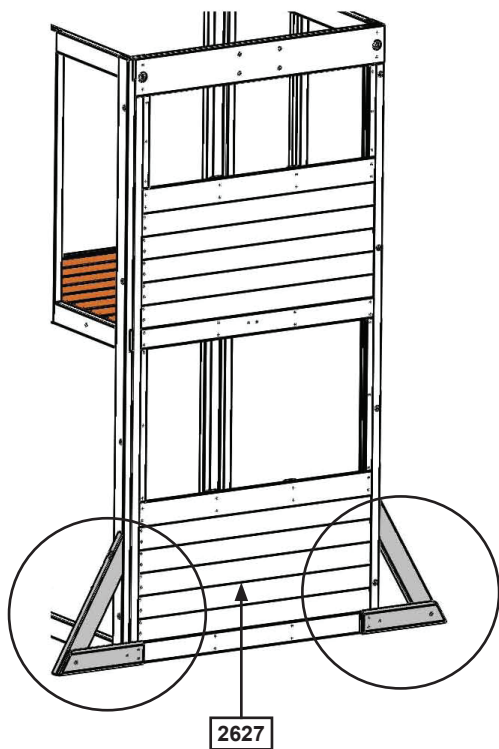
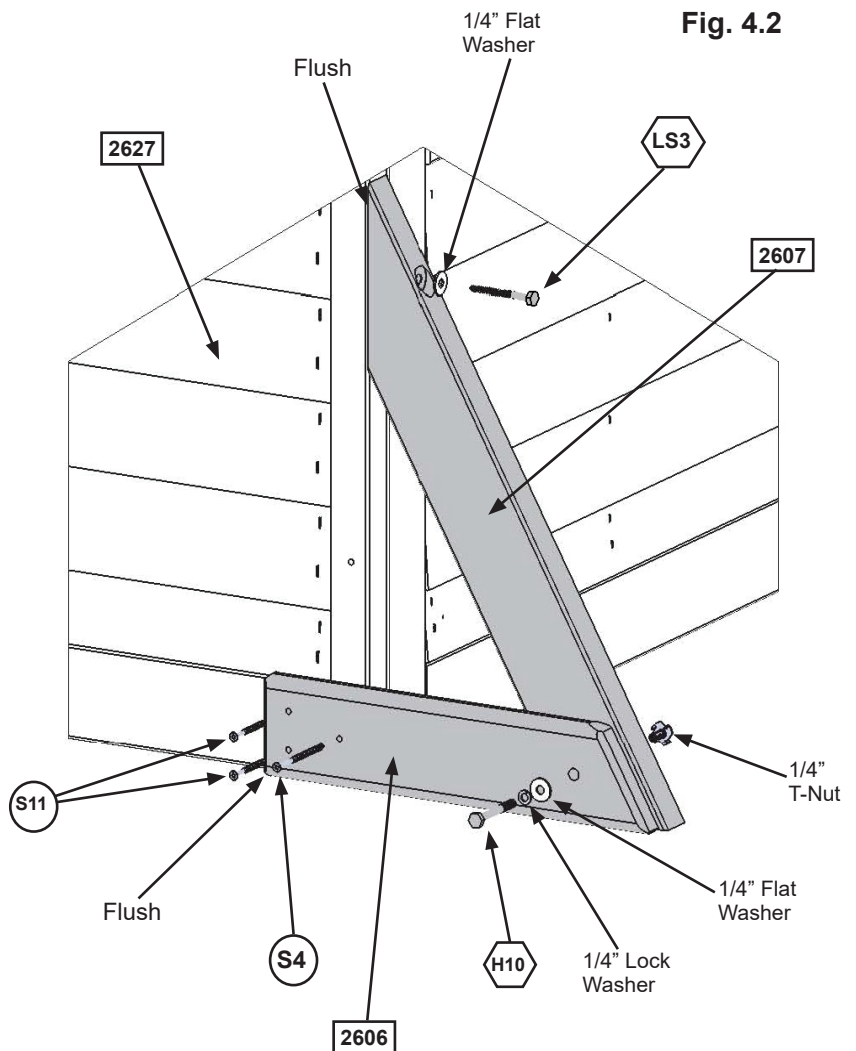


Fig. 4.2

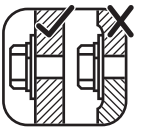


### Wood Parts

- 2 x SW Ground 5/4 x 4 x 14-1/4"
- 2 x Diagonal 1-1/4 x 3 x 22"

### Hardware

- 2 x 1/4 x 2-1/4" Hex Bolt (1/4" lock washer, 1/4" flat washer, 1/4" t-nut)
- 2 x 1/4 x 3" Lag Screw (1/4" flat washer)
- 2 x #8 x 3" Wood Screw
- 4 x #8 x 2" Wood Screw



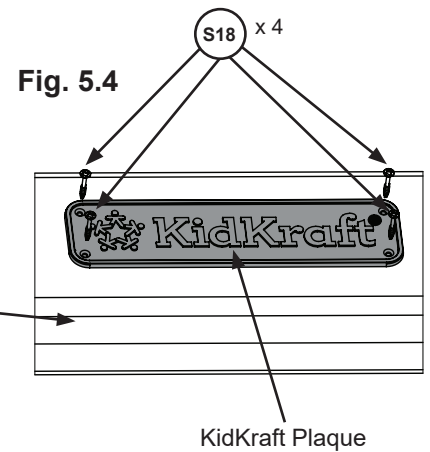
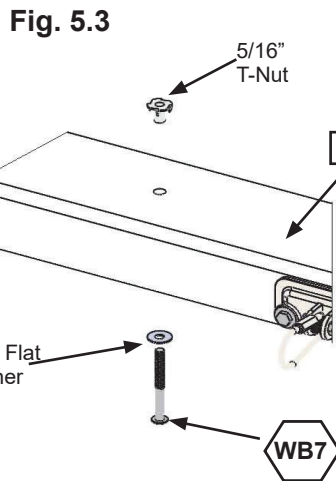
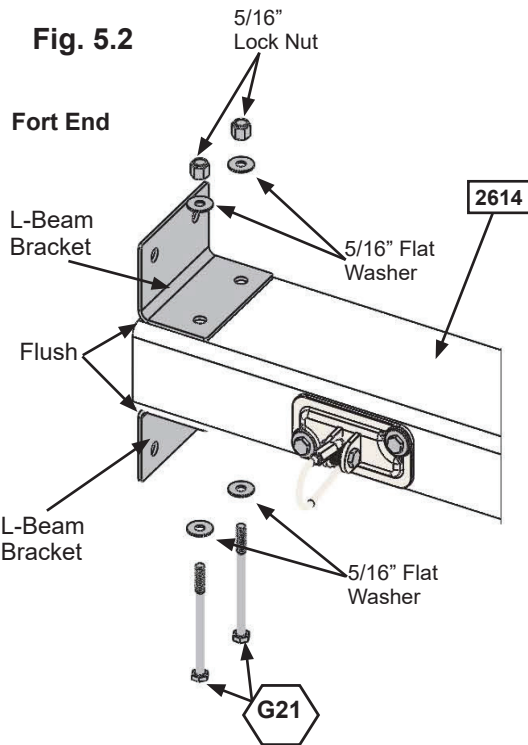
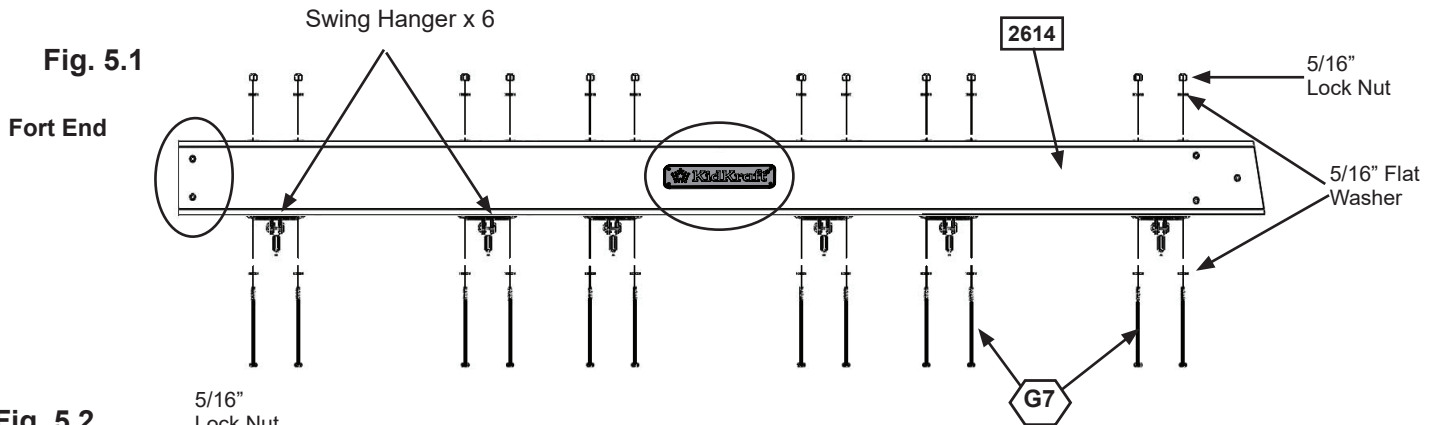
# Step 5: Swing Beam Assembly

**A:** Attach 6 Swing Hangers to (2614) Engineered Beam using 2 (G7) 5/16 x 5-1/2" Hex Bolts (with 2 flat washers and 1 lock nut) per Swing Hanger, as shown in fig. 5.1.

**B:** Flush to the Fort End of (2614) Engineered Beam attach 2 L-Beam Brackets with 2 (G21) 5/16 x 3-3/4" Hex Bolts (with 2 flat washers and 1 lock nut). (fig. 5.2)

**C:** Install 1 (WB7) 5/16 x 3" Wafer Bolt (with flat washer and t-nut) in the middle bolt hole in (2614) Engineered Beam as shown in fig. 5.3. **IT IS IMPORTANT THAT THIS BOLT IS ATTACHED. IT WILL MINIMIZE CHECKING OF WOOD.**

**D:** Attach KidKraft Plaque to centre of (2614) Engineered Beam (over top of t-nut) using 4 (S18) #6 x 1" Wood Screws. (fig. 5.4)



### Wood Parts

1 x 2614 Engineered Beam 4 x 6 x 88"

### Hardware

- 12 x G7 5/16 x 5-1/2" Hex Bolt (5/16" flat washer x 2, 5/16" lock nut)
- 2 x G21 5/16 x 3-3/4" Hex Bolt (5/16" flat washer x 2, 5/16" lock nut)
- 1 x WB7 5/16 x 3" Wafer Bolt (5/16" flat washer & 5/16" t-nut)
- 4 x S18 #6 x 1" Wood Screw

### Other Parts

- 6 x Swing Hangers
- 2 x L-Beam Bracket
- 1 x KidKraft Plaque

## Step 6: Swing End Assembly

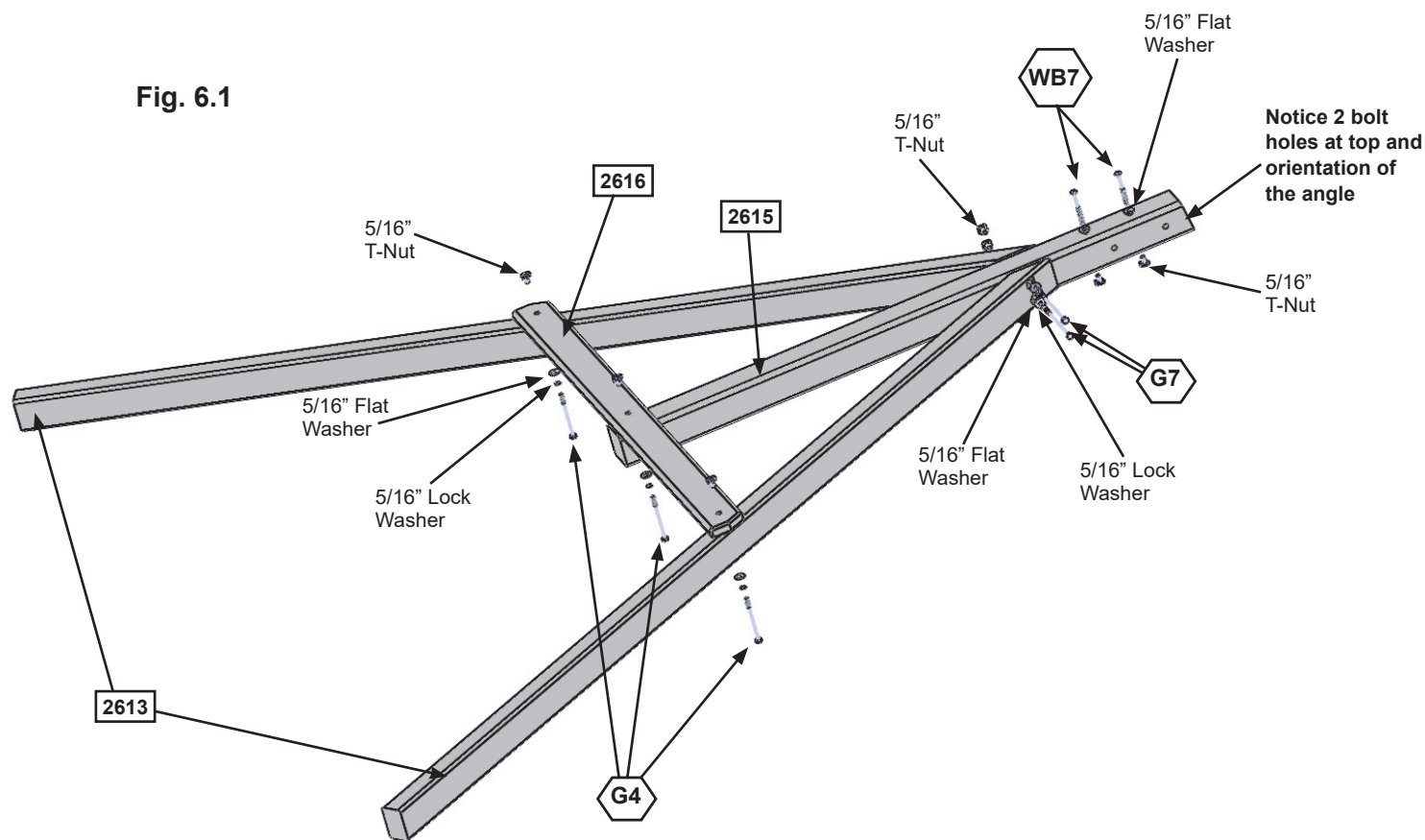


**A:** Loosely attach 2 (2613) Heavy SW Posts to (2615) SW Upright using 2 (G7) 5/16 x 5-1/2" Hex Bolts (with lock washer, flat washer and t-nut). Notice 2 bolt holes at top of (2615) SW Upright and orientation of angle. (fig. 6.1)

**B:** Attach (2616) SW Support to both (2613) Heavy SW Posts and (2615) SW Upright using 3 (G4) 5/16 x 4" Hex Bolts (with lock washer, flat washer and t-nut). Tighten all bolts (fig. 6.1)

**C:** Install 2 (WB7) 5/16 x 3" Wafer Bolts (with flat washer and t-nut) in the top bolt holes in (2615) SW Upright as shown in fig. 6.1. **IT IS IMPORTANT THAT THESE BOLTS ARE ATTACHED. THEY WILL MINIMIZE CHECKING OF WOOD.**

Fig. 6.1



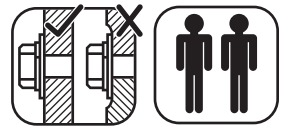
### Wood Parts

- 2 x 2613 Heavy SW Post 2 x 3 x 86-11/16"
- 1 x 2615 SW Upright 4 x 4 x 50-15/16"
- 1 x 2616 SW Support 5/4 x 4 x 46-1/2"

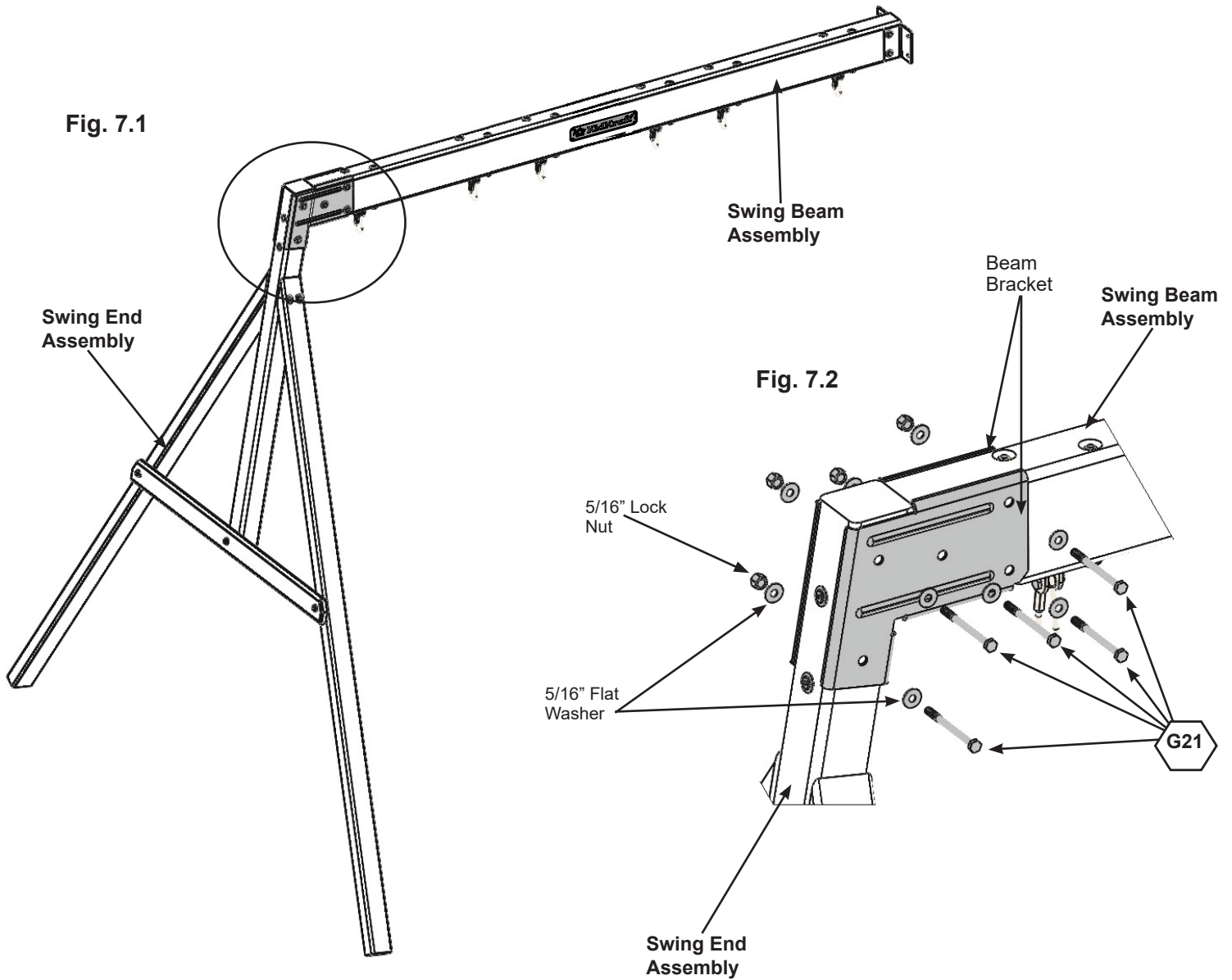
### Hardware

- 2 x G7 5/16 x 5-1/2" Hex Bolt (5/16" lock washer, 5/16" flat washer, 5/16" t-nut)
- 3 x G4 5/16 x 4" Hex Bolt (5/16" lock washer, 5/16" flat washer, 5/16" t-nut)
- 2 x WB7 5/16 x 3" Wafer Bolt (5/16" flat washer & 5/16" t-nut)

# Step 7: Attach Swing End to Swing Beam



**A:** Place Swing End Assembly against Swing Beam Assembly then place 1 Beam Bracket on each side of the assembly (they are specific for left and right side) and attach with 5 (G21) 5/16 x 3-3/4" Hex Bolts (with 2 flat washers and 1 lock nut). (fig. 7.1 and 7.2)



### Hardware

5 x  5/16 x 3-3/4" Hex Bolt  
(5/16" flat washer x 2, 5/16" lock nut)

### Other Parts

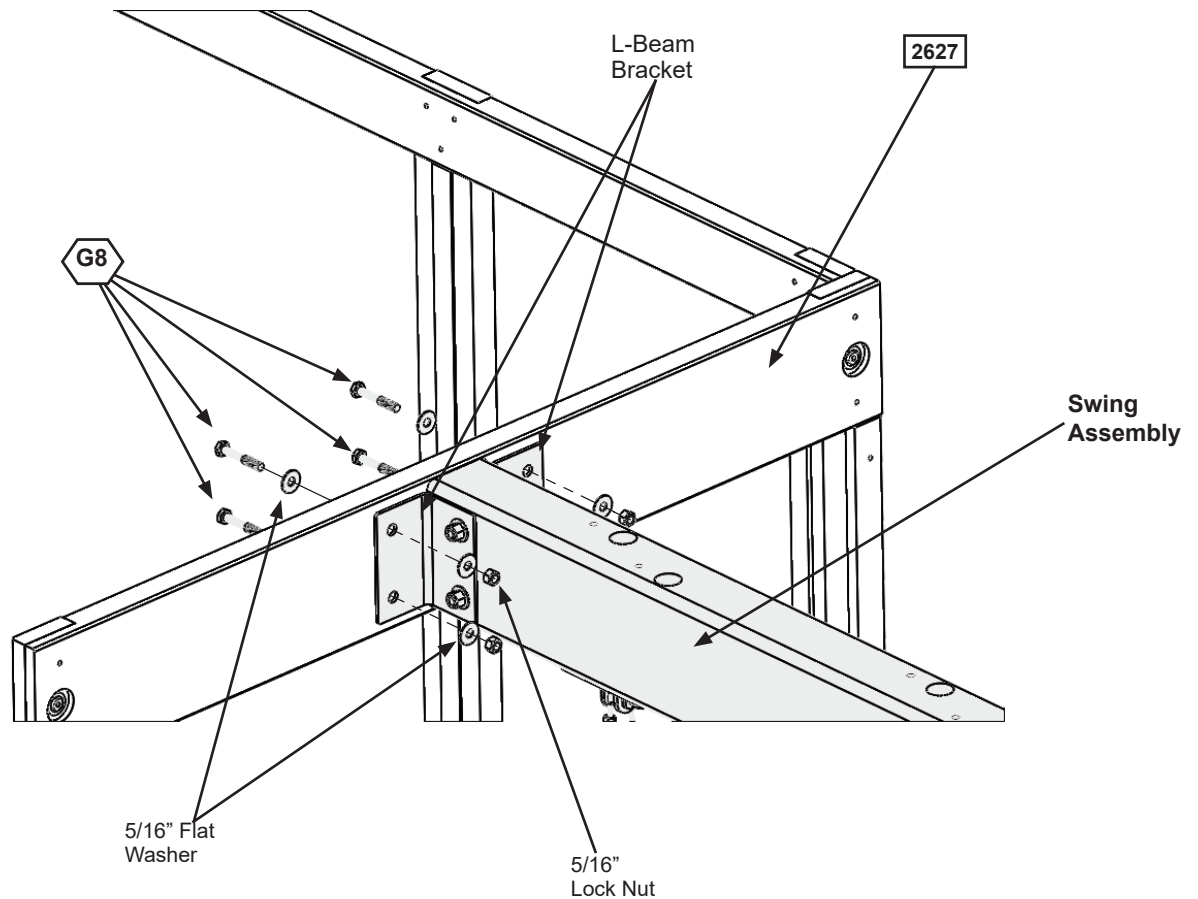
2 x Beam Bracket (Left/Right)

## Step 8: Attach Swing Assembly To Fort




**A:** Place Swing Assembly against top of (2627) SW Wall Panel, make sure assembly is level then attach from inside the fort assembly into each L-Beam Bracket with 4 (G8) 5/16 x 2" Hex Bolts (with 2 flat washers and 1 lock nut). (fig. 8.1)

Fig. 8.1



### Hardware

4 x  5/16 x 2" Hex Bolt  
(5/16" flat washer x 2, 5/16" lock nut)

## Step 9: Install Ground Stakes

### **MOVE FORT TO FINAL LOCATION PRIOR TO STAKING** **FINAL LOCATION MUST BE LEVEL GROUND**

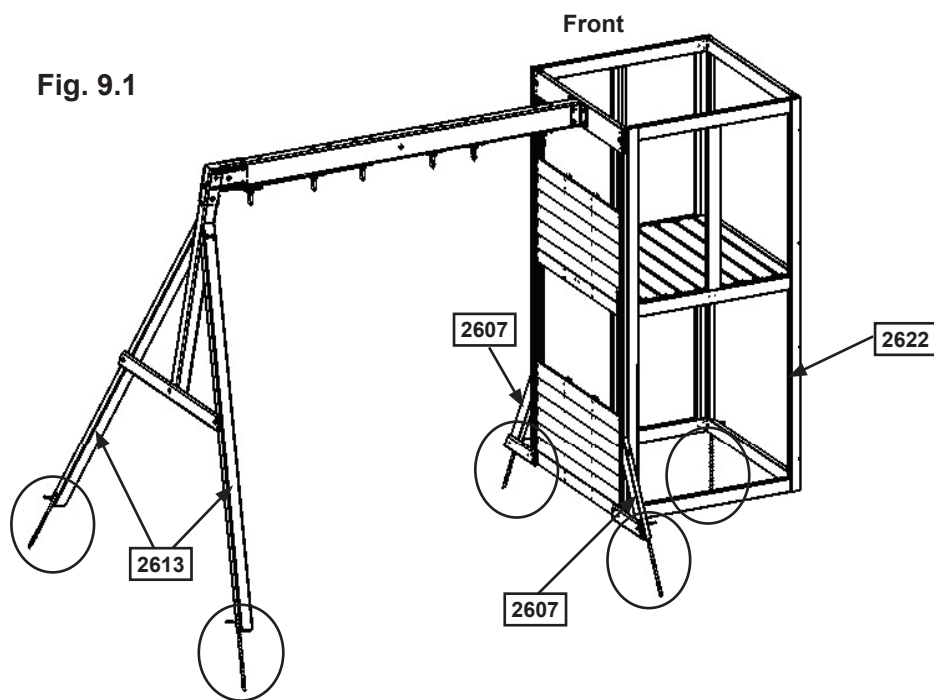
**A:** In the 5 places shown in fig. 9.1 drive the Rebar Ground Stakes 13" into the ground against outside front corner of (2622) End Panel Assembly, on both (2607) Diagonals and both (2613) Heavy SW Posts. Be careful not to hit the washer while hammering stakes into the ground as this could cause the washer to break off.

**B:** Attach ground stakes using 1 (S7) #12 x 2" Pan Screw per ground stake (fig. 9.2 and 9.3).

**C:** After driving stakes into the ground, check for sharp edges caused by the impact of the hammer. Smooth any sharp edges from impact area and touch up with outdoor paint.

**⚠ Warning!** To prevent tipping and avoid potential injury, stakes must be driven 13" into ground. Digging or driving stakes can be dangerous if you do not check first for under-ground wiring, cables or gas lines.

Fig. 9.1



**SEE FORT GUIDE SHEETS  
FOR SAFETY CLEARANCE  
AND FORT ORIENTATION**

Fig. 9.2

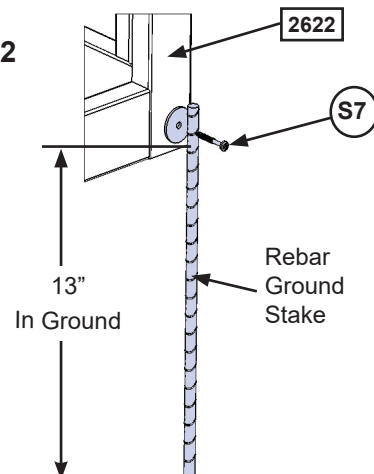
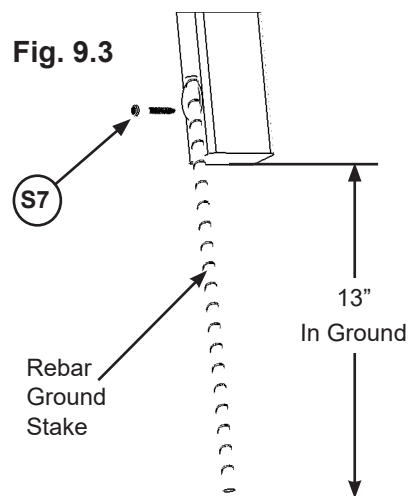


Fig. 9.3



#### Hardware

5 x (S7) #12 x 2" Pan Screw

#### Other Parts

5 x Rebar Ground Stake

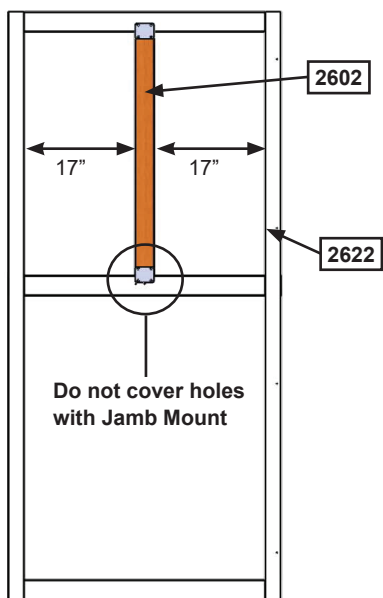
# Step 10: Install Upper and Lower Jambs



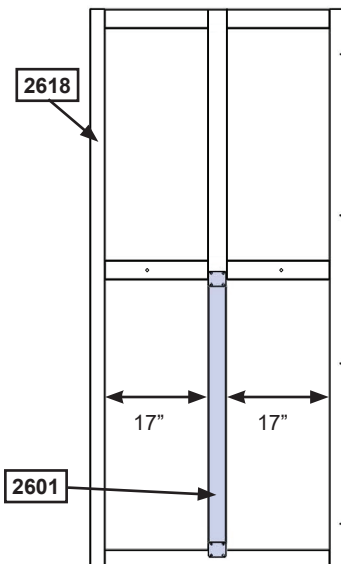
**A:** In the upper opening of (2622) End Panel Assembly place 1 (2602) Upper Jamb so it measures 17" to the inside of each post then attach with 2 Jamb Mounts using 4 (S0) #8 x 7/8" Truss Screws per mount. (fig. 10.1, 10.4, 10.5 and 10.6)

**B:** In the lower opening of each (2618) Front Back Panel place 1 (2601) Lower Jamb so it measures 17" to the inside of each post then attach each (2601) Lower Jamb with 2 Jamb Mounts using 4 (S0) #8 x 7/8" Truss Screws per mount. (fig. 10.2, 10.3, 10.4, 10.5 & 10.6).

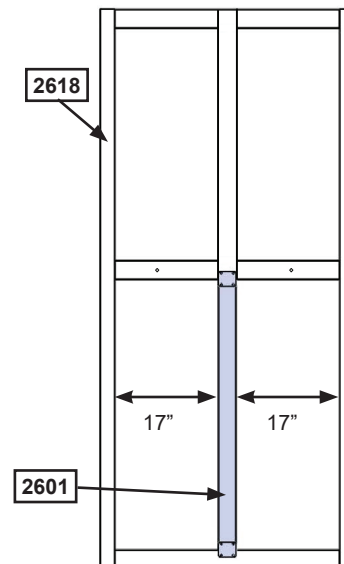
**Fig. 10.1**  
Side View



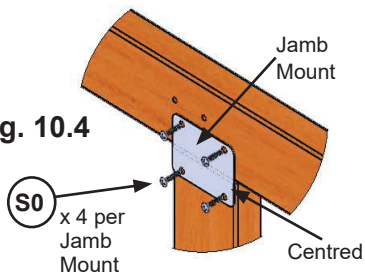
**Fig. 10.2**  
Front View



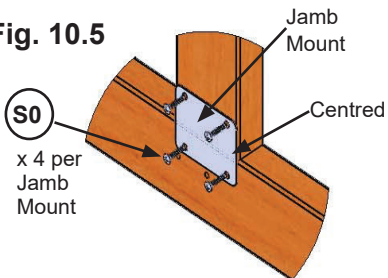
**Fig. 10.3**  
Back View



**Fig. 10.4**

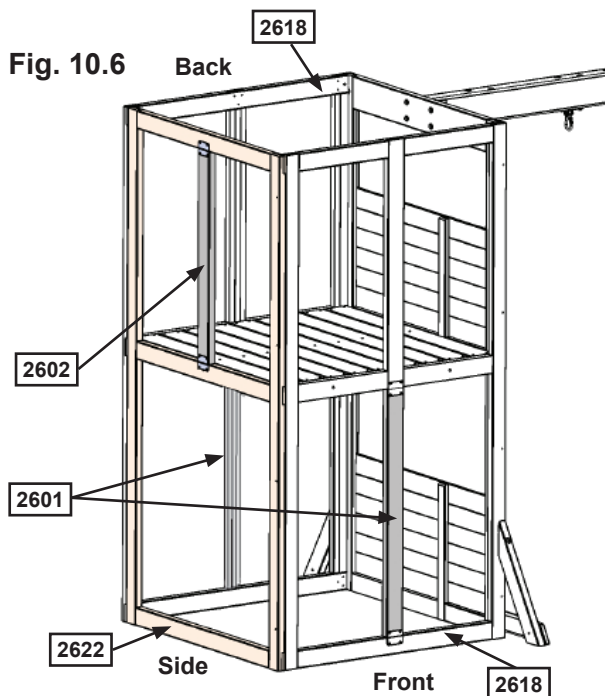


**Fig. 10.5**



Grooves to the inside

**Fig. 10.6**



### Wood Parts

- 1 x 2602 Upper Jamb 1-1/4 x 3 x 35-15/16"
- 2 x 2601 Lower Jamb 1-1/4 x 3 x 41-15/16"

### Hardware

- 24 x S0 #8 x 7/8" Truss Screw

### Other Parts

- 6 x Jamb Mount

# Step 11: Install Window and Wall Inserts

## Part 1 - Front Wall

**A:** In the places shown in fig. 11.1 and 11.2, on the Front of the assembly install 1 (2719) Upper Window Insert in the upper openings of (2618) Front Back Panel and 1 (2720) Lower Window Insert in the lower right opening of (2618) Front Back Panel using 9 (S0) #8 x 7/8" Truss Screws per insert. (fig. 11.1, 11.2 and 11.3)

**B:** In the upper openings of the front (2618) Front Back Panel install 1 MOD 3-Pane Transoms with 4 (S0) #8 x 7/8" Truss Screws. (fig. 11.1, 11.2 and 11.4)

Fig. 11.1

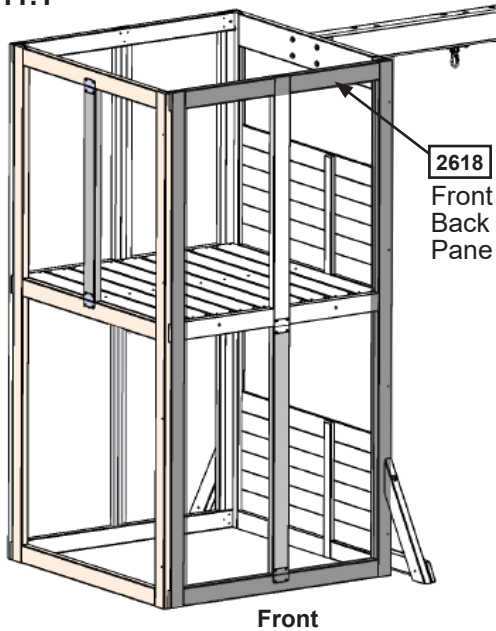


Fig. 11.2

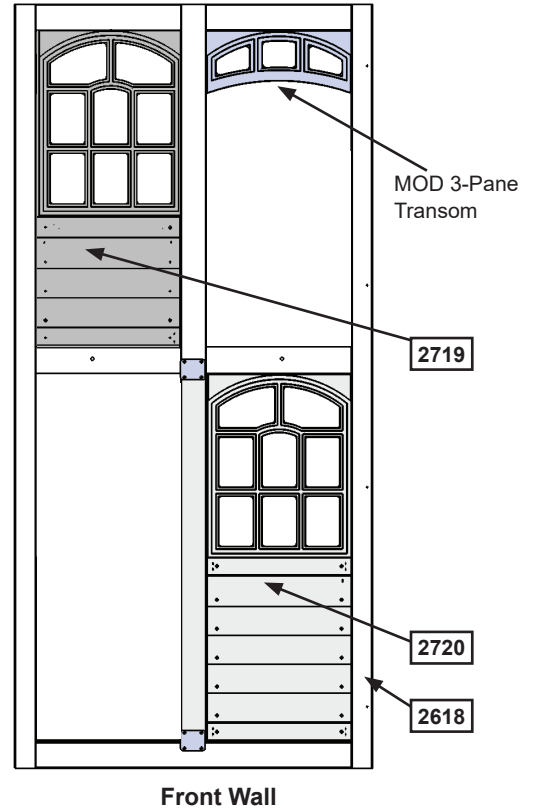


Fig. 11.3  
Inside View

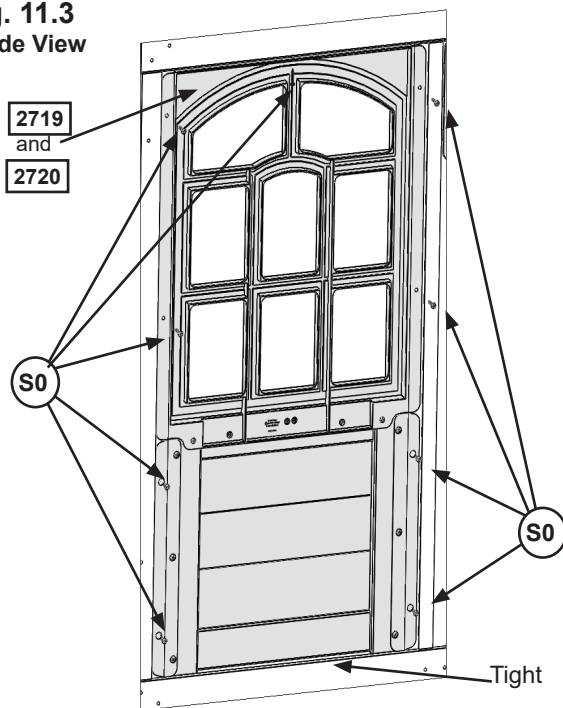
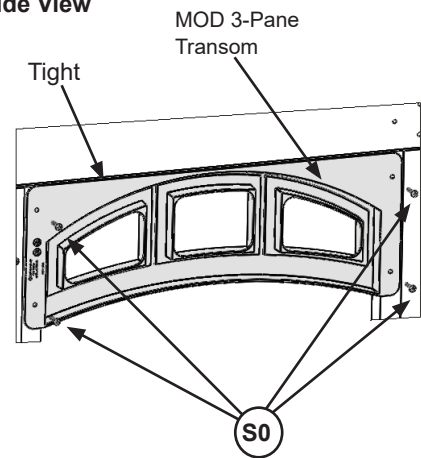


Fig. 11.4  
Inside View



### Wood Parts

- 1 x 2719 Upper Window Insert 1.27 x 18.8 x 35.86"
- 1 x 2720 Lower Window Insert 1.27 x 18.8 x 41.91"

### Hardware

- 22 x S0 #8 x 7/8" Truss Screw

### Other Parts

- 1 x MOD 3-Pane Transom

# Step 11: Install Window and Wall Inserts

## Part 2 - Left Side Wall

**C:** In the places shown in fig. 11.5 and 11.6, on the Left Side of the assembly install 1 (2719) Upper Window Inserts in the upper openings of (2622) End Panel Assembly with 9 (S0) #8 x 7/8" Truss Screws per insert and 1 (2665) Half Wall Insert in the lower opening using 4 (S0) #8 x 7/8" Truss Screws. (fig. 11.5, 11.6, 11.7 and 11.8)

**D:** In the upper openings of (2622) End Panel Assembly install 1 MOD 3-Pane Transoms with 4 (S0) #8 x 7/8" Truss Screws. (fig. 11.5, 11.6 and 11.9)

Fig. 11.5

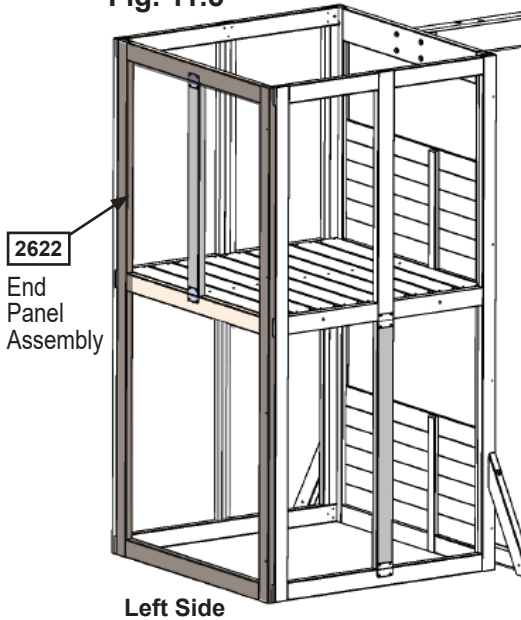


Fig. 11.6

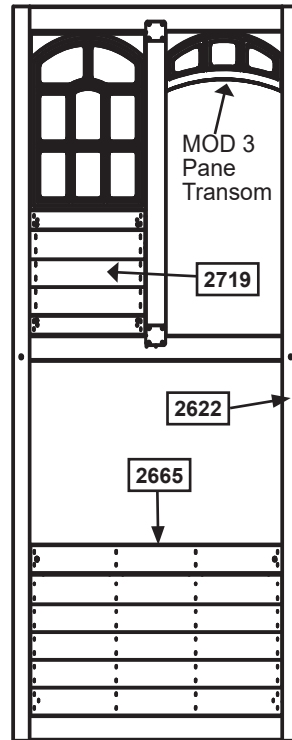


Fig. 11.7  
Inside View

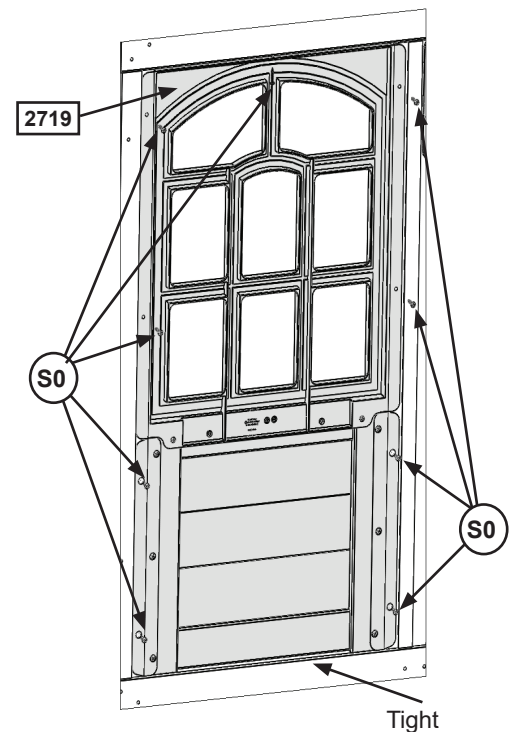


Fig. 11.8  
Inside View

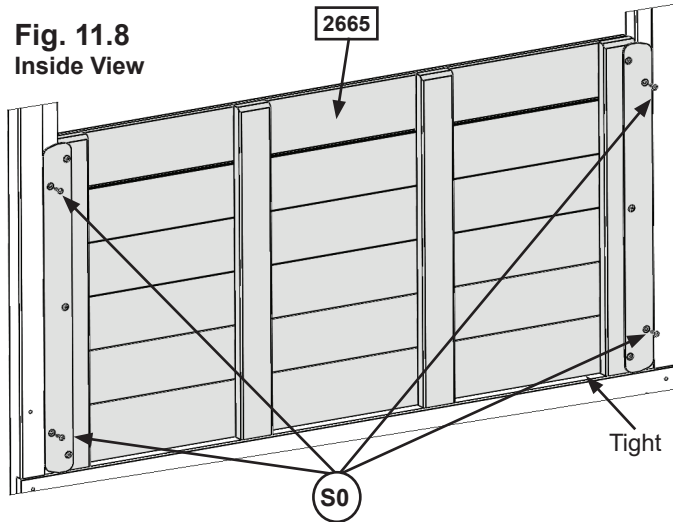
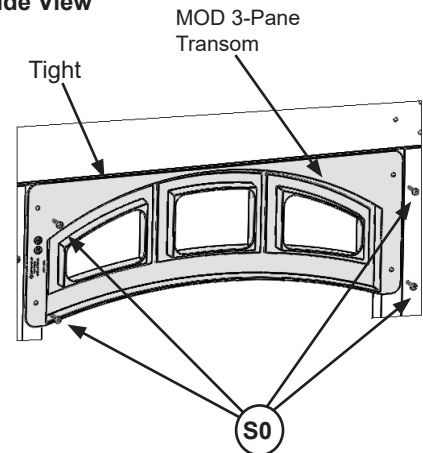


Fig. 11.9  
Inside View



### Wood Parts

- 1 x 2719 Upper Window Insert 1.27 x 18.8 x 35.86"
- 1 x 2665 Half Wall Insert 1.4 x 20-1/4 x 38.8"

### Hardware

- 17 x S0 #8 x 7/8" Truss Screw

### Other Parts

- 1 x MOD 3-Pane Transom

# Step 11: Install Window and Wall Inserts

## Part 3 - Back Wall

**E:** On the (2618) Front Back Panel on the Back of the assembly, install 2 (649A) Short Half Wall in the upper opening using 4 (S0) #8 x 7/8" Truss Screws per wall. (fig. 11.10 and 11.11 and 11.13)

**F:** In the lower openings of the back (2618) Front Back Panel install 1 (2720) Lower Window Insert with 9 (S0) #8 x 7/8" Truss Screws. (fig. 11.10, 11.11 and 11.12)

Fig. 11.10

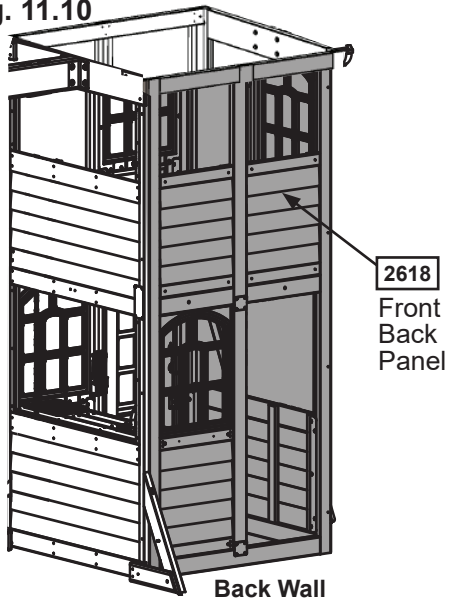


Fig. 11.11

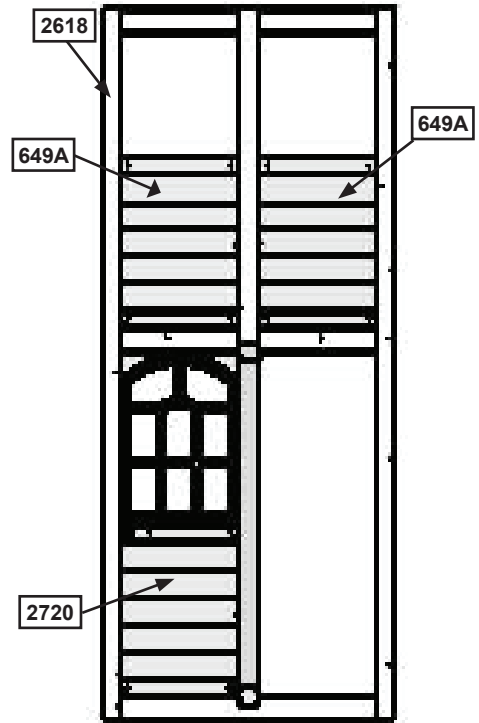


Fig. 11.12  
Inside View

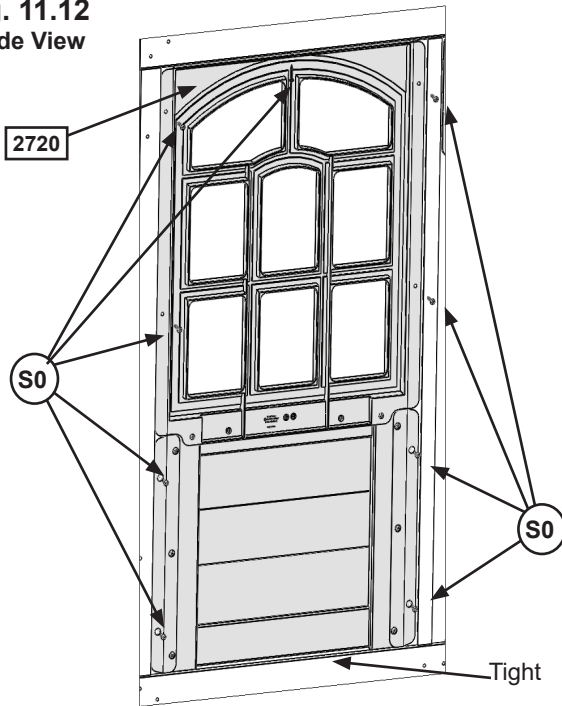
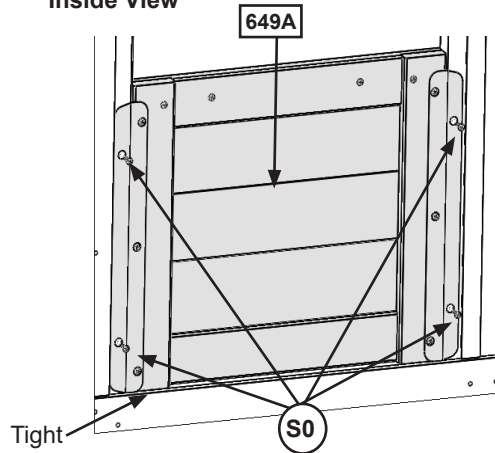


Fig. 11.13  
Inside View



### Wood Parts

- 2 x (649A) Short Half Wall 1.27 x 18.8 x 20-15/16"
- 1 x (2720) Lower Window Insert 1.27 x 18.8 x 41.91"

### Hardware

- 17 x (S0) #8 x 7/8" Truss Screw

# Step 12: Clock Assembly

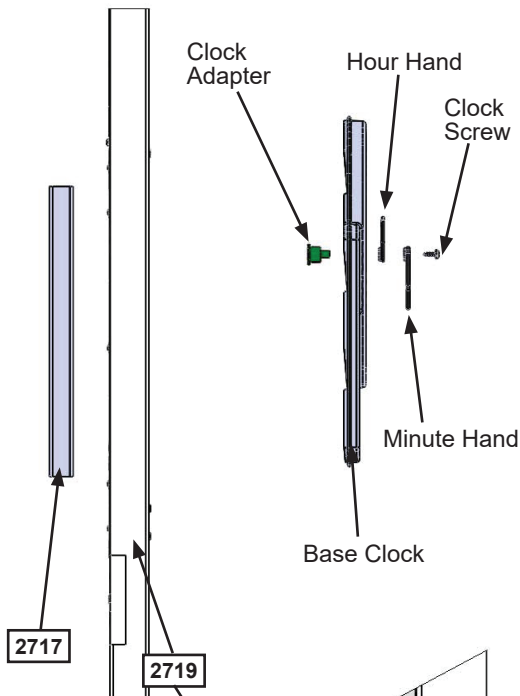


**A:** From the back of the Base Clock insert the Clock Adapter then from the front of the Base Clock place the Hour Hand over the Clock Adapter making sure they line up properly. Press the Minute Hand over the Hour Hand and connect with the Clock Screw. (fig. 12.1)

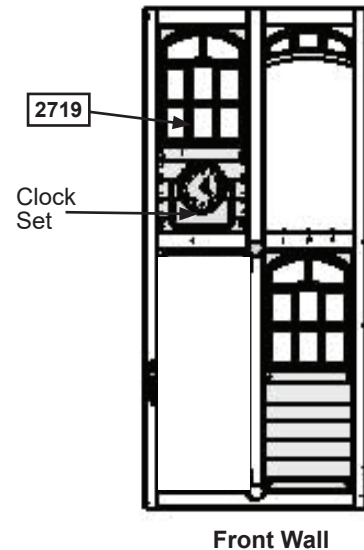
**B:** On the Front of the Assembly place Clock Assembly centred under window of (2719) Upper Window Insert. Then with a helper attach to (2719) Upper Window Insert and into each (2717) Clock Block with 2 (S2) #8 x 1-1/2" Wood Screws per block. (fig. 12.2, 12.3 and 12.4)

**Do not over tighten screws.**

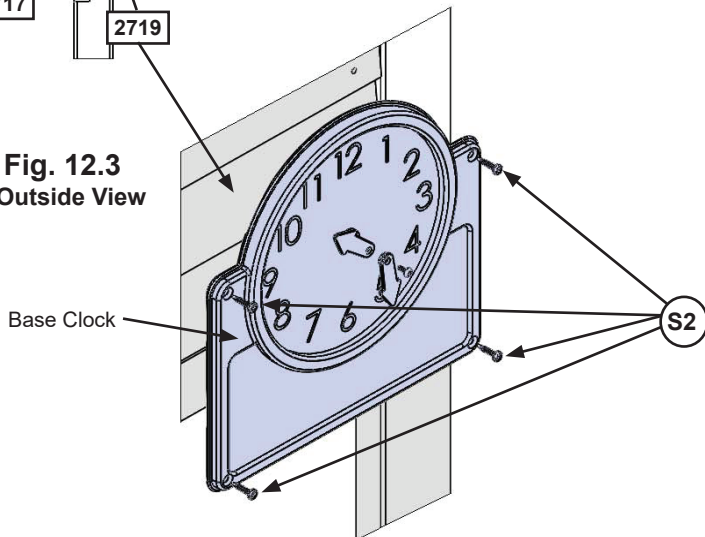
**Fig. 12.1**  
Side View



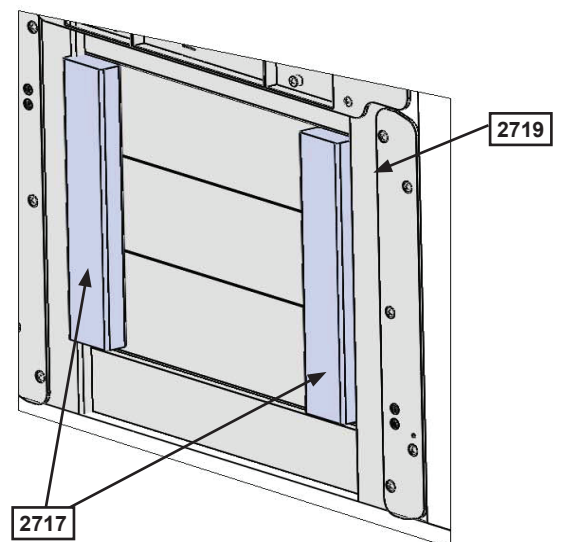
**Fig. 12.2**



**Fig. 12.3**  
Outside View



**Fig. 12.4**  
Inside View



**Wood Parts**

2 x 2717 Clock Block 3/4 x 1-3/4 x 9-3/4"

**Hardware**

4 x S2 #8 x 1-1/2" Wood Screw

**Other Parts**

- 1 x Base Clock
- 1 x Clock Subset
  - 1 x Clock Adapter
  - 1 x Hour Hand
  - 1 x Minute Hand
  - 1 x Clock Screw



# Step 14: Attach Rock Wall Assembly to Fort

## Part 1

**A:** Place Rock Wall Assembly in opening shown fig.14.1 and flush as shown below. Attach (0349) Rock Rails to panel using 4 (S11) #8 x 2" Wood Screws. (fig. 14.1, 14.2, 14,3)

**B:** Attach 1 (2605) Access Board to top of Rock Wall Assembly, flush to top of (0349) Rock Rail using 4 (S20) #8 x 1-3/8" Wood Screws. (fig. 14.4)

Fig. 14.1

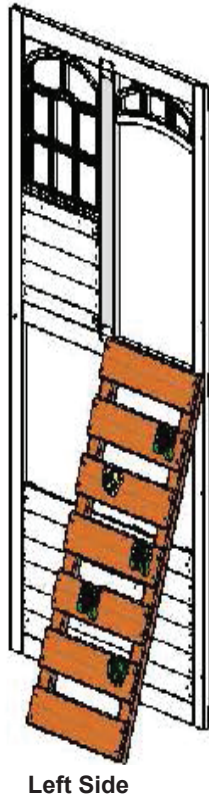


Fig. 14.2

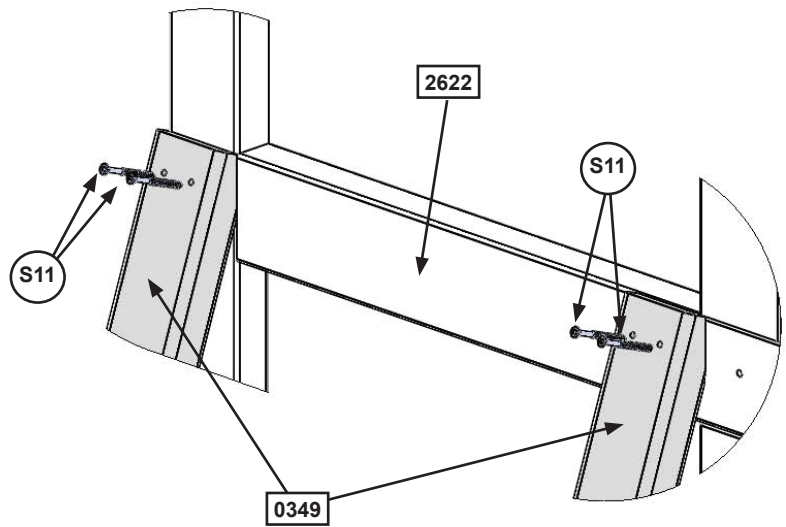


Fig. 14.3

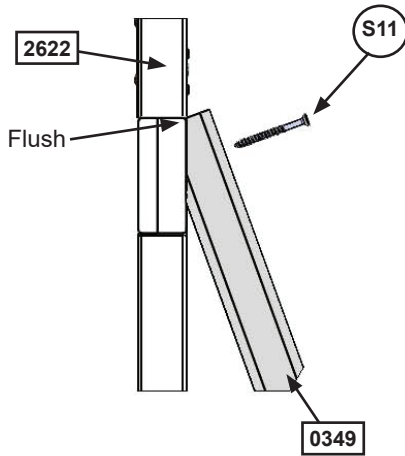
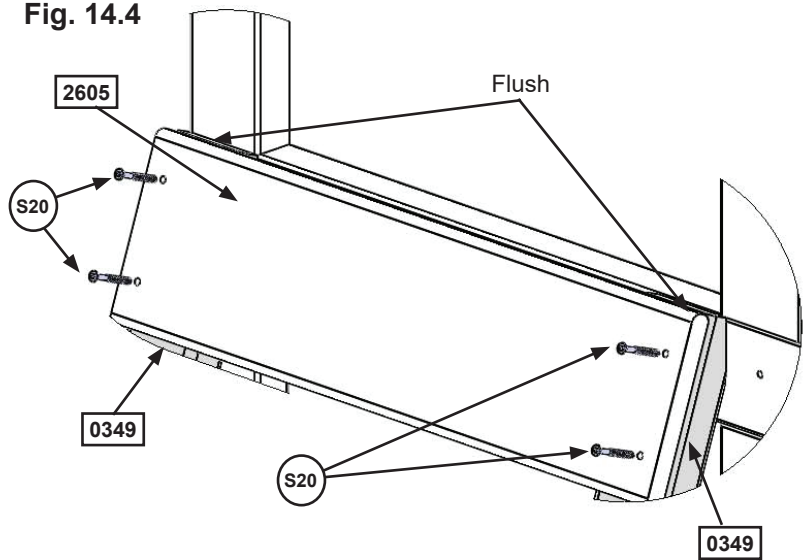


Fig. 14.4



### Wood Parts

1 x [2605] Access Board 1 x 6 x 19-3/4"

### Hardware

4 x (S20) #8 x 1-3/8" Wood Screw

4 x (S11) #8 x 2" Wood Screw

# Step 14: Attach Rock Wall Assembly to Fort

## Part 2

**C:** Drive 1 Rebar Ground Stake 13" into the ground against outside (0349) Rock Rail then attach with 1 (S7) #12 x 2" Pan Screw. Be careful not to hit the washer while hammering stake into the ground as this could cause the washer to break off. (fig. 14.4 and 14.5)

**D:** After driving stake into the ground, check for sharp edges caused by the impact of the hammer. Smooth any sharp edges from impact area and touch up with outdoor paint.

**⚠Warning!** To prevent tipping and avoid potential injury, stakes must be driven 13" into ground. Digging or driving stakes can be dangerous if you do not check first for under-ground wiring, cables or gas lines.

Fig. 14.4

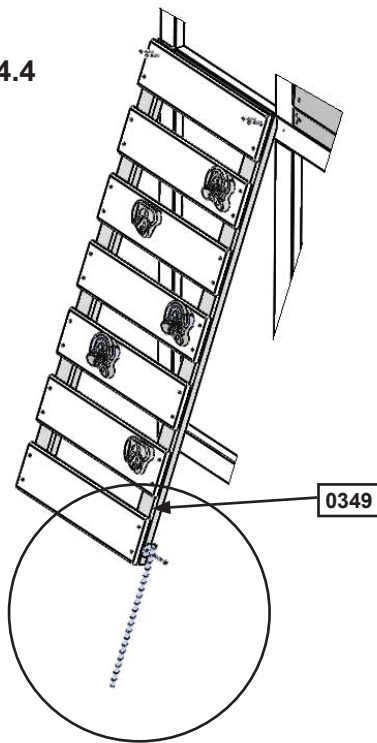
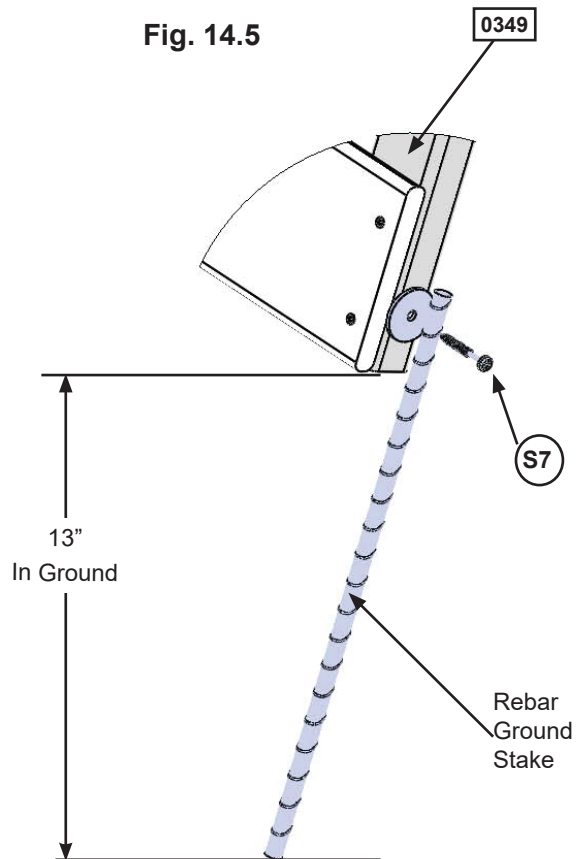


Fig. 14.5



### Hardware

1 x (S7) #12 x 2" Pan Screw

### Other Parts

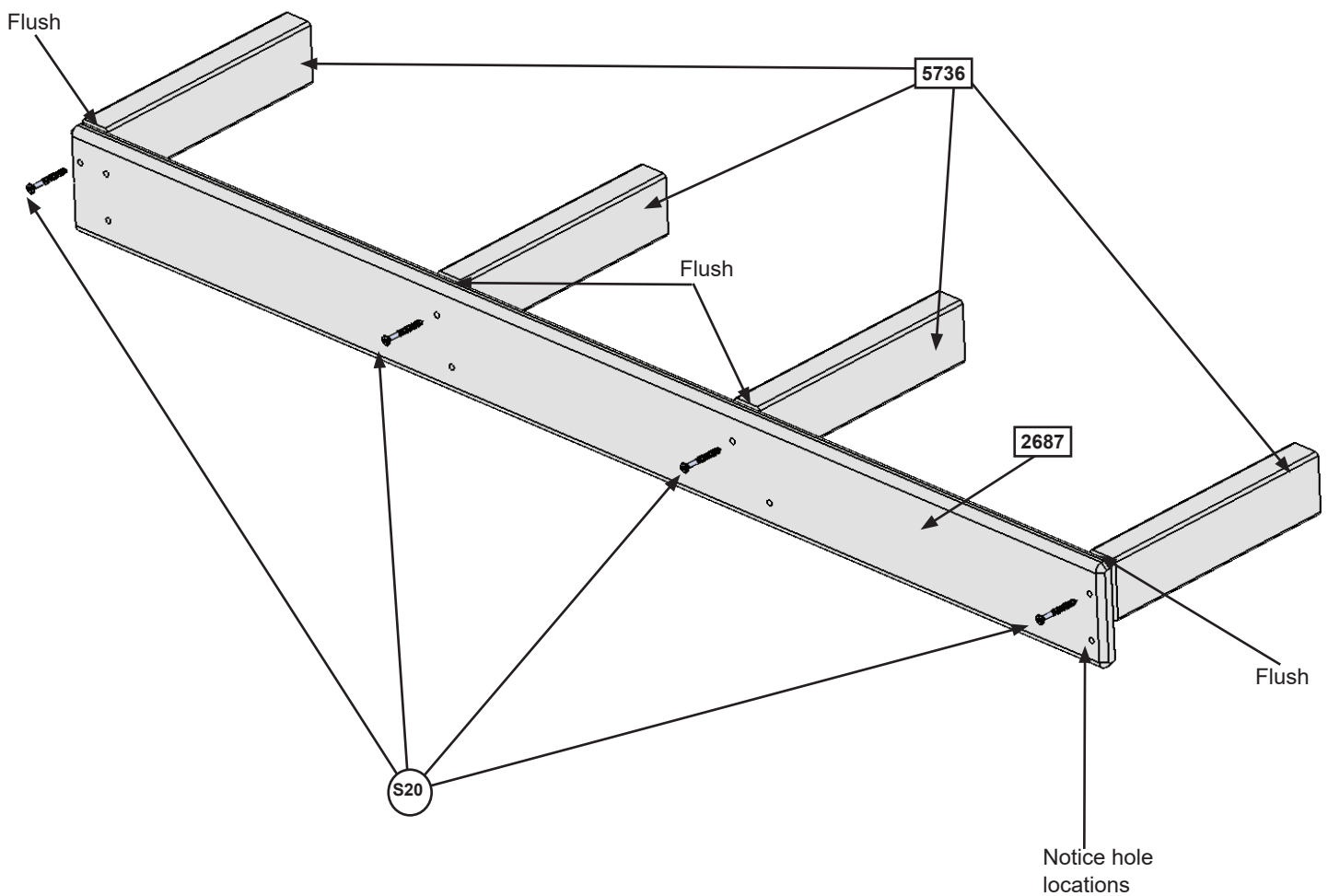
1 x Rebar Ground Stake

# Step 15: Counter Assembly Part 1

**A:** Flush to each end and to the top of (2687) Counter Back attach 1 (5736) Counter Joist per end with 1 (S20) #8 x 1-3/8" Wood Screw per joist. Notice the remaining holes at the bottom of (2687) Counter Back. (fig. 15.1)

**B:** Place the remaining 2 (5736) Counter Joists centred over the pilot holes in the middle of (2687) Counter Back and flush to the top of the board, then attach, in the top holes, with 1 (S20) #8 x 1-3/8" Wood Screw per joist. (fig. 15.1)

Fig. 15.1



### Wood Parts

- 1 x 2687 Counter Back 1 x 4 x 40-5/8"
- 4 x 5736 Counter Joist 1 x 2 x 8-1/4"

### Hardware

- 4 x S20 #8 x 1-3/8" Wood Screw

# Step 15: Counter Assembly Part 2

C: On the inside of the panel shown in Fig 15.2, place Counter Assembly so the top of (2687) Counter Back is flush to the top of the opening then attach with 5 (S20) #8 x 1-3/8" Wood Screws. (fig. 15.2 and 15.3)

Fig. 15.2  
Outside View

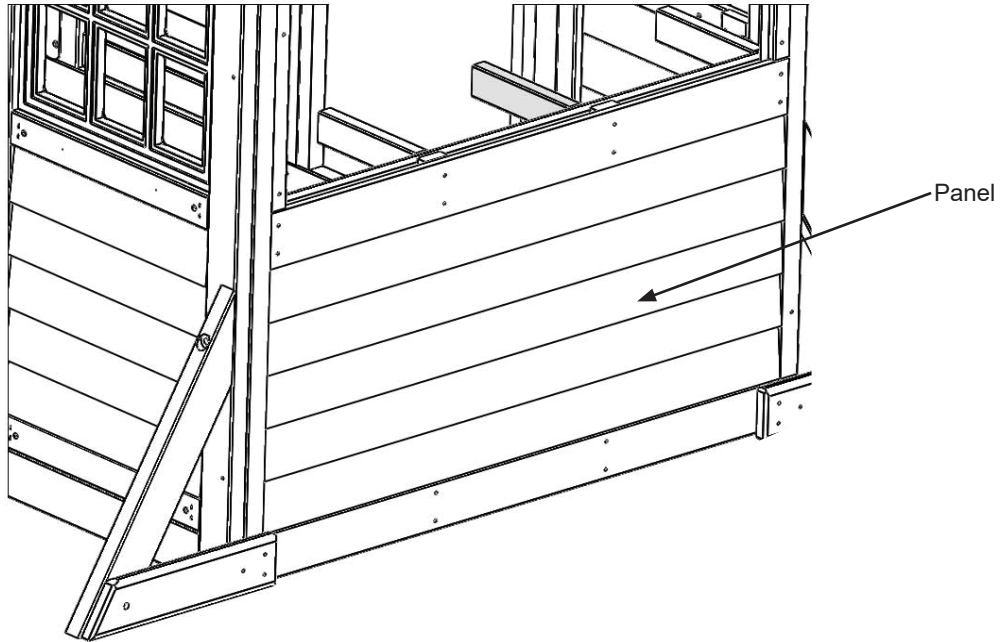
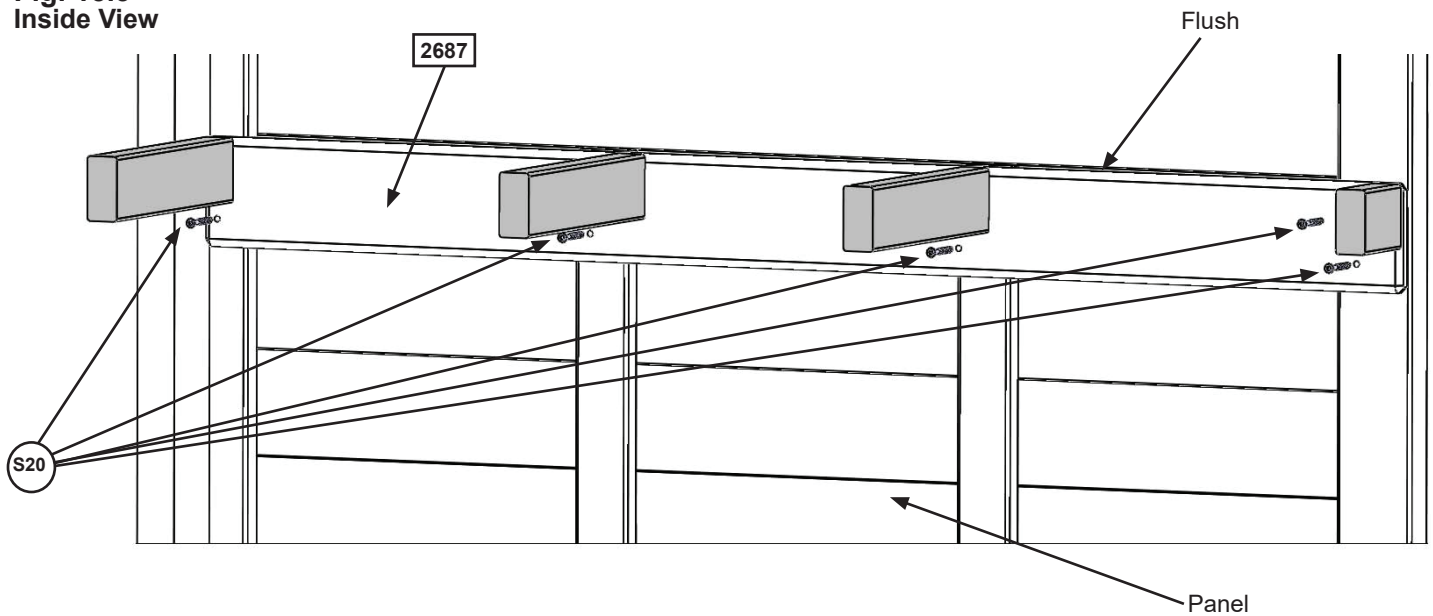


Fig. 15.3  
Inside View



## Hardware

5 x (S20) #8 x 1-3/8" Wood Screw

# Step 15: Counter Assembly

## Part 3

D: Place 1 (6136) Counter Brace flush to the front and outside edge of each outer (5736) Counter Joist and tight to the panel then attach with 2 (S3) #8 x 2-1/2" Wood Screws per brace. (fig. 15.4 and 15.5)

Fig. 15.4

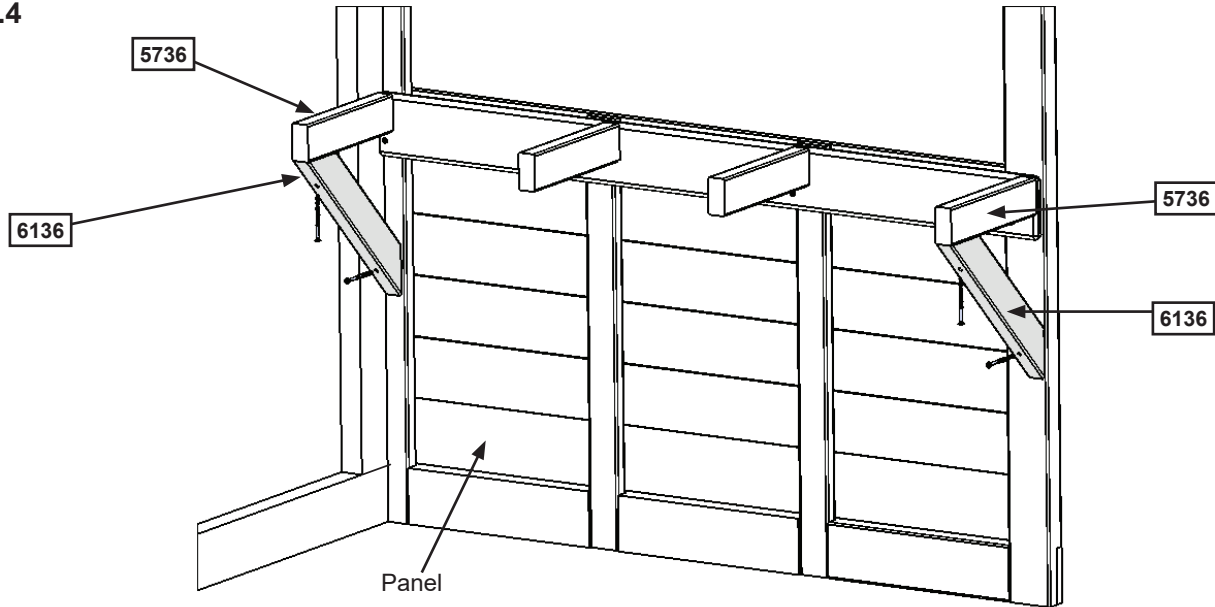
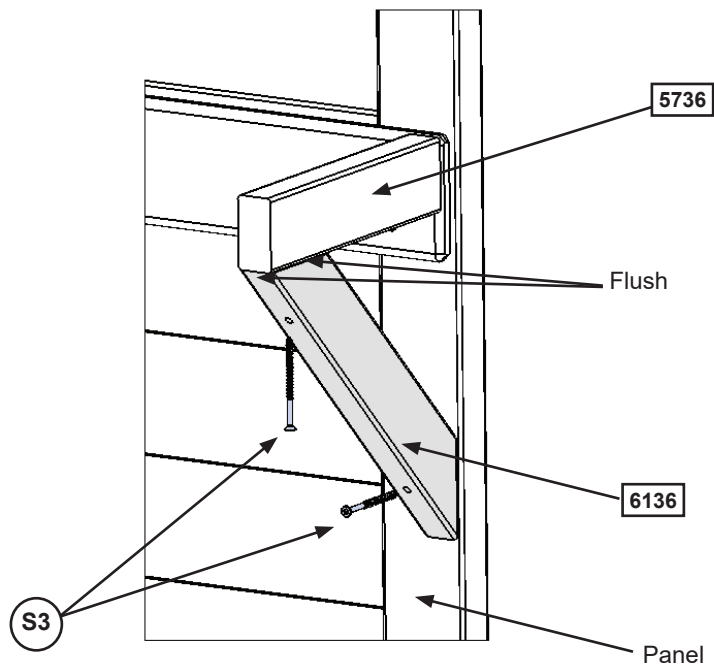


Fig. 15.5



### Wood Parts

2 x 6136 Counter Brace 1 x 2 x 12-9/16"

### Hardware

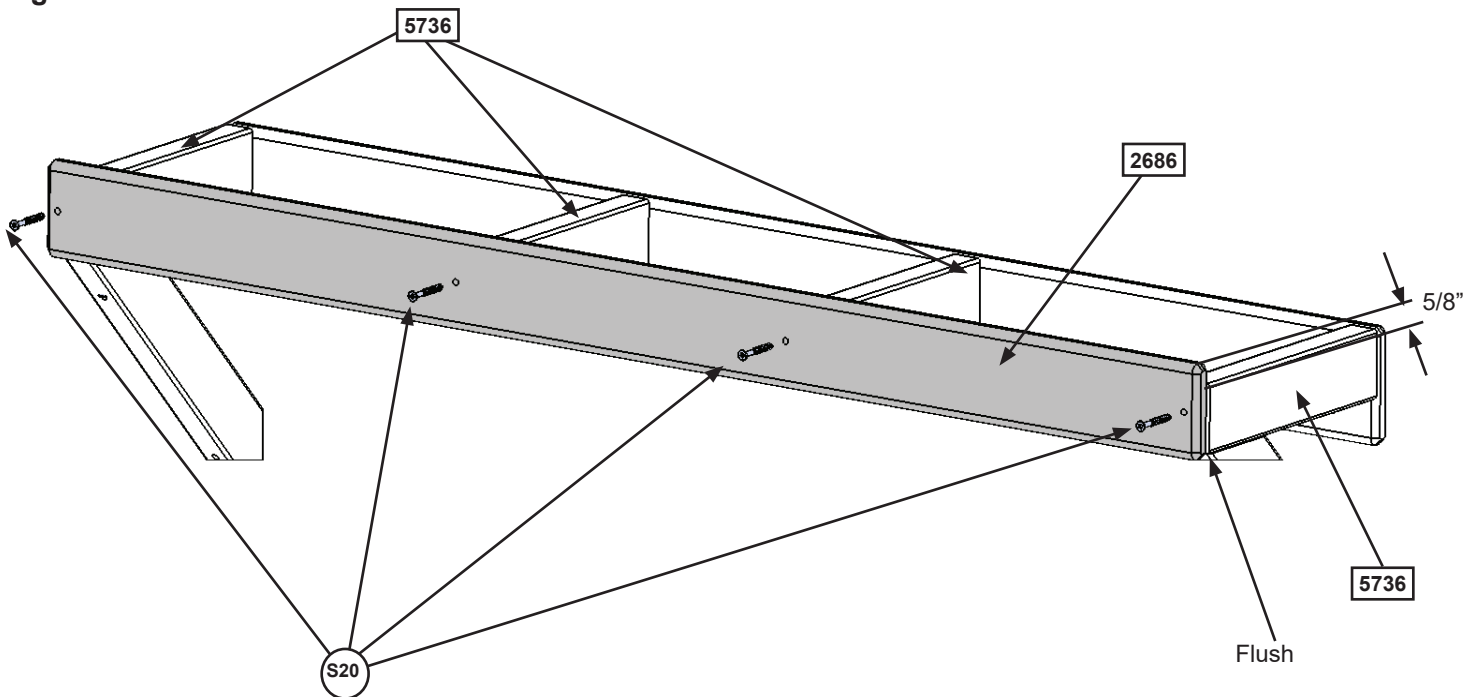
4 x S3 #8 x 2-1/2" Wood Screw

# Step 15: Counter Assembly Part 4



**E:** Place (2686) Counter Front against (5736) Counter Joists so the ends are flush and the centre (5736) Counter Joists are centred over the pilot holes. Measure 5/8" down from the top of (2686) Counter Front on both ends and attach to the (5736) Counter Joists with 4 (S20) #8 X 1-3/8" Wood Screws. (fig. 15.6)

Fig. 15.6



### Wood Parts

1 x **2686** Counter Front 5/8 x 2-3/4 x 40-5/8"

### Hardware

4 x **S20** #8 x 1-3/8" Wood Screw

# Step 15: Counter Assembly Part 5

**F:** Tight to (2687) Counter Back attach (2685) Counter Top to each (5736) Counter Joist with 4 (TS) #6 x 30 mm Trim Screws. (fig. 15.7)

**G:** Tight to (2685) Counter Top and flush to the outside edges of the outer (5736) Counter Joists attach 1 (5536) Counter Side per joist with 3 (TS) #6 x 30 mm Trim Screws per board. (fig. 15.7)

**H:** Tight to (2685) Counter Top and centred over the middle 2 (5736) Counter Joists with ends flush to the outside edges attach 2 (2716) Counter Mid Tops with 4 (TS) #6 x 30 mm Trim Screws per board. (fig. 15.7)

**I:** Attach (2685) Counter Top to the panel with 2 (TS) #6 x 30 mm Trim Screws per board. (fig. 15.8)

Fig. 15.7

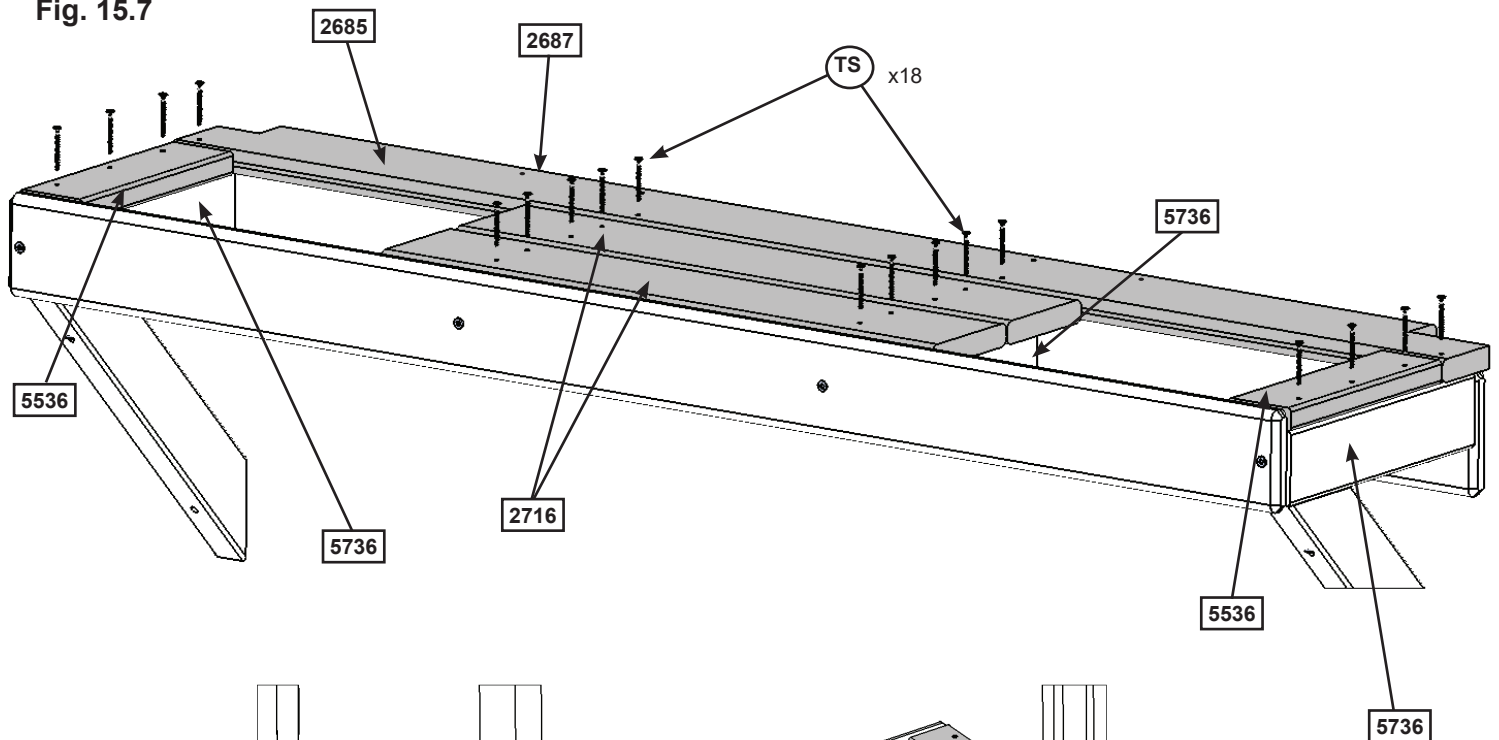
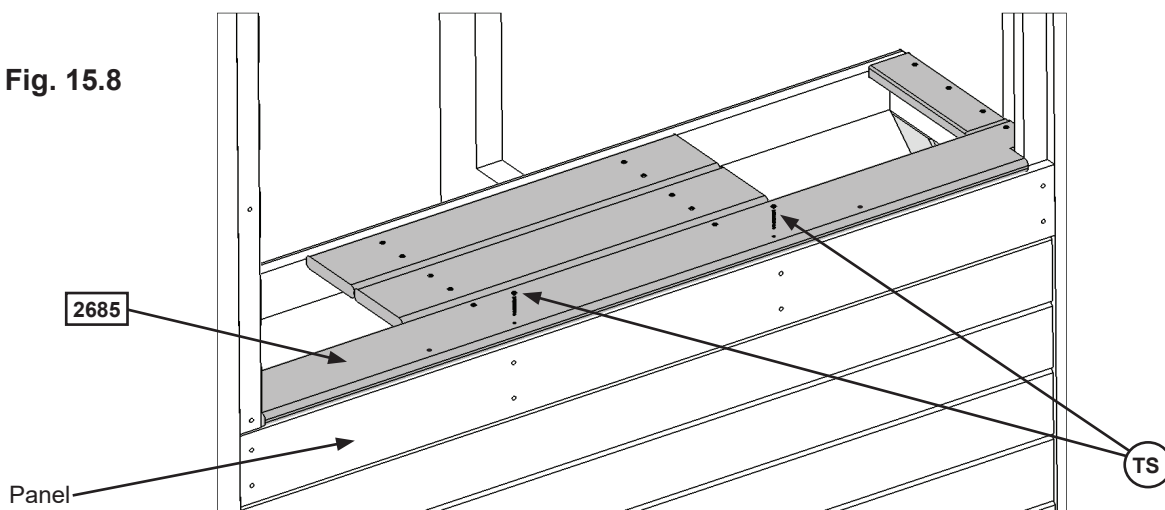


Fig. 15.8



## Wood Parts

- 2 x 2716 Counter Mid Top 1 x 4 x 17-5/8"
- 1 x 2685 Counter Top 1 x 4 x 40-5/8"
- 2 x 5536 Counter Side 5/8 x 2 x 6-3/4"

## Hardware

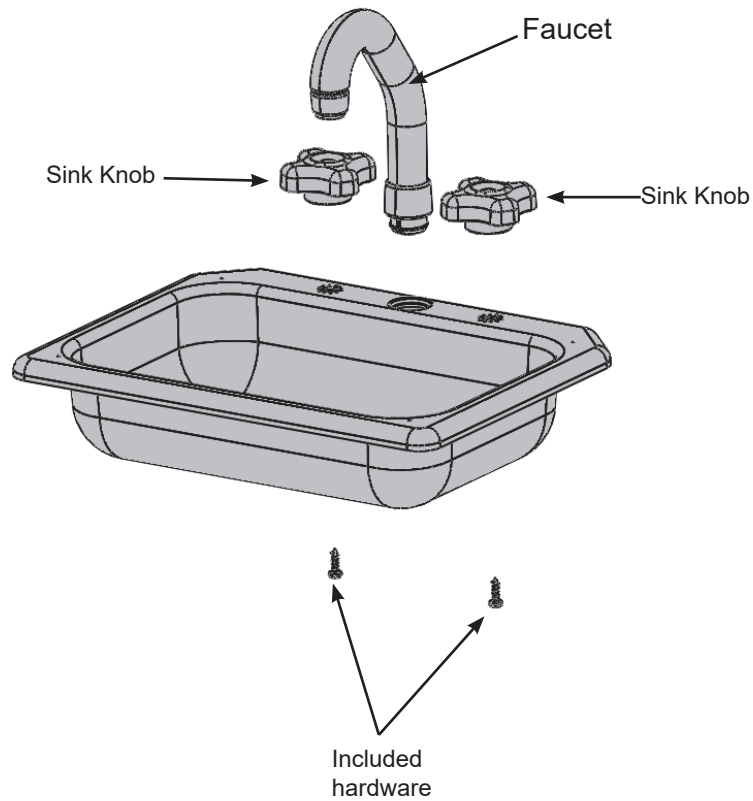
- 20 x TS #6 x 30 mm Trim Screw

# Step 15: Counter Assembly Part 6

J: Place Faucet and 2 Sink Knobs in opening of Sink and attach Sink Knobs with included hardware. (fig. 15.9)

**Important: Use a hand held screw driver and DO NOT over tighten.**

Fig. 15.9



### Other Parts

1 x Sink  
2 x Sink Knobs  
1 x Faucet

# Step 15: Counter Assembly Part 7

**K:** Place Sink and Stove in the openings of the Counter Assembly then attach 4 Mount Clips with included hardware to the bottom of the Sink and Stove to secure in place. (fig. 15.10 and 15.11)

**Important:** Use a hand held screw driver and **DO NOT** over tighten.

Note: To remove the Sink or Stove loosen screw 1/4 turn then twist Mount Clips.

Fig. 15.10

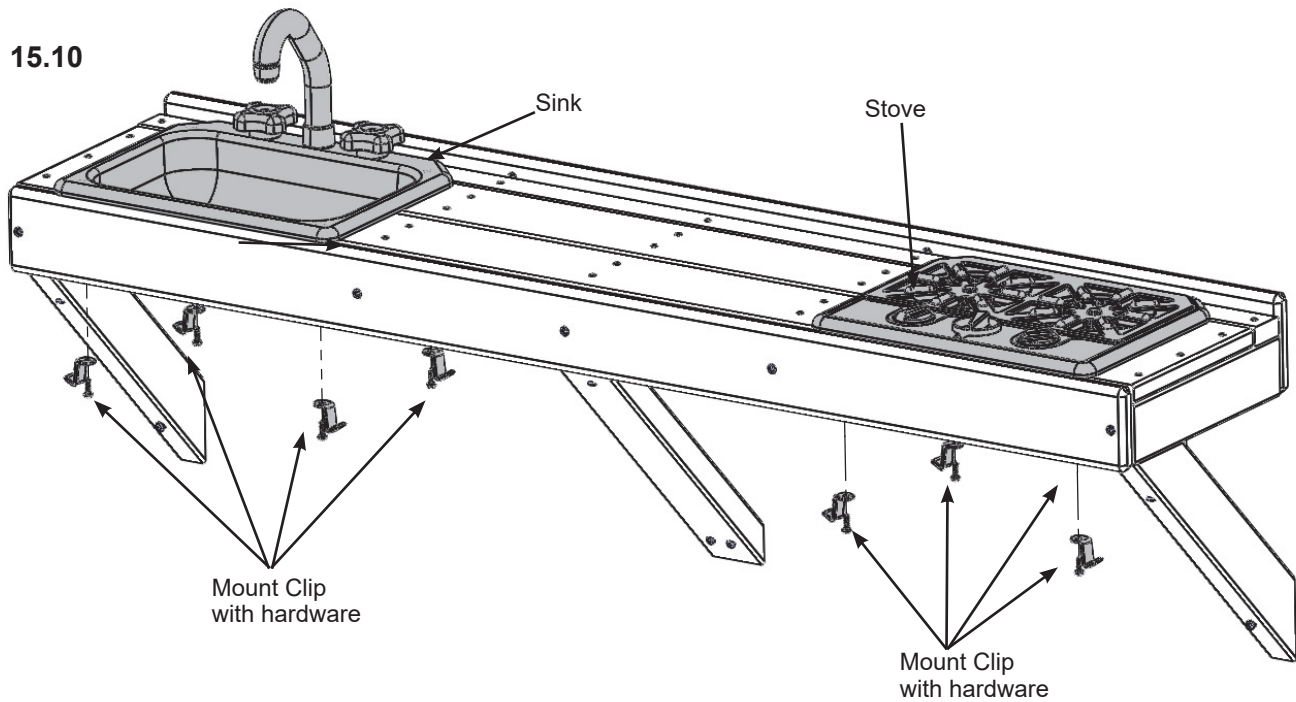
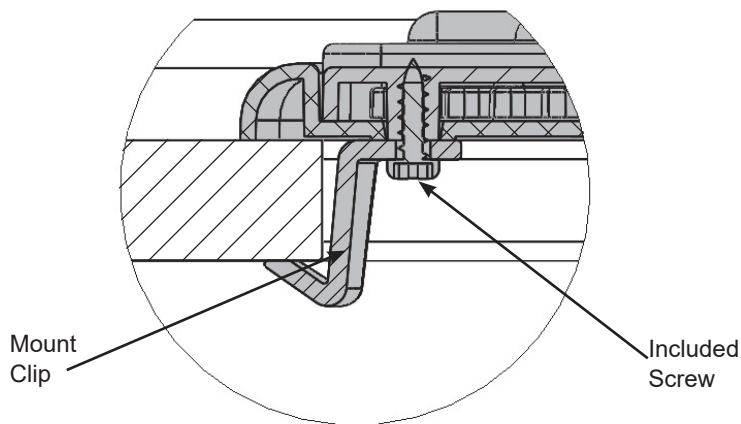


Fig. 15.11



### Other Parts

1 x Stove  
8 x Mount Clip

# Step 16: Attach Utensil Shelf

**A:** From inside the assembly, centred in the top of the opening of panel as shown in Fig. 16.1, above the counter, attach Utensil Shelf with 2 (S13) #6 x 5/8" Pan Screws as shown in fig. 16.1 and 16.2.

**B:** Attach Pot, Pan and Spatula to the Utensil Shelf. (fig. 16.1)

Fig. 16.1

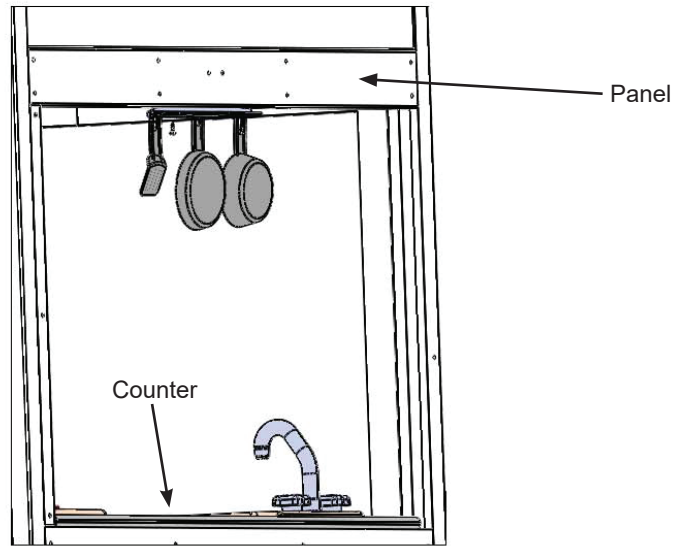
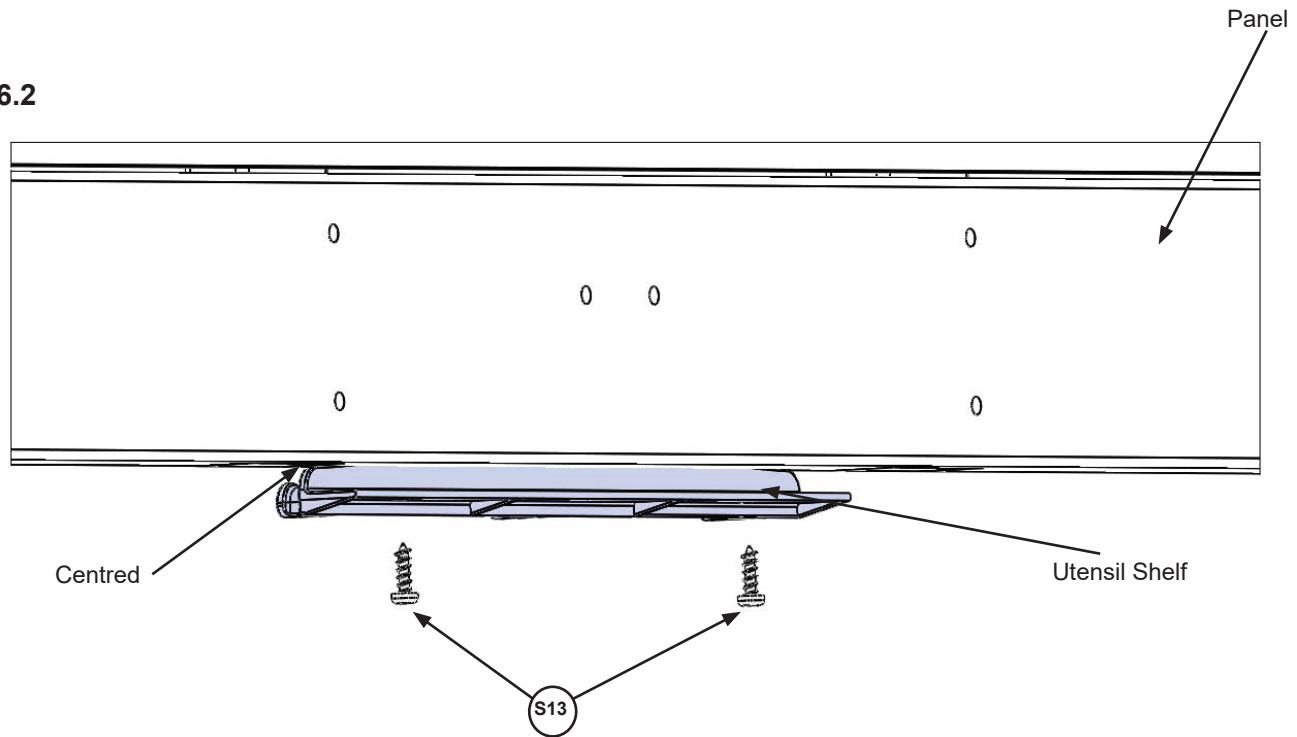


Fig. 16.2



### Hardware

2 x (S13) #6 x 5/8" Pan Screw

### Other Parts

1 x Utensil Shelf  
1 x Pot  
1 x Pan  
1 x Spatula

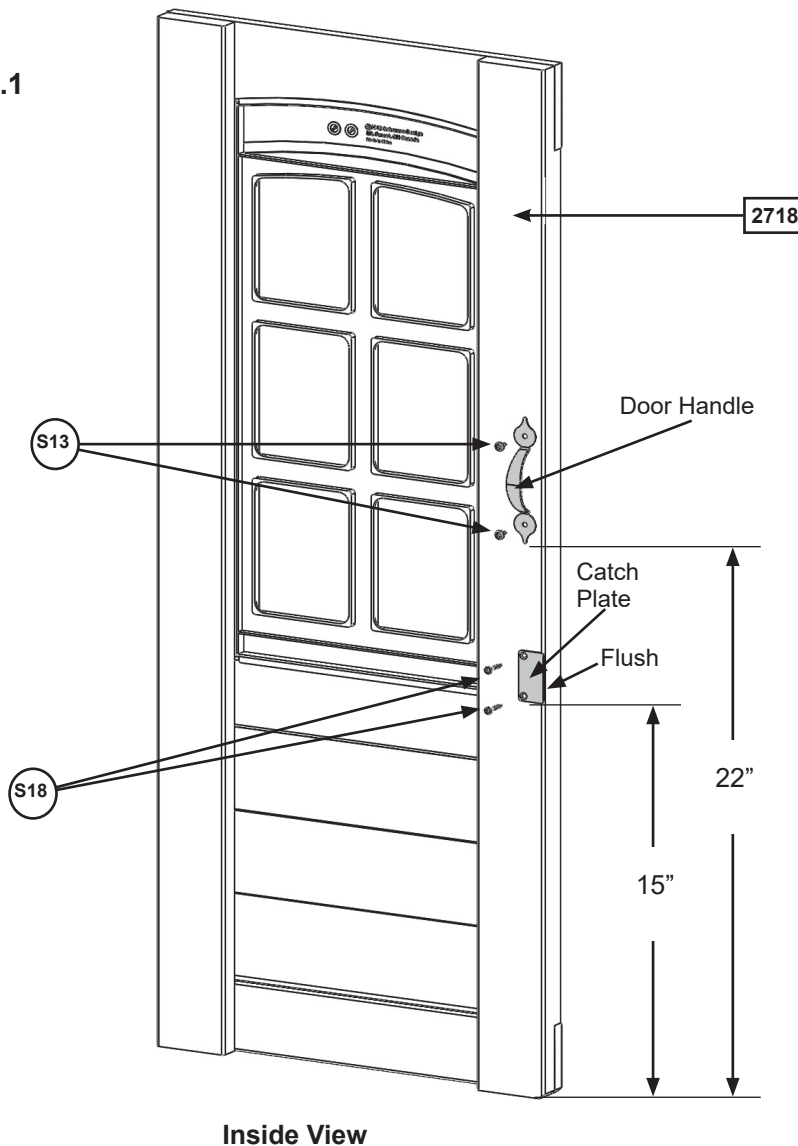
# Step 17: Attach Door Components Part 1



**A:** On the inside of (2718) Door Window Panel measure 15" up from the bottom and attach Catch Plate flush to the edge using 2 (S18) #6 x 1" Wood Screws. (fig. 17.1)

**B:** On the inside of (2718) Door Window Panel measure 22" up from the bottom and attach 1 Door Handle using 2 (S13) #6 x 5/8" Pan Screws. (fig. 17.1)

Fig. 17.1



## Wood Parts

1 x 2718 Door Window Panel 1-1/4 x 15-3/4 x 40-3/4"

## Hardware

2 x S18 #6 x 1" Wood Screw

2 x S13 #6 x 5/8" Pan Screw

## Other Parts

1 x Door Handle

1 x Catch Plate

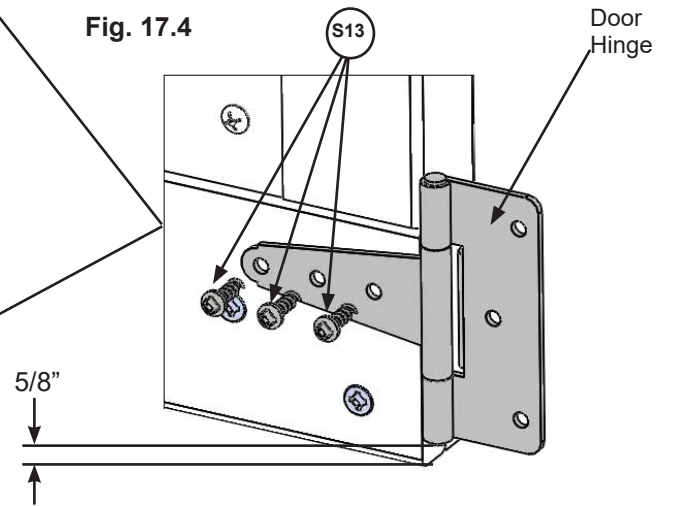
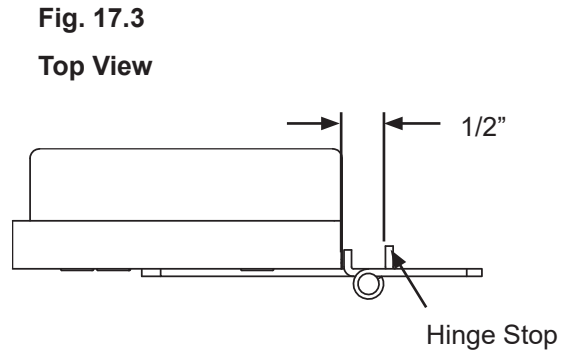
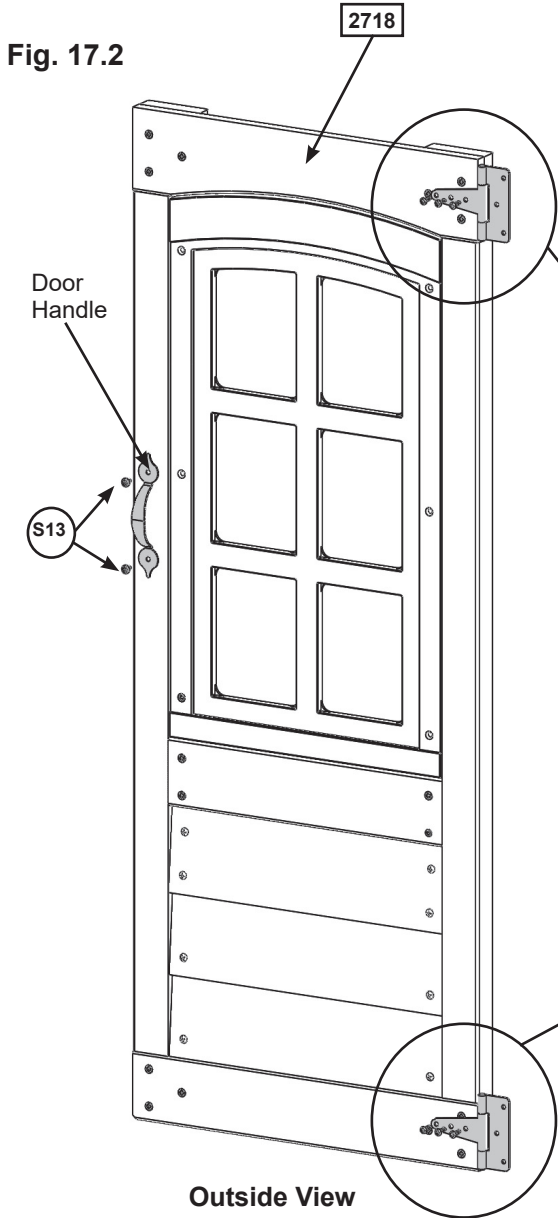
# Step 17: Attach Door Components Part 2



**C:** On the outside of the (2718) Door Window Panel attach the second Door Handle at approximately the same place as the one on the inside. Use 2 (S13) #6 x 5/8" Pan Screws. (fig. 17.2)

**D:** On the opposite side of the Door Handle measure 5/8" from the top and bottom of (2718) Door Window Panel attach 2 Door Hinges on the outside using 3 (S13) #6 x 5/8" Pan Screws per Hinge. (fig. 17.2 and 17.4)

**Note:** Hinge stops must be tight to (2718) Door Window Panel. (fig. 17.3)



**Hardware**  
8 x (S13) #6 x 5/8" Pan Screw

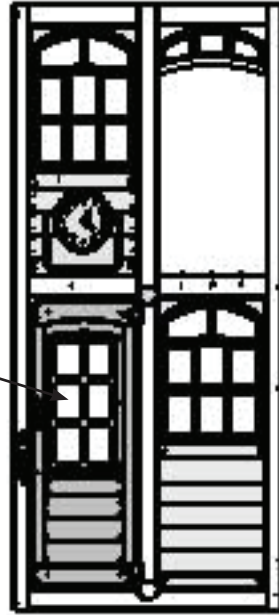
**Other Parts**  
1 x Door Handle  
2 x Door Hinge

# Step 18: Attach Door Assembly to Fort

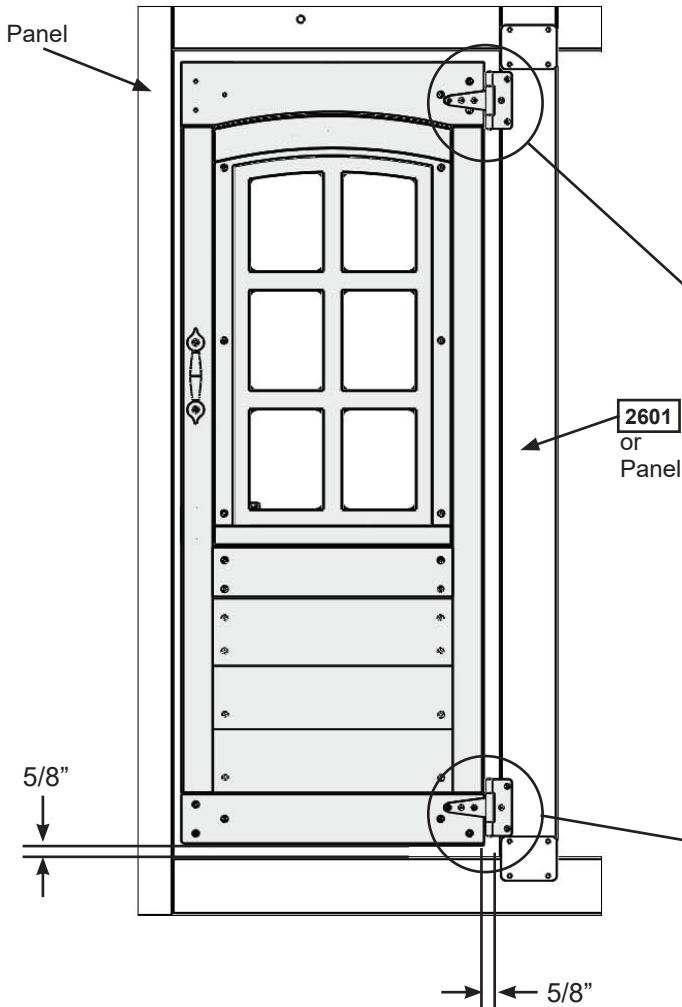


**A:** In the opening for the door as shown in Fig 18.1, measure 5/8" up from the bottom of the opening and maximum 5/8" from (2601) Lower Jamb or panel and attach the remaining side of the hinges to (2601) Lower Jamb or panel using 3 (S13) #6 x 5/8" Pan Screws per hinge. (fig. 18.1 and 18.2 and 18.3)

**Fig. 18.1**  
Front Wall



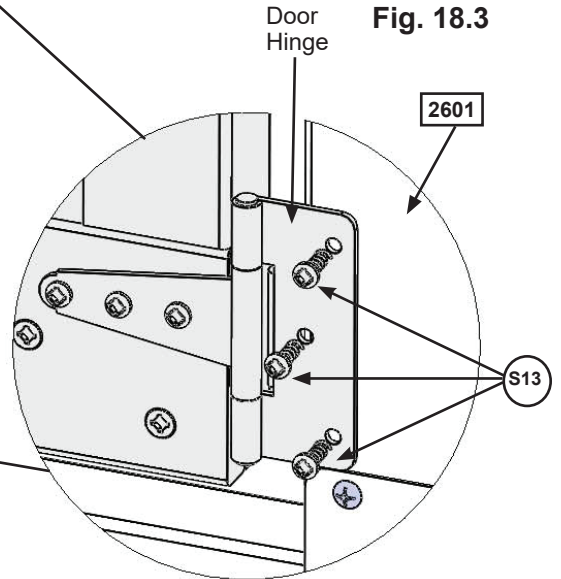
**Fig. 18.2**  
Outside View



2718

2601  
or  
Panel

**Fig. 18.3**



### Hardware

6 x (S13) #6 x 5/8" Pan Screw

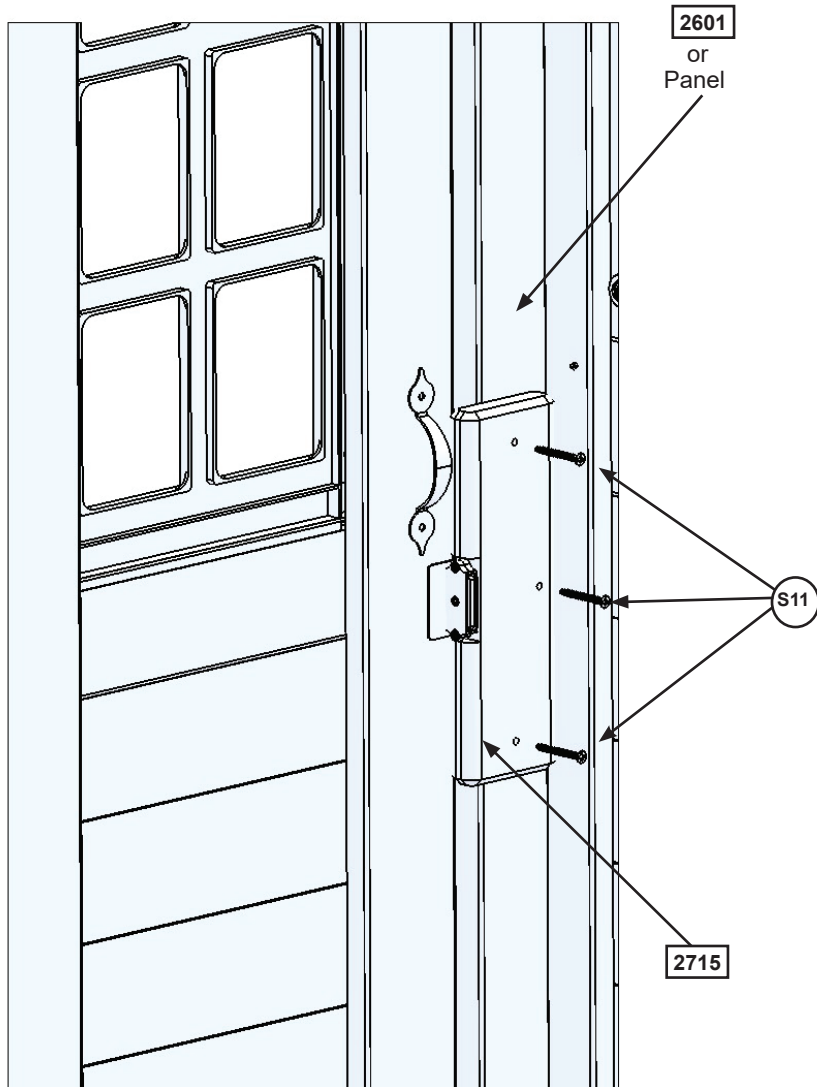
# Step 19: Attach Door Stop



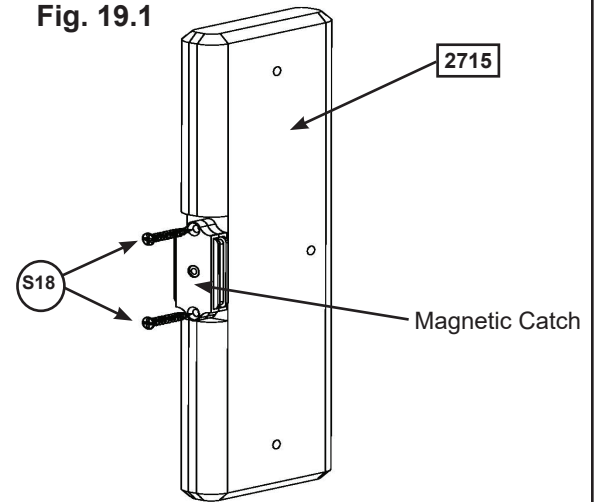
**A:** In the notched out opening of (2715) Door Stop attach the Magnetic Catch using 2 (S18) #6 x 1" Wood Screws. (fig. 19.1) **Important:** Use a hand held screw driver and **DO NOT** over tighten.

**B:** On the inside of the assembly, attach (2715) Door Stop to the panel with 3 (S11) #8 x 2" Wood Screws, making sure (2715) Door Stop overhangs the panel or (2601) Lower Jamb by 1-1/4" and is in position to receive the Catch Plate. (fig. 19.2 and 19.3).

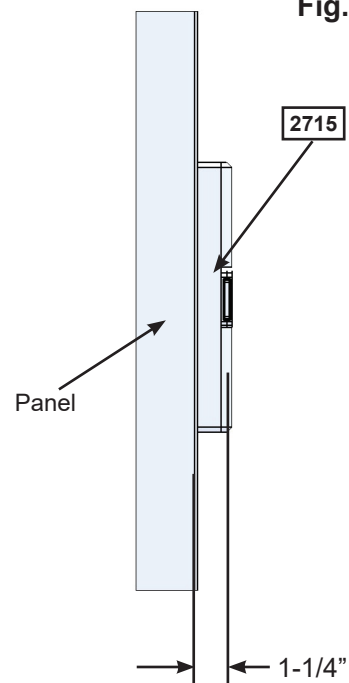
**Fig. 19.2**  
Inside View



**Fig. 19.1**



**Fig. 19.3**



**Wood Parts**

1 x 2715 Door Stop 5/4 x 3 x 10"

**Hardware**

2 x S18 #6 x 1" Wood Screw  
3 x S11 #8 x 2" Wood Screw

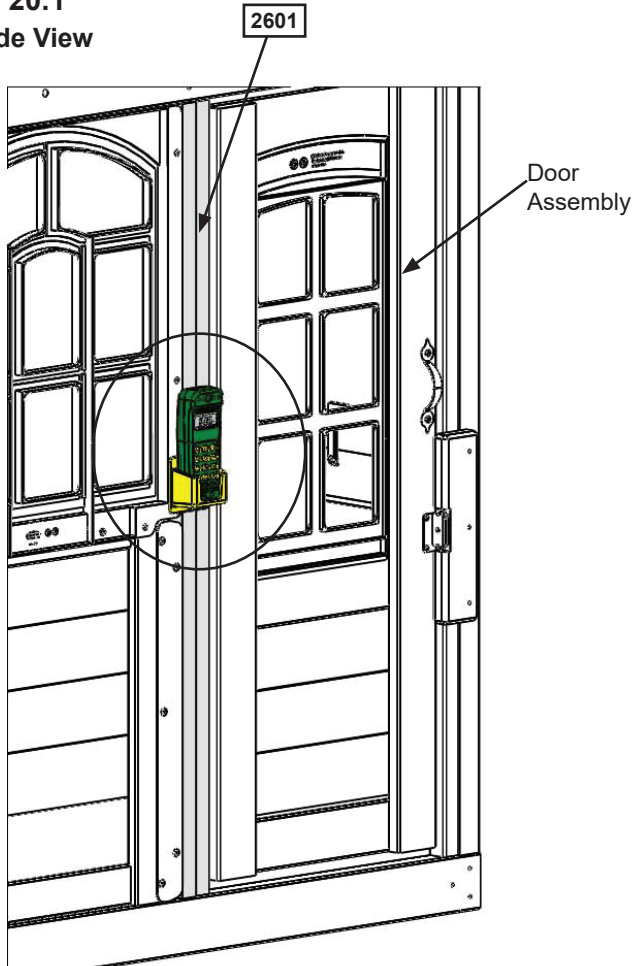
**Other Parts**

1 x Magnetic Catch

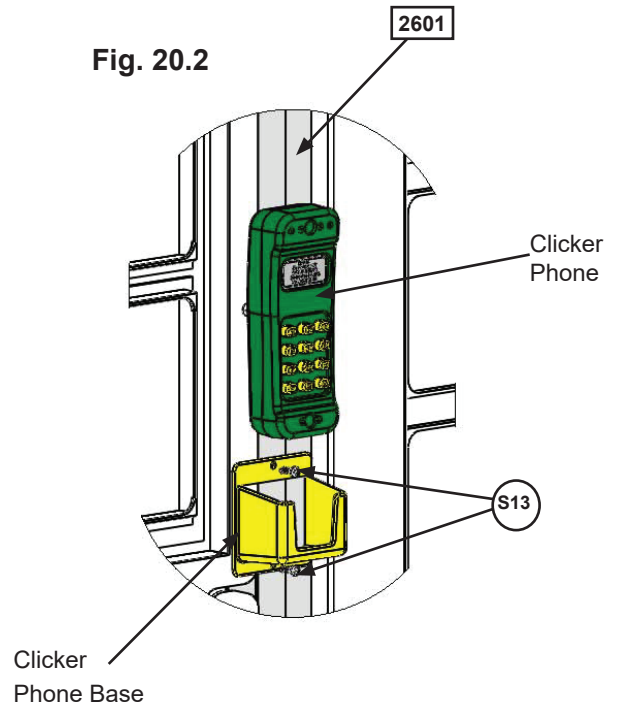
## Step 20: Attach Clicker Phone

**A:** On the (2601) Lower Jamb beside the Door Assembly install the Phone Base with 2 (S13) #6 x 5/8" Pan Screws then place the Clicker Phone in the Phone Base. (fig. 20.1 and 20.2)


**Fig. 20.1**  
Inside View



**Fig. 20.2**



### Hardware

2 x  #6 x 5/8" Pan Screw

### Other Parts

1 x Clicker Phone Set

# Step 21: Attach Slide to Fort



**A:** Place Slide in the centre of the opening as shown in 21.1, pre-drill with a 1/8" drill bit then attach slide to fort through the panel using 3 (S7) #12 x 2" Pan Screws. (fig. 21.1 and 21.2, 21.3)

Fig. 21.1

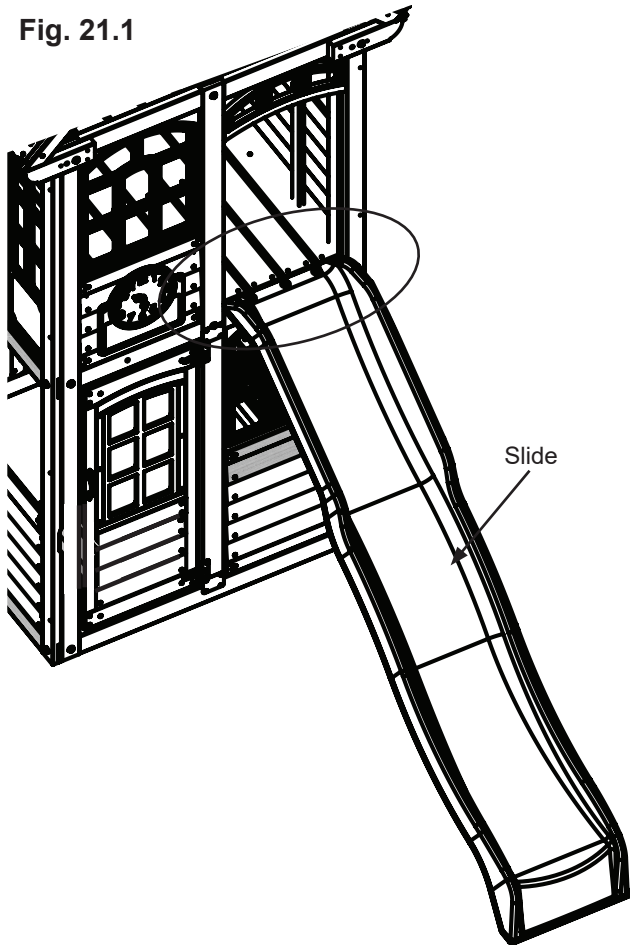


Fig. 21.2

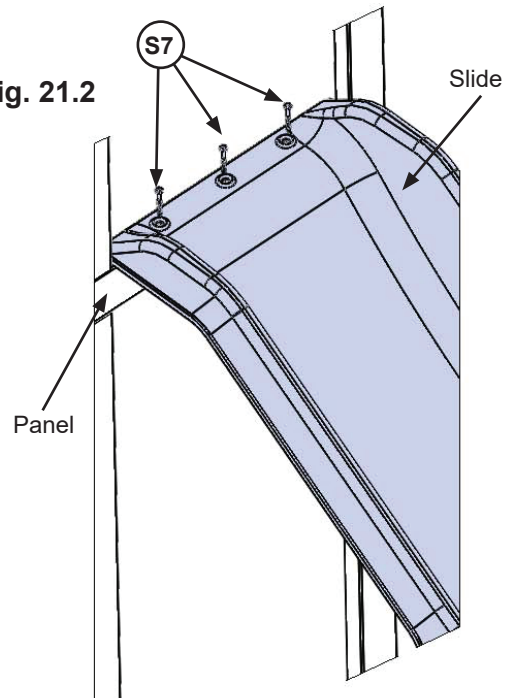
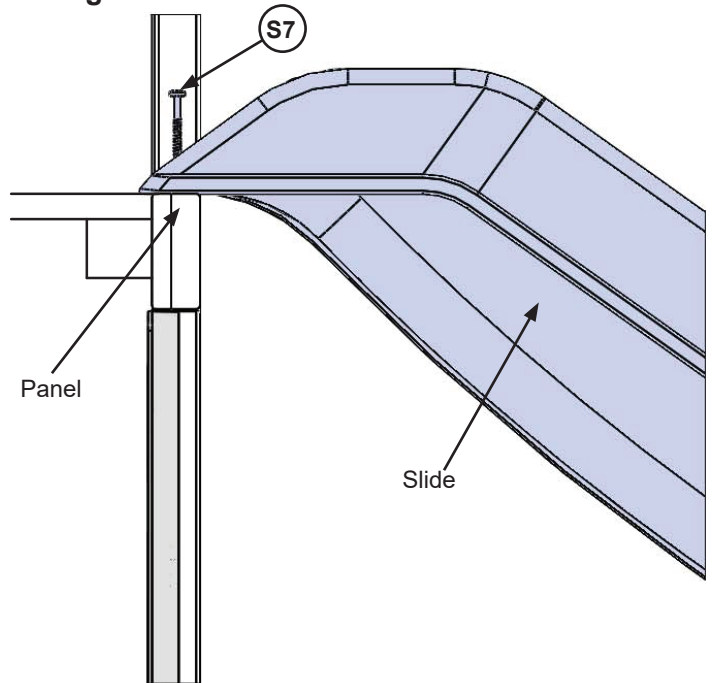



Fig. 21.3



### Hardware

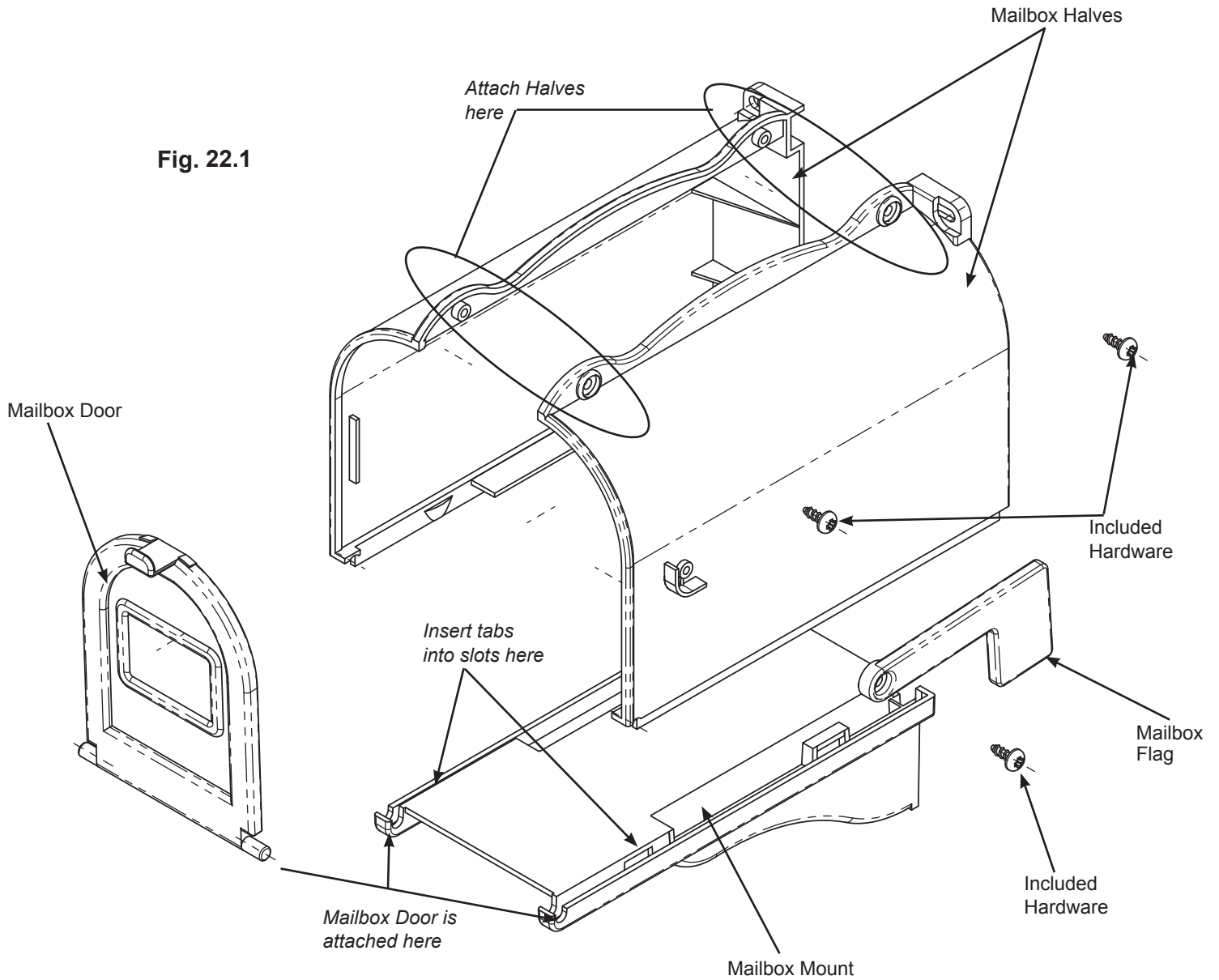
3 x  #12 x 2" Pan Screw

### Other Parts

1 x Slide

# Step 22: Attach Mail Box Part 1

- A: Place both Mailbox Halves together and attach at the top with included hardware. (fig. 22.1)
- B: Snap Mailbox Door onto Mailbox Mount. (fig. 22.1)
- C: Place assembled Mailbox on Mailbox Mount and slide into place using the tabs and slots. (fig. 22.1)
- D: Attach Mailbox Flag to Mailbox with included hardware. (fig. 22.1)



### Other Parts

1 x Mailbox  
(with included hardware)

## Step 22: Attach Mail Box Part 2

**E:** Place Mailbox Assembly on the panel then attach with 1 (S10) #8 x 1" Pan Screw from the bottom and 2 (S10) #8 x 1" Pan Screws on the top. (fig. 22.2, 22.3 and 22.4)

**F:** For the remaining 2 holes, attach with 2 (S13) #6 x 5/8" Pan screws. (fig.22.3)

Fig. 22.2

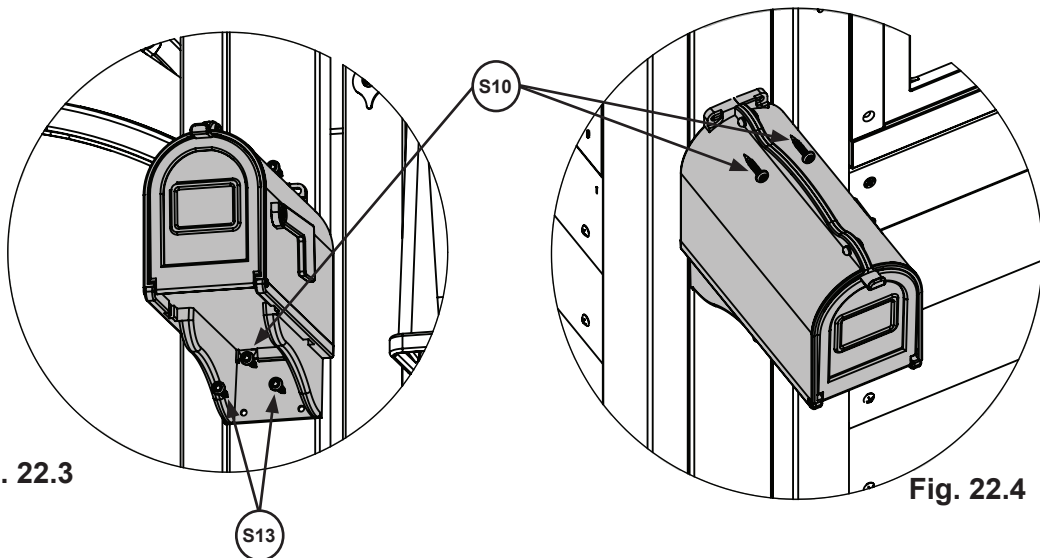
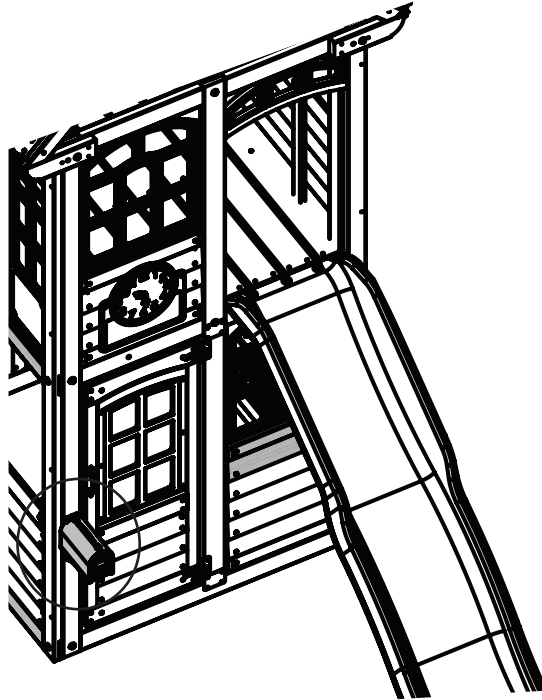


Fig. 22.3

Fig. 22.4

### Hardware

3 x (S10) #8 x 1" Pan Screw

2 x (S13) #6 x 5/8" Pan Screw

## Step 23: Roof Support Assembly

**A:** Attach 1 (2617) Roof Support to a second (2617) Roof Support at peak using 1 (S4) #8 x 3" Wood Screw. Repeat this step so there are 2 Roof Support Assemblies. (fig. 23.1 and 23.2)

Fig. 23.1

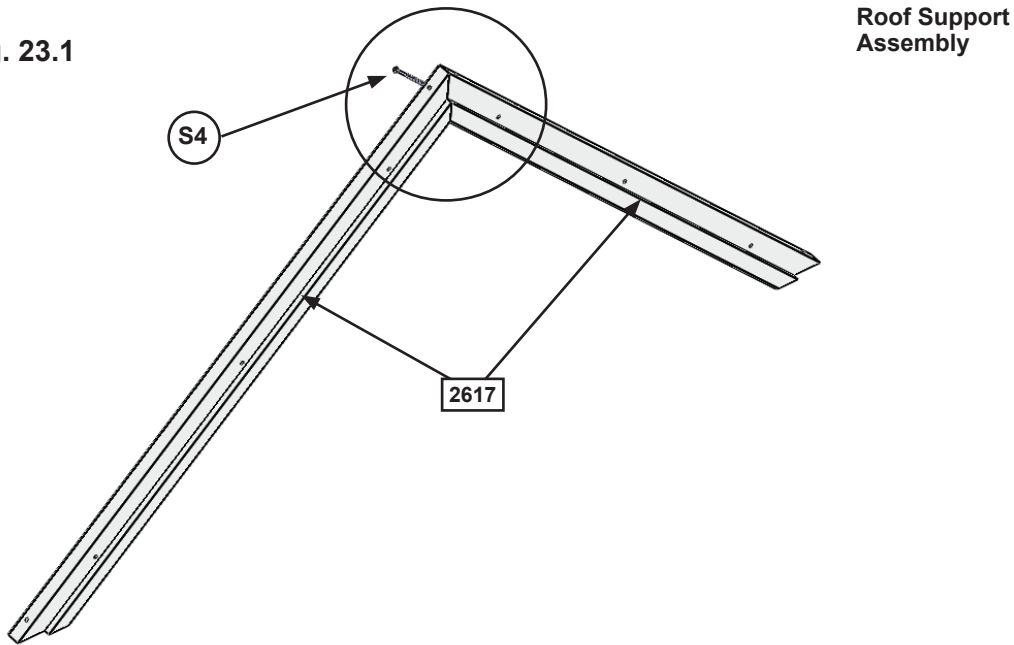
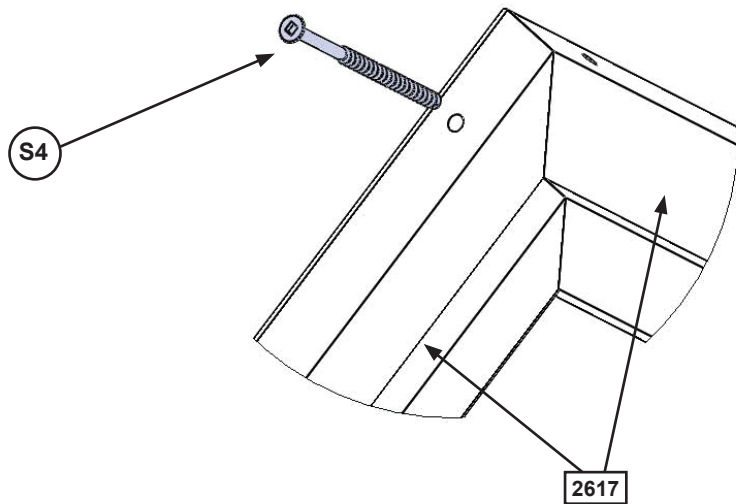



Fig. 23.2



### Wood Parts

4 x  Roof Support 1-1/4 x 2-1/4 x 37-1/2"

### Hardware

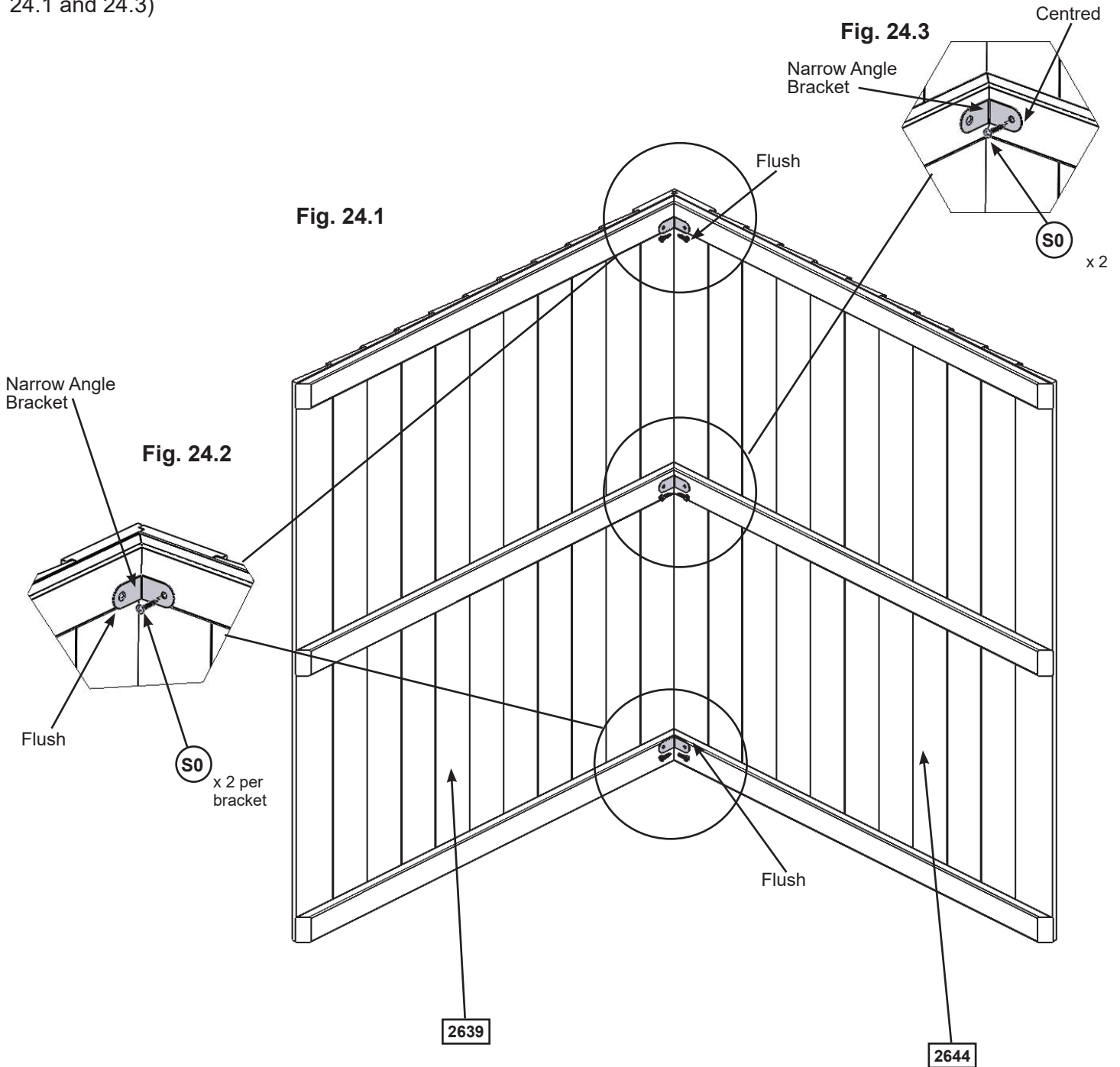
2 x  #8 x 3" Wood Screw

# Step 24: Roof Assembly Part 1



**A:** Place (2644) Front Roof Panel against (2639) Back Roof Panel so the tops form a peak then tight to the inside edge of the outside slats attach 1 Narrow Angle Bracket per slat with 2 (S0) #8 x 7/8" Truss Screws per bracket. (fig. 24.1 and 24.2)

**B:** Attach the third Narrow Angle Bracket centred on the middle slat with 2 (S0) #8 x 7/8" Truss Screws. (fig. 24.1 and 24.3)



### Wood Parts

- 1 x 2644 Front Roof Panel 1-1/4 x 37 x 44"
- 1 x 2639 Back Roof Panel 1-1/4 x 36-3/4 x 44"

### Hardware

- 6 x S0 #8 x 7/8" Truss Screw

### Other Parts

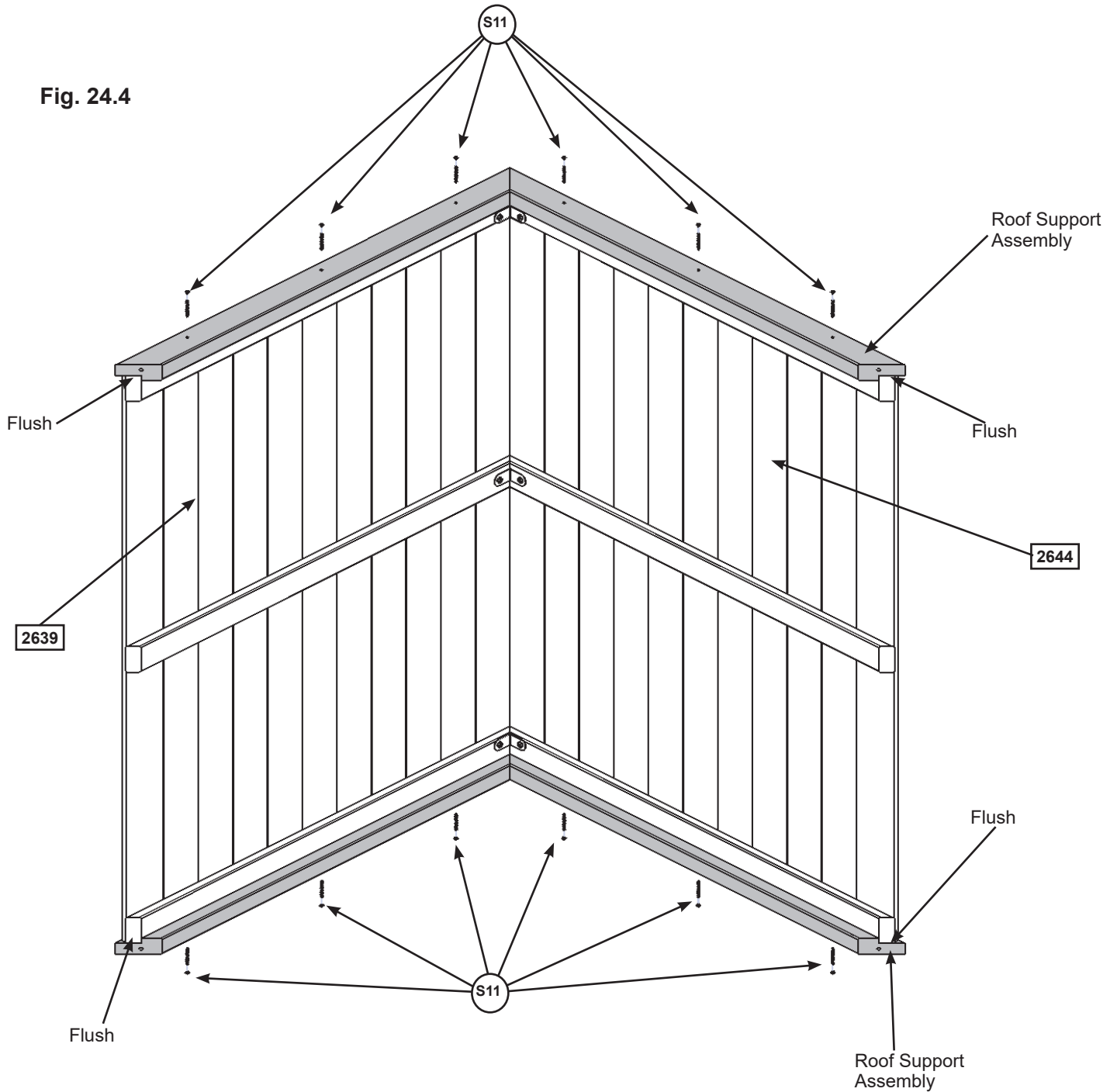
- 3 x Narrow Angle Bracket

# Step 24: Roof Assembly Part 2


**C:** Place 1 Roof Support Assembly against one side so the peaks meet and the ends of the roof supports are flush with the ends of the roof panels. Attach with 6 (S11) #8 x 2" Wood Screws. (fig. 24.4)

**D:** Attach the second Roof Support Assembly on the opposite side, peaks to meet and ends are flush with 6 (S11) #8 x 2" Wood Screws. (fig. 24.4)

Fig. 24.4



### Hardware

12 x  #8 x 2" Wood Screw

## Step 25: Attach Peak Detail

**A:** Attach 1 Peak Detail to the inside of the (2617) Roof Supports on each side of the Roof Assembly with 8 (S8) #12 x 3/4" Pan Screws (with 1/4" flat washer) per Peak Detail. (fig. 25.1 and 25.2)

Fig. 25.1

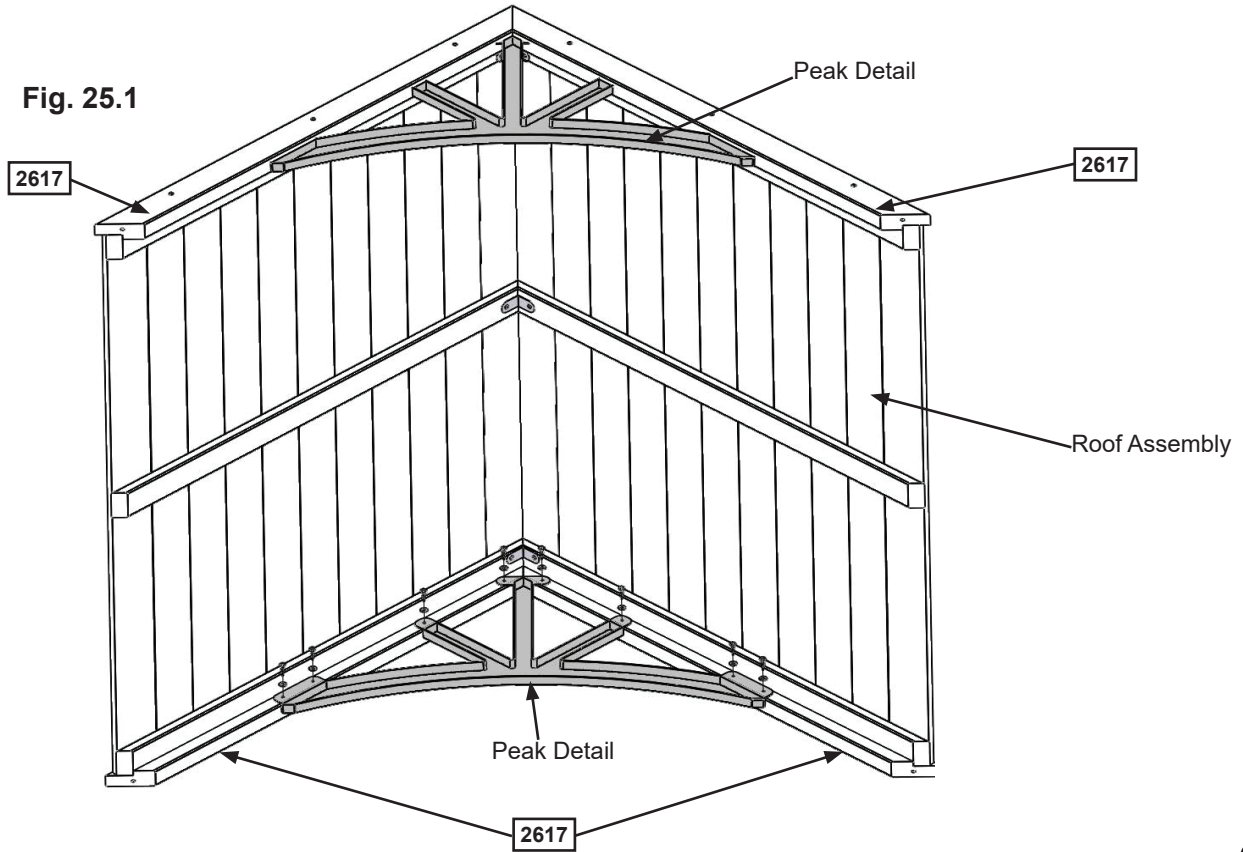
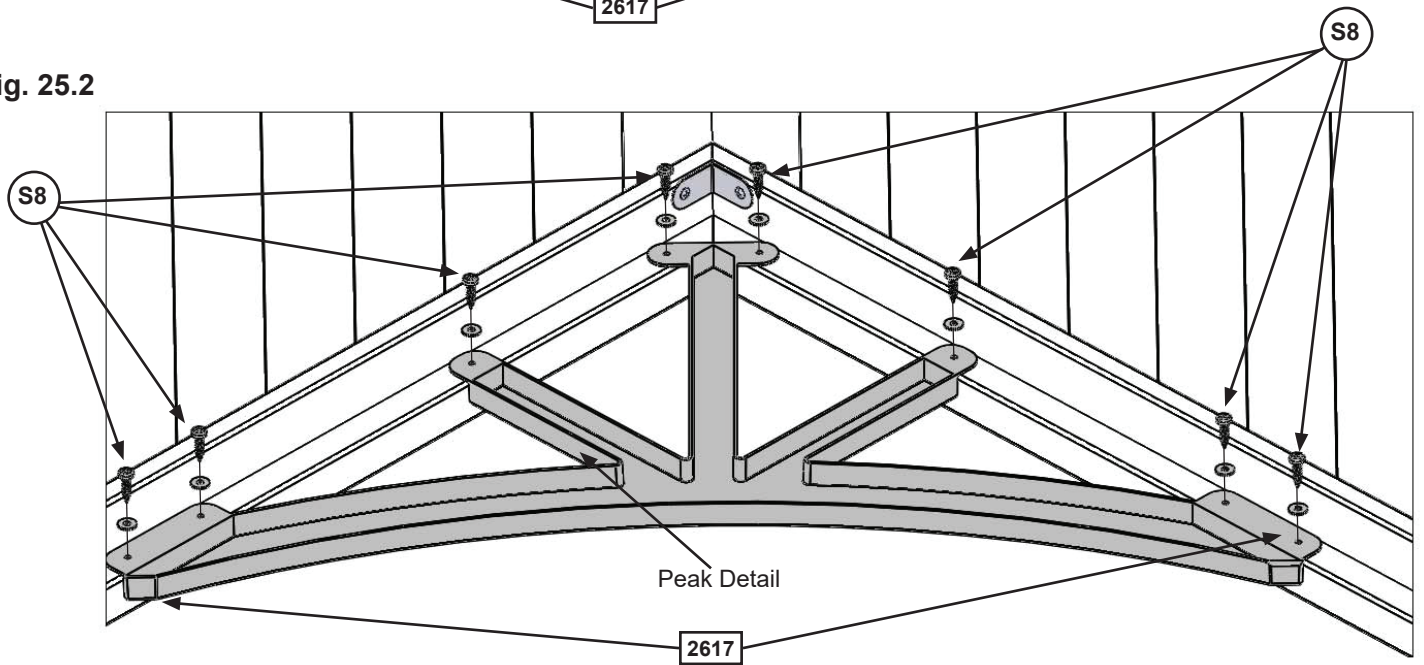


Fig. 25.2



### Hardware

16 x (S8) #12 x 3/4" Pan Screw  
(1/4" flat washer)

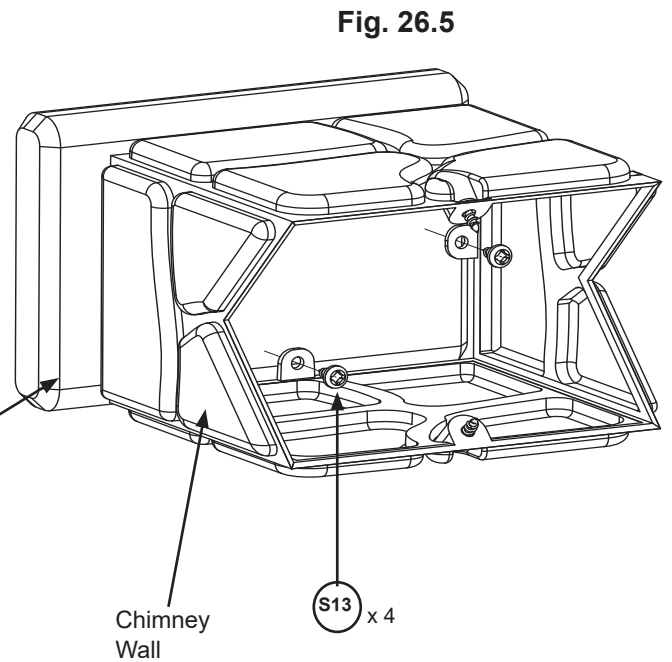
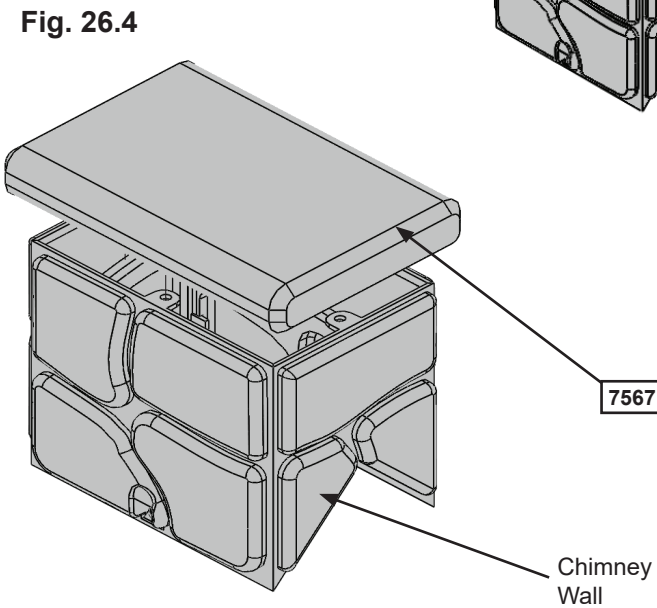
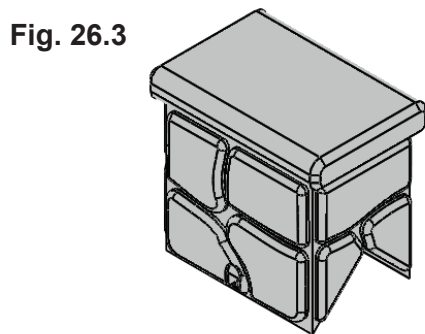
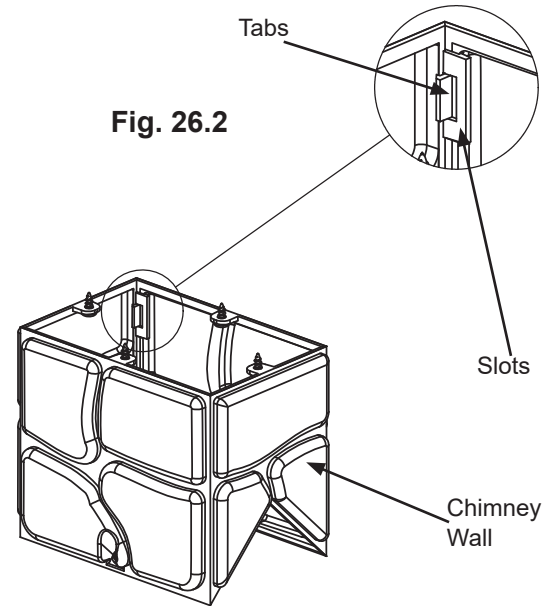
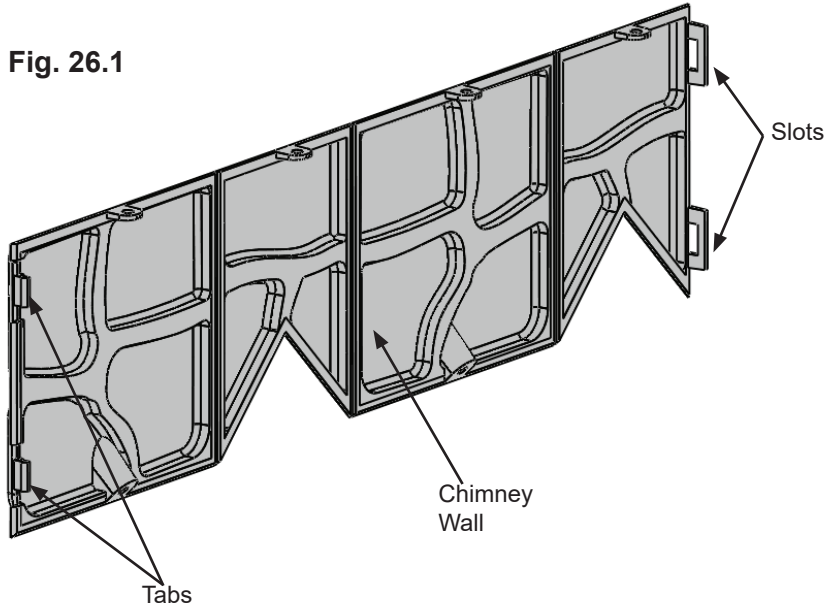
### Other Parts

2 x Peak Detail

# Step 26: Chimney Wall Assembly Part 1

**A:** Bend the Chimney Wall to form a box and insert tabs into slots. (fig. 26.1 and 26.2)

**B:** Place the (7567) Chimney Top on top of the assembly and attach with 4 (S13) #6 x 5/8" Pan Screws. (fig. 26.3, 26.4 and 26.5)



### Wood Parts

1 x 7567 Chimney Top 15/16 x 4-1/4 x 6-1/4"

### Hardware

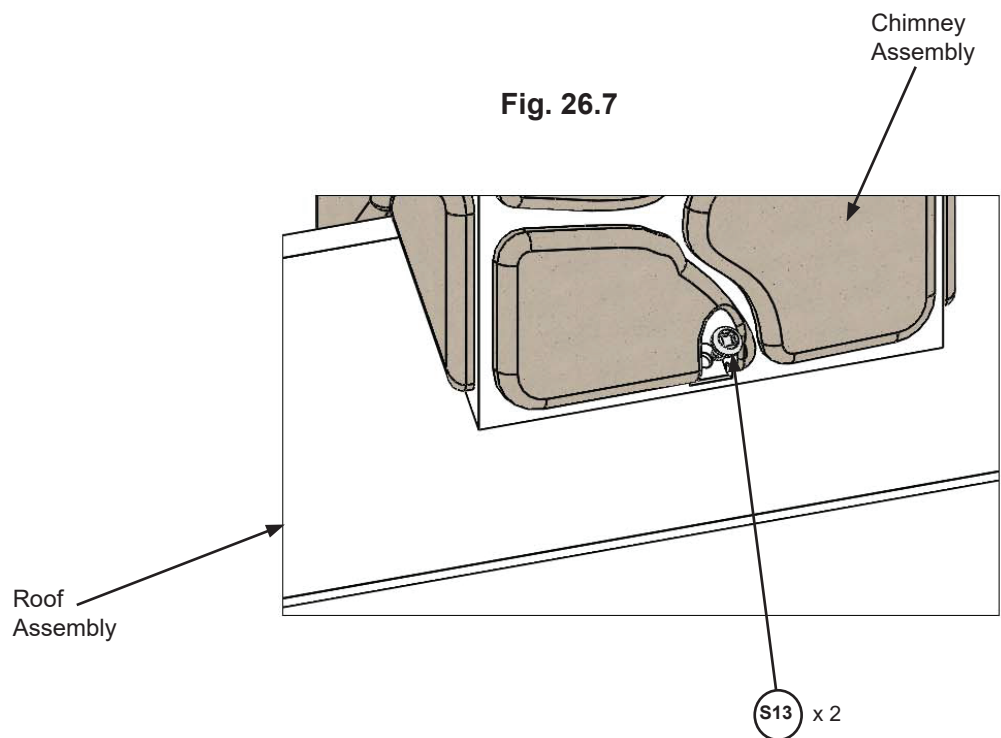
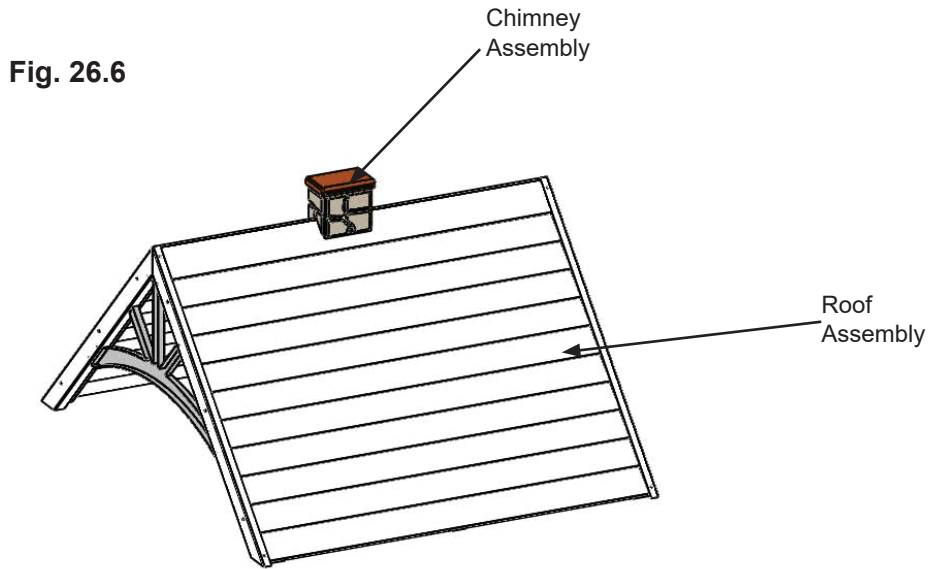
4 x S13 #6 x 5/8" Pan Screw

### Other Parts

1 x Chimney Wall Set

## Step 26: Chimney Wall Assembly Part 2

C: Place the Chimney Wall Assembly centred on top of the Roof Assembly and attach with 2 (S13) #6 x 5/8" Pan Screws. (fig. 26.6 and 26.7)



### Hardware

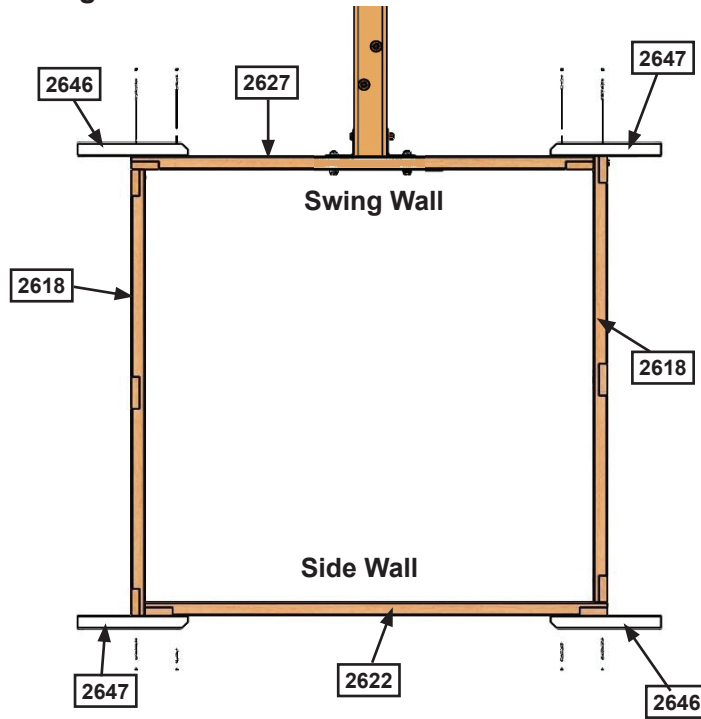
2 x (S13) #6 x 5/8" Pan Screw

# Step 27: Attach Roof Ends

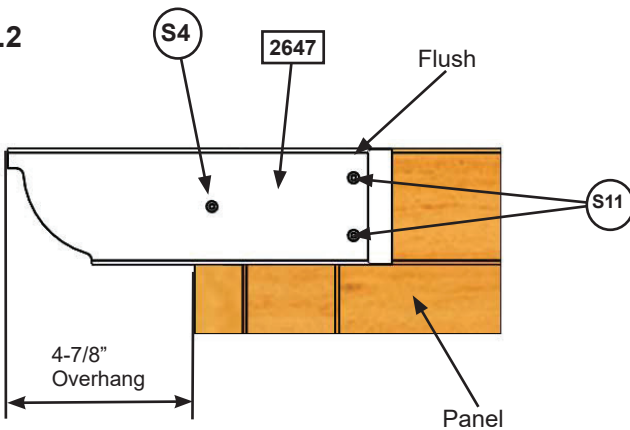


**A:** Place 2 (2646) Roof Ends flush to the top and right hand side of the panels and 2 (2647) Roof End Lefts flush to the top and left hand side of the panels, measure overhang so it is 4-7/8" then attach with 2 (S11) #8 x 2" Wood Screws and 1 (S4) #8 x 3" Wood Screw. (fig. 27.1, 27.2 and 27.3)

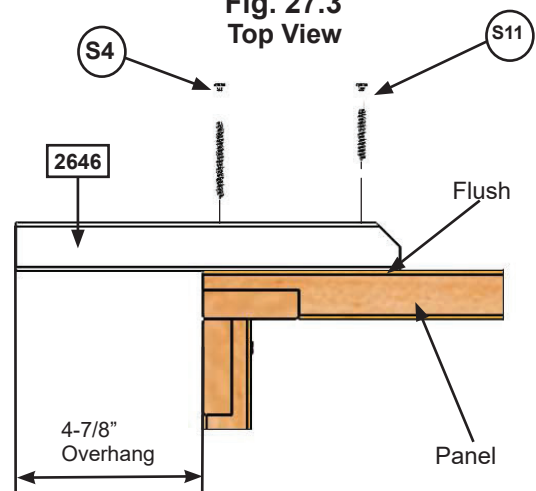
**Fig. 27.1**



**Fig. 27.2**



**Fig. 27.3  
Top View**



**Wood Parts**

- 2 x 2646 Roof End 1-1/4 x 3 x 10"
- 2 x 2647 Roof End Left 1-1/4 x 3 x 10"

**Hardware**

- 4 x S4 #8 x 3" Wood Screw
- 8 x S11 #8 x 2" Wood Screw

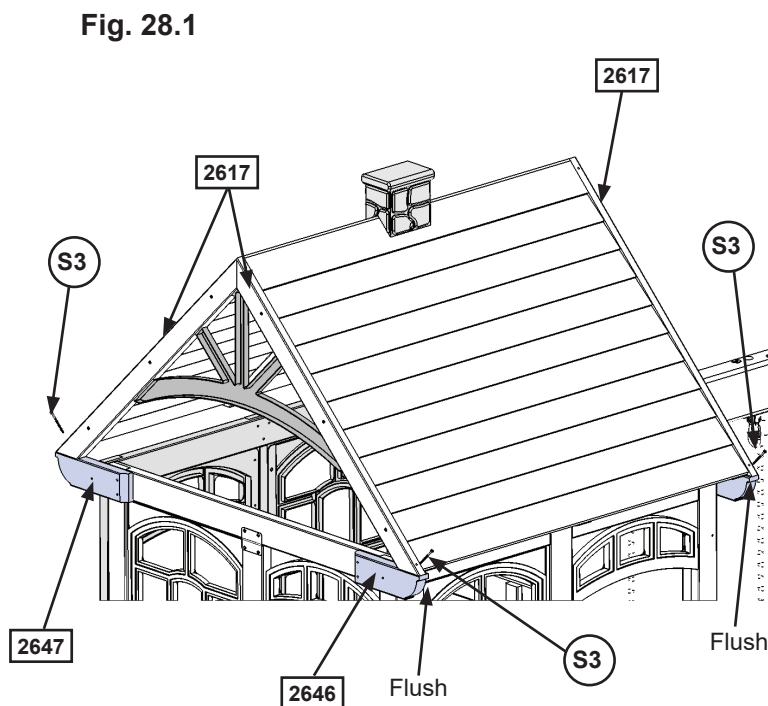
## Step 28: Attach Roof Assembly to Fort



**A:** With 2 people on the ground and at least 1 person in the fort, lift the Roof Assembly up and over the Back side of the fort. Guide the Roof Assembly onto the fort so all four (2617) Roof Supports sit flush to the front and outside edges of (2646) Roof End and (2647) Roof End Left. (fig. 28.1, 28.2 and 28.3)

**B:** Attach (2617) Roof Supports to (2646) Roof End and (2647) Roof End Left with 1 (S3) #8 x 2-1/2" Wood Screw per support. (fig. 28.1)

**Fig. 28.1**



### **Hardware**

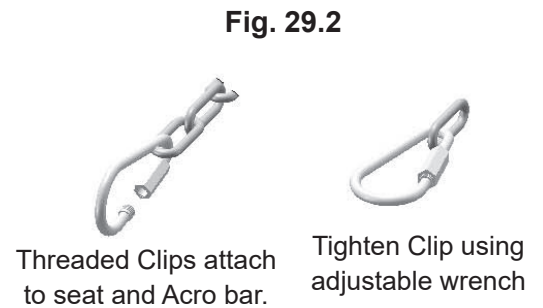
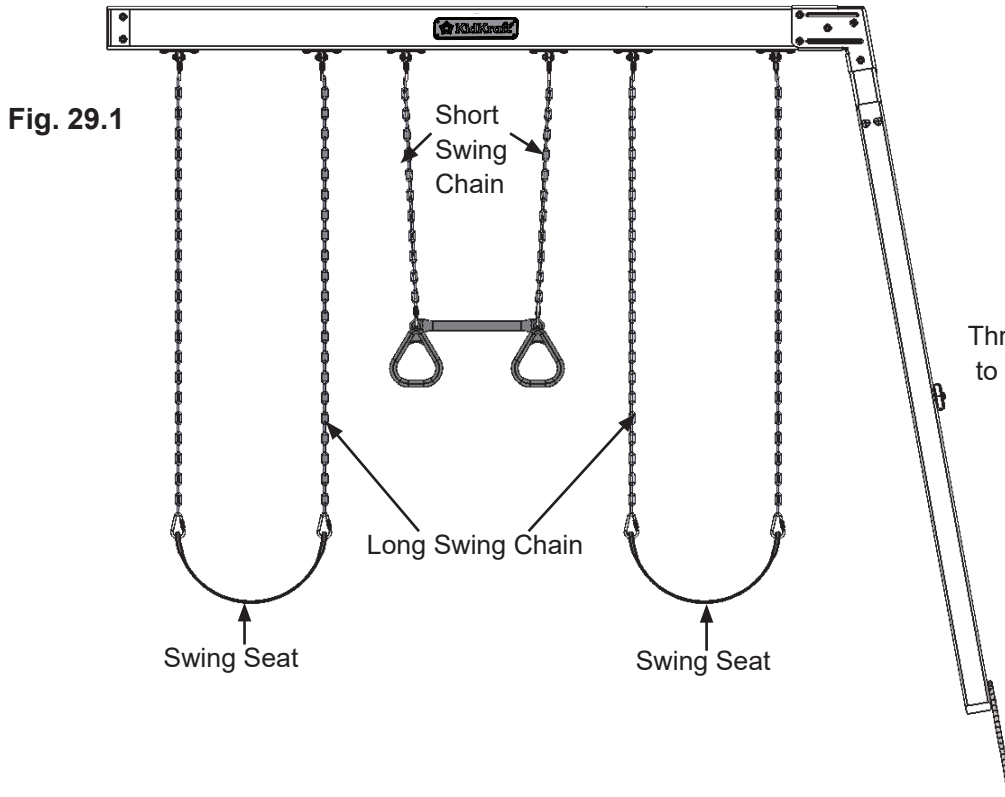
4 x **S3** #8 x 2-1/2" Wood Screw

## Step 29: Attach Acro and Belt Swings

**A:** Using 1 Threaded Clip per chain, join 1 Long Swing Chain to each side of the swing belt seat. Make sure to close the Threaded Clip tightly using an adjustable wrench. (fig. 29.1 and 29.2).

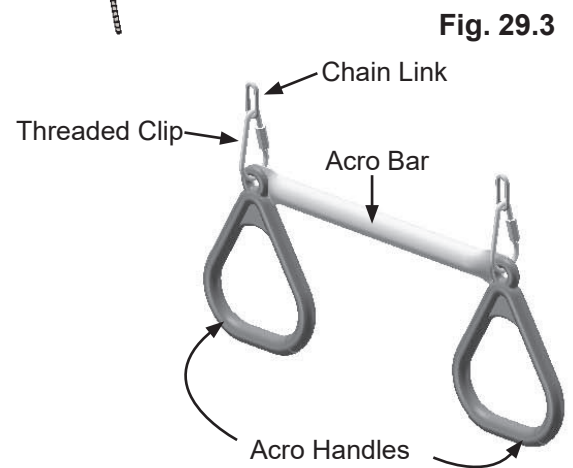
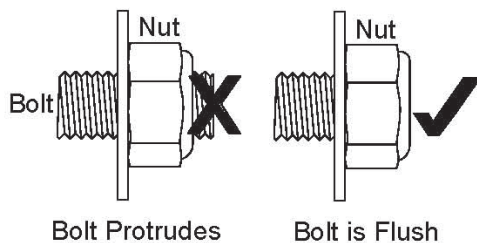
**B:** Using 1 Threaded Clip per chain, join the Short Swing Chain to the Acro Bar and Acro Handle. Make sure to close the Threaded Clip tightly using an adjustable wrench. (fig. 29.2 and 29.3)

**C:** Attach the other end of the swing chains to the Quick Clips attached to the swing hangers and make sure all Quick Links are tightened. (fig. 29.1)



**Warning!** Check entire play centre for bolts protruding beyond t-nuts. Use extra washers to eliminate this condition.

**Bolt must not exceed 1/2 thread past the nut**



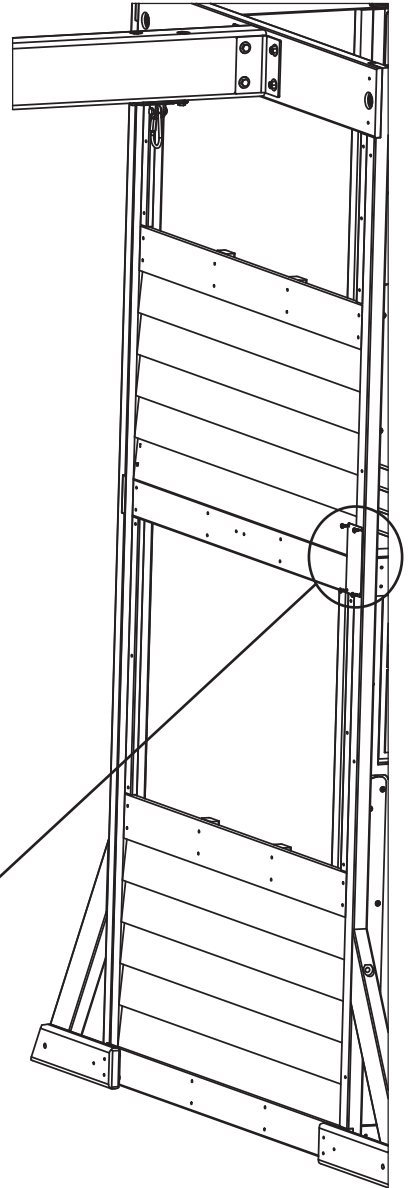
### Other Parts

- 1 x Acro Bar
- 2 x Acro Handle
- 2 x Swing Belt Seat
- 2 x Short Swing Chain
- 4 x Long Swing Chain
- 6 x Threaded Clips

# Final Step: Attach I.D. Plaque

## ATTACH THIS WARNING & I.D. PLAQUE TO THIS LOCATION ON YOUR PLAY EQUIPMENT!

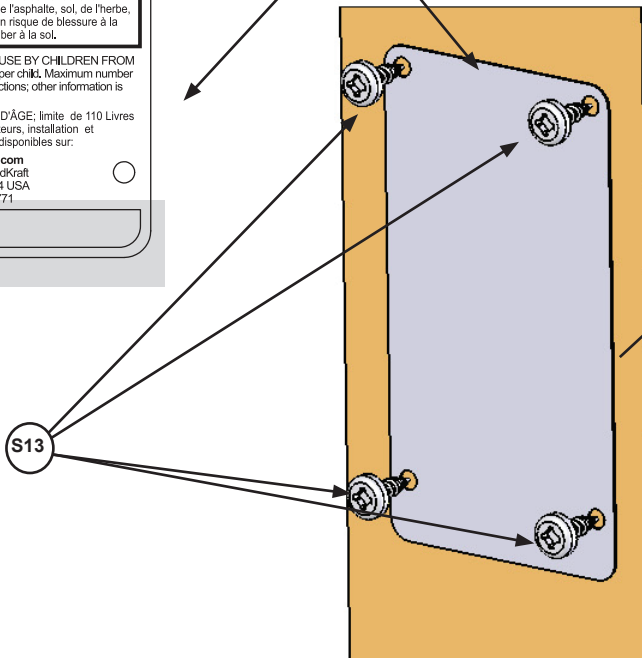
This provides warnings concerning safety and important contact information. A Tracking Number is provided to allow you to get critical information or order replacement parts for this specific model.



A: Attach KidKraft I.D. Plaque to a location on your set that is easily seen and read by a supervising adult using 4 (S13) #6 x 5/8" Pan Screws as shown below.



KidKraft I.D. Plaque



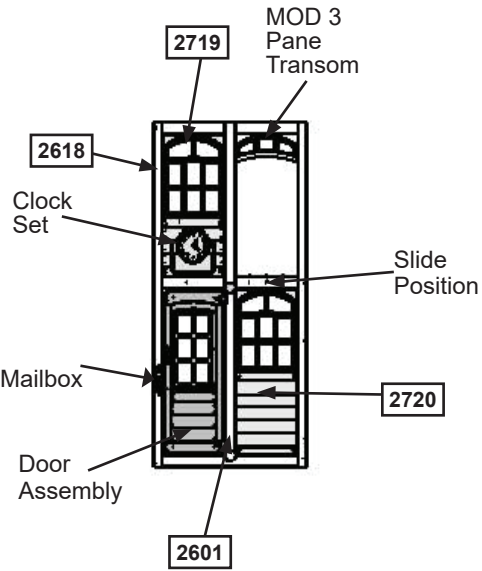
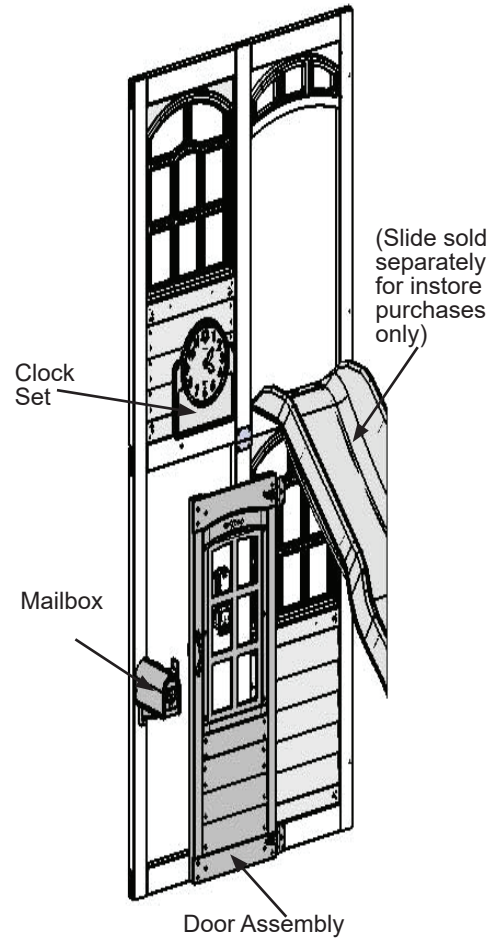
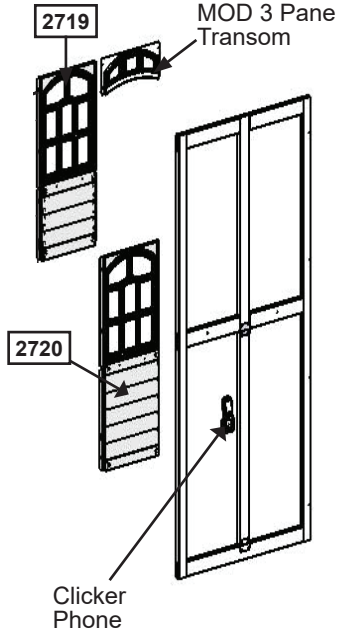
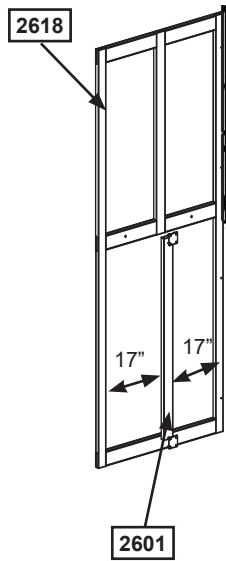
### Hardware

4 x (S13) #6 x 5/8" Pan Screw

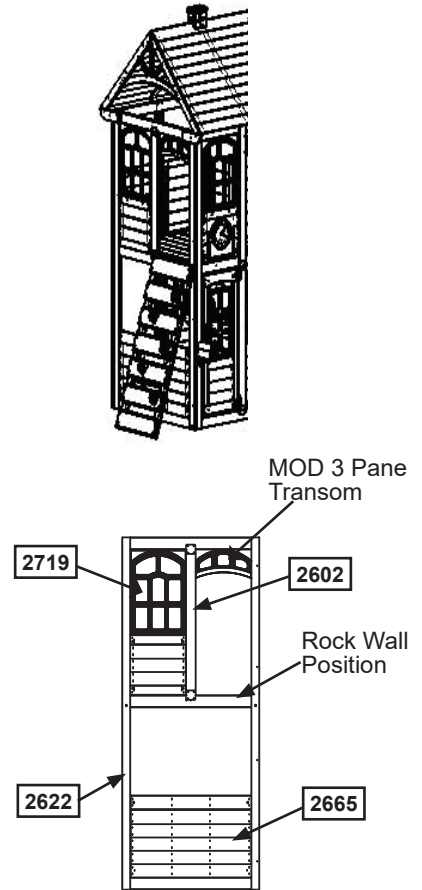
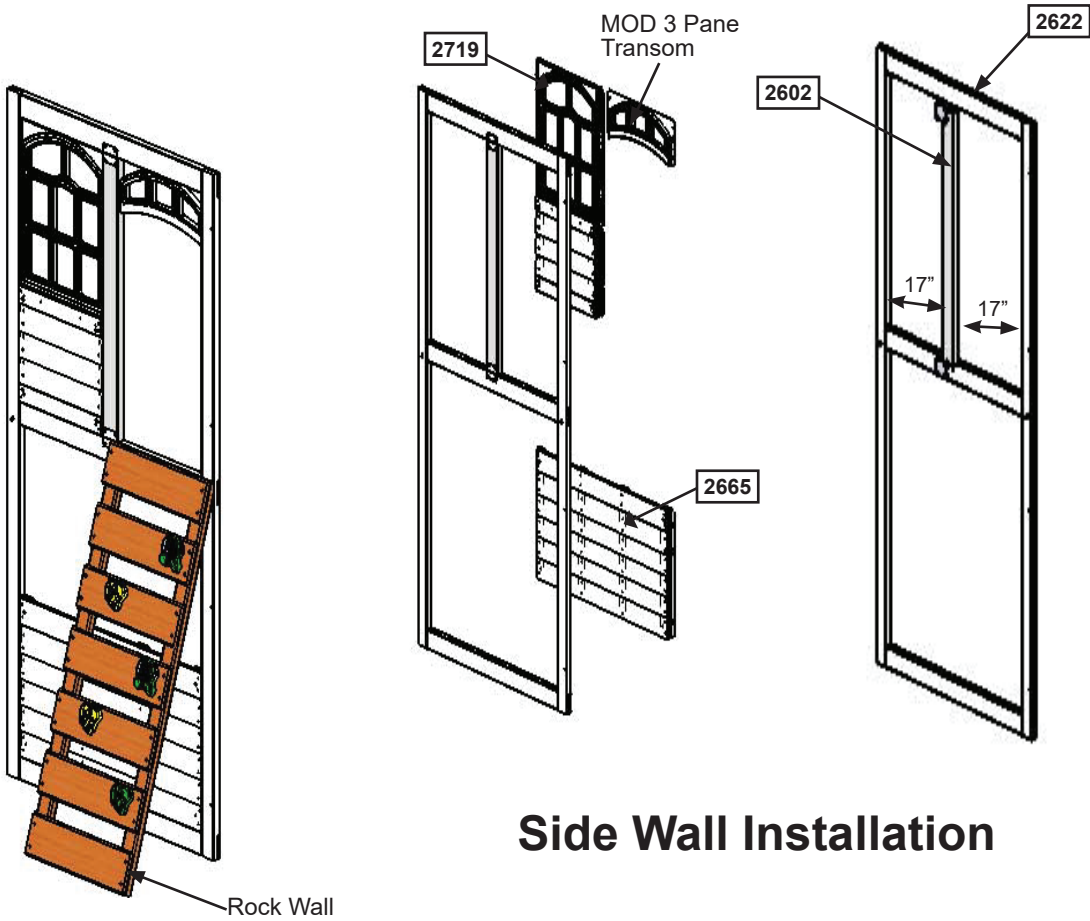
### Other Parts

1 x KidKraft I.D. Plaque

# Fort Guide: McKinley

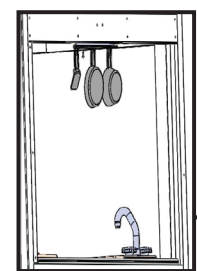


## Front Installation

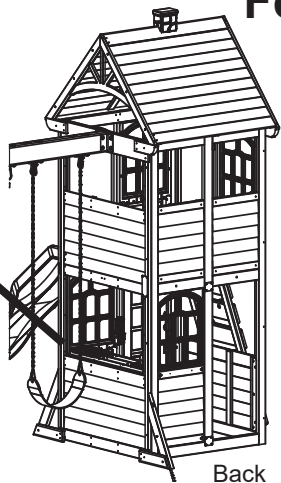


## Side Wall Installation

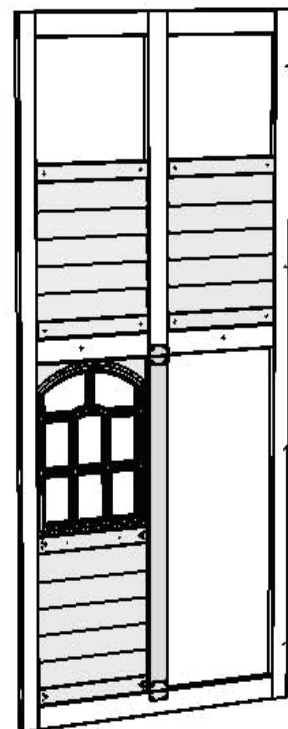
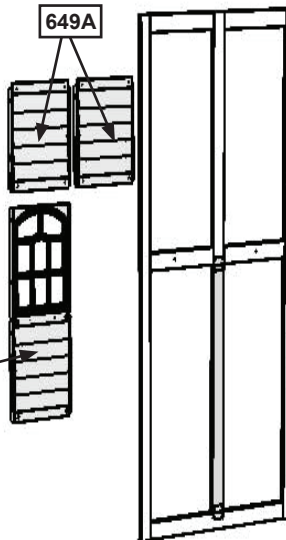
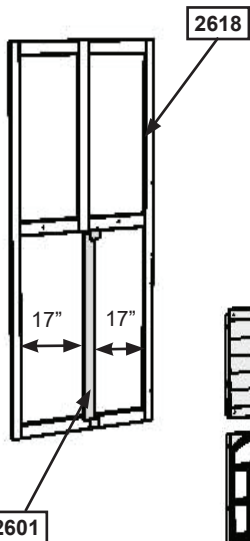
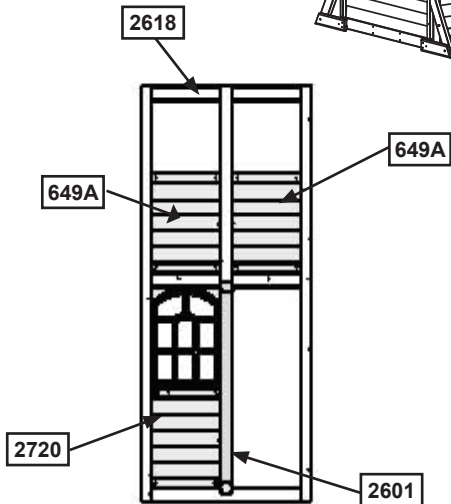
# Fort Guide: McKinley



Deluxe Kitchen Set

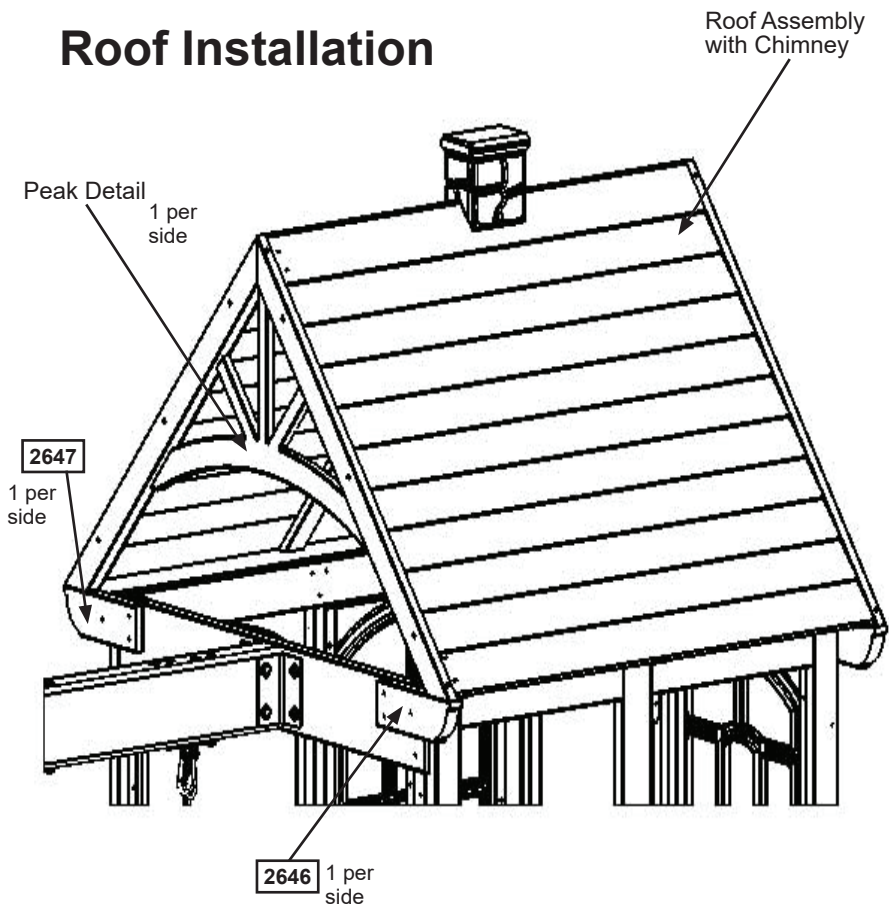


Back



## Back Installation

## Roof Installation



# 3 EASY WAYS TO REGISTER YOUR PRODUCT 24/7

- 1) Scan this QR Code with your smart phone to complete your product registration directly from your phone:
- 2) Complete the registration online at: [https://www.kidkraft.com/us\\_en/warranty/](https://www.kidkraft.com/us_en/warranty/)
- 3) Mail this completed form to: KidKraft Inc., 4630 Olin Road, Dallas, Tx 75244 USA  
Make sure to include a copy of your proof of purchase



## KIDKRAFT Consumer Registration Card

First Name  Initial  Last Name

Street  Apt. No.

City  State/Province  ZIP/Postal Code

Country  Telephone Number

E-Mail Address

Model Number  Model Name

Model Number & Name example  
F24145 AINSLEY PLAY SYSTEM

Purchased From  Date Purchase

MM / DD / YY

Serial Number (on ID Plaque)



ID Plaque example

Box #: _____ 1 of _____	Box #: _____ 4 of _____	<b>Box # (Ex: B29410 1 of 6)</b> <div style="border: 1px solid black; padding: 5px; display: inline-block;"> <b>1</b> OF <b>6</b>  <small>ITEM / ARTICLE N°</small>  <b>B29410</b> </div>
Box #: _____ 2 of _____	Box #: _____ 5 of _____	
Box #: _____ 3 of _____	Box #: _____ 6 of _____	

For common questions or for information on ordering replacement parts:

Help Center: <https://kidkraft.zendesk.com/hc/en-us/>

