

Product Installation Instructions

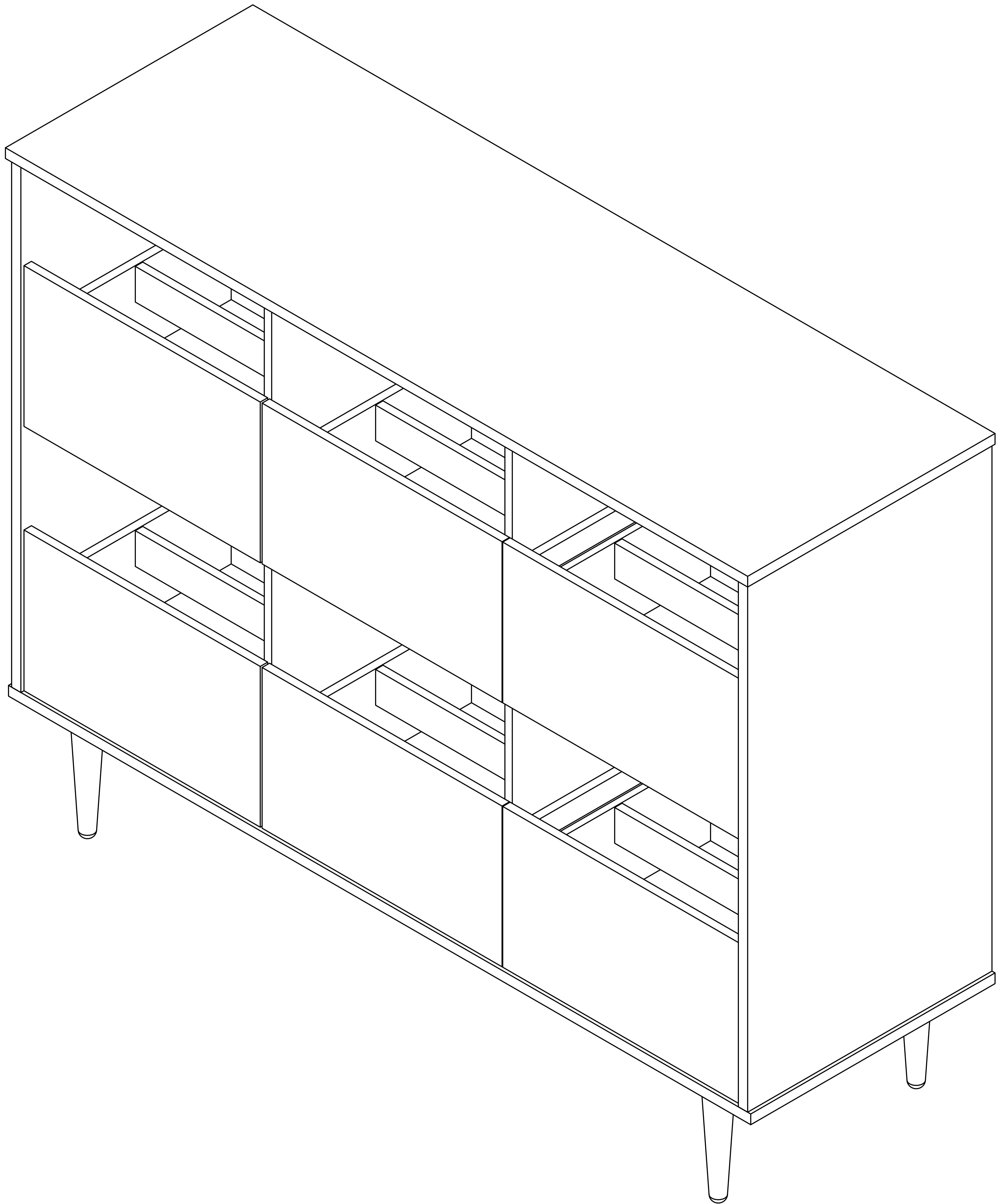

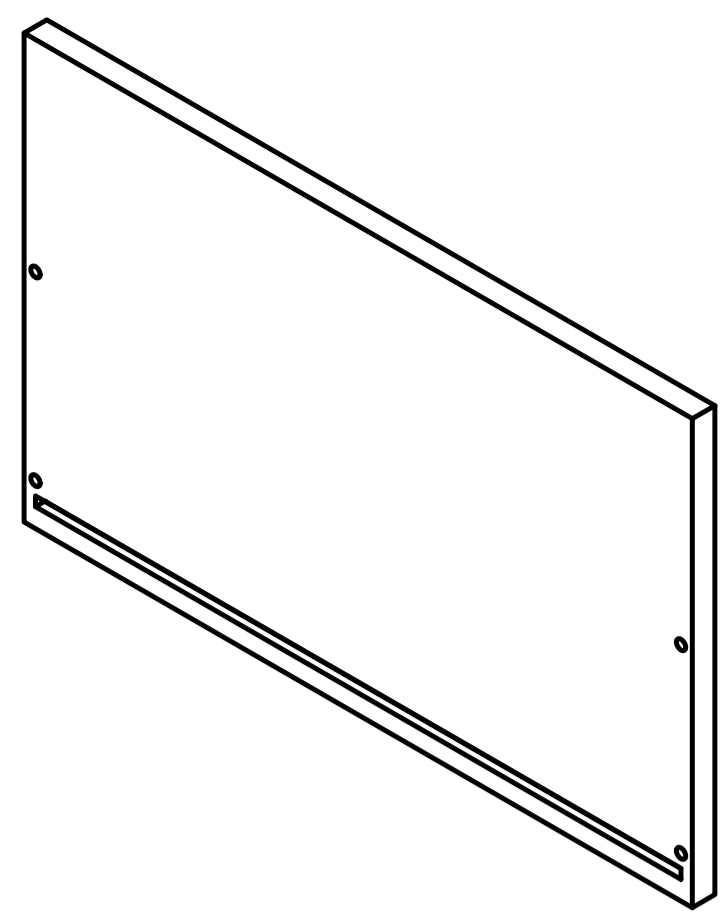

A x6

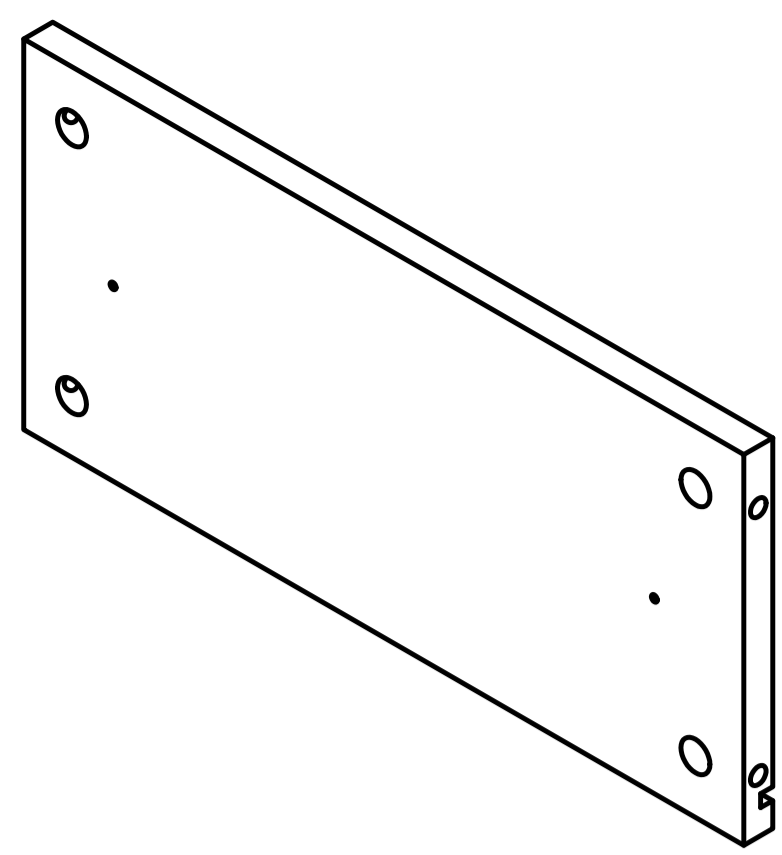

Bx12

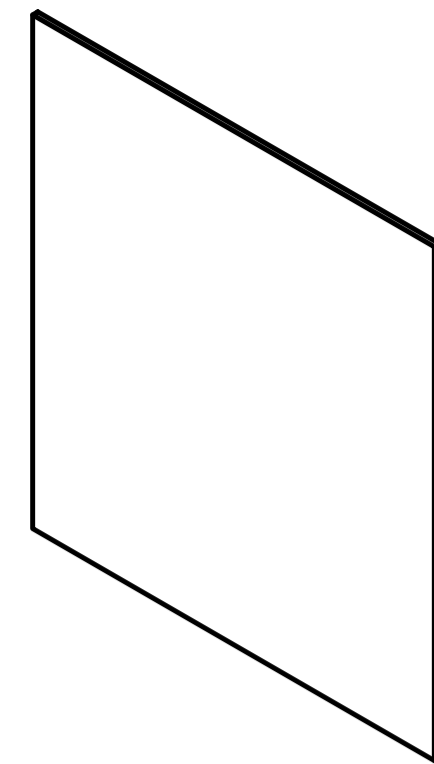

C x6

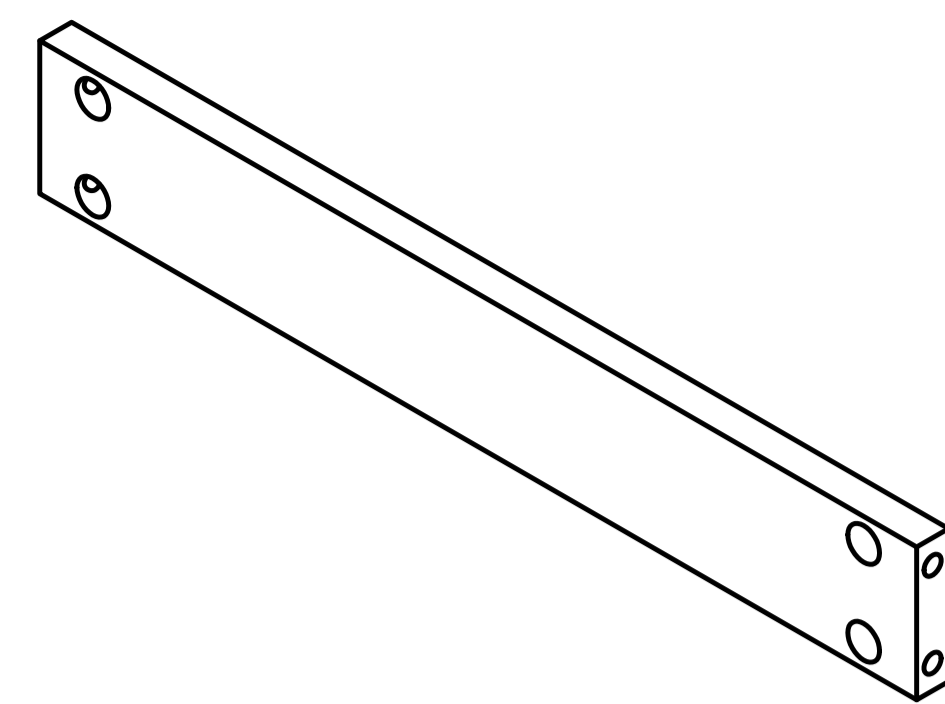

D x6

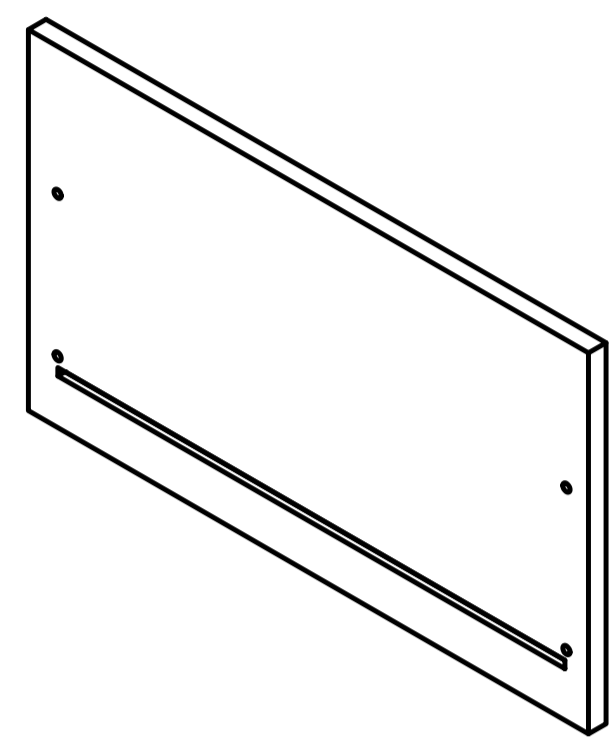

E x2

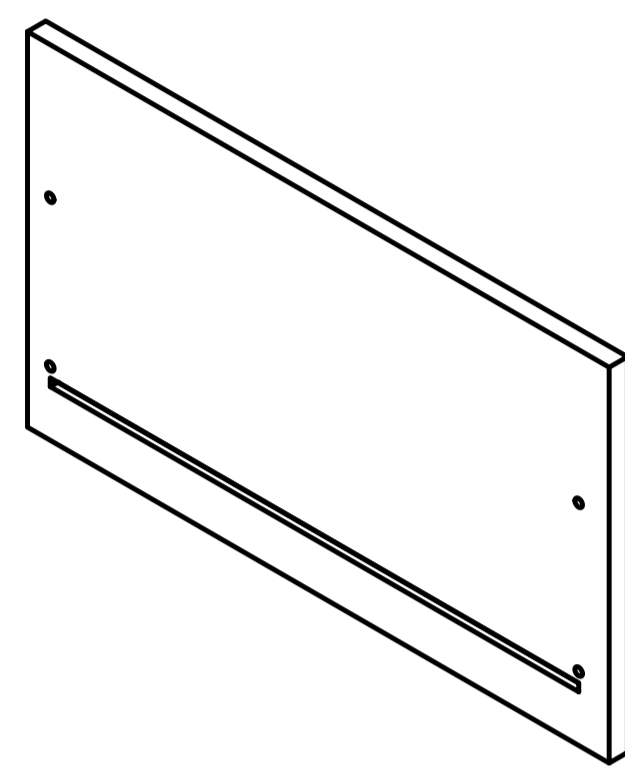

F x2

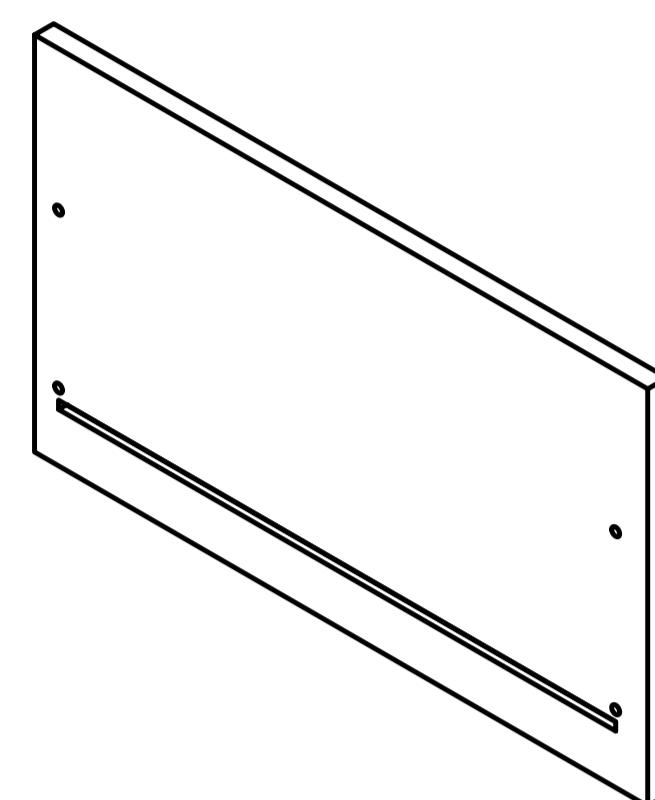

G x2

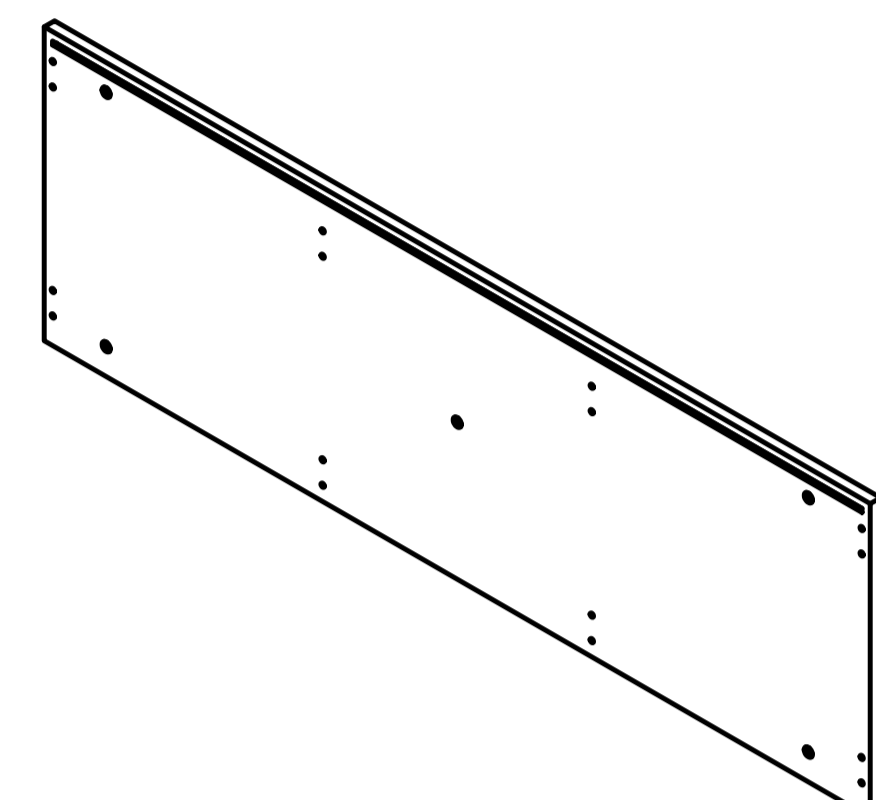

H x1

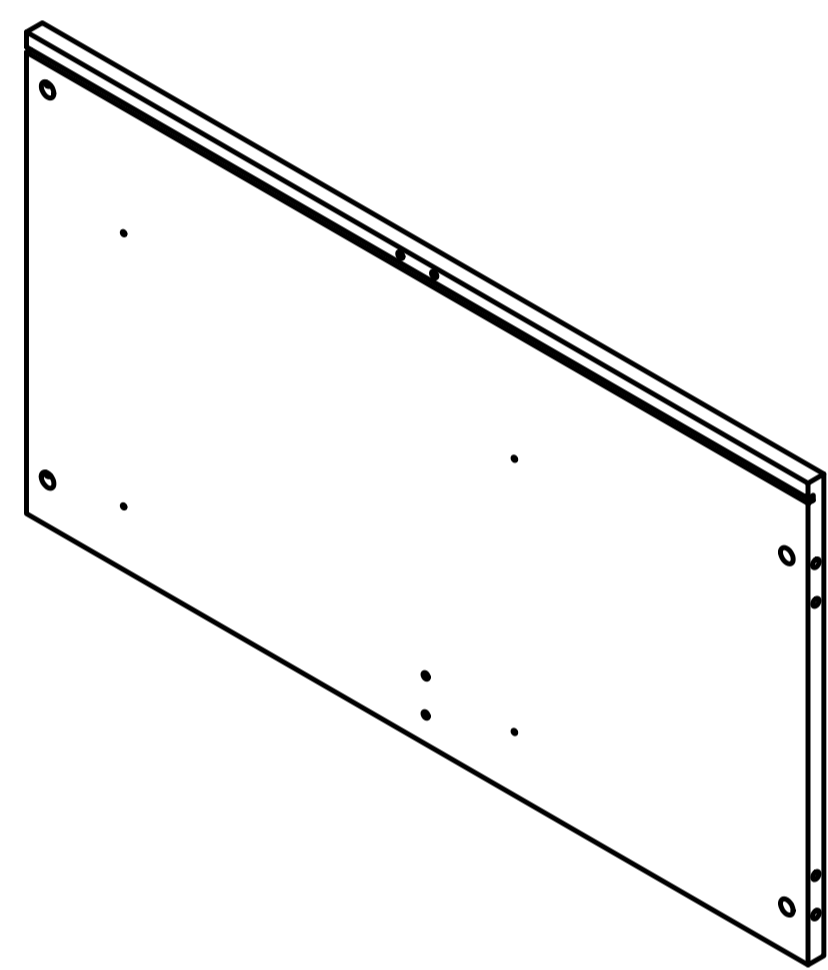

J x1

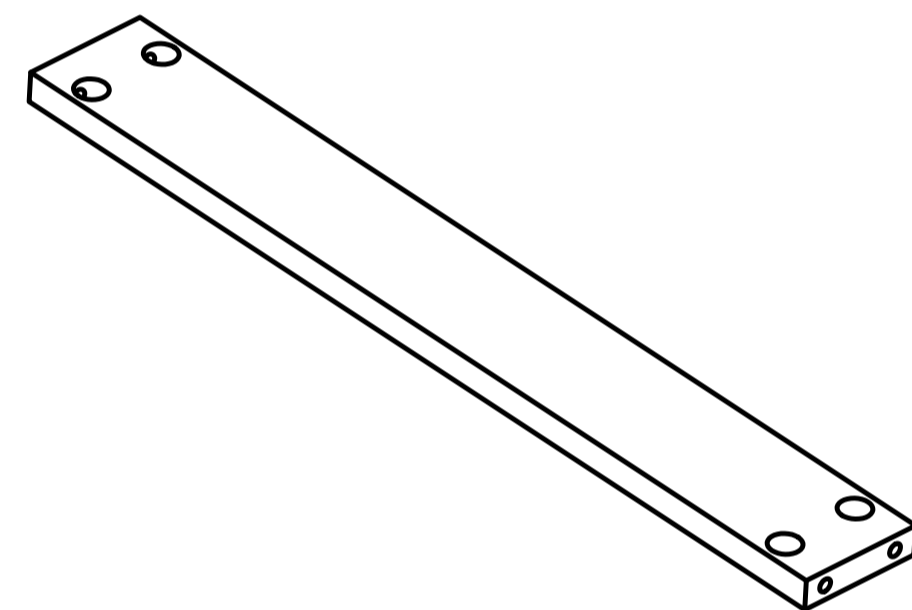

K x2

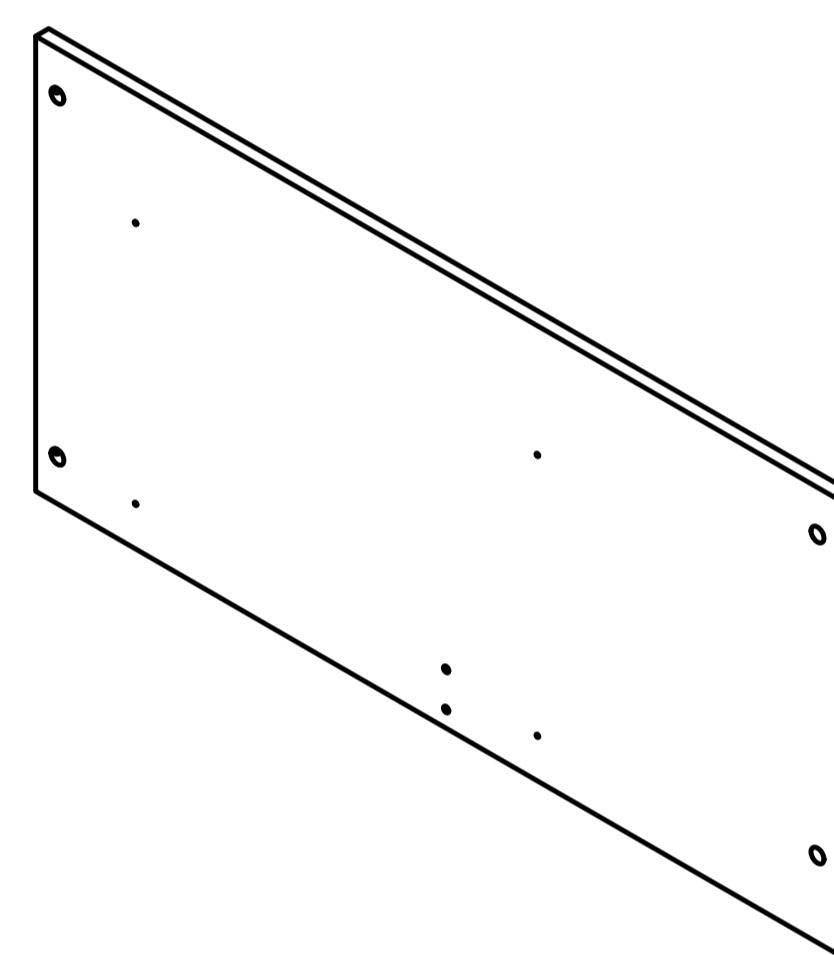

L x1

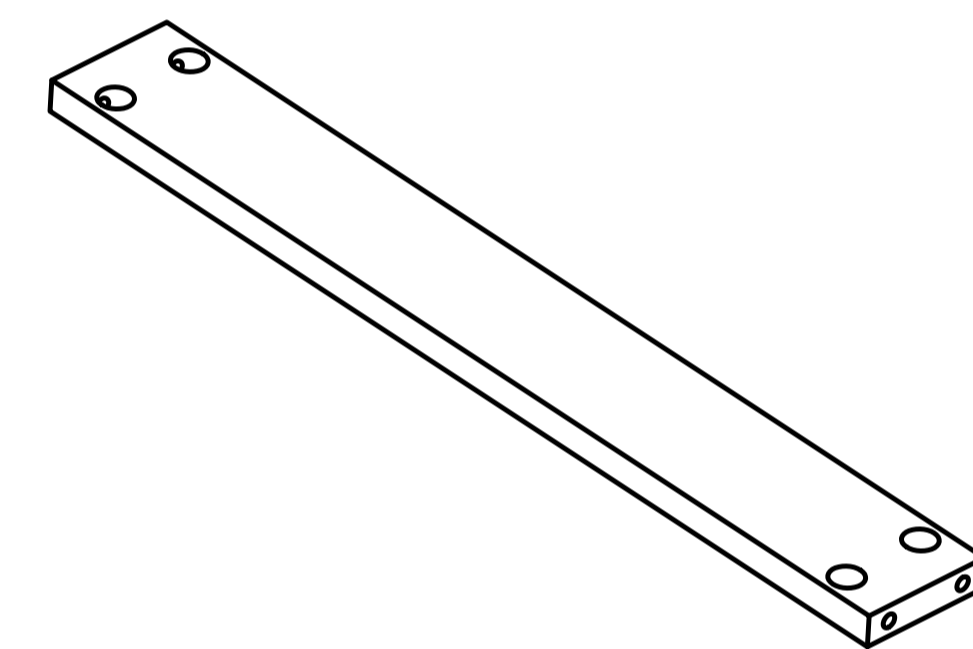

Mx1

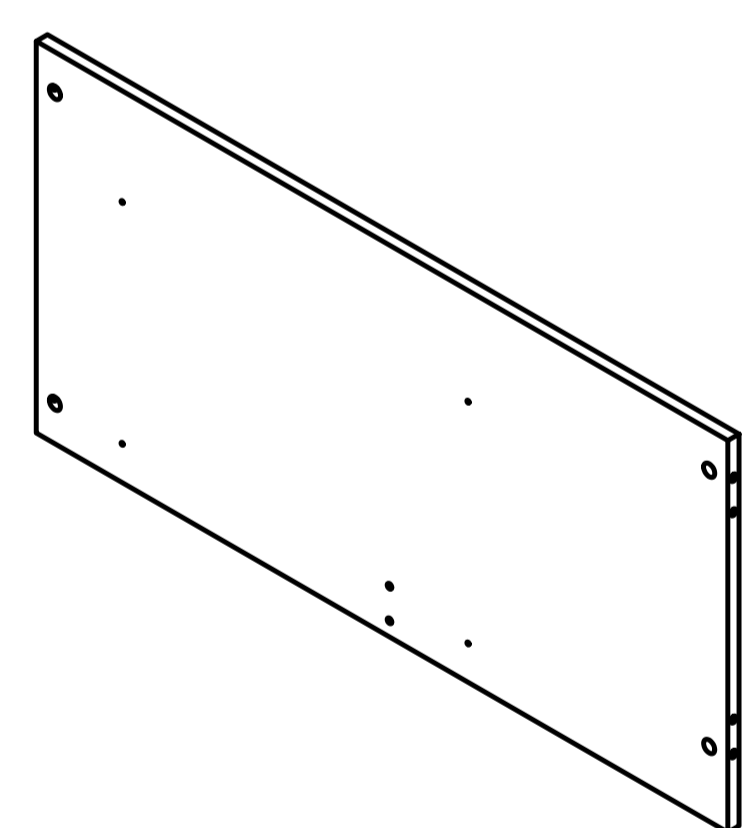

N x1

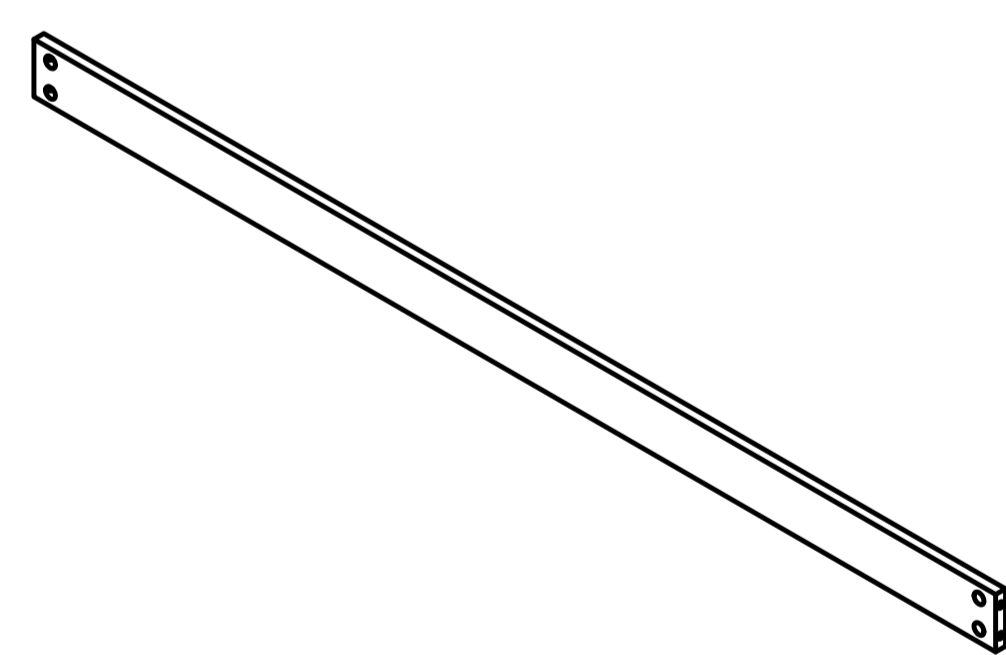

Ox1

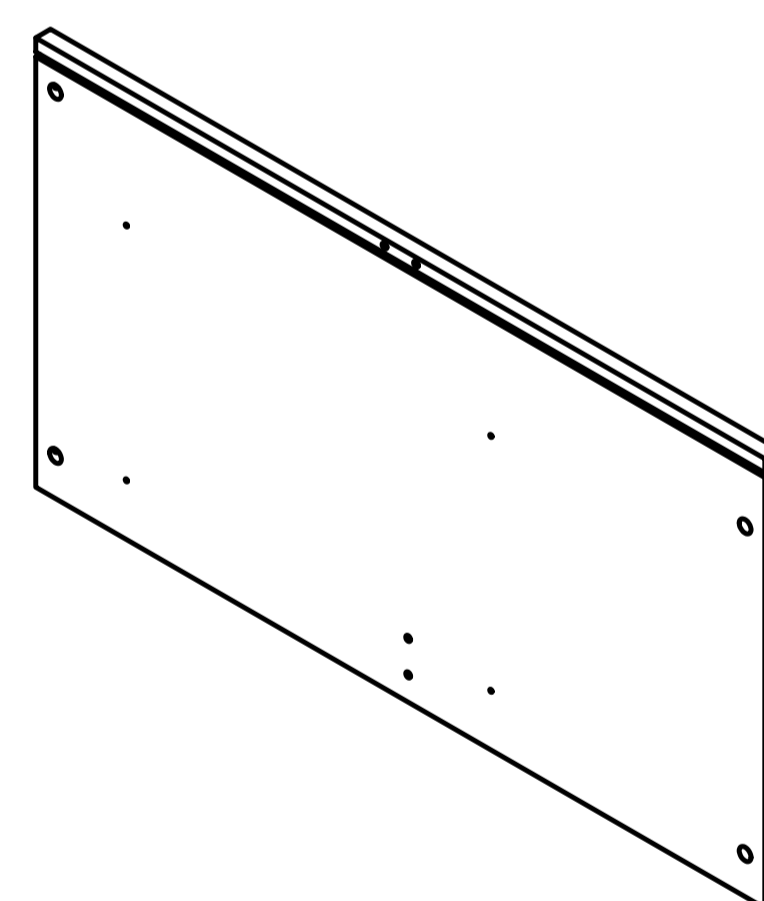

P x1

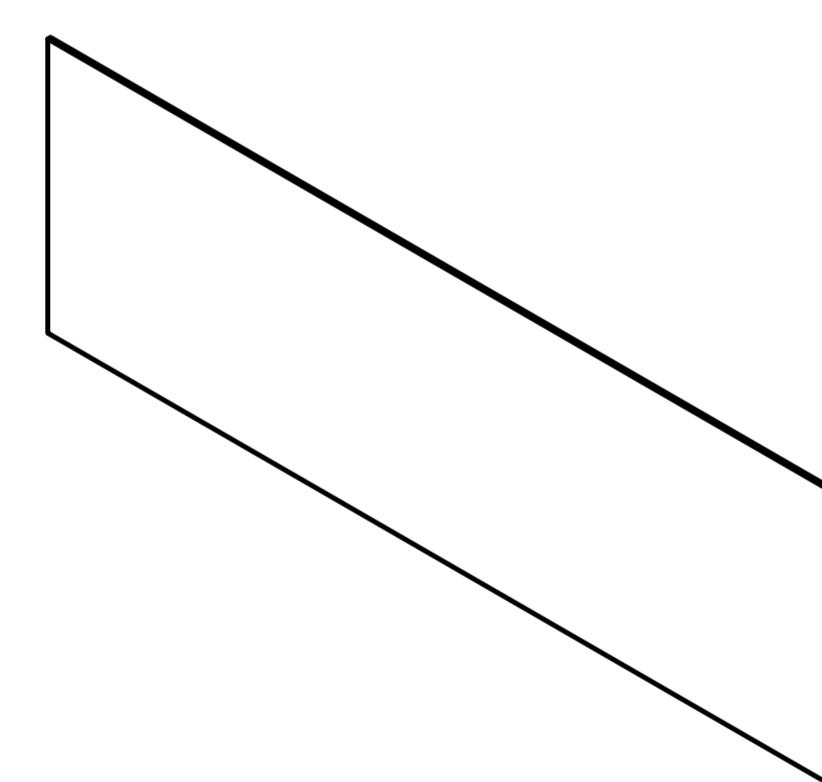



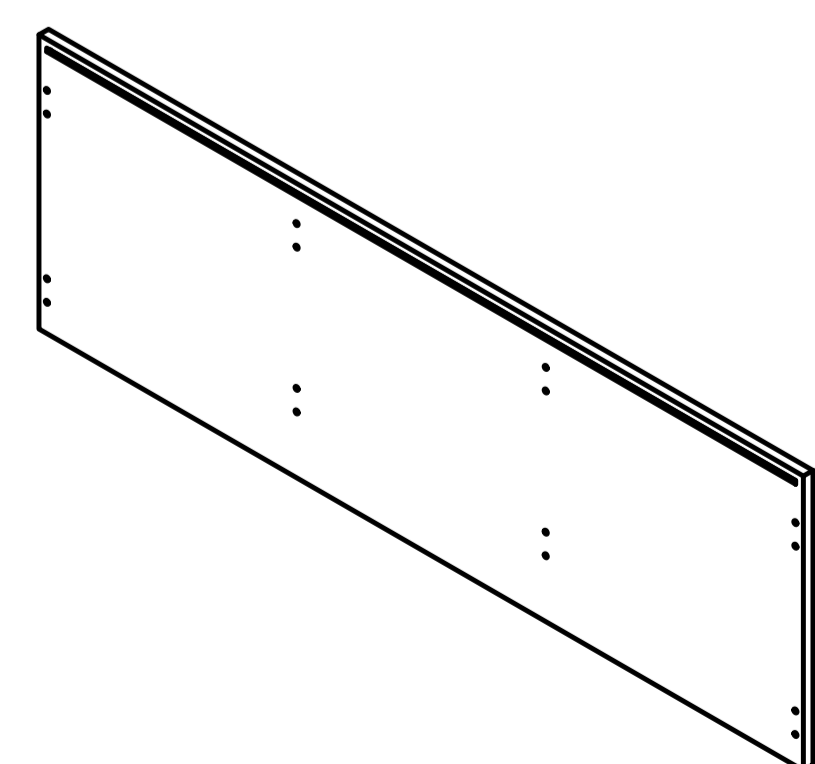

Qx2

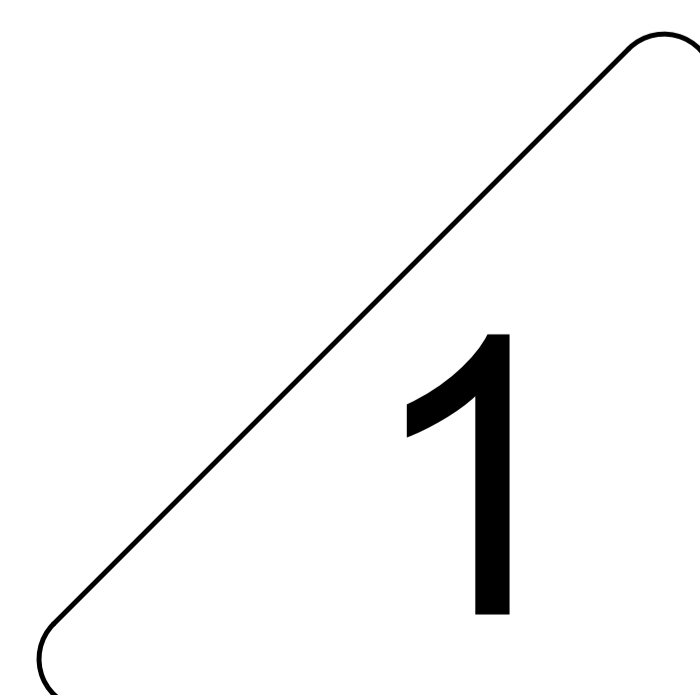

R x1

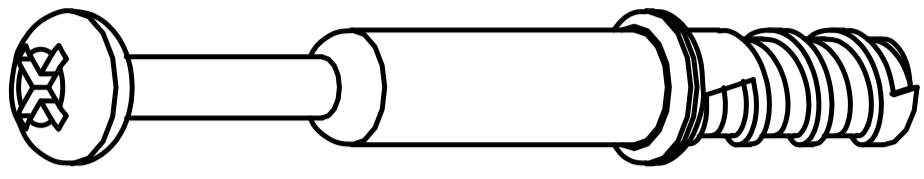
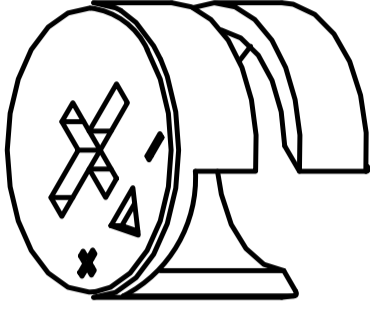

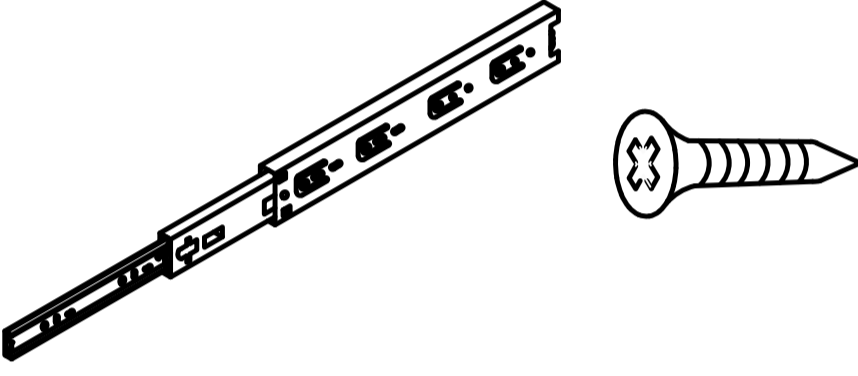
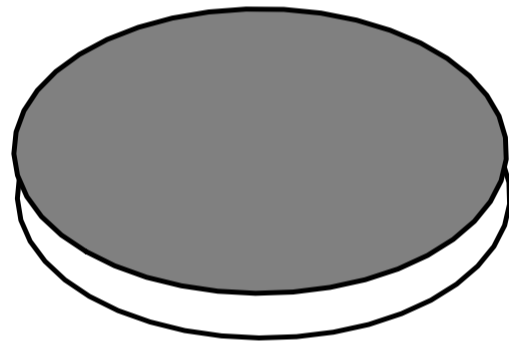
Accessories list

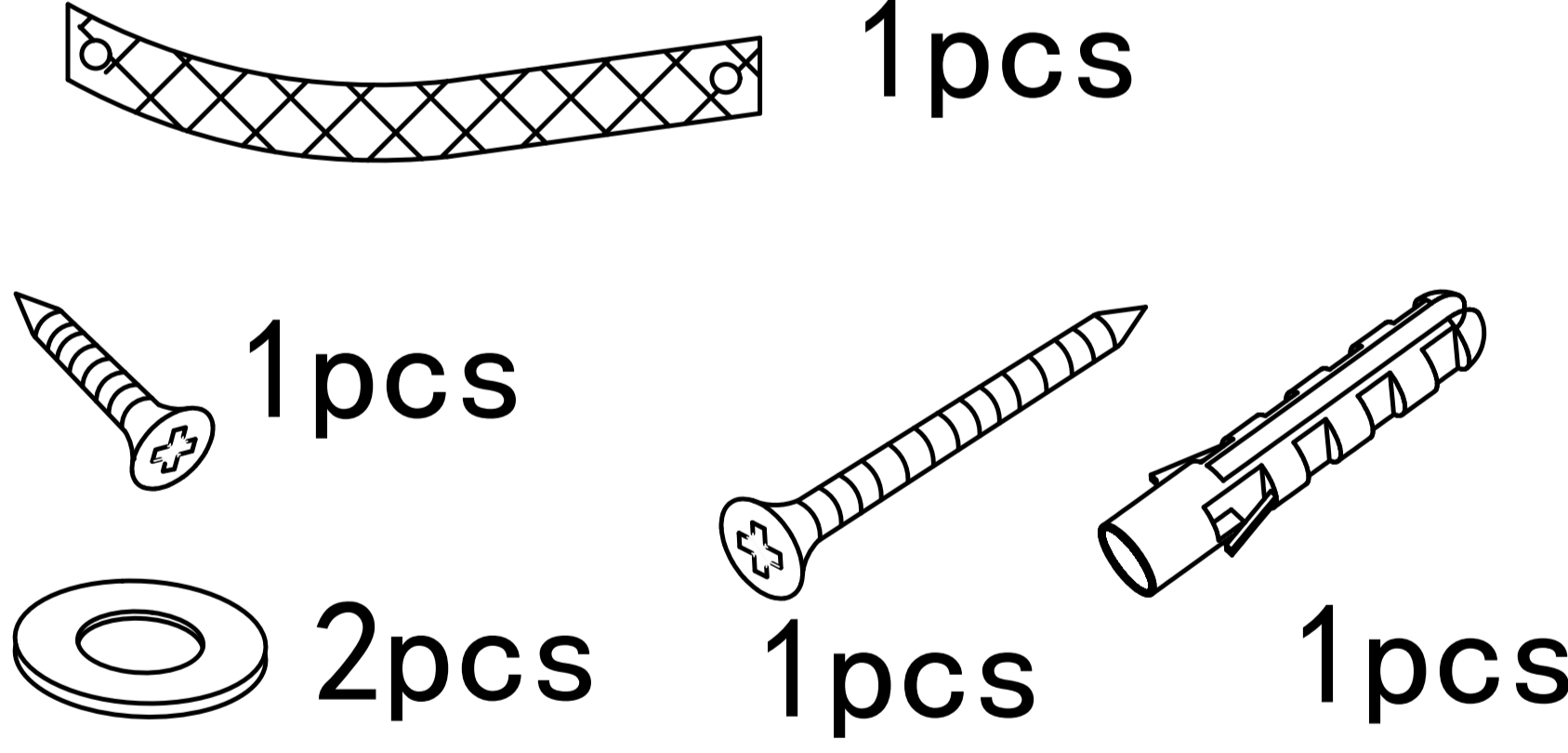
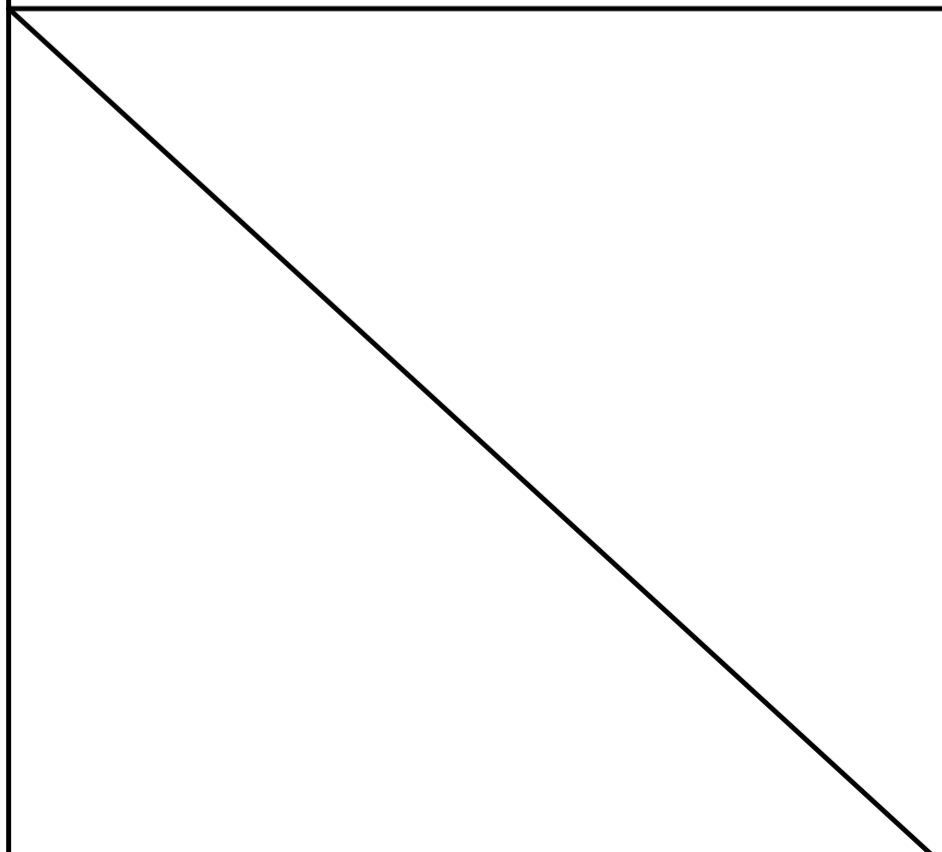
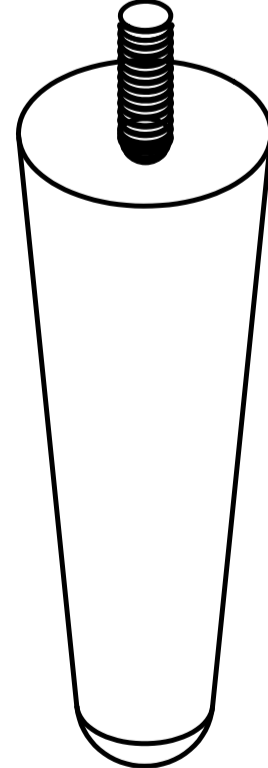
<p>①</p>		<p>Two In One Screw (6x28mm)</p>	<p>104pcs +10pcs</p>
<p>②</p>		<p>Two In One Nut (10x12mm)</p>	<p>104pcs +10pcs</p>
<p>③</p>		<p>Wood Chipping (6x30mm)</p>	<p>16pcs +3pcs</p>
<p>④</p>		<p>Guide rails & screws (3x12mm) 29cm</p>	<p>60pcs +12pcs 12pcs</p>
<p>⑤</p>		<p>Non-slip pads (φ12x2mm)</p>	<p>5pcs +1pcs</p>
<p>⑥</p>		<p>Fixing Clip & Screw (3x16mm)</p>	<p>12pcs +1pcs</p>
<p>⑦</p>		<p>anti-tipping tape Screw & gasket (3.5x12mm) Screw (4x45mm)</p>	<p>1pcs</p>
		<p>wooden foot</p>	<p>5pcs</p>

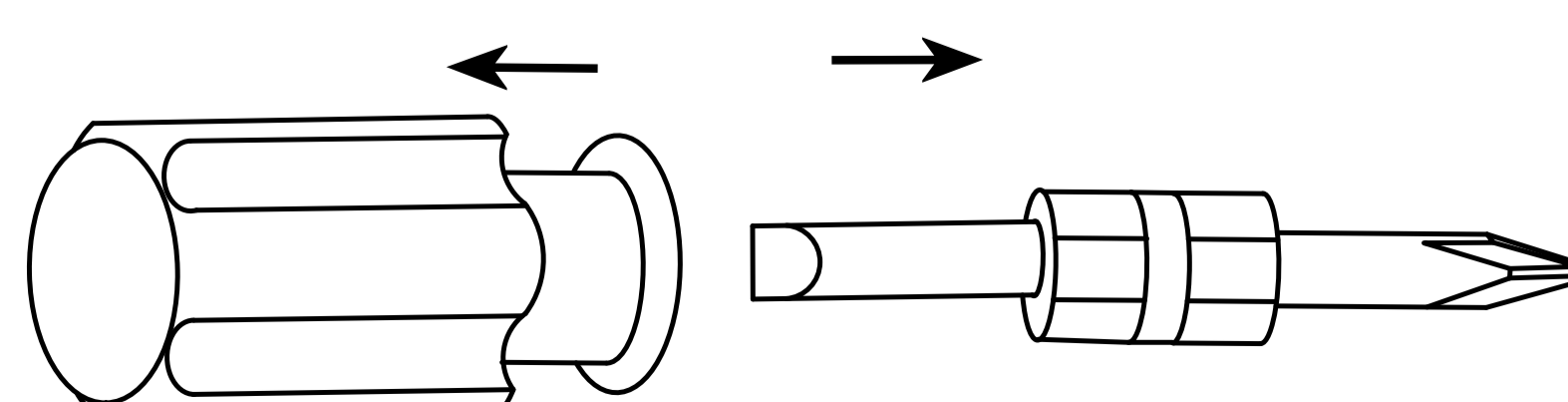
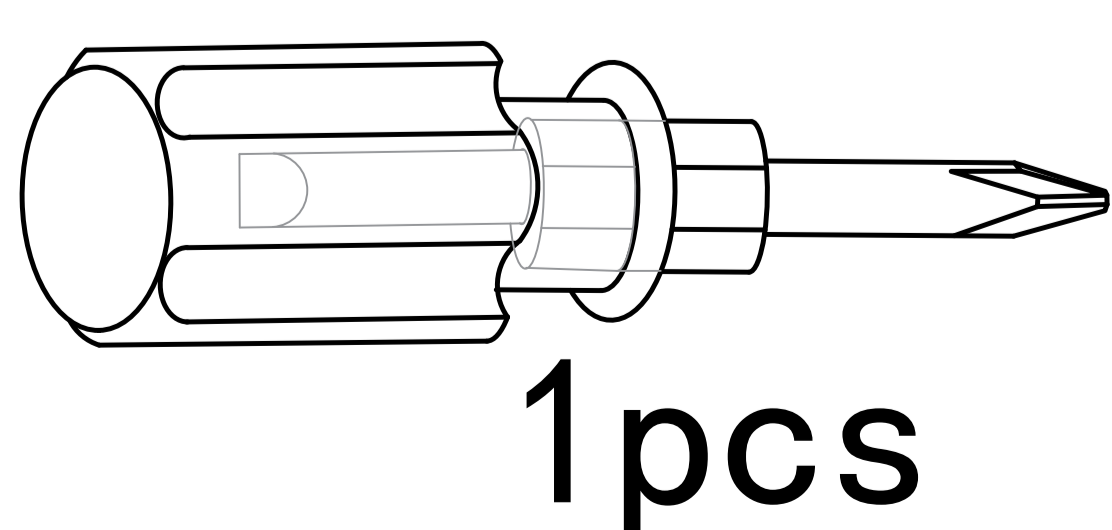

Double-head screwdriver, use as required

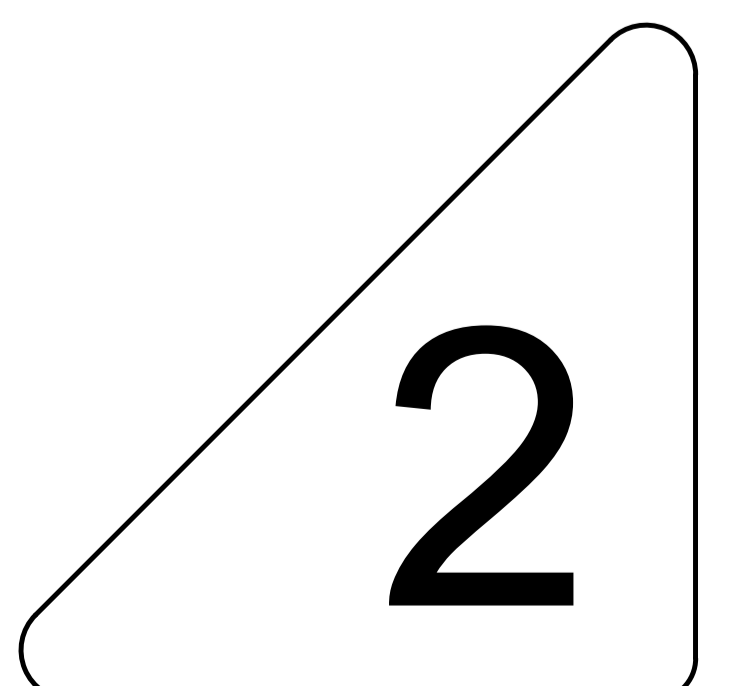

Product structure decomposition

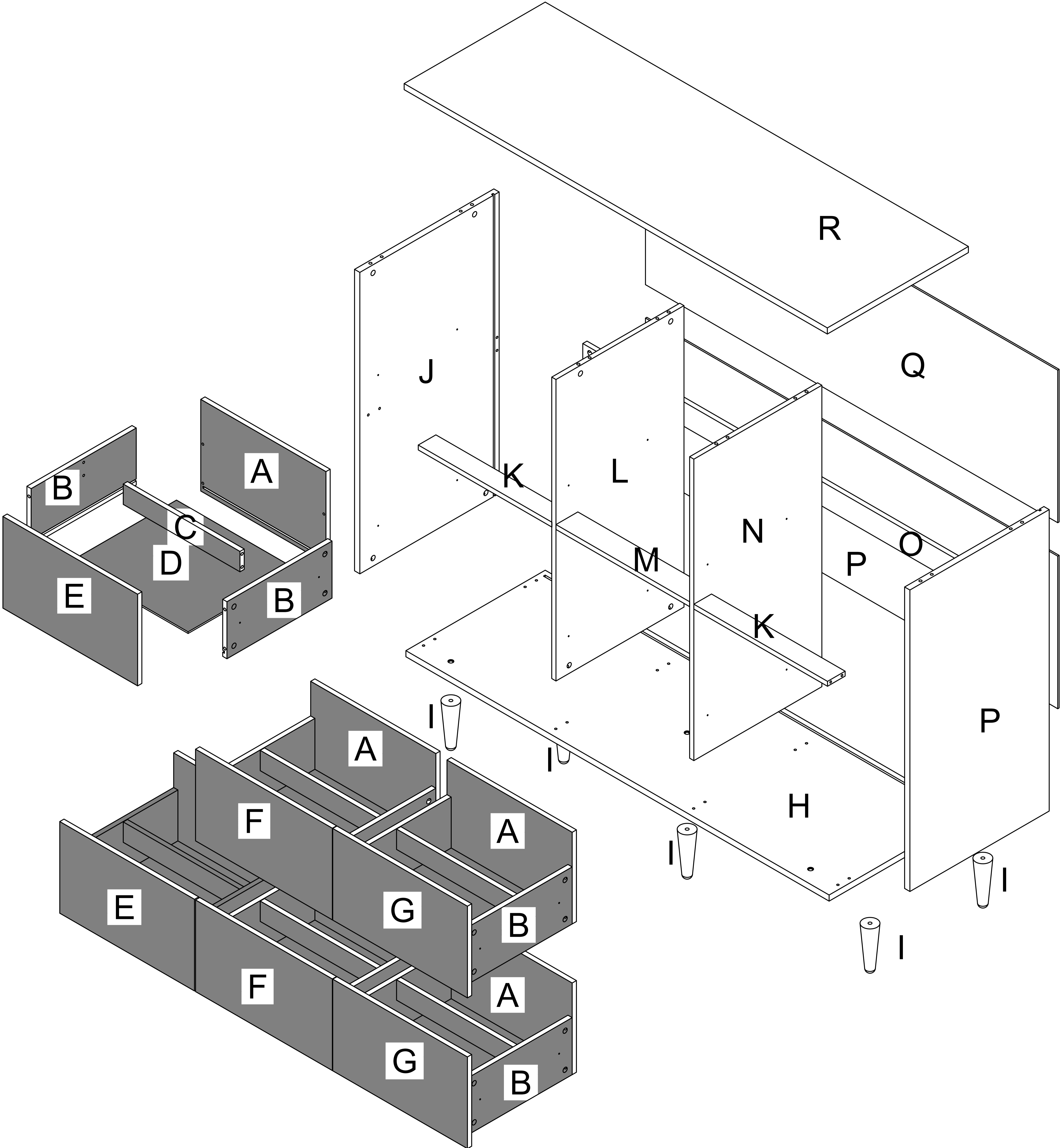

Use parts ① and ②

Step 1

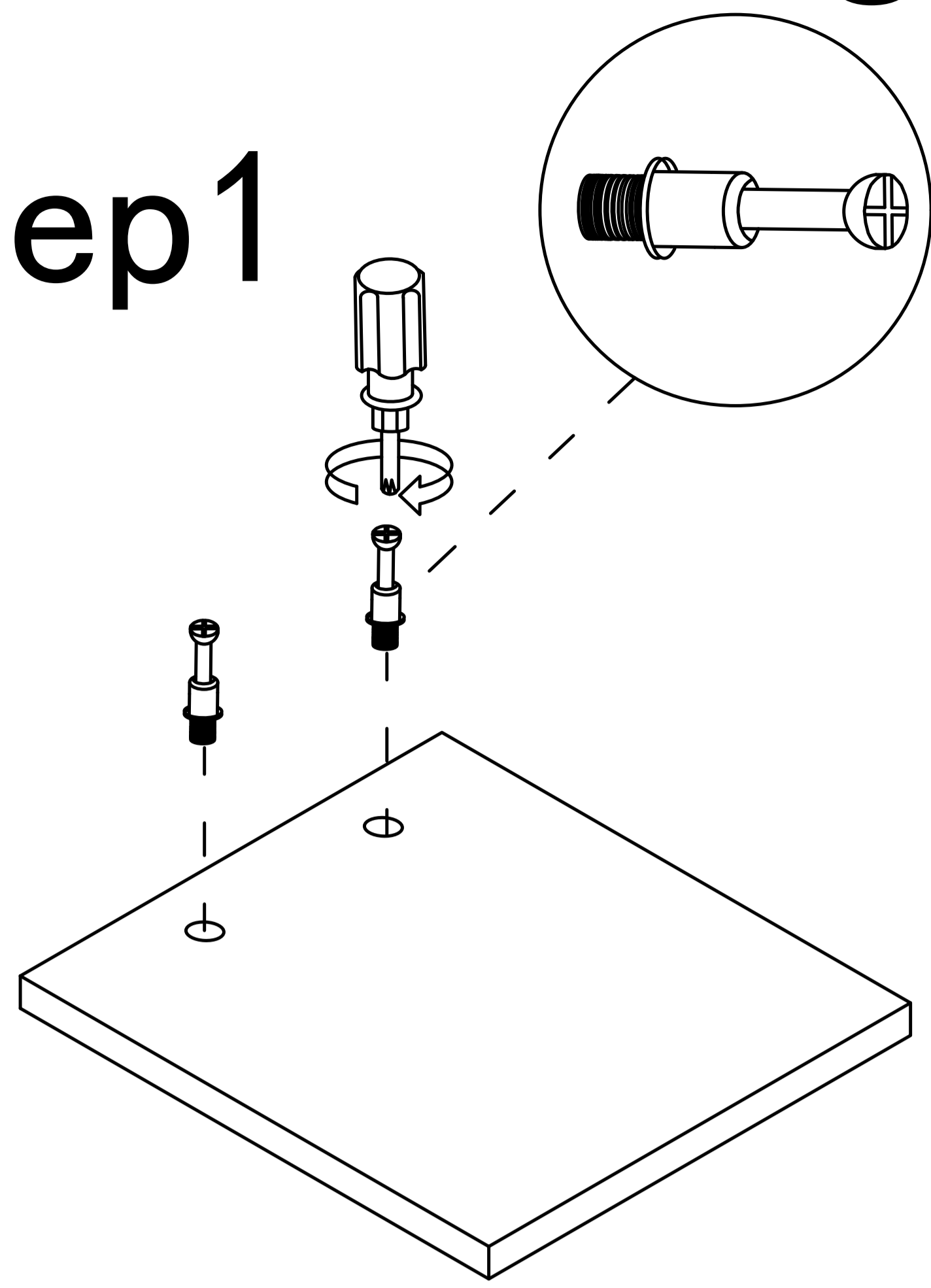

Step 2

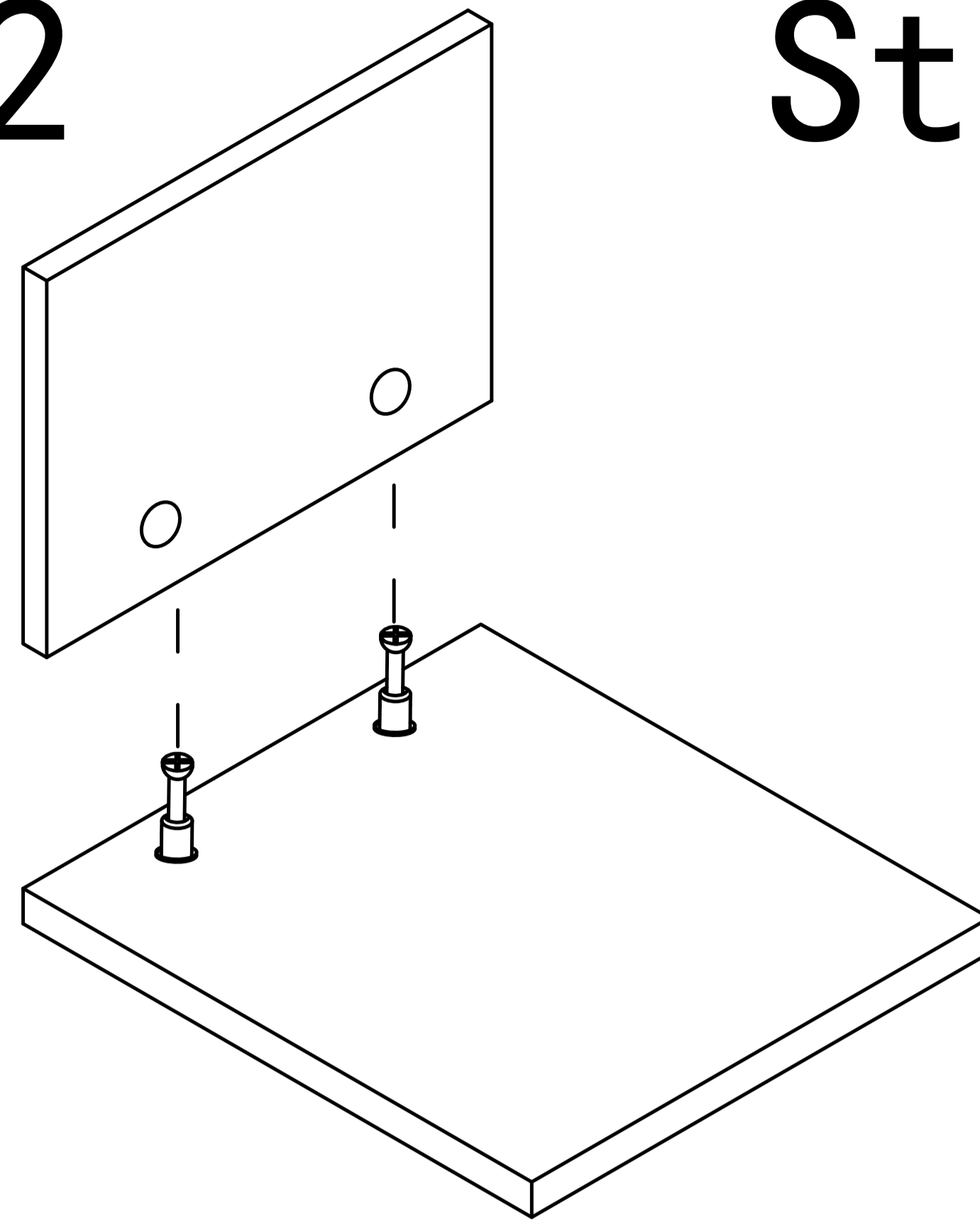

Step 3

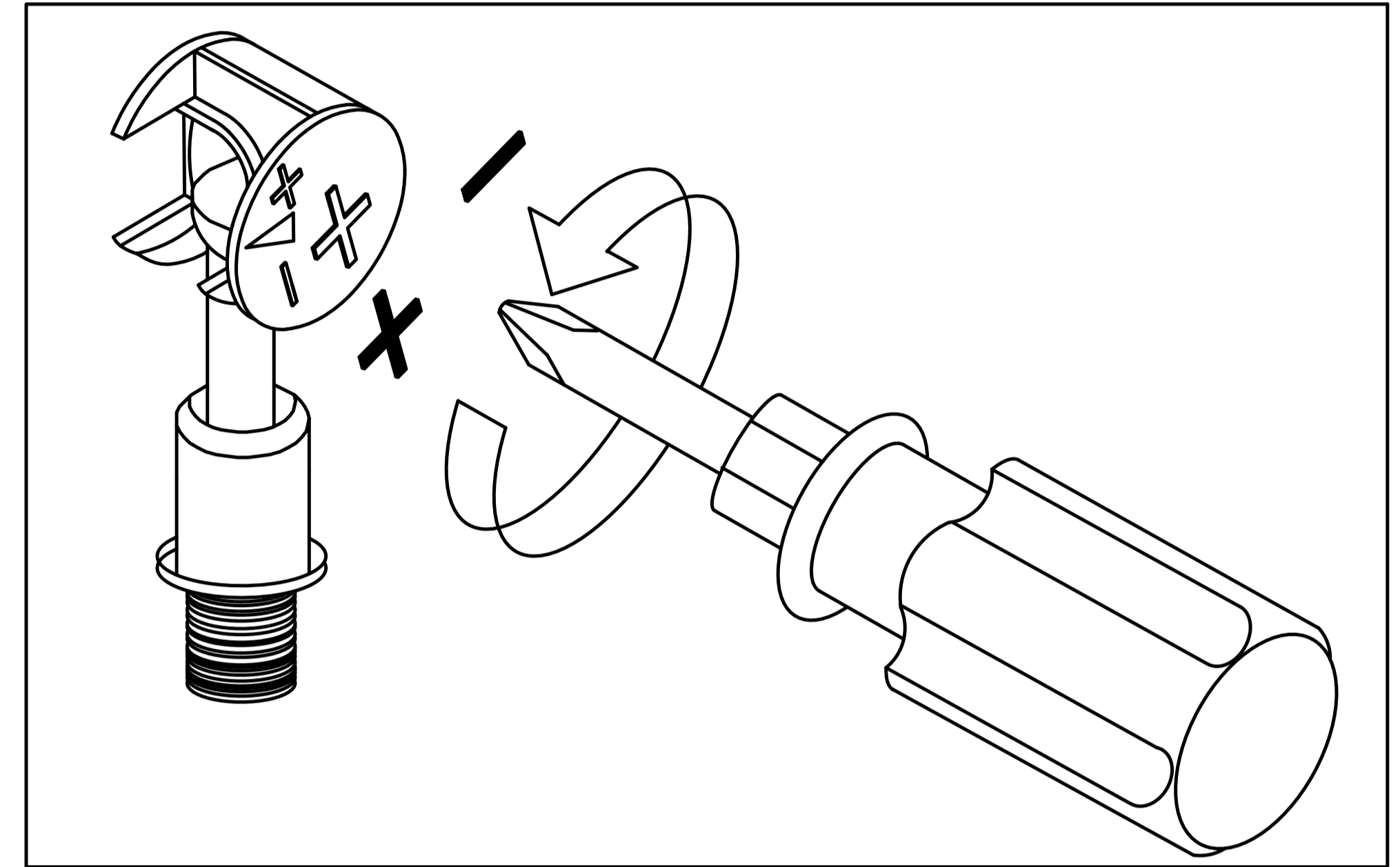
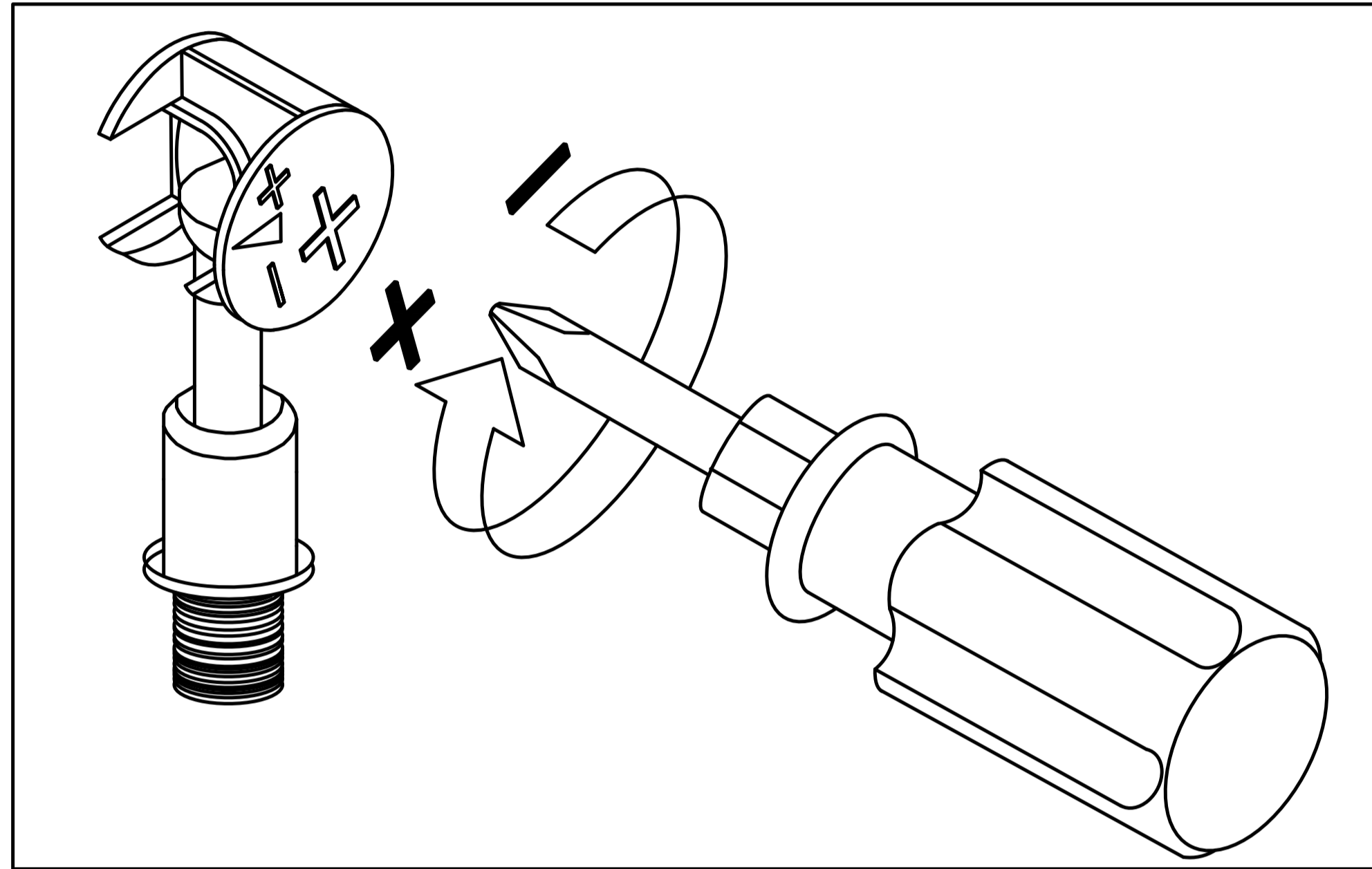
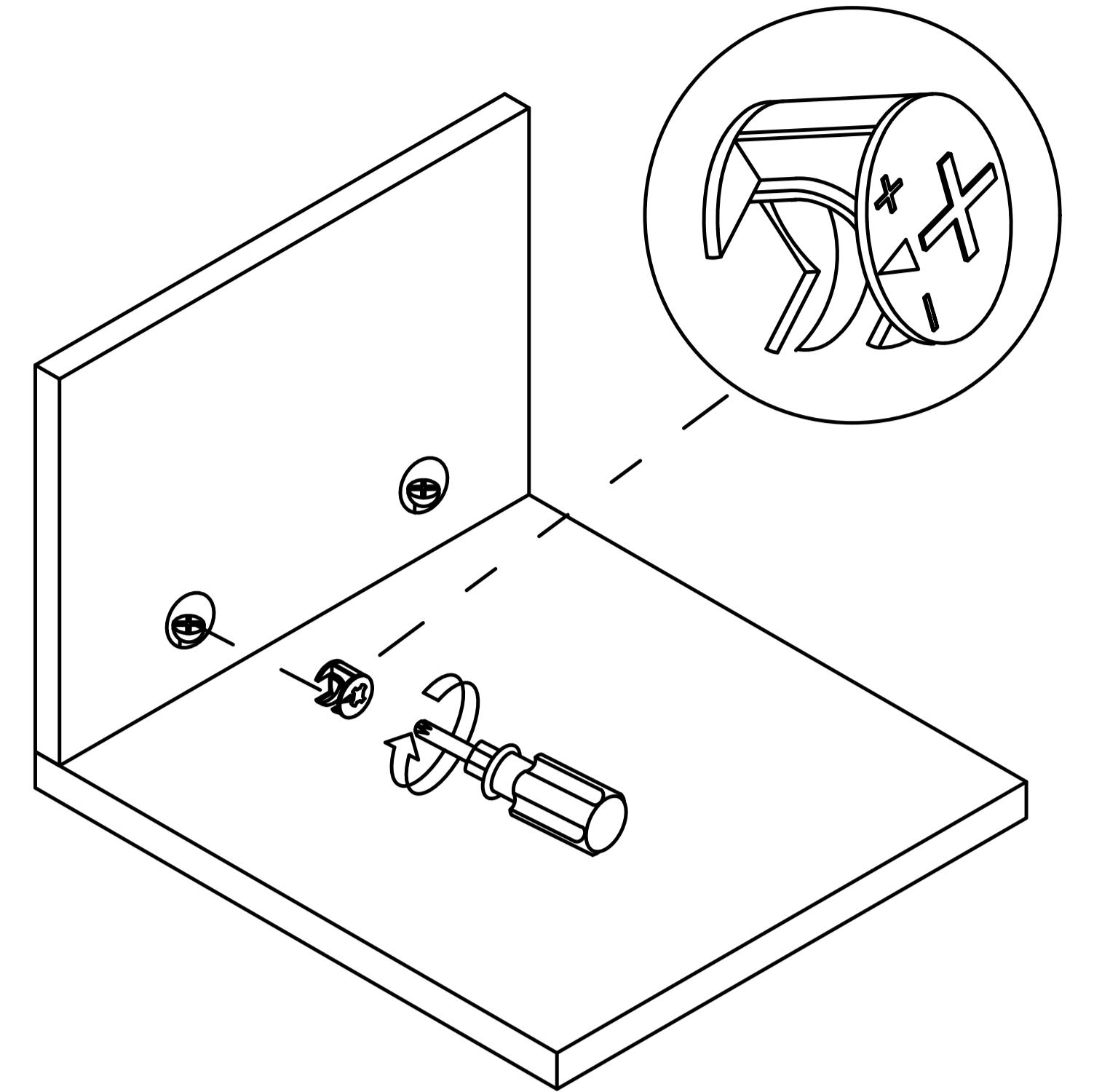

Use a screwdriver to lock in the direction of the "+" sign

Disassemble along the direction of "-" sign

Step 1

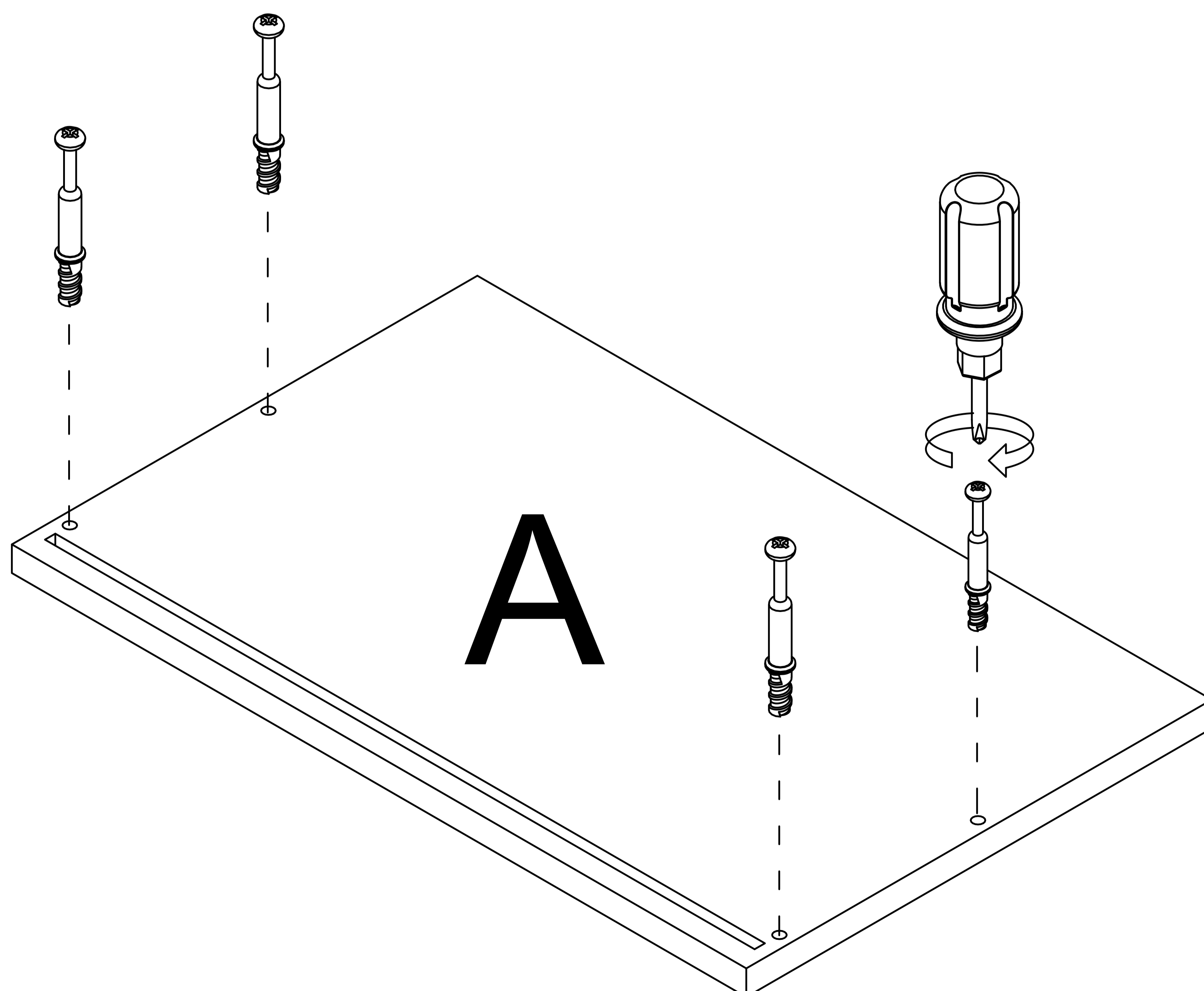
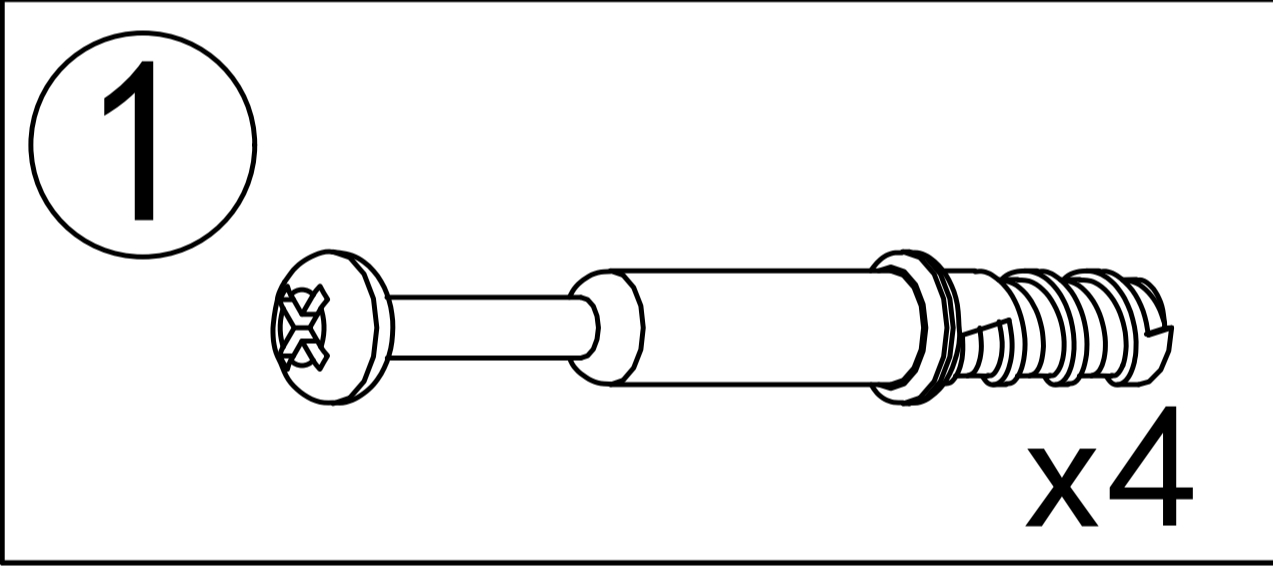

Step 2

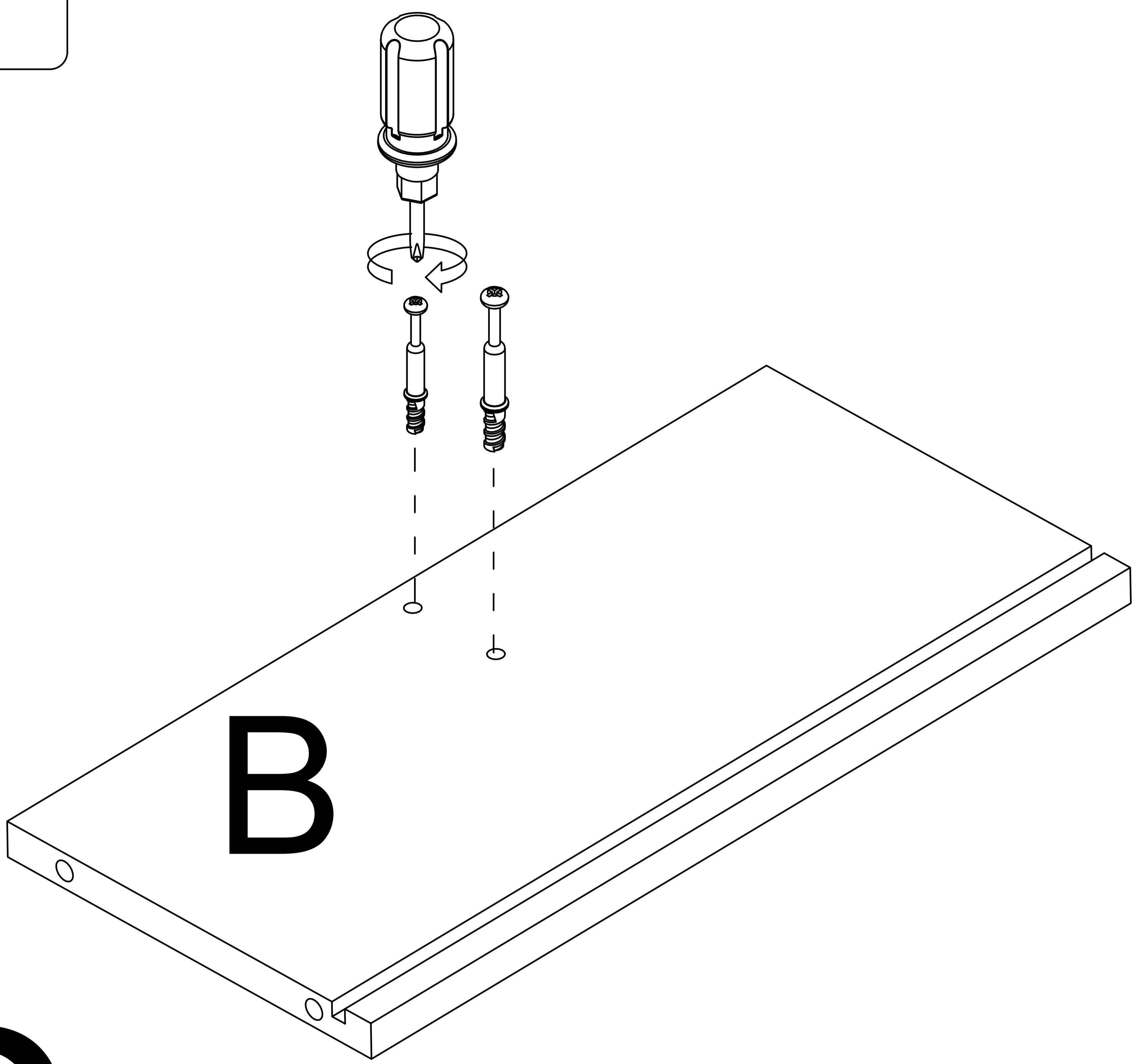
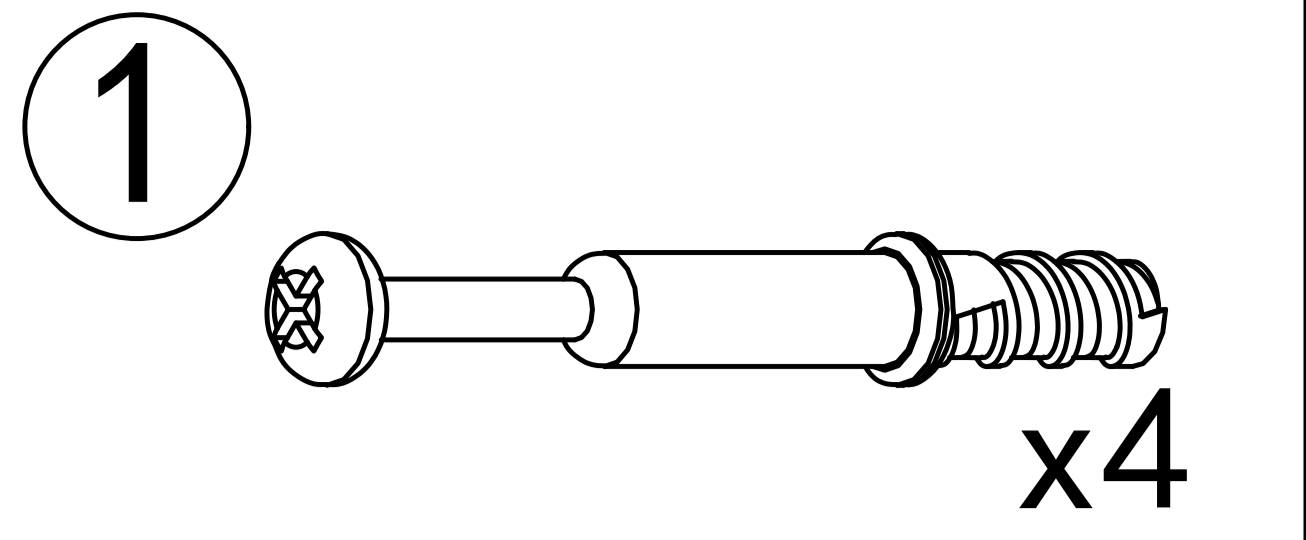

x 2

Step 3

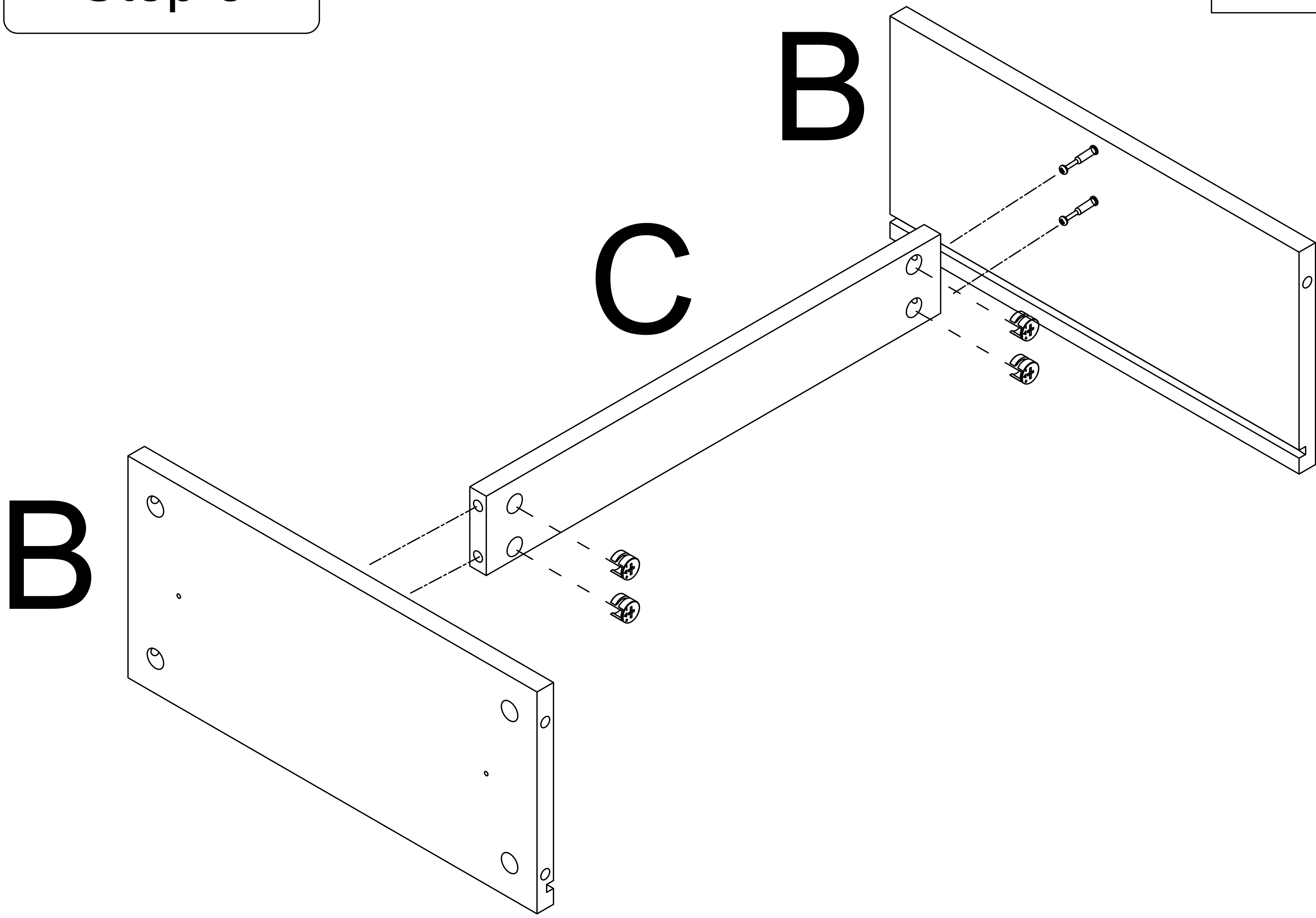
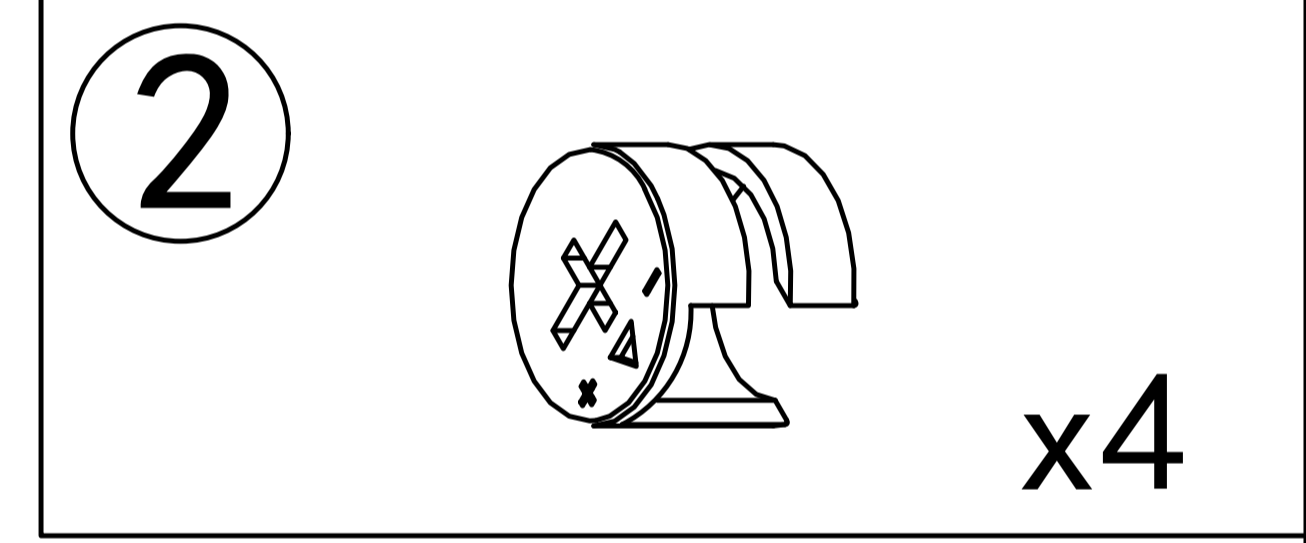

Step 4

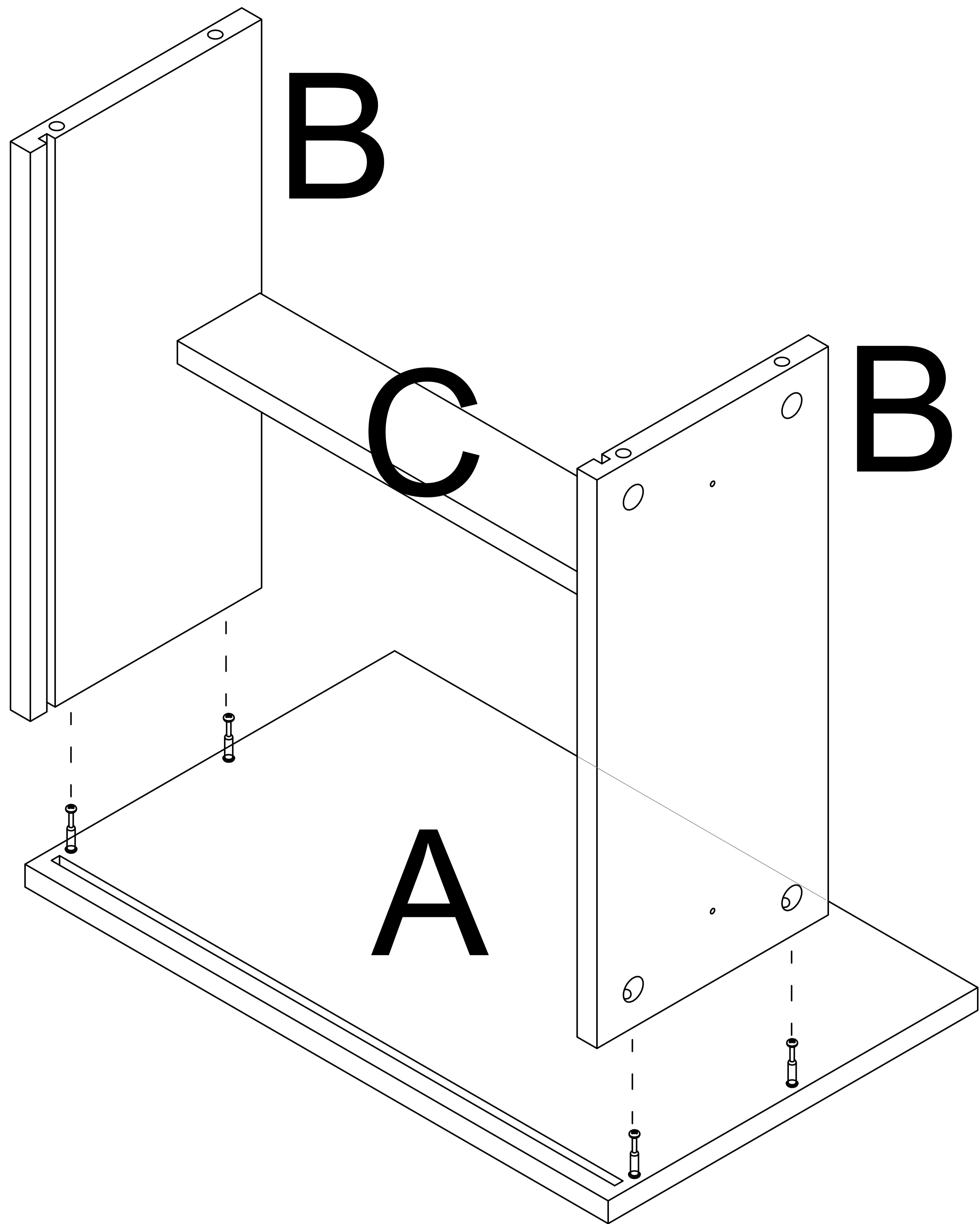

Step 5

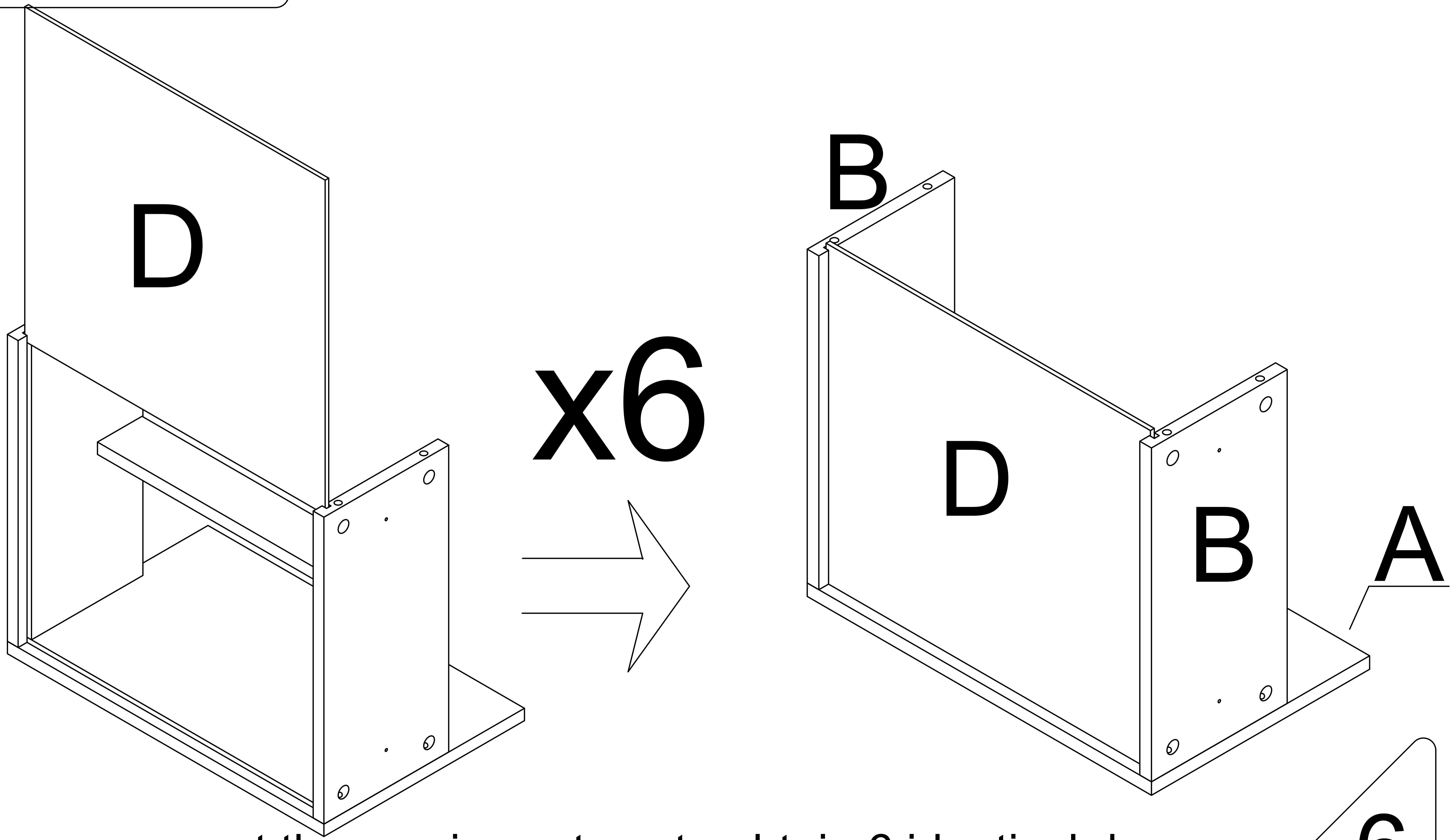
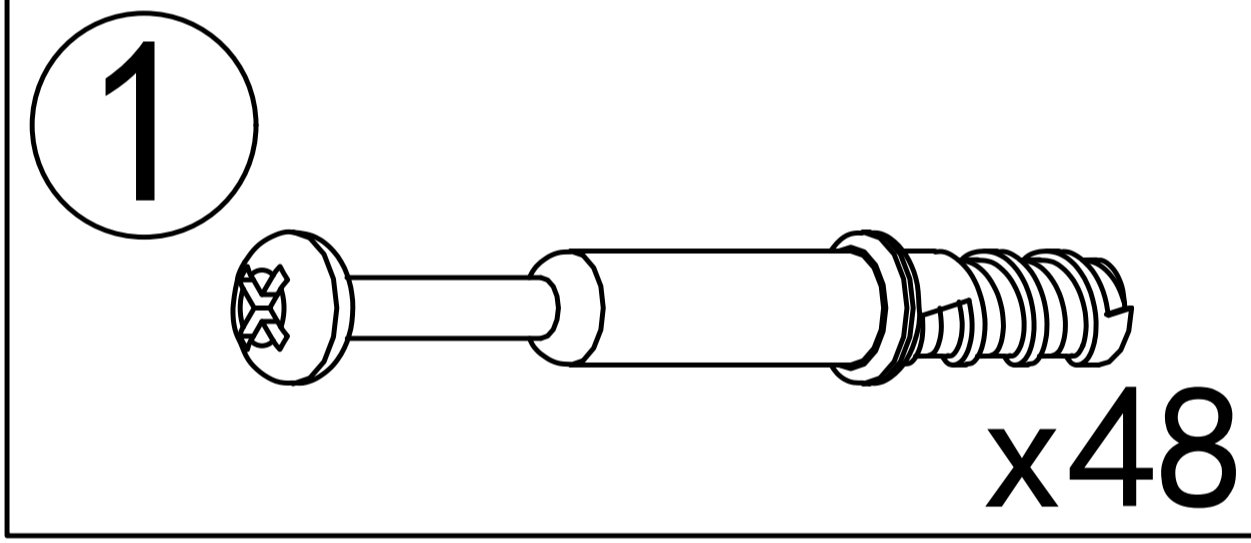

You can repeat the previous steps to obtain 6 identical drawers.

Step 6

1

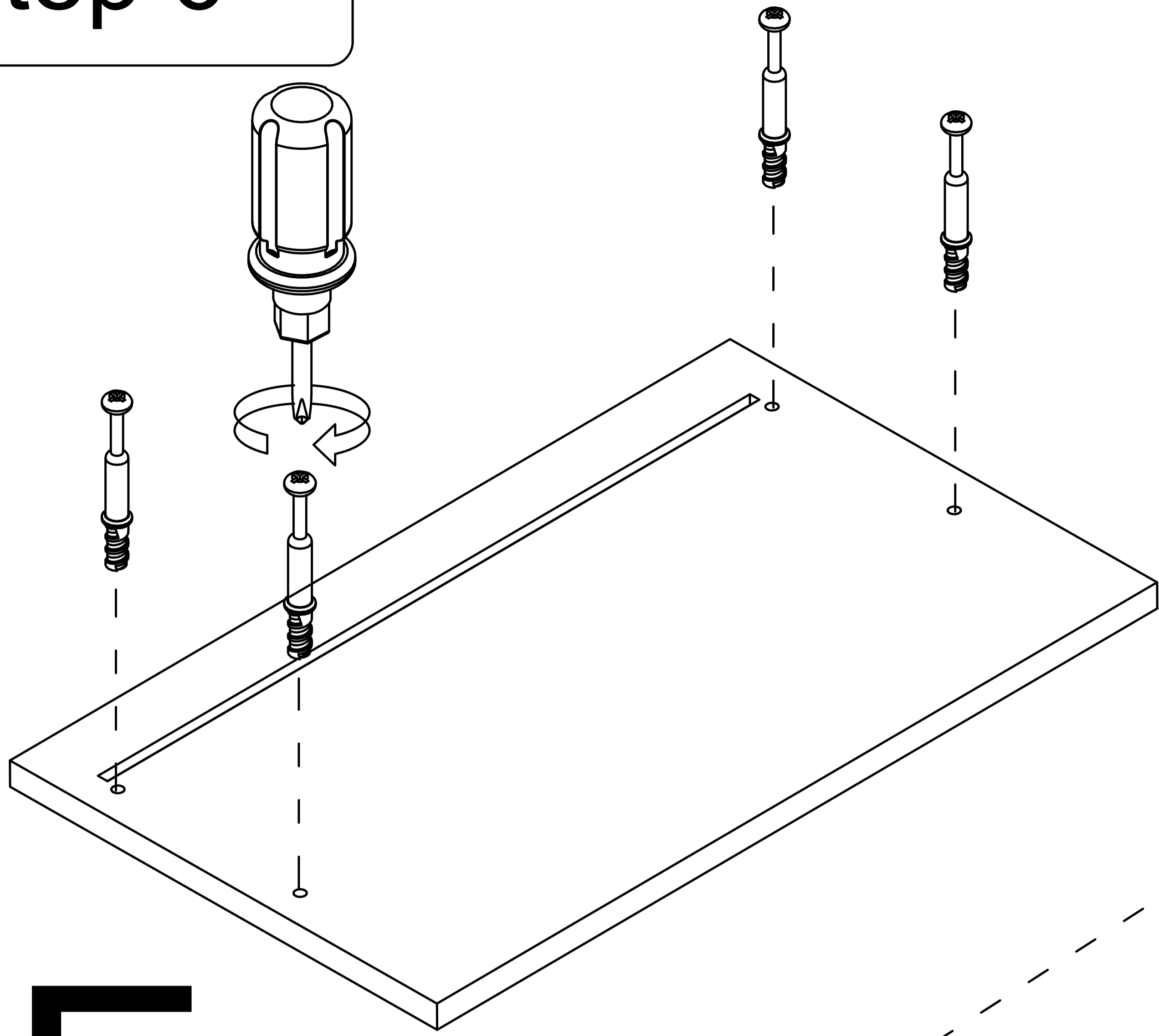
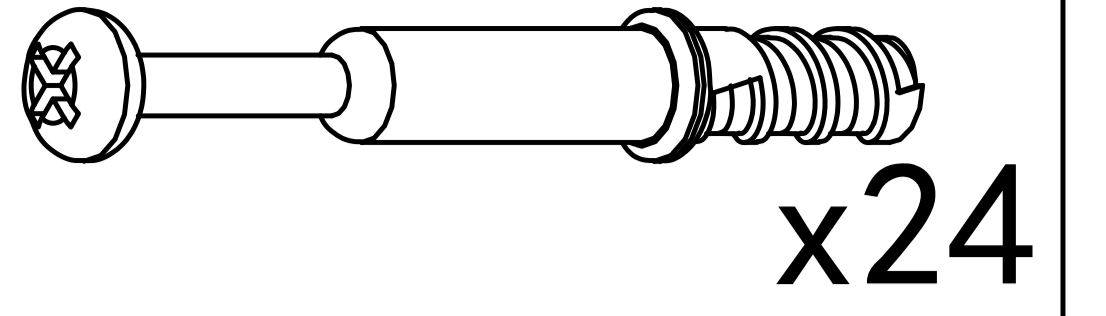

F

X 2

F

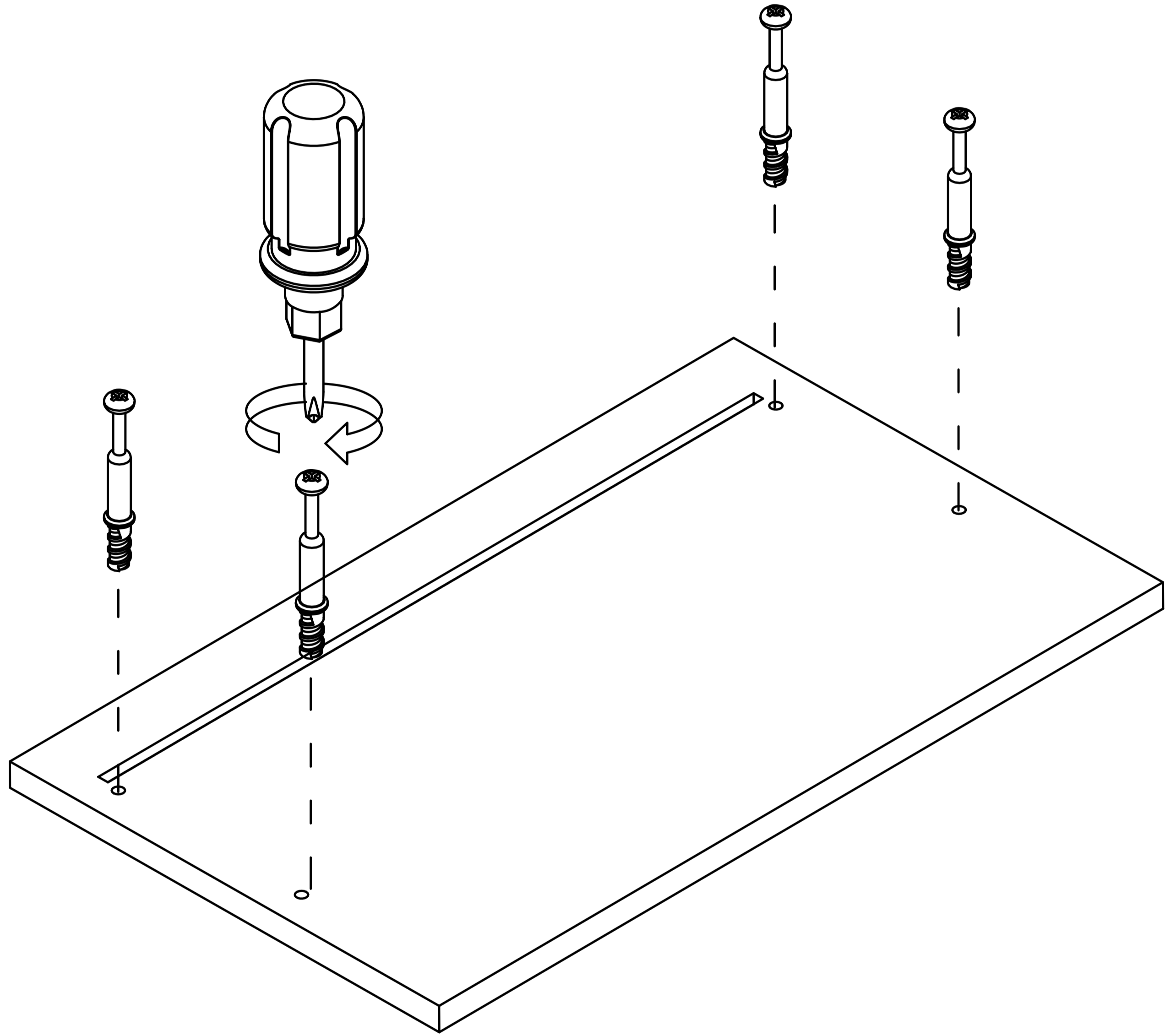

G

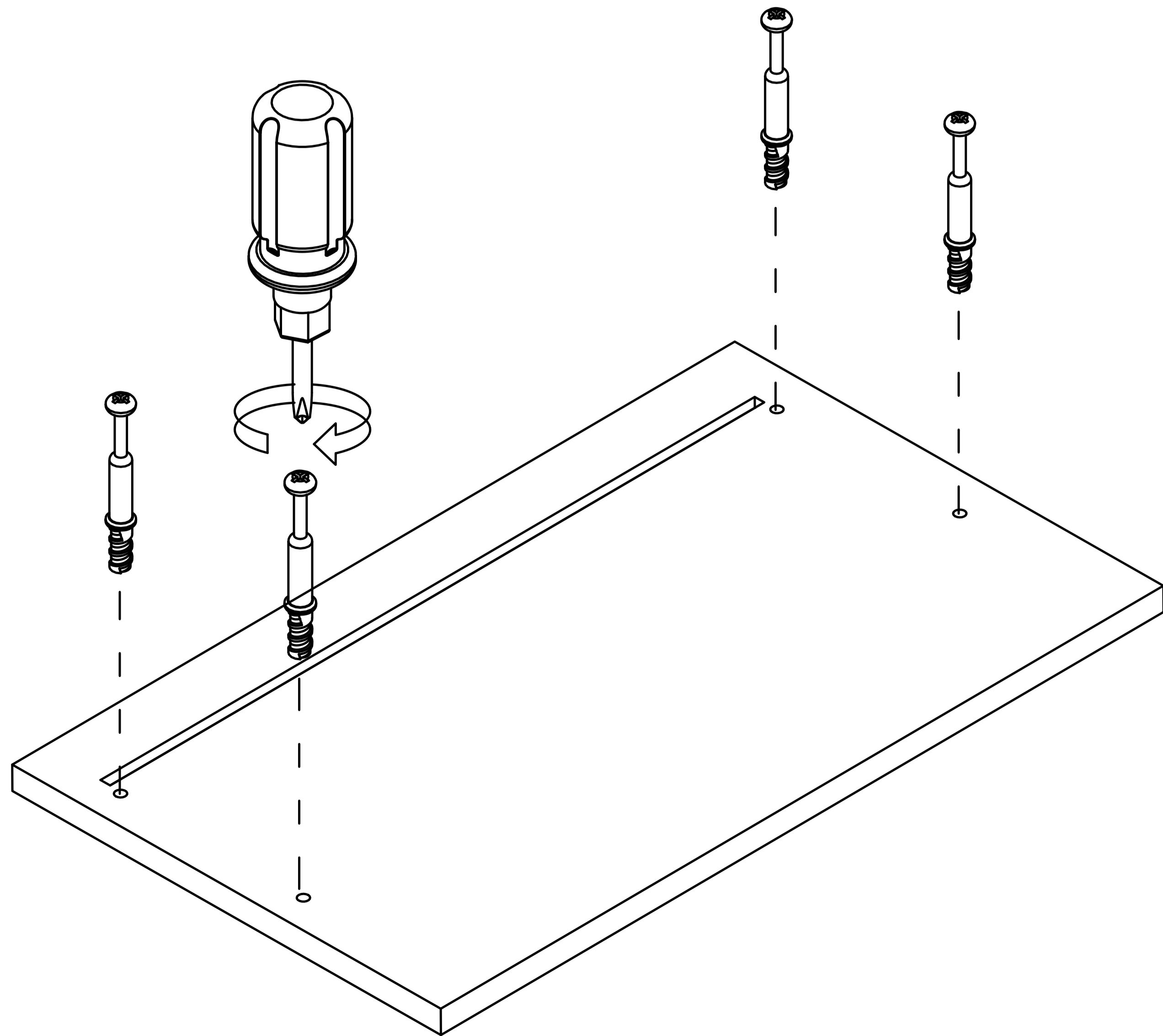

Step 7

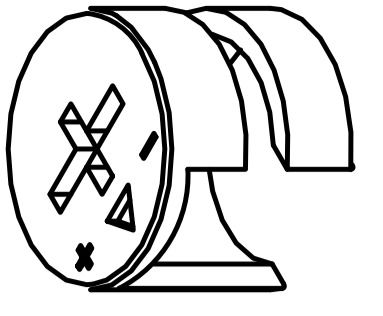
2  x68

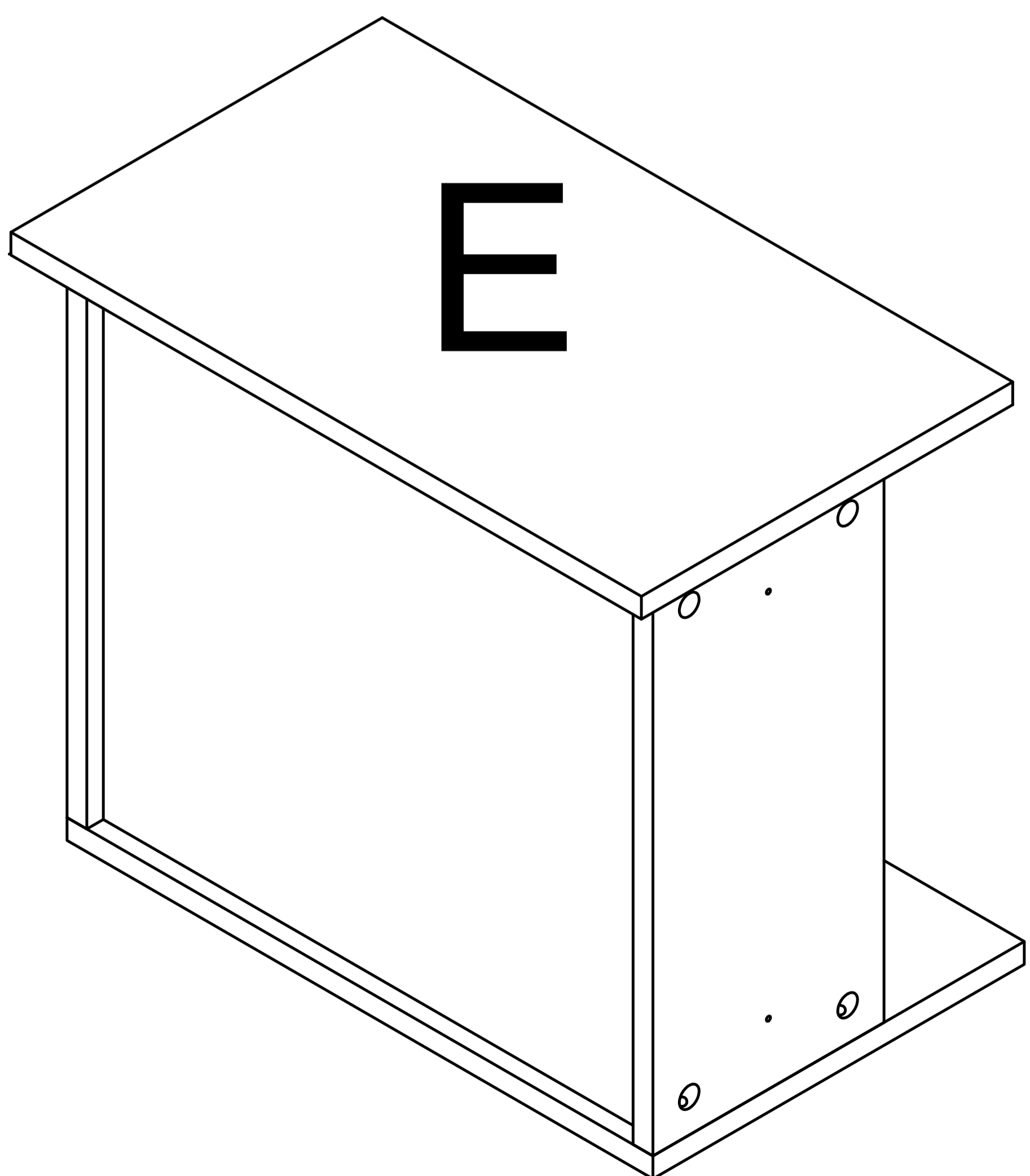
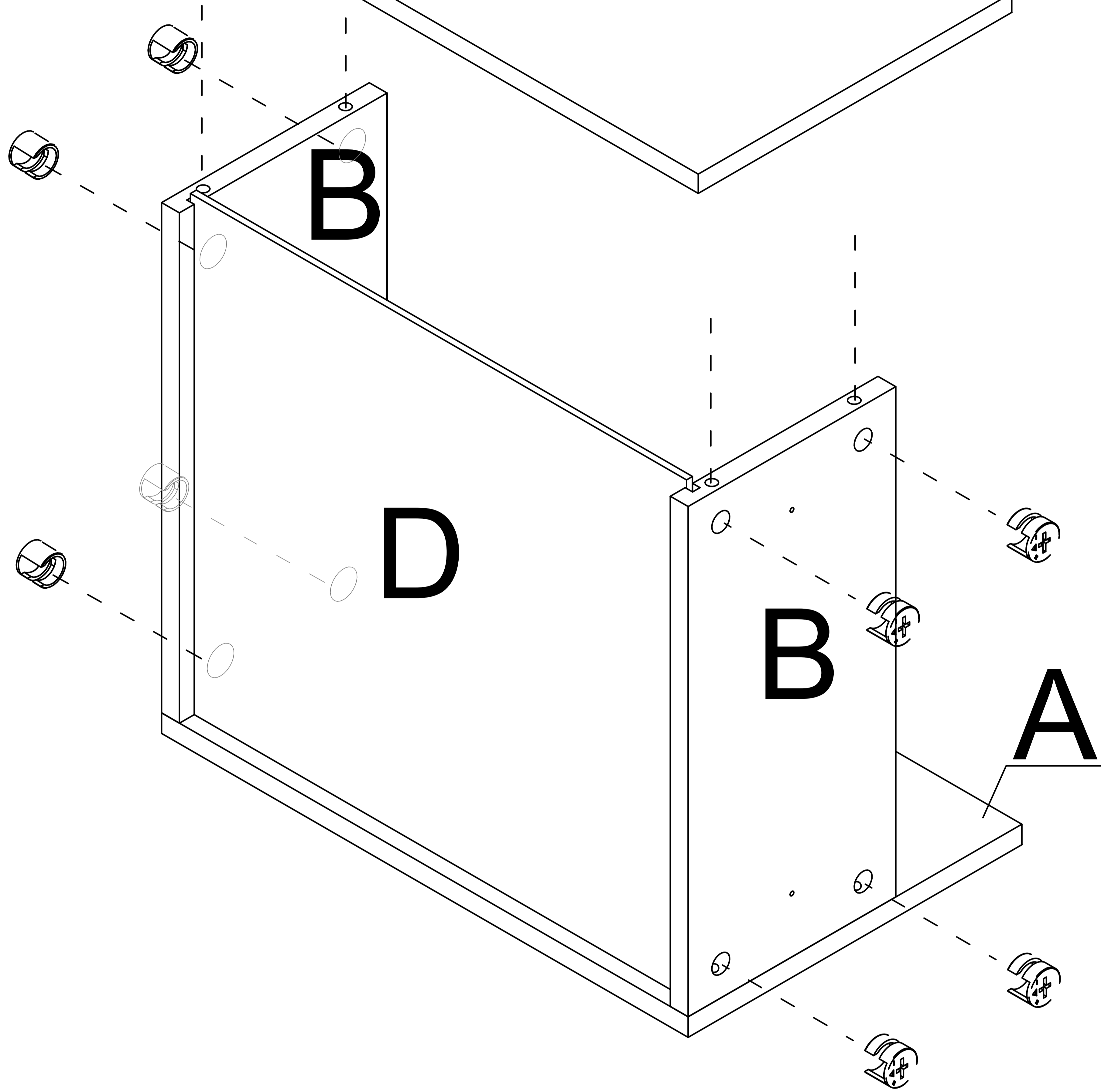
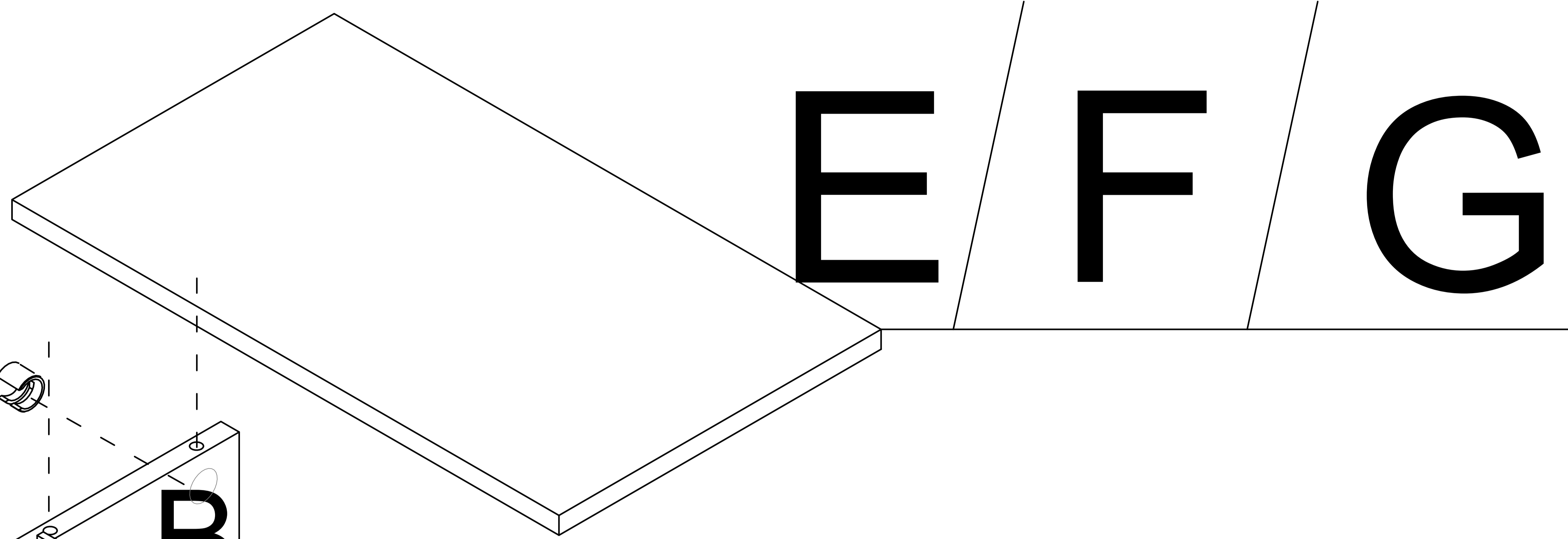

x 2

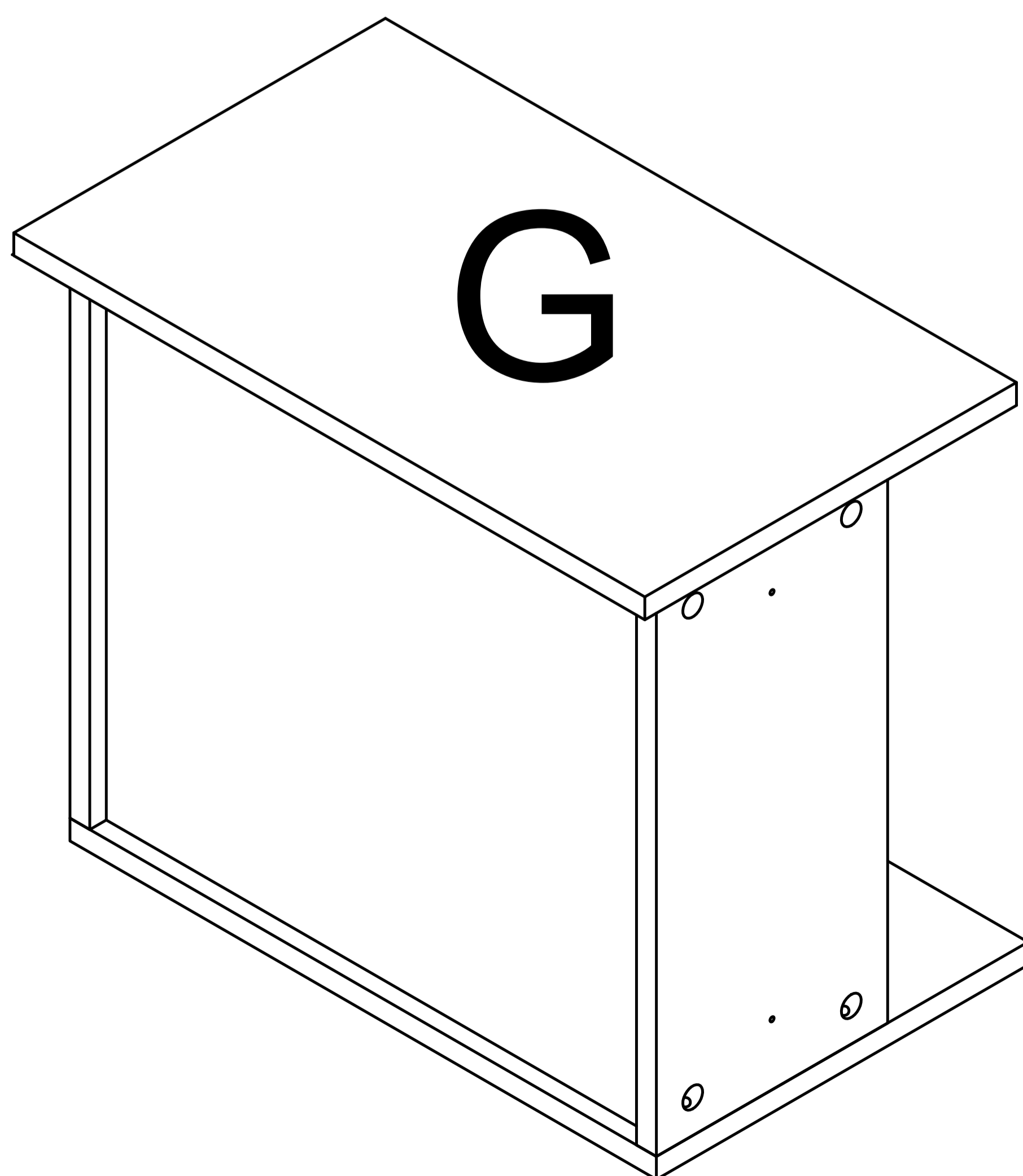

x 2

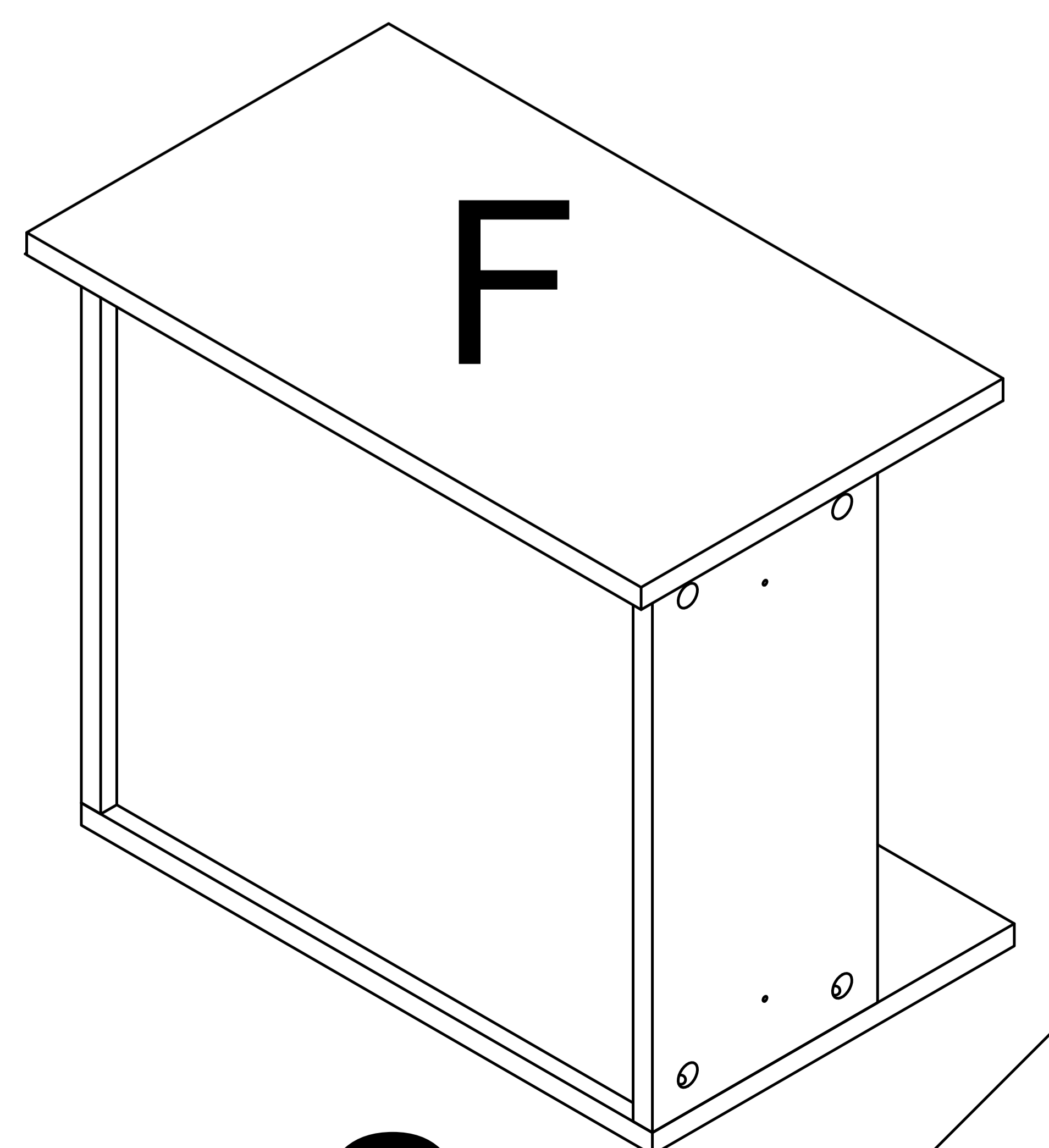

x 2

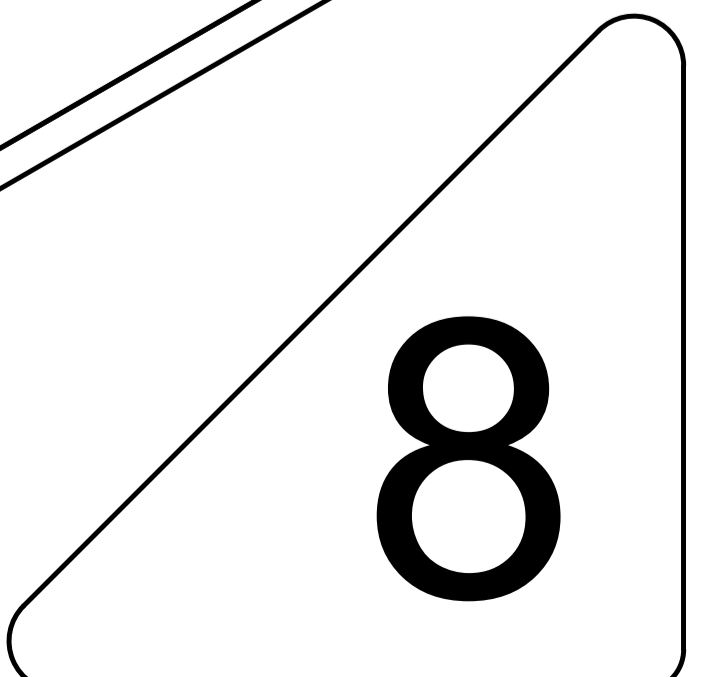

Drawer rail breakdown diagram

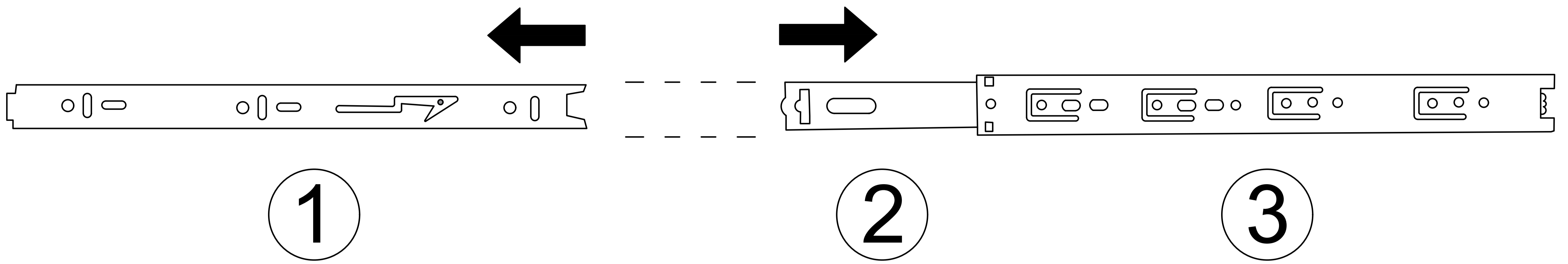

① Dismantle the schematic diagram

Step 1 : Pull the rails apart

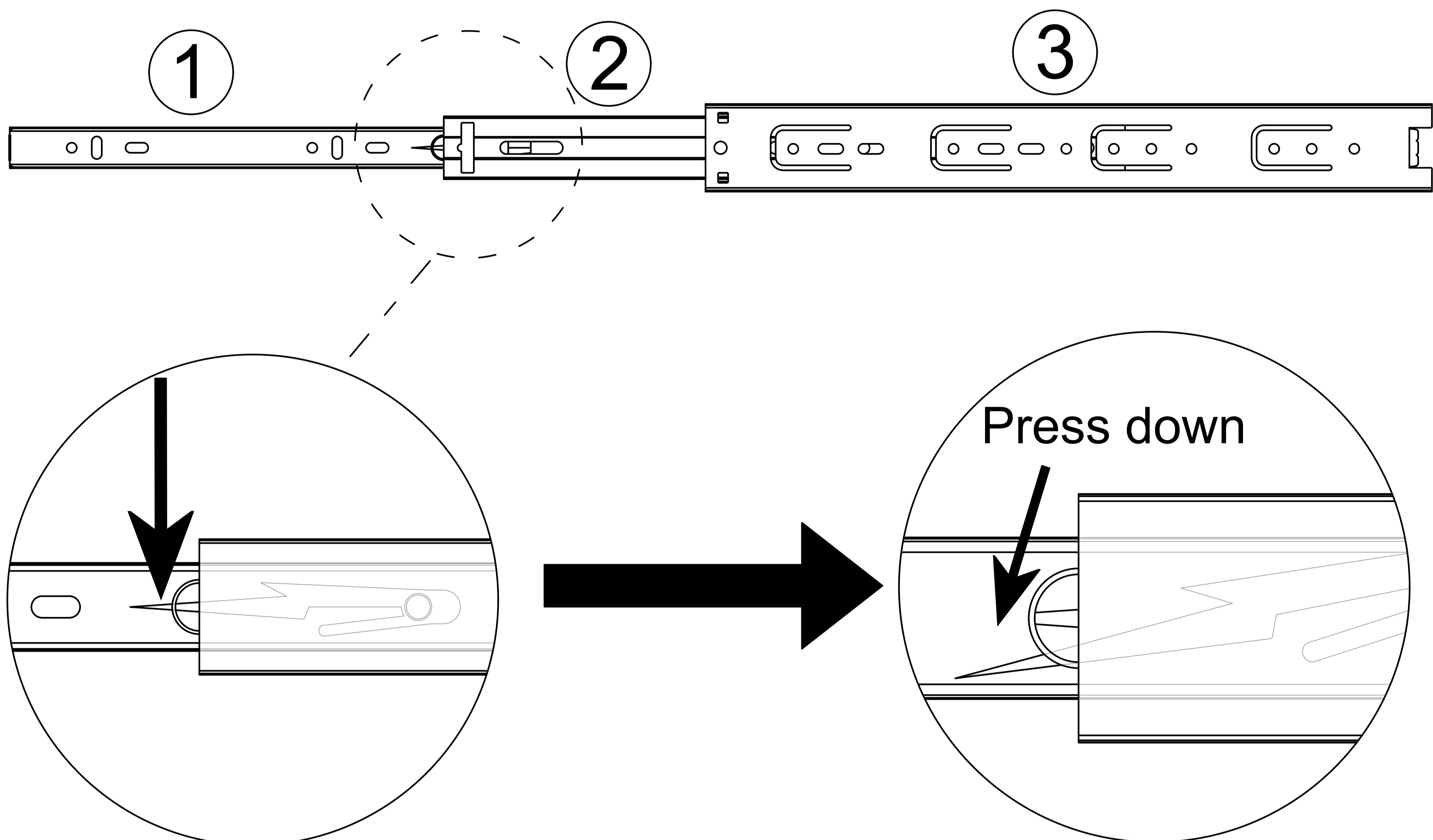

Step 2 : Press the nylon button and pull out ①.

Drawer rail decomposition completed schematic diagram

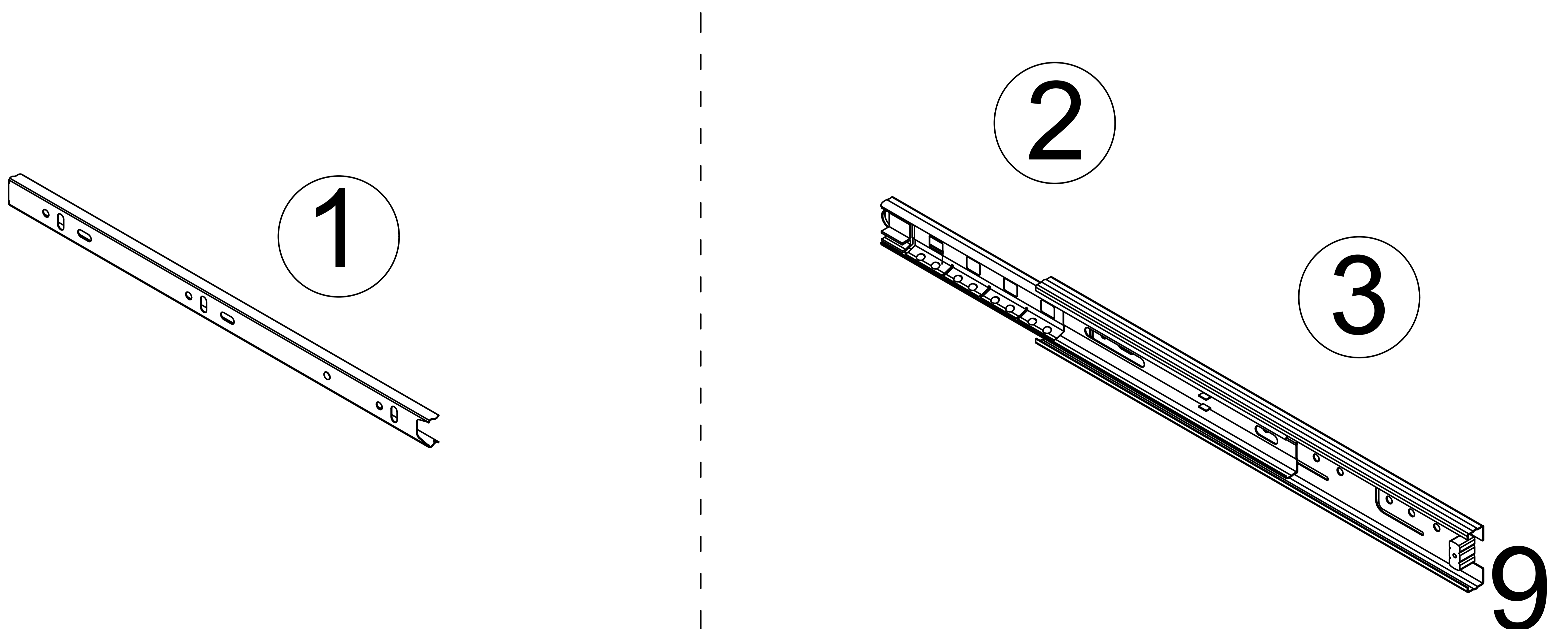

Step 8

4

x12

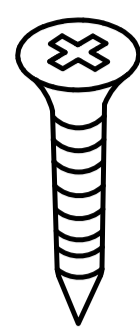

x24

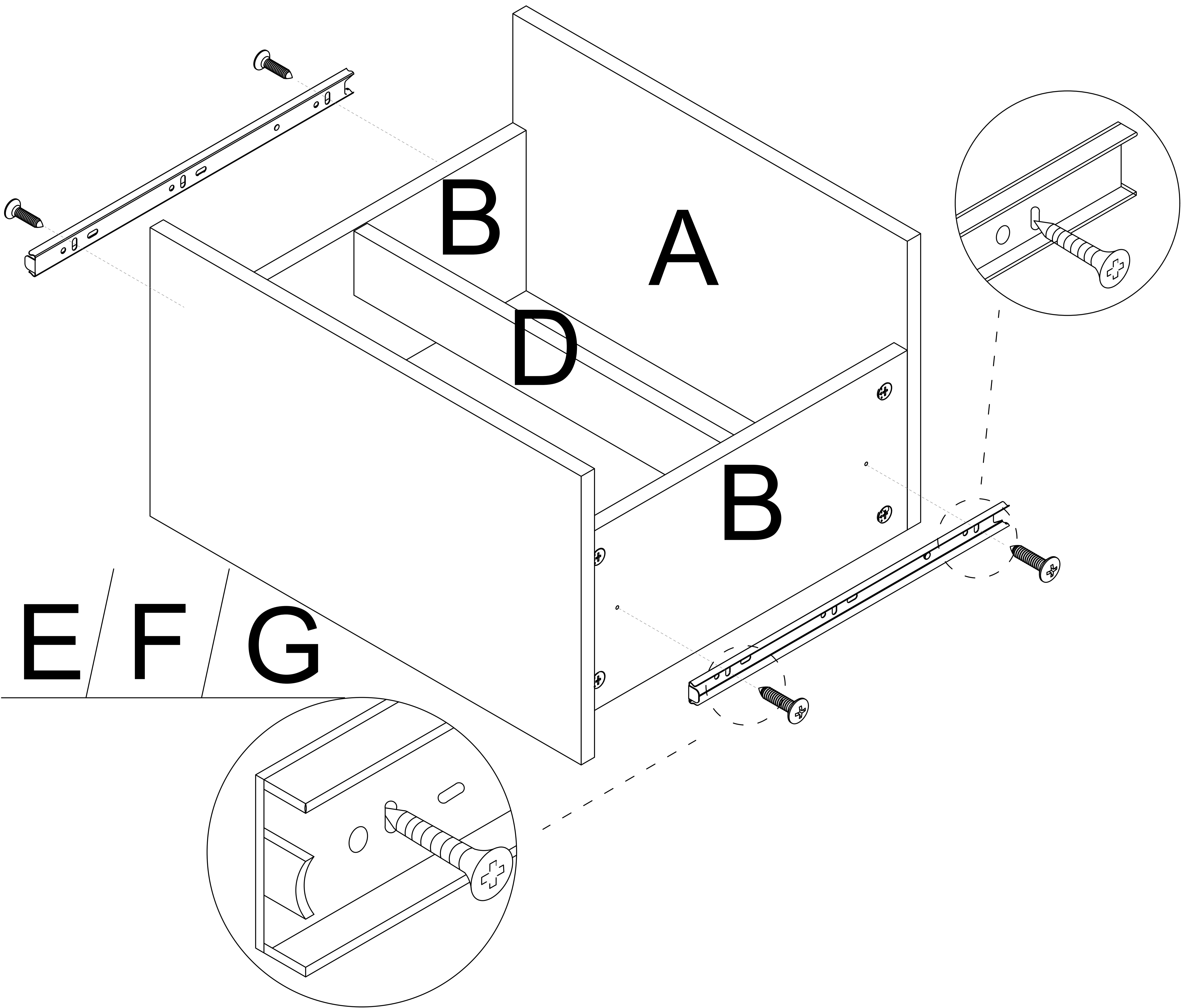
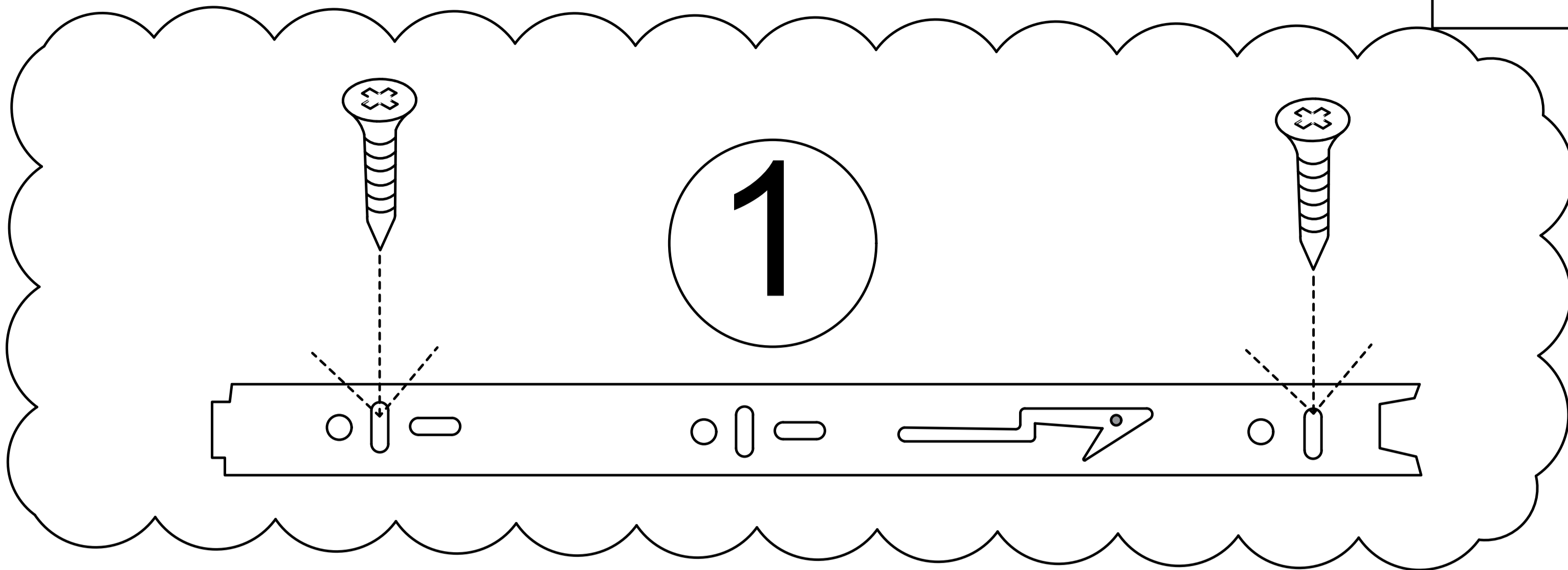

You can repeat the previous steps to obtain 6 identical drawers.

Step 9

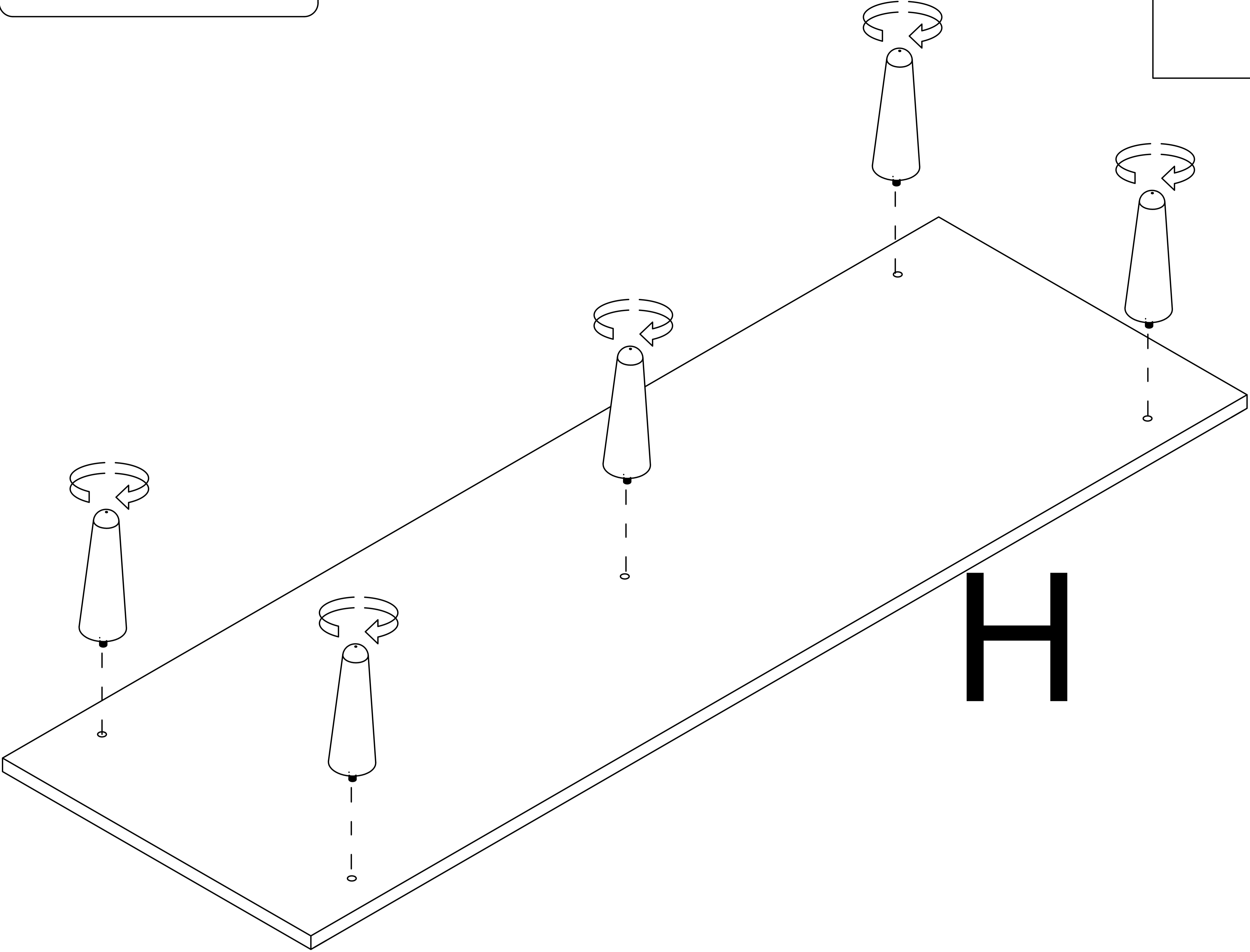
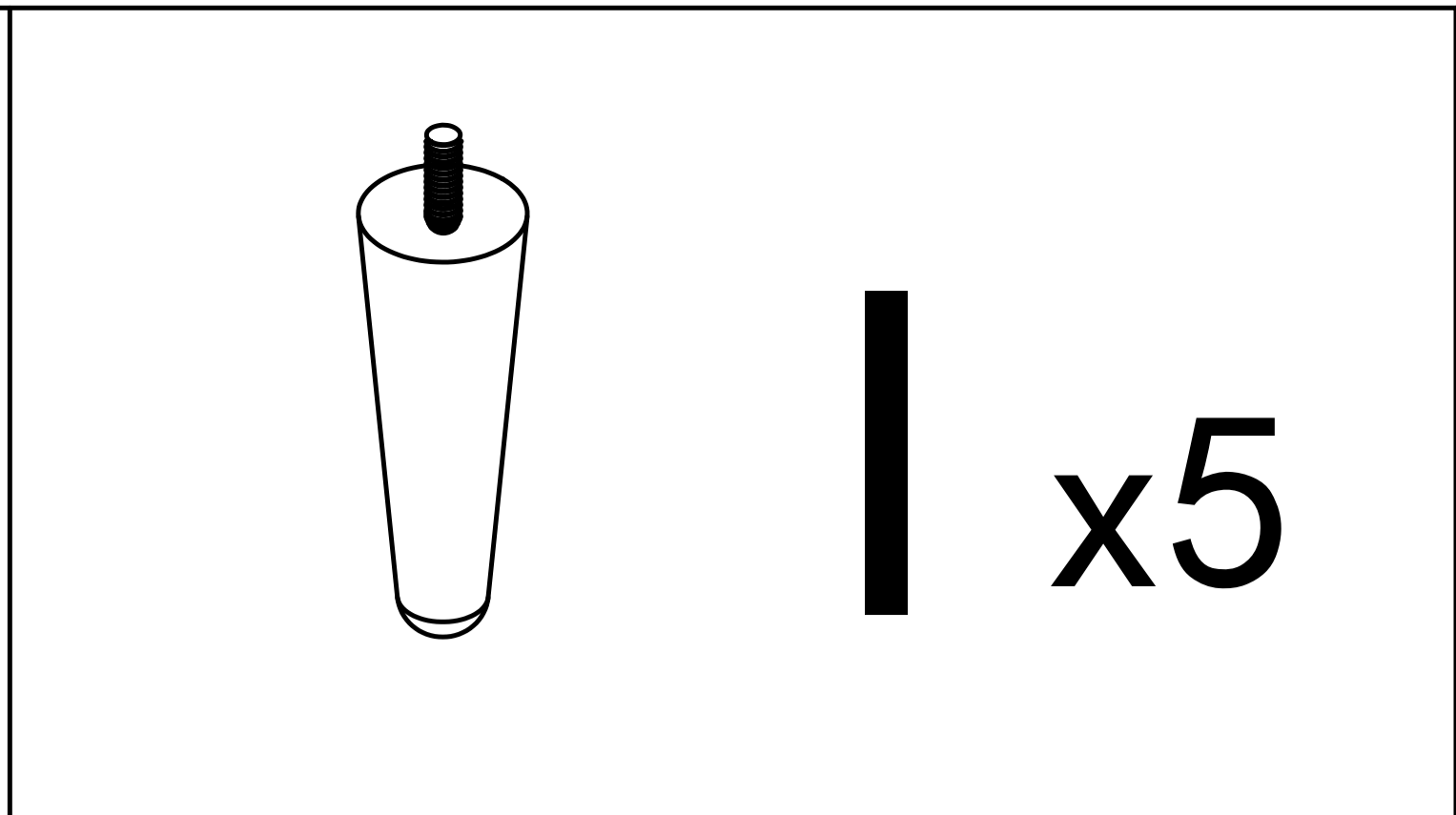

Step 10

Tear off release paper and stick the black foot pad on the board

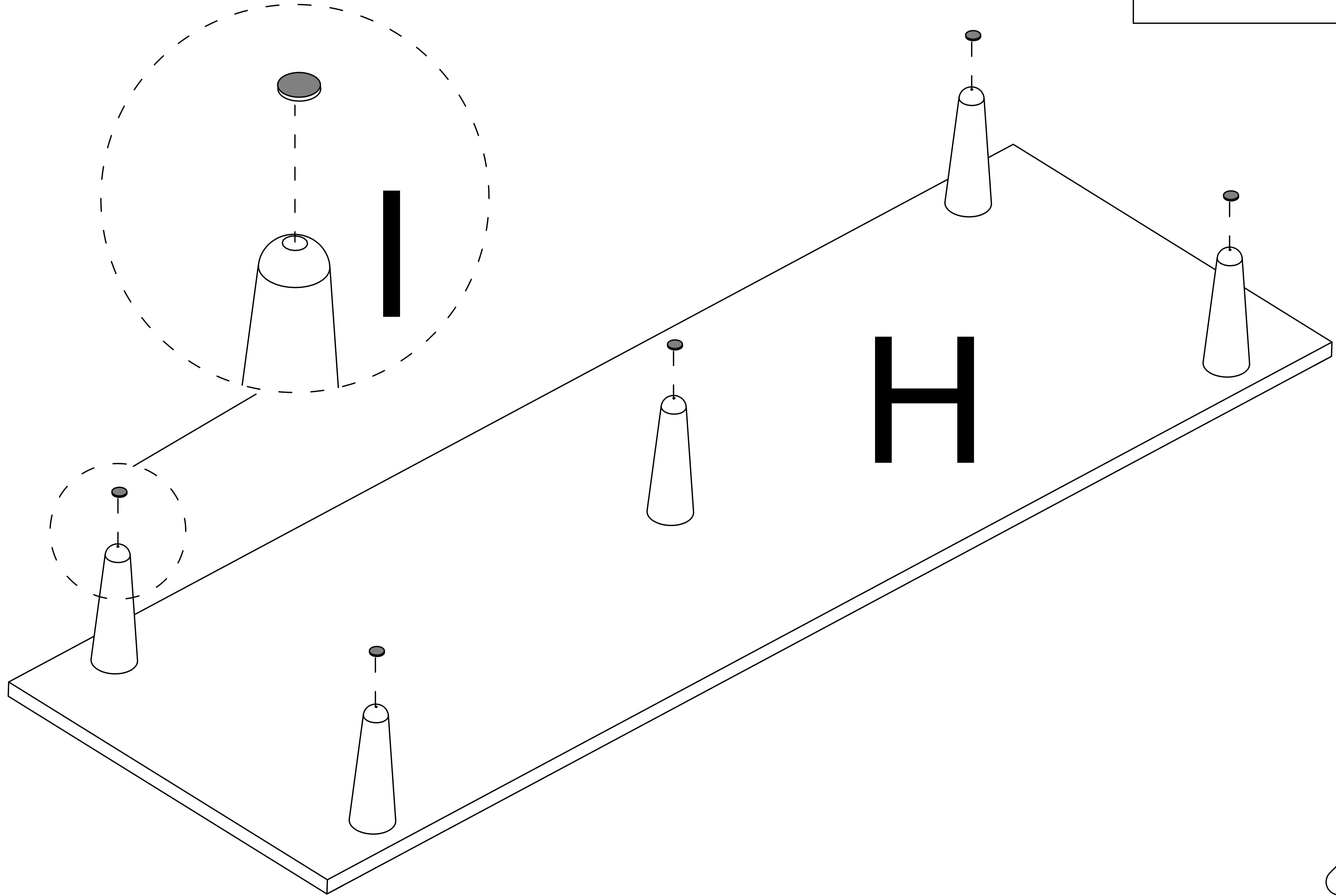
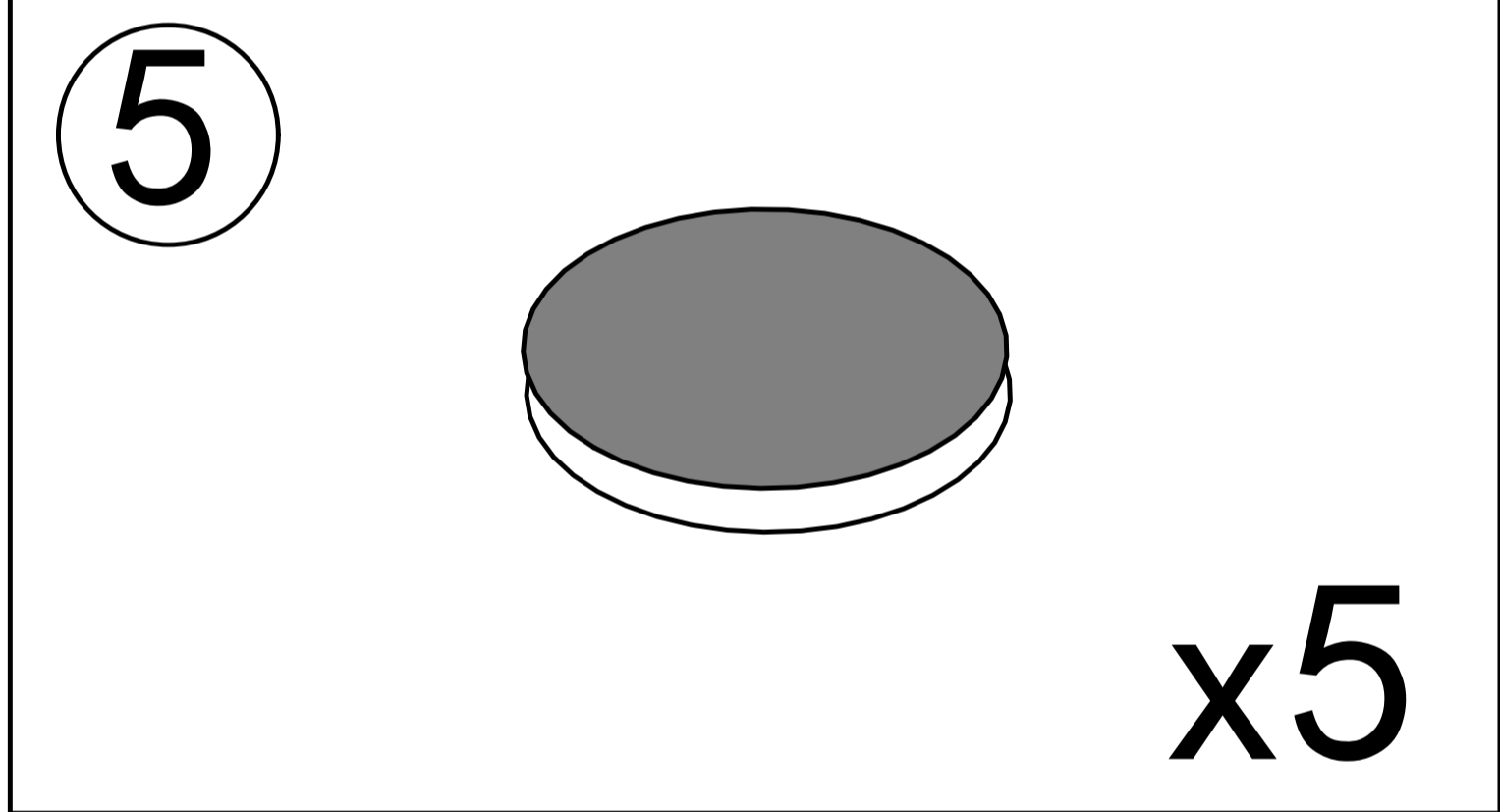

Step 11

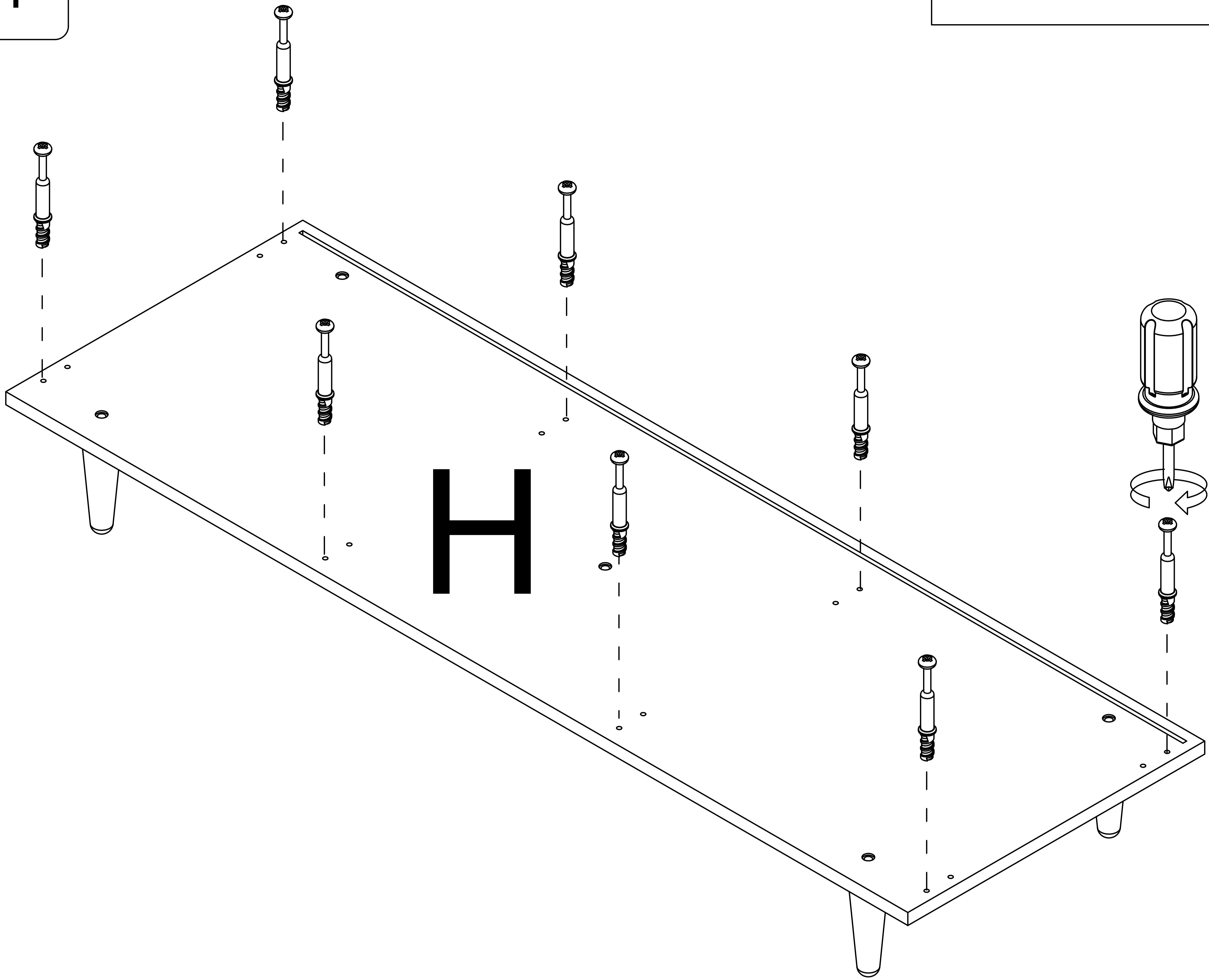
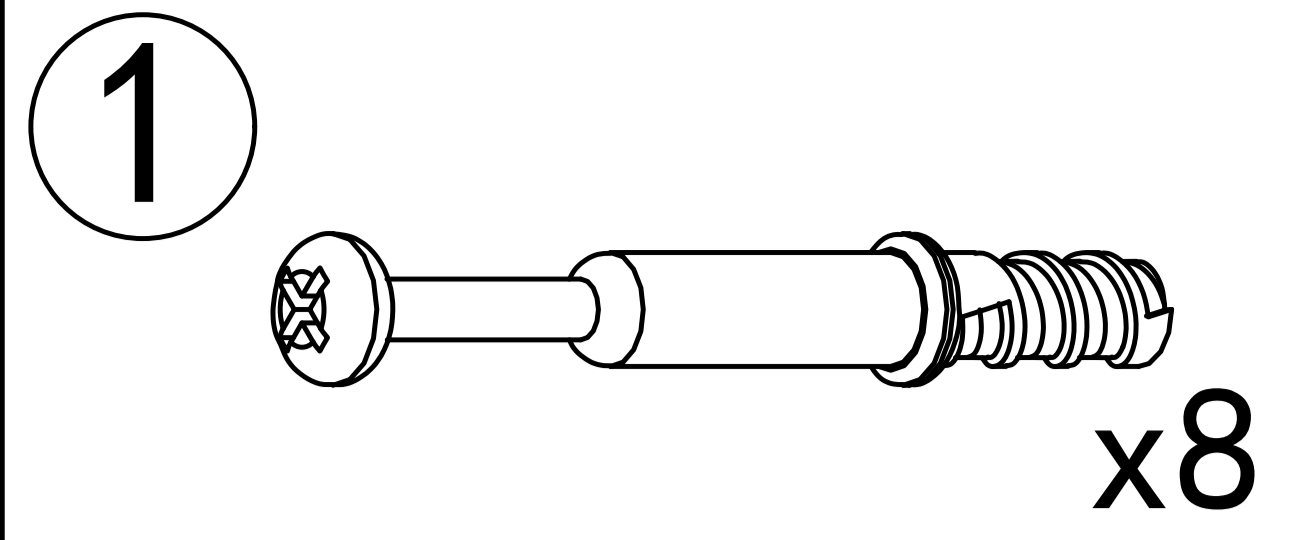

Step 12

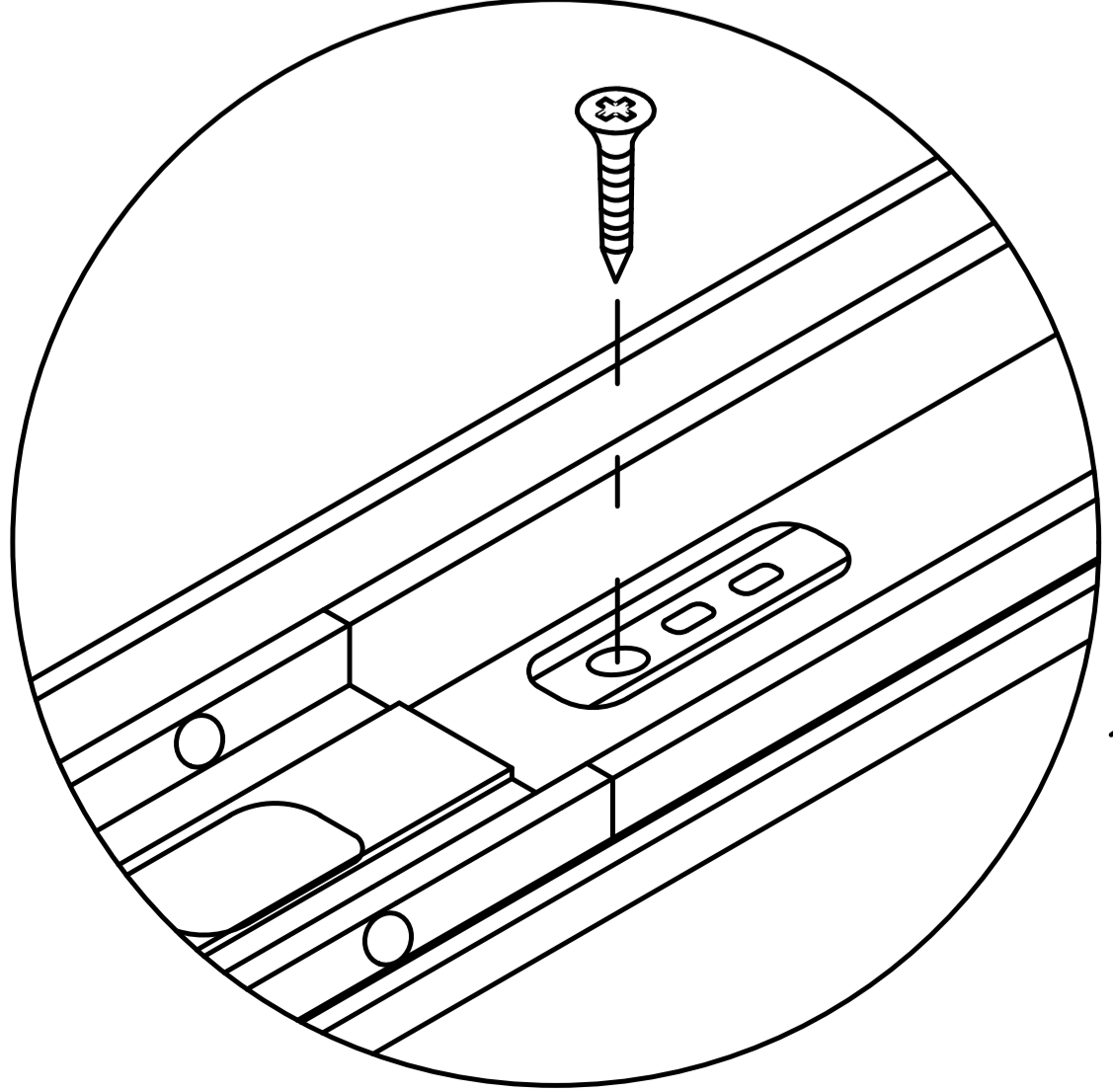
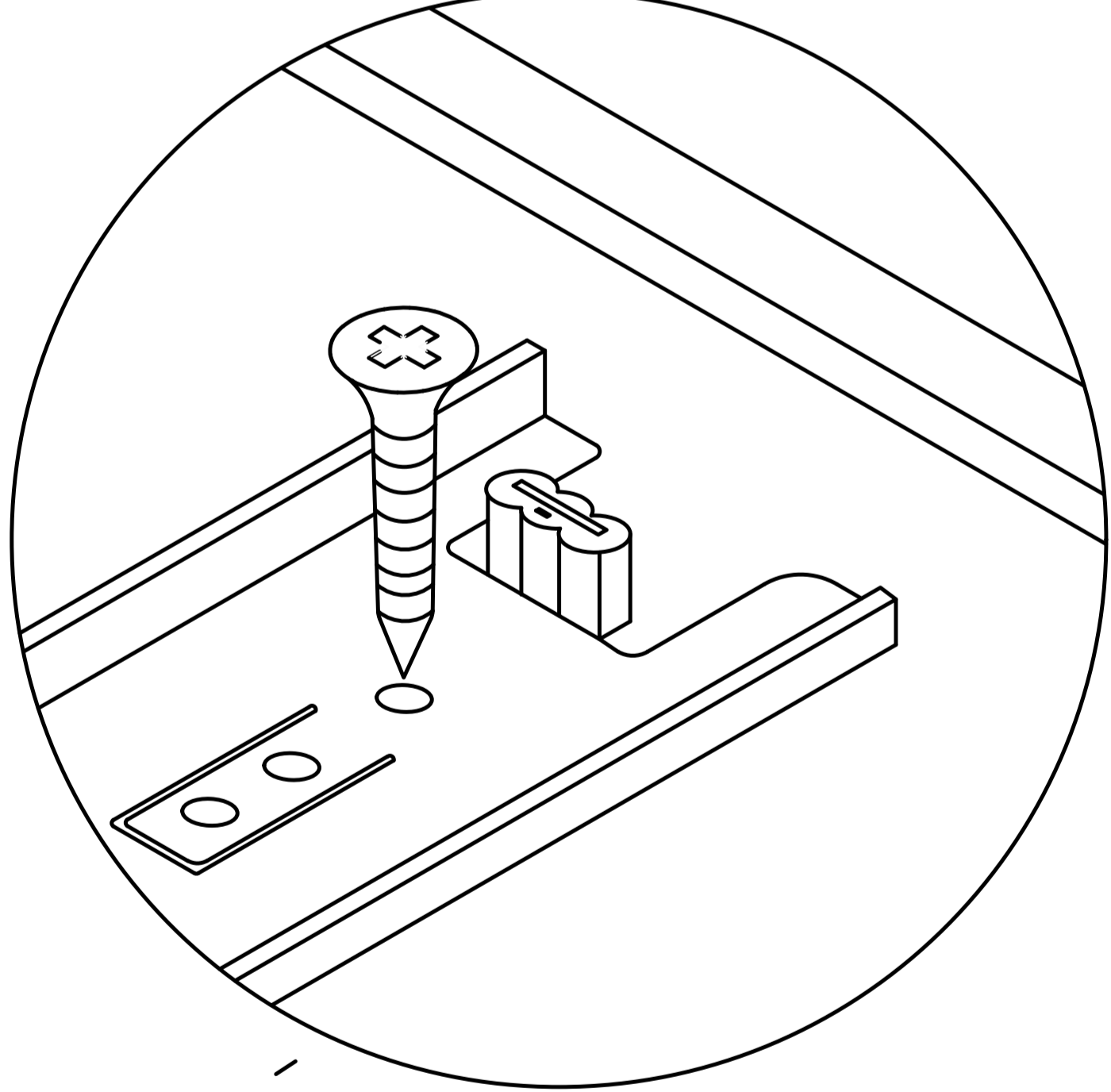
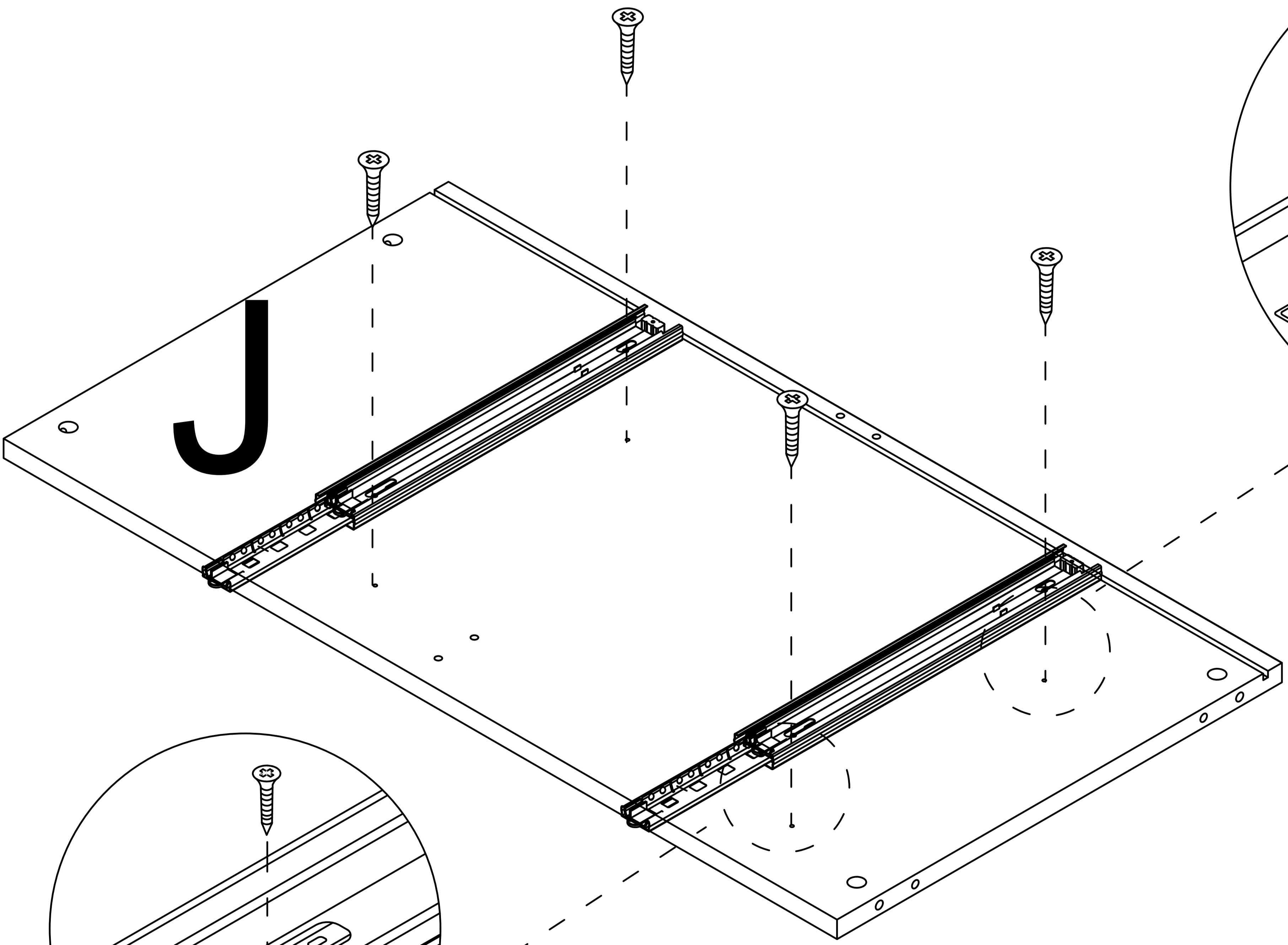
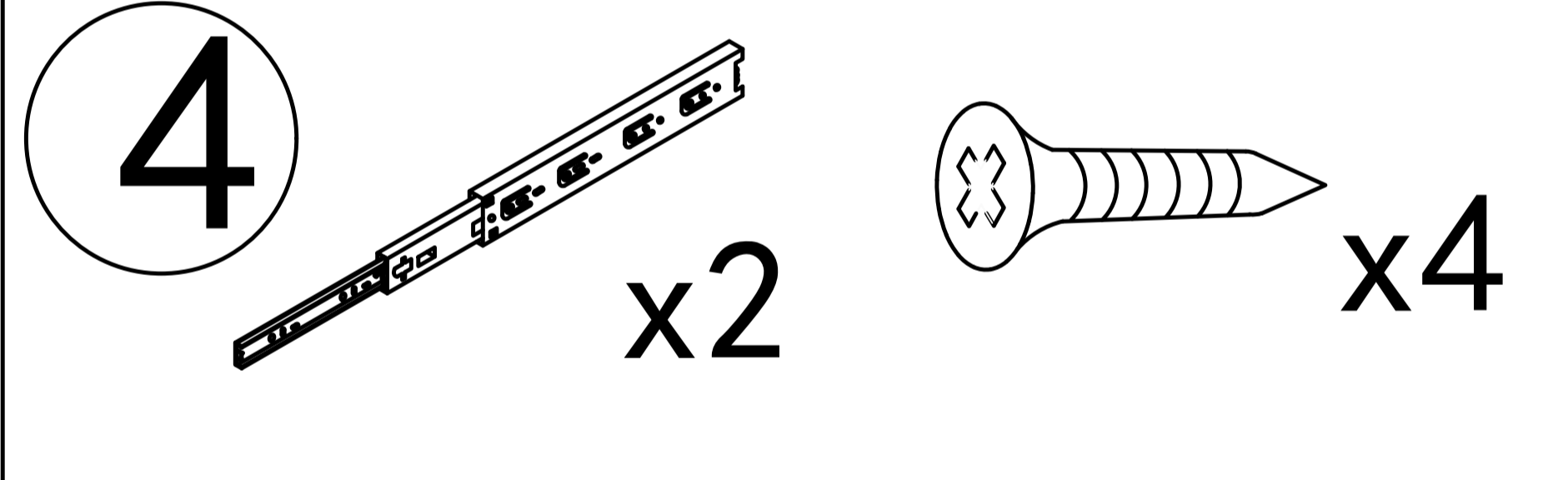
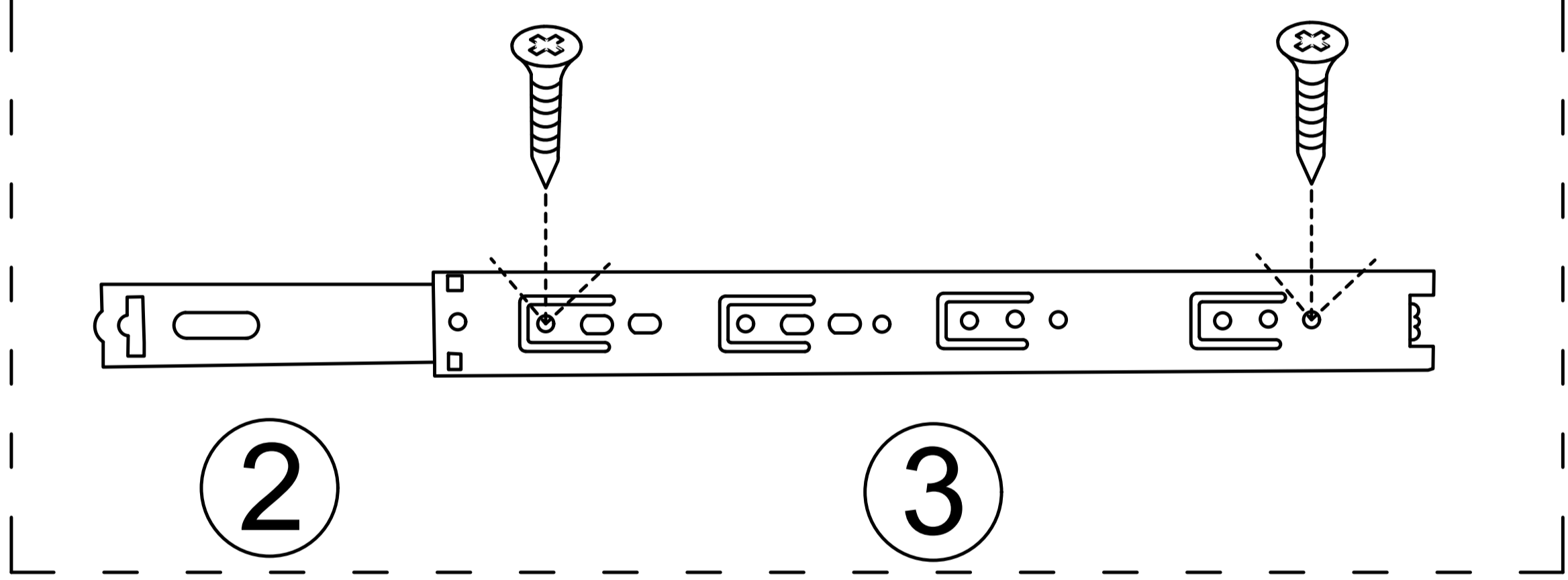

Step 13

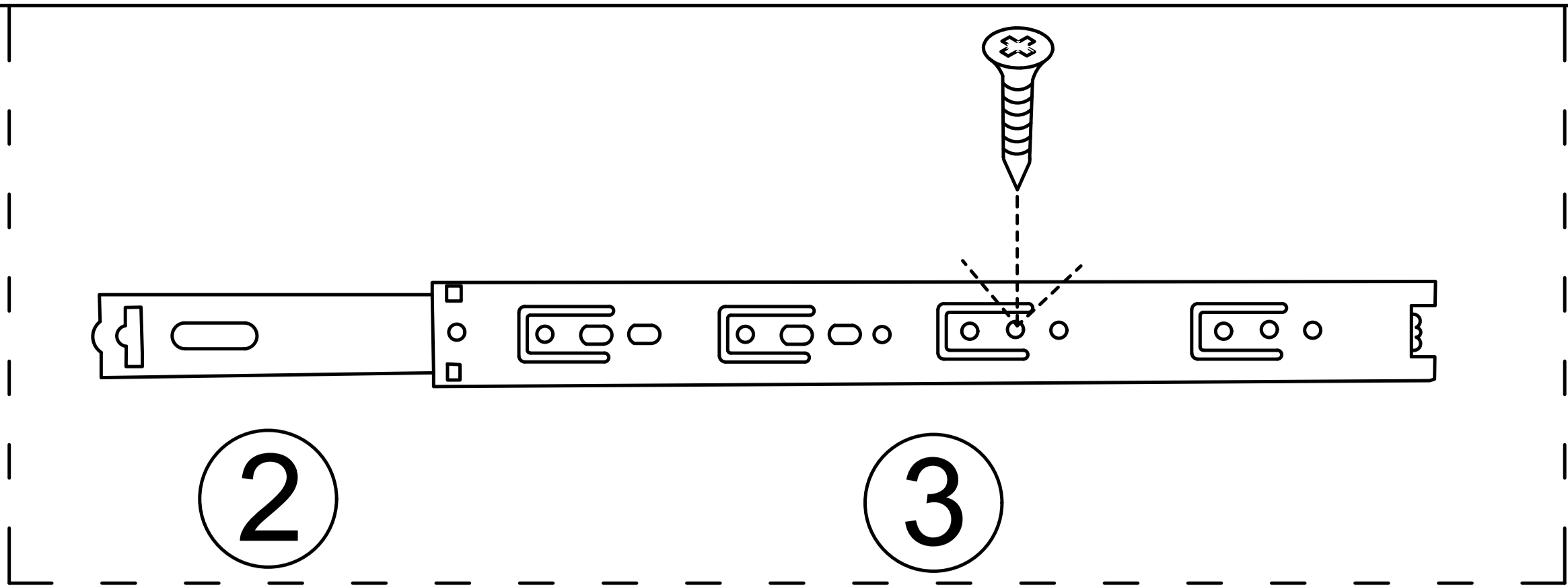

4

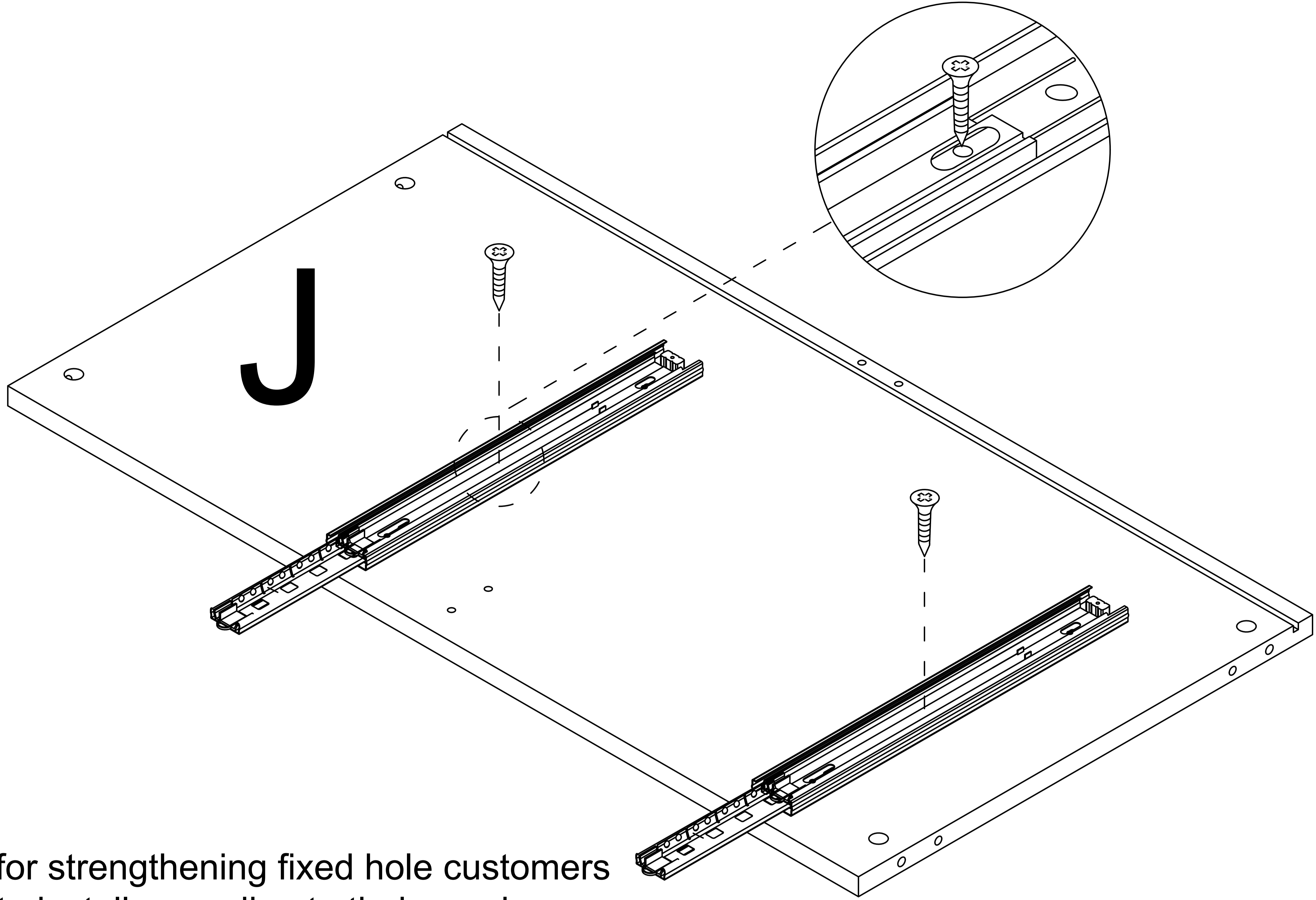
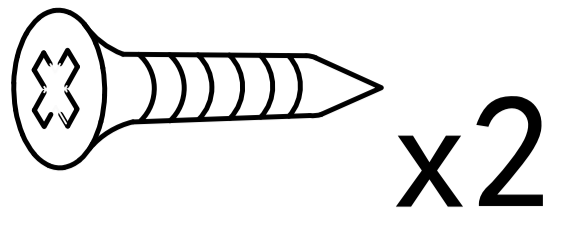

This hole is for strengthening fixed hole customers can choose to install according to their needs.

Step 14

1

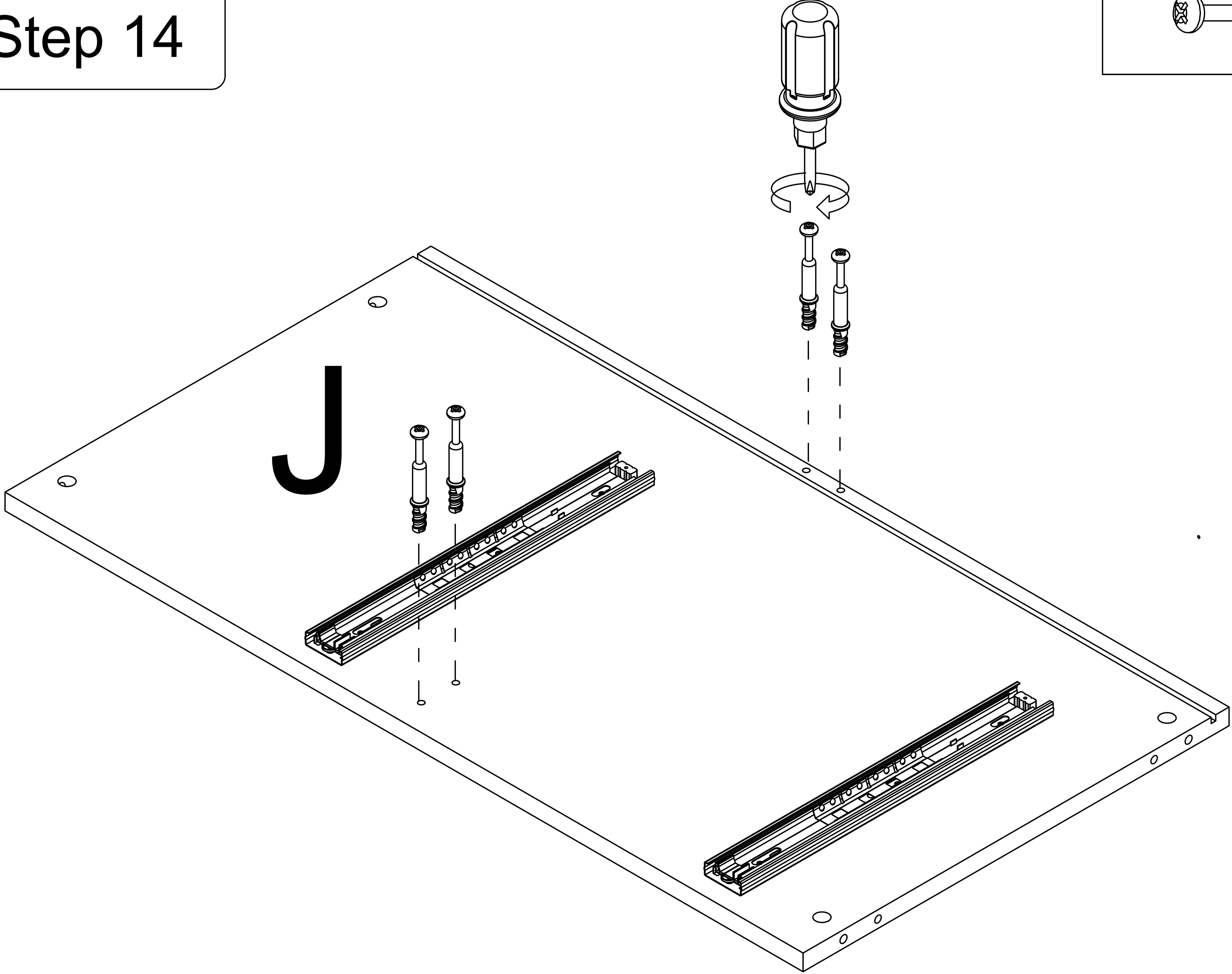
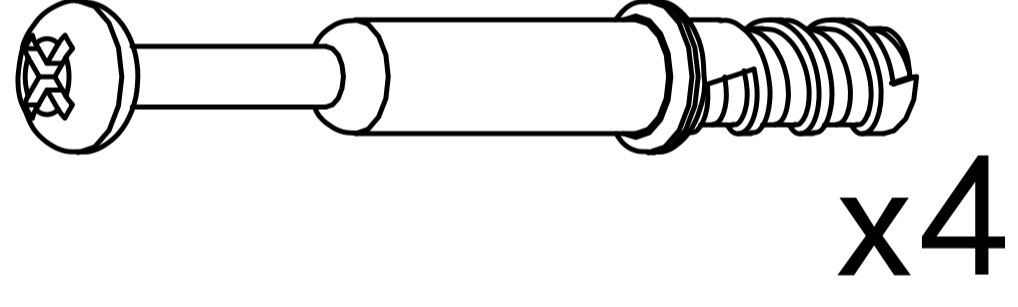

Step 15

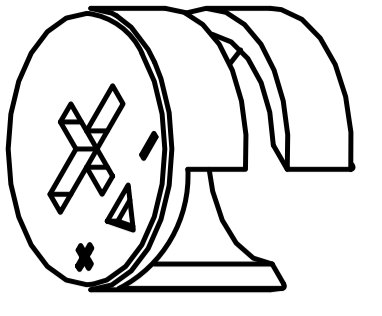
2  x2

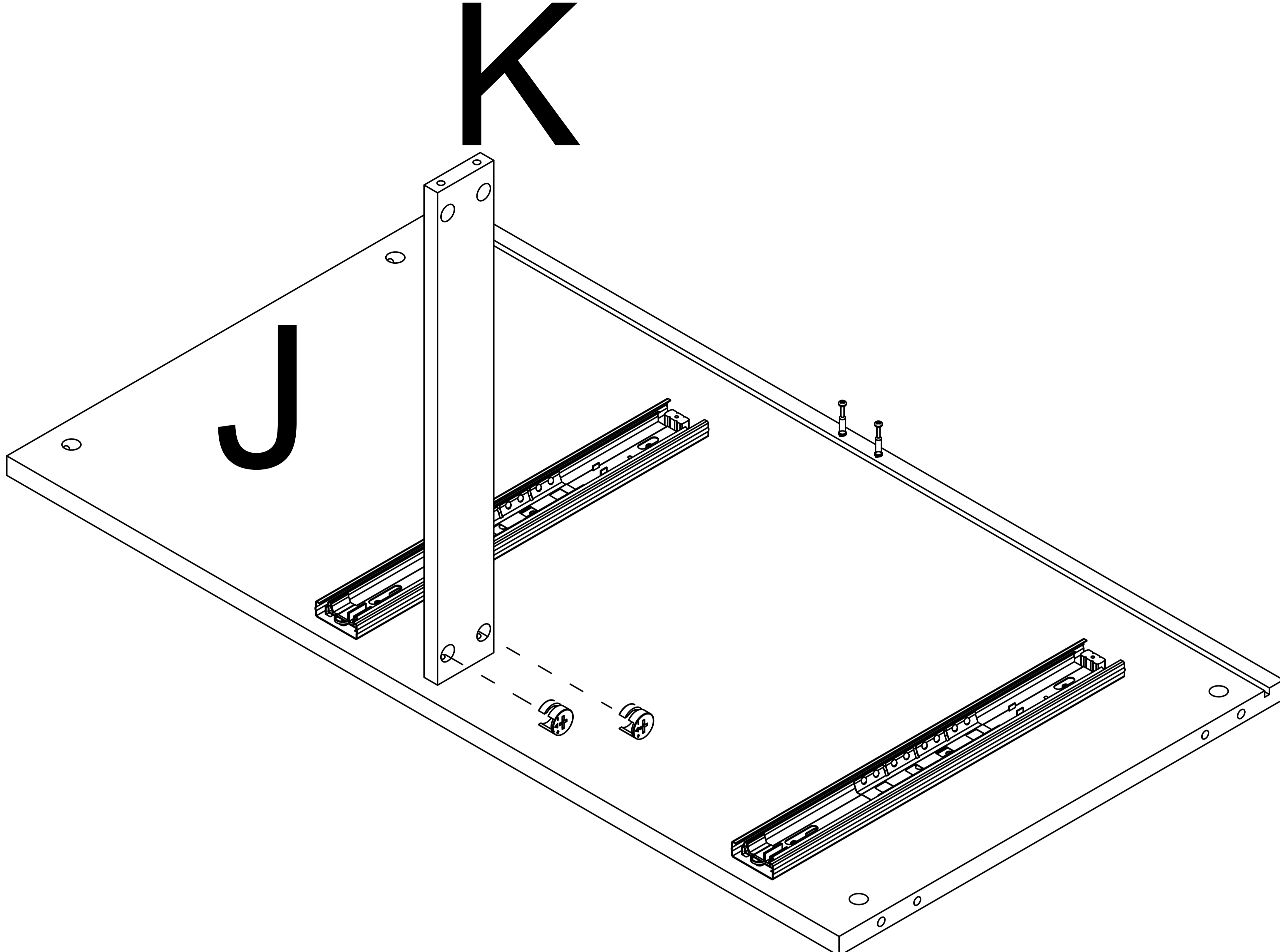

Step 16

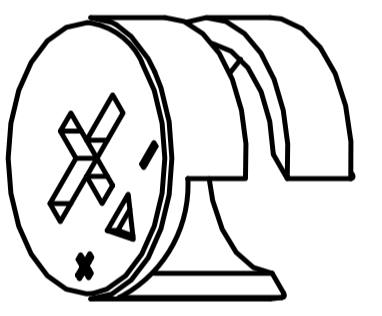
2  x2

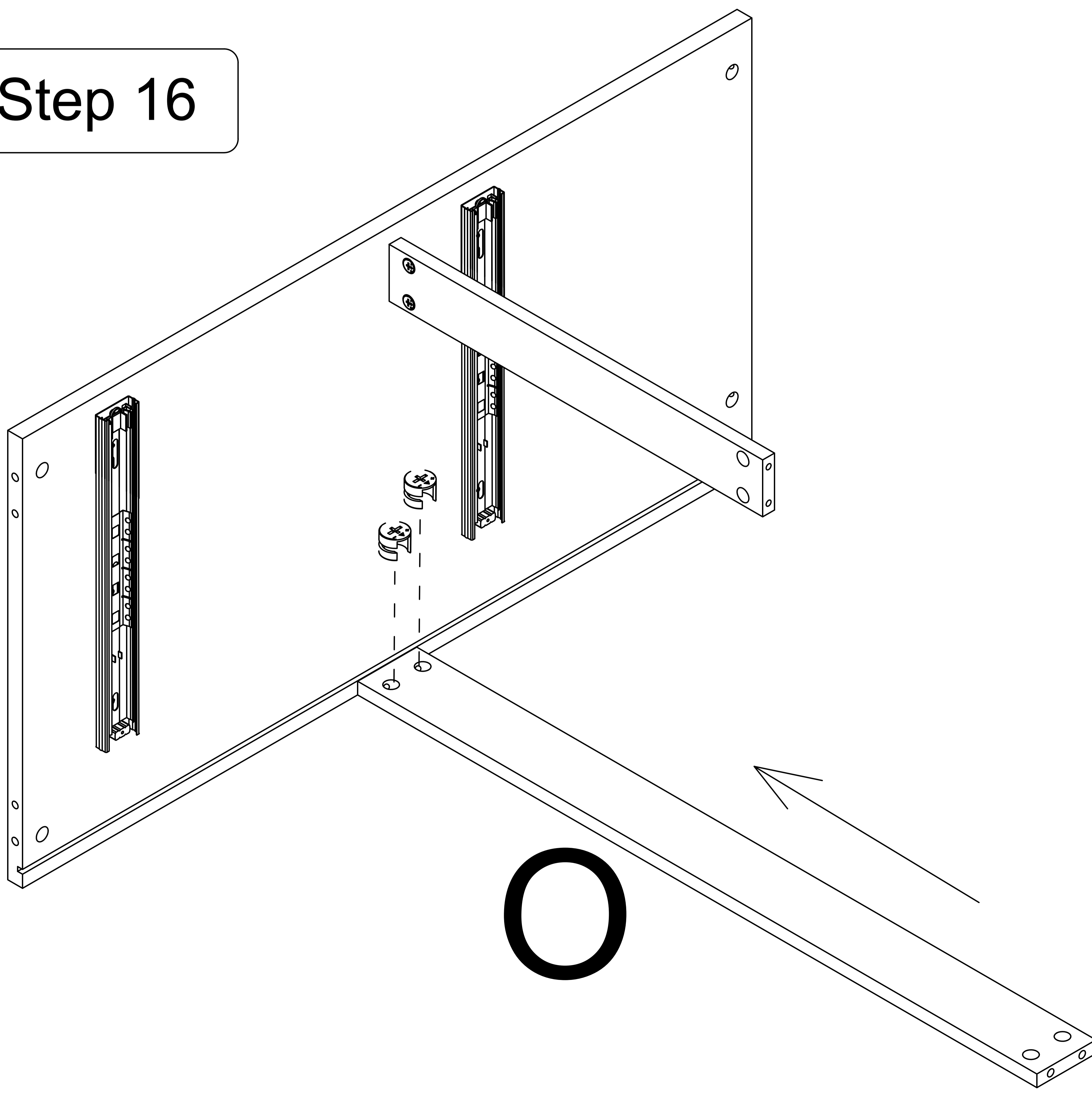

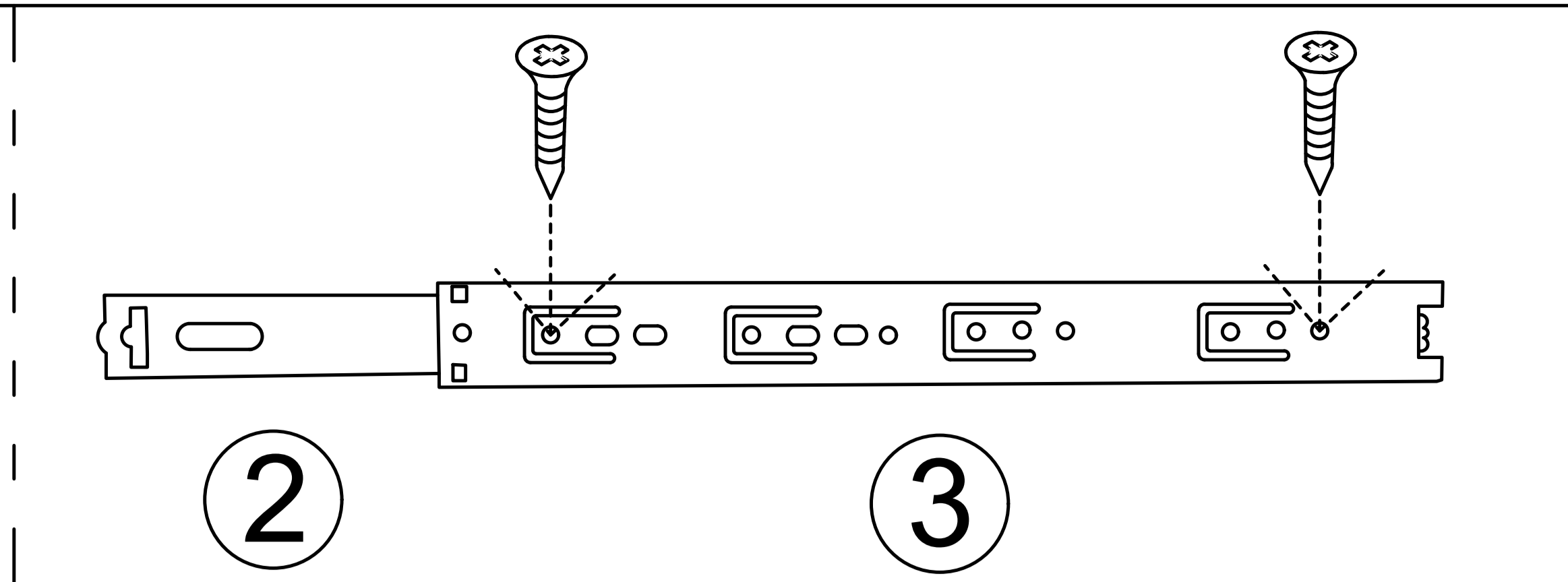

4

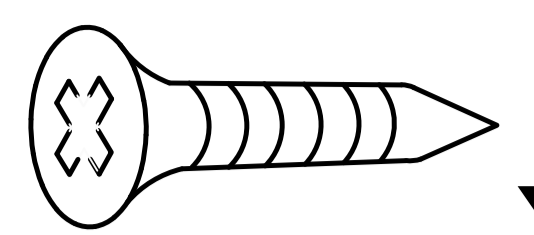
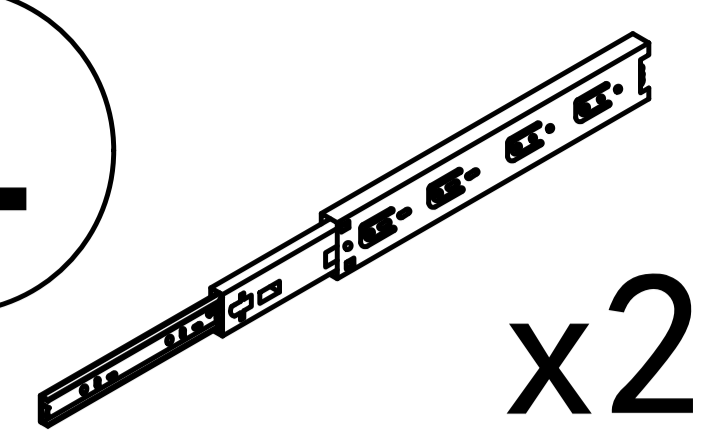

x4

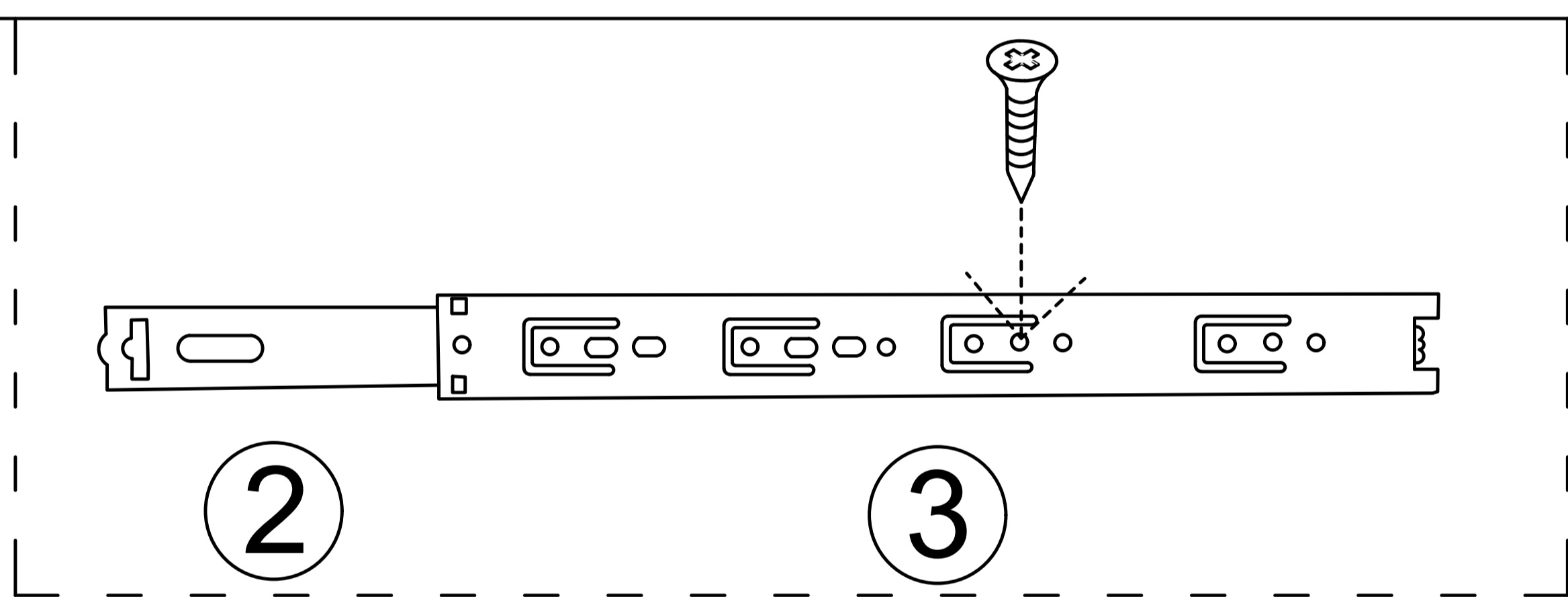
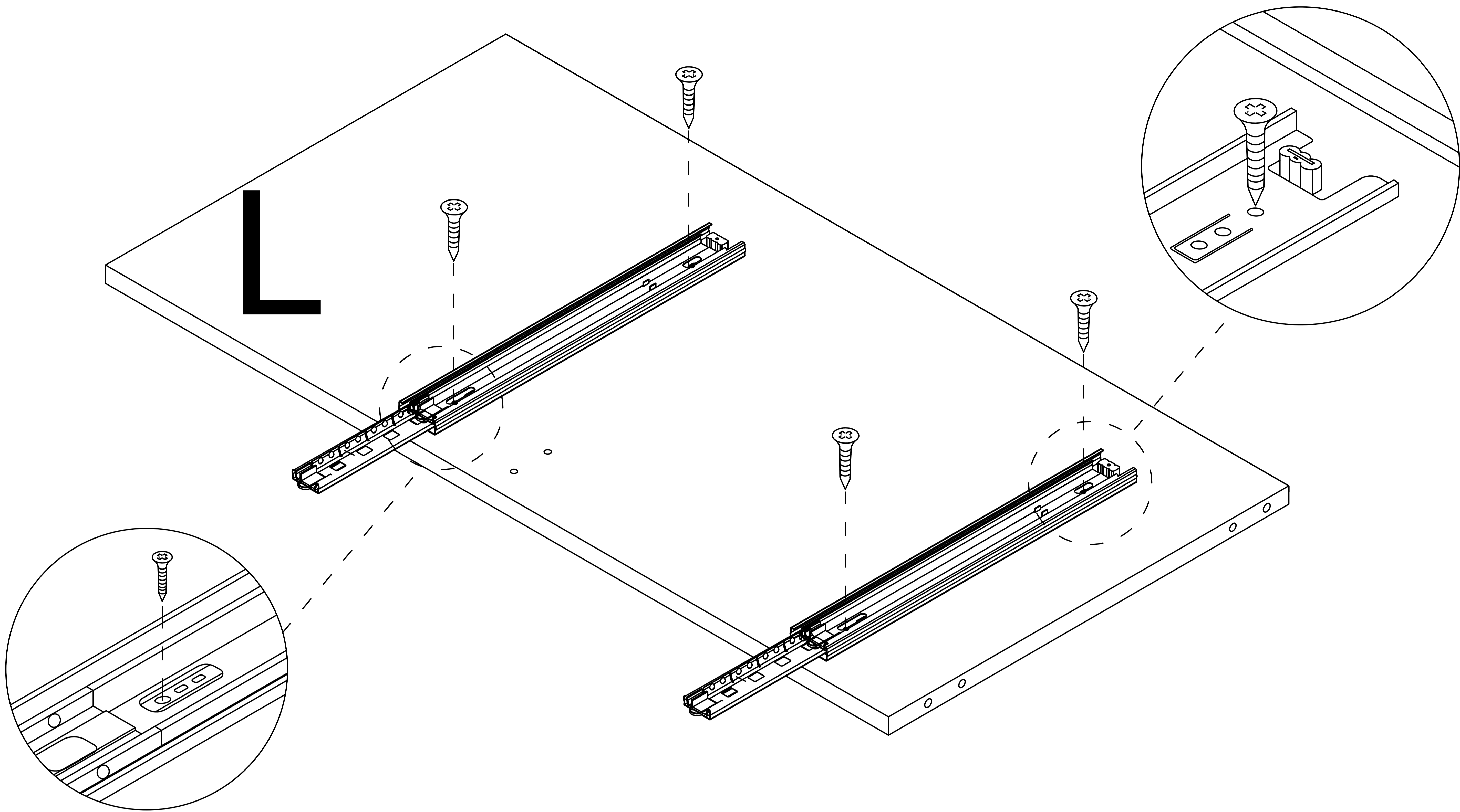

4

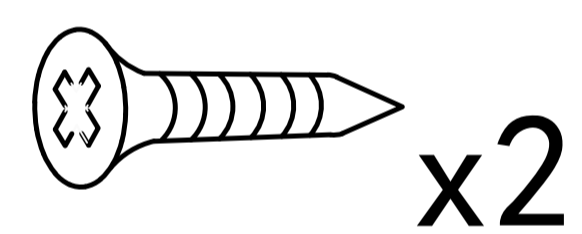

x2

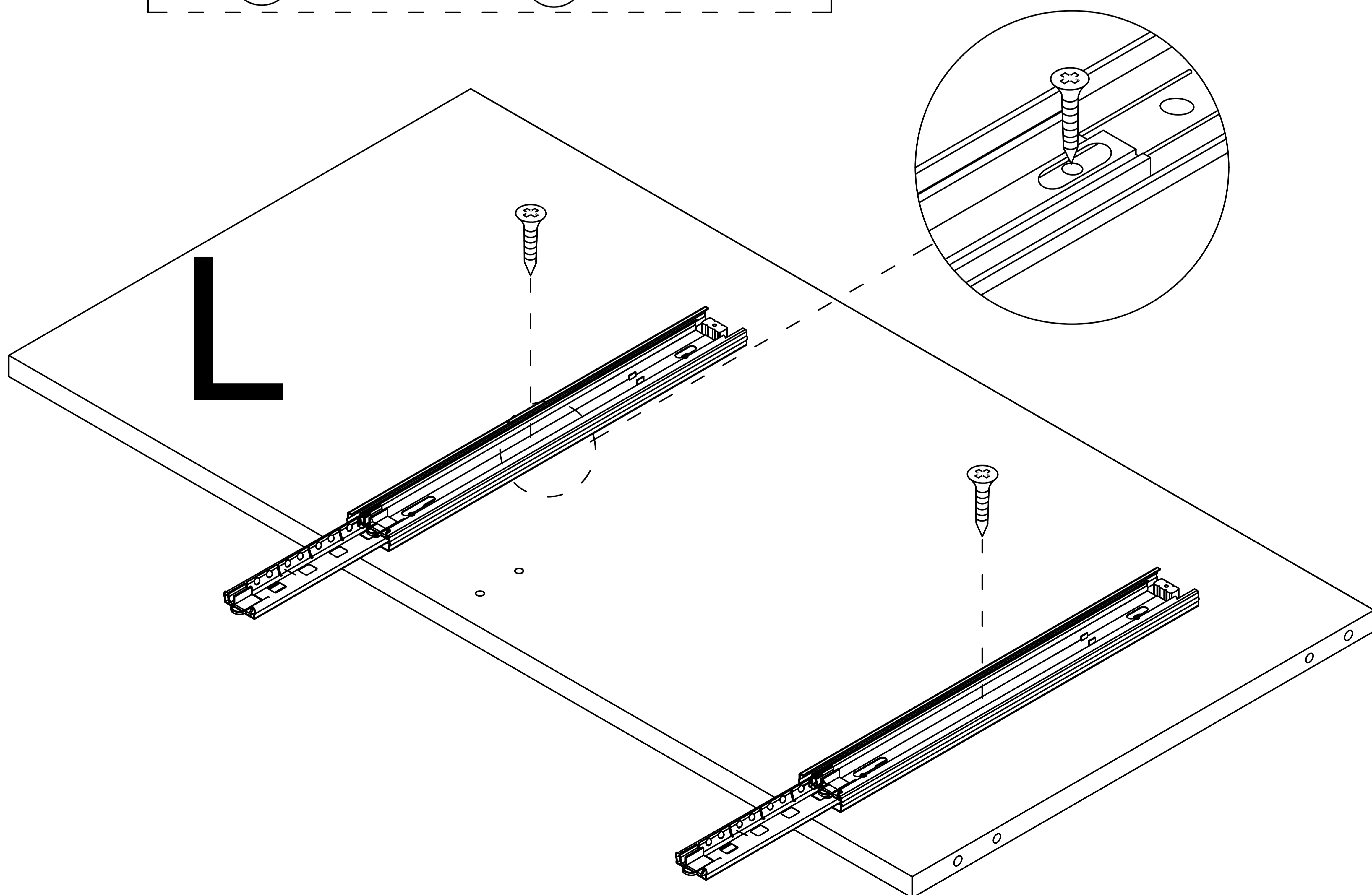

Step 17

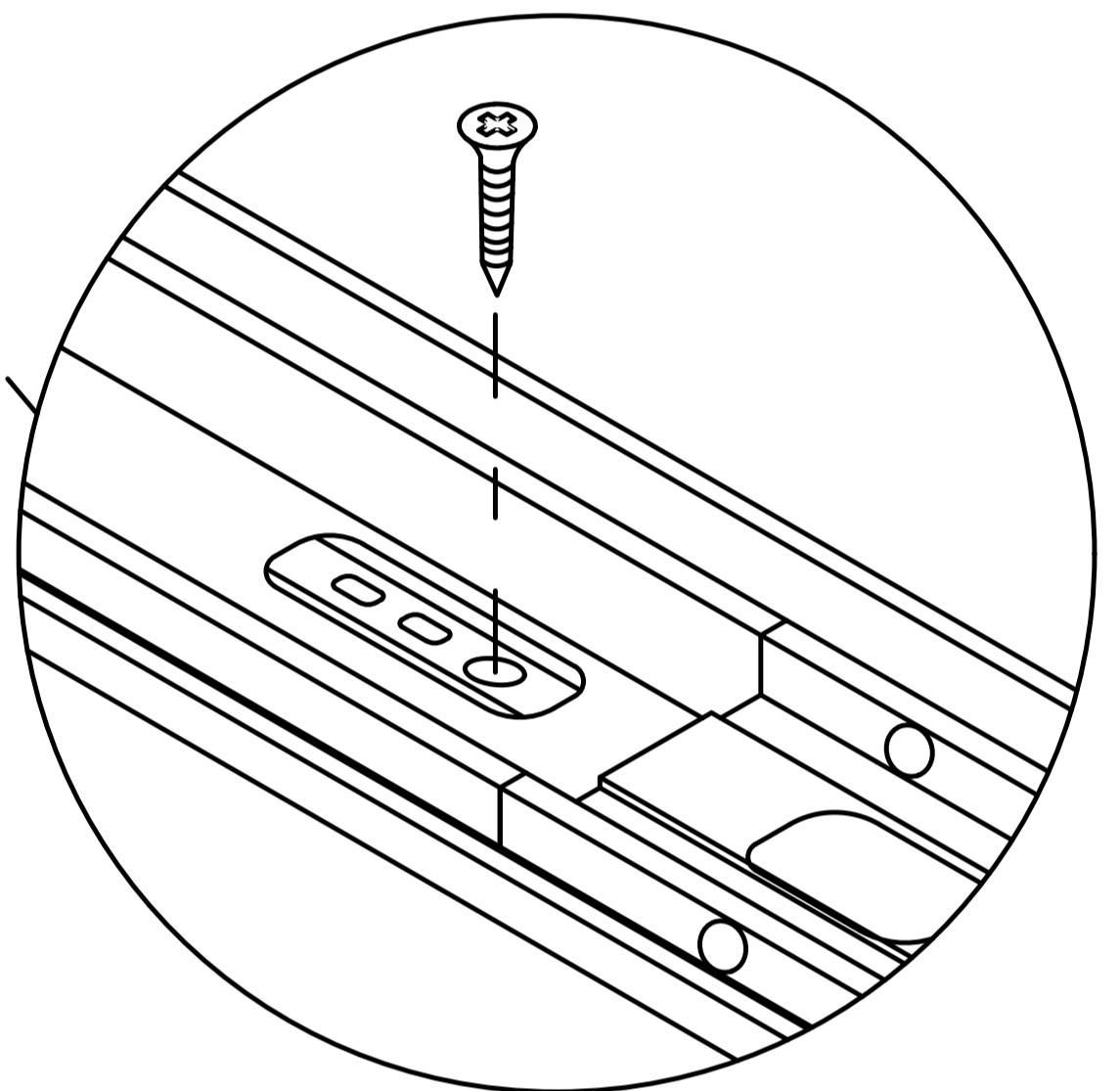
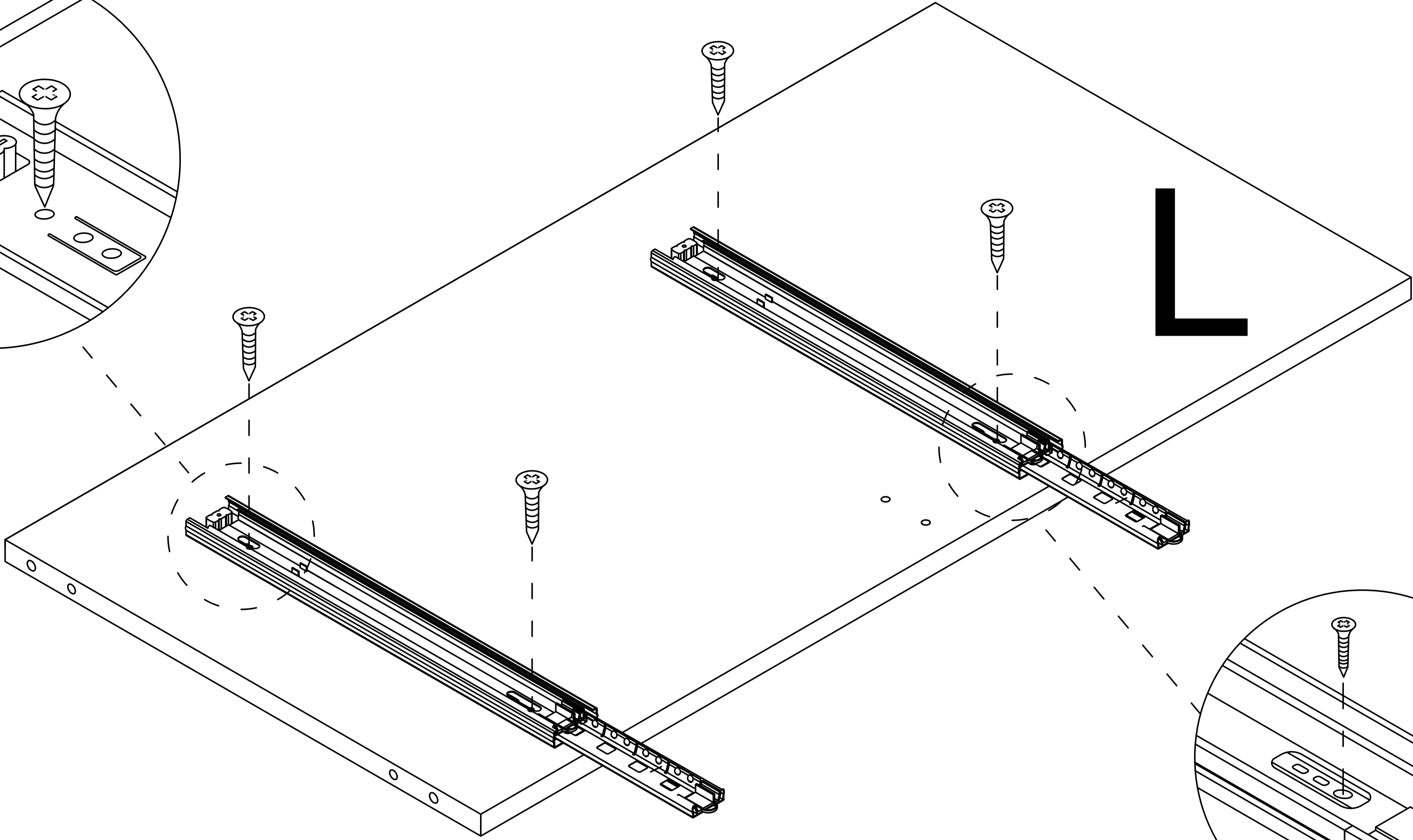
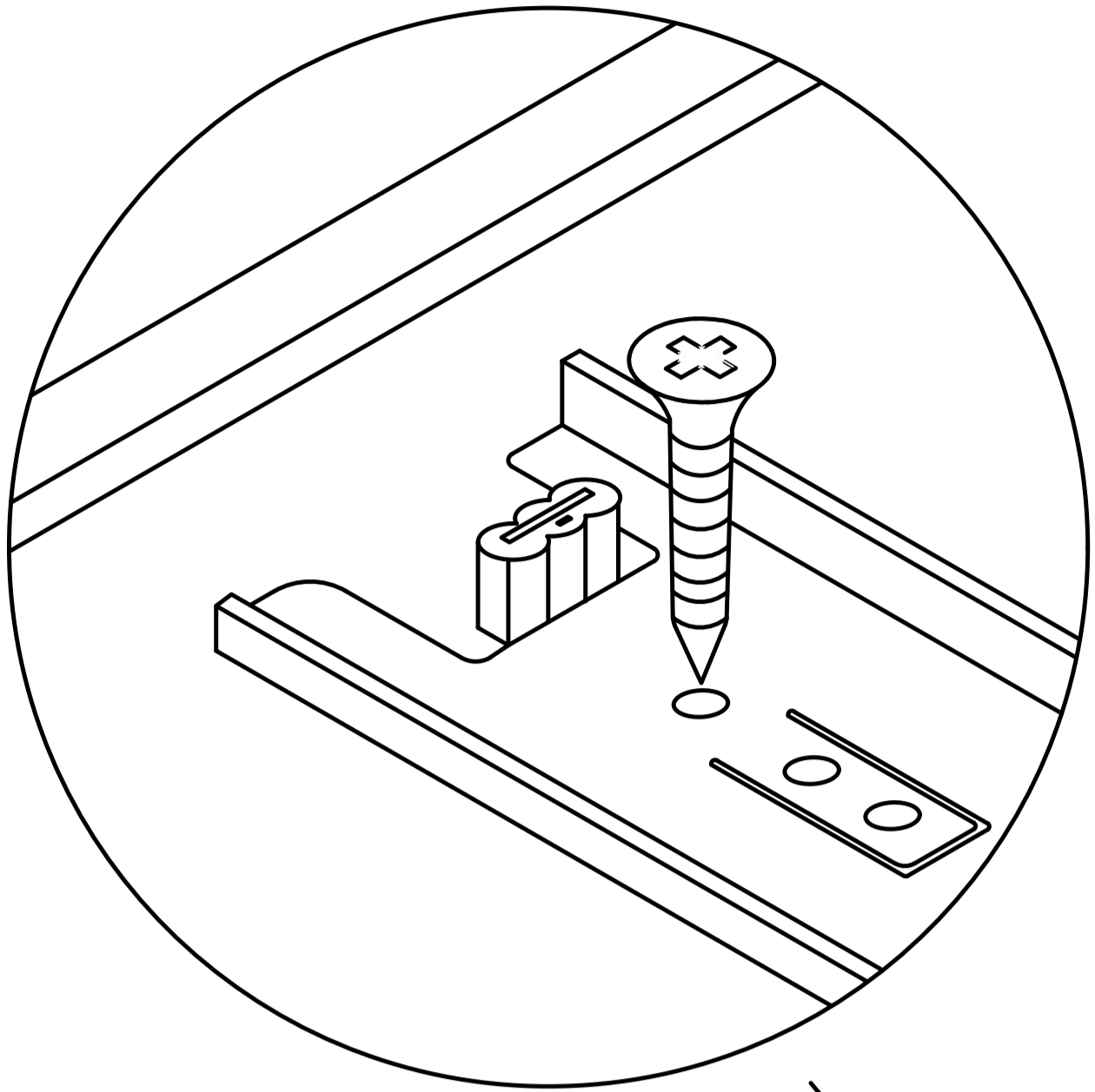
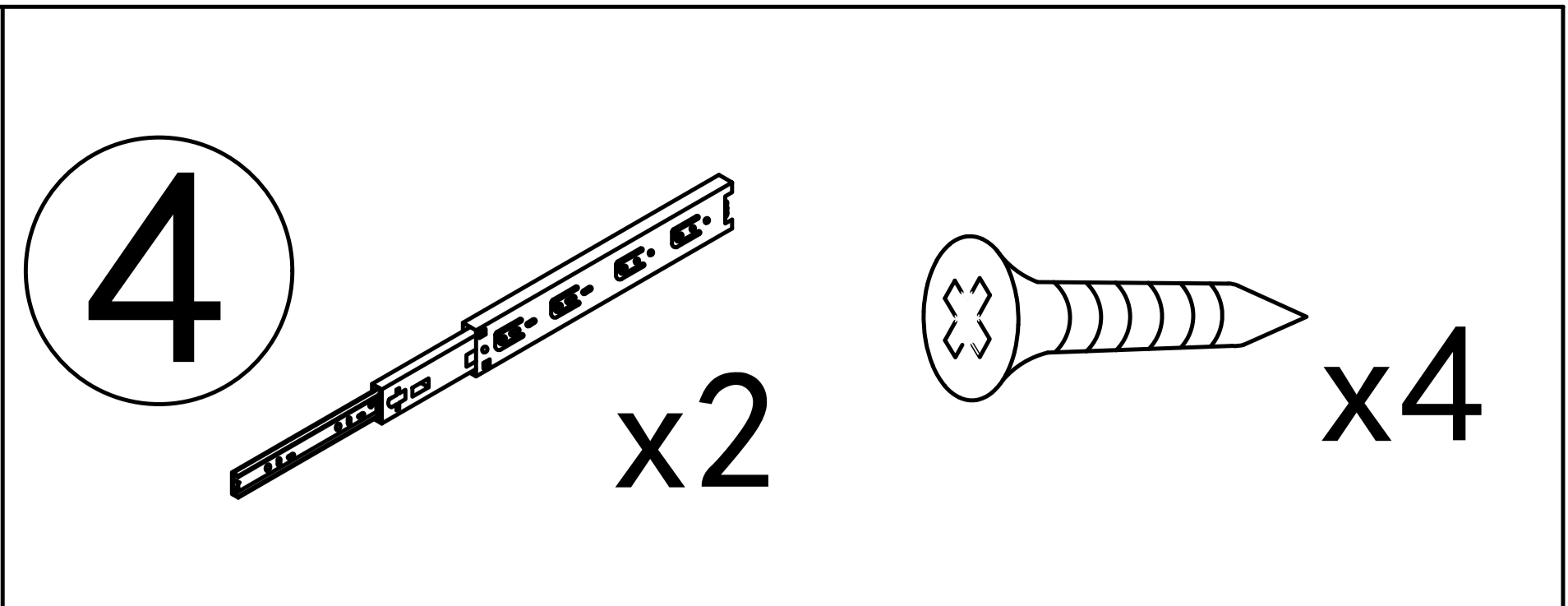
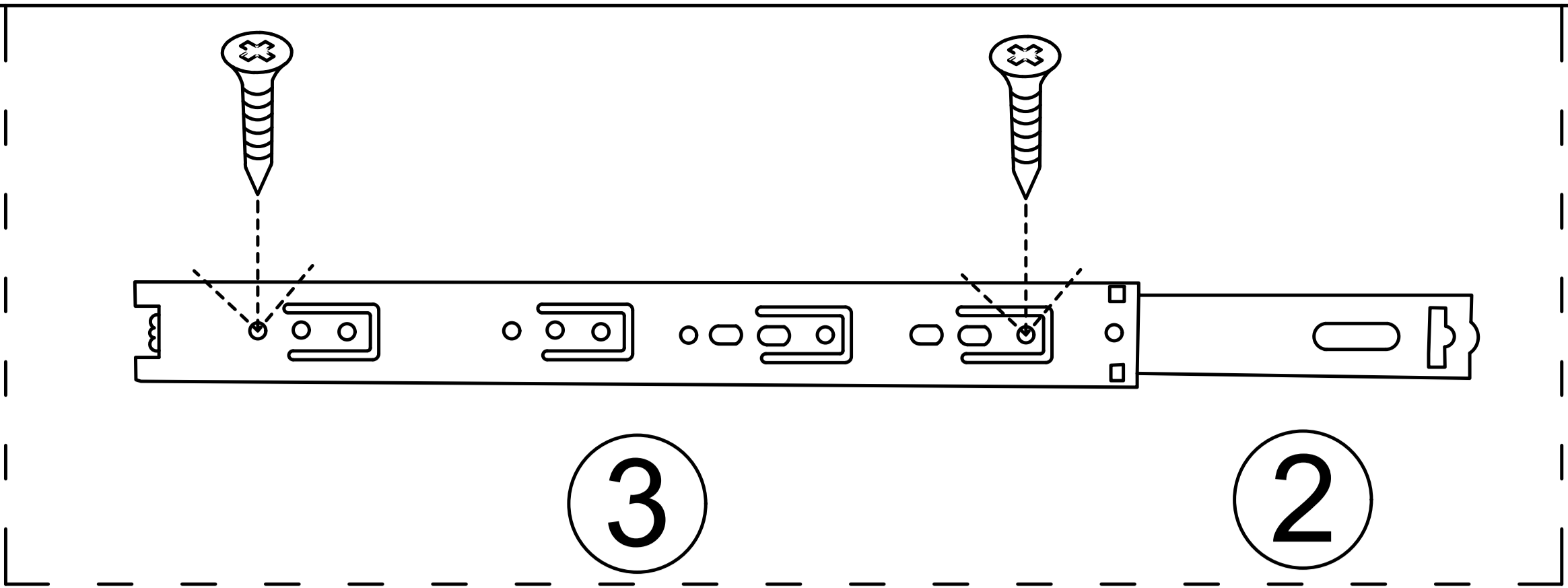

Step 18

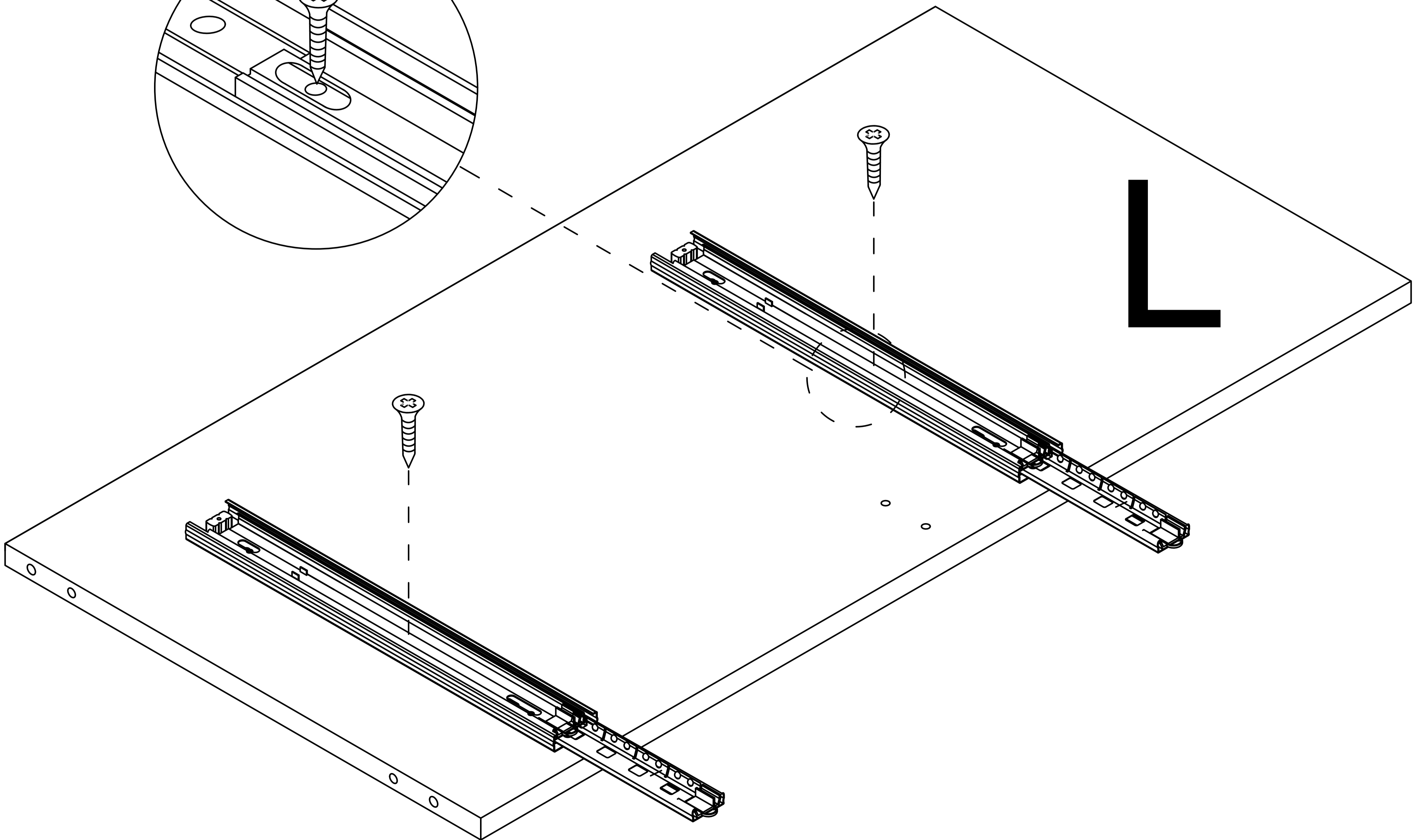
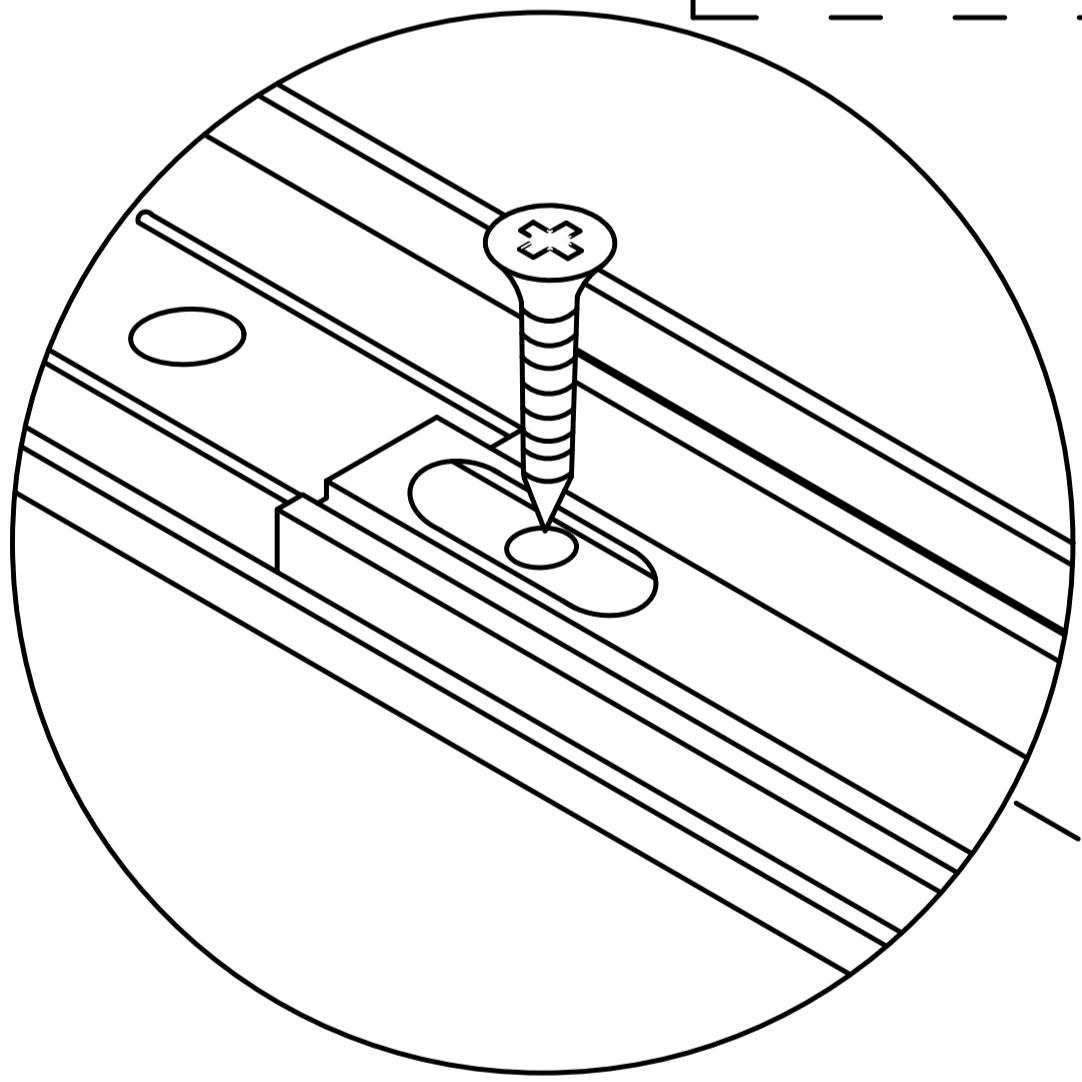
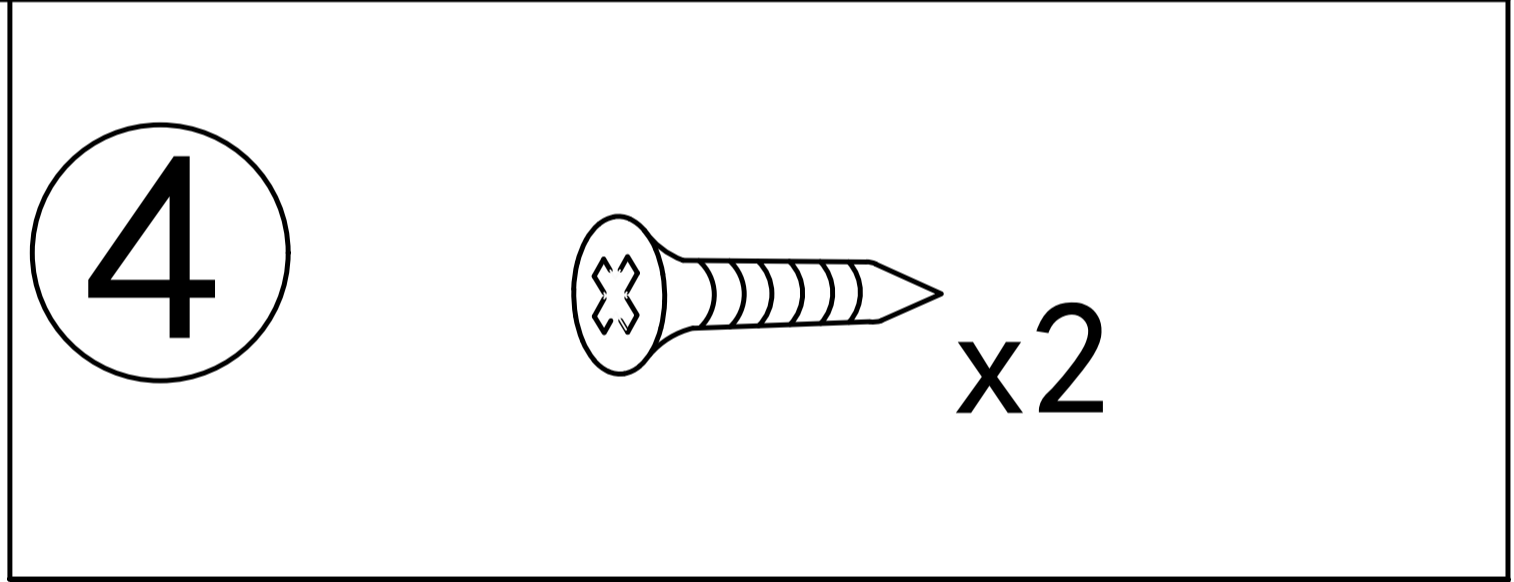
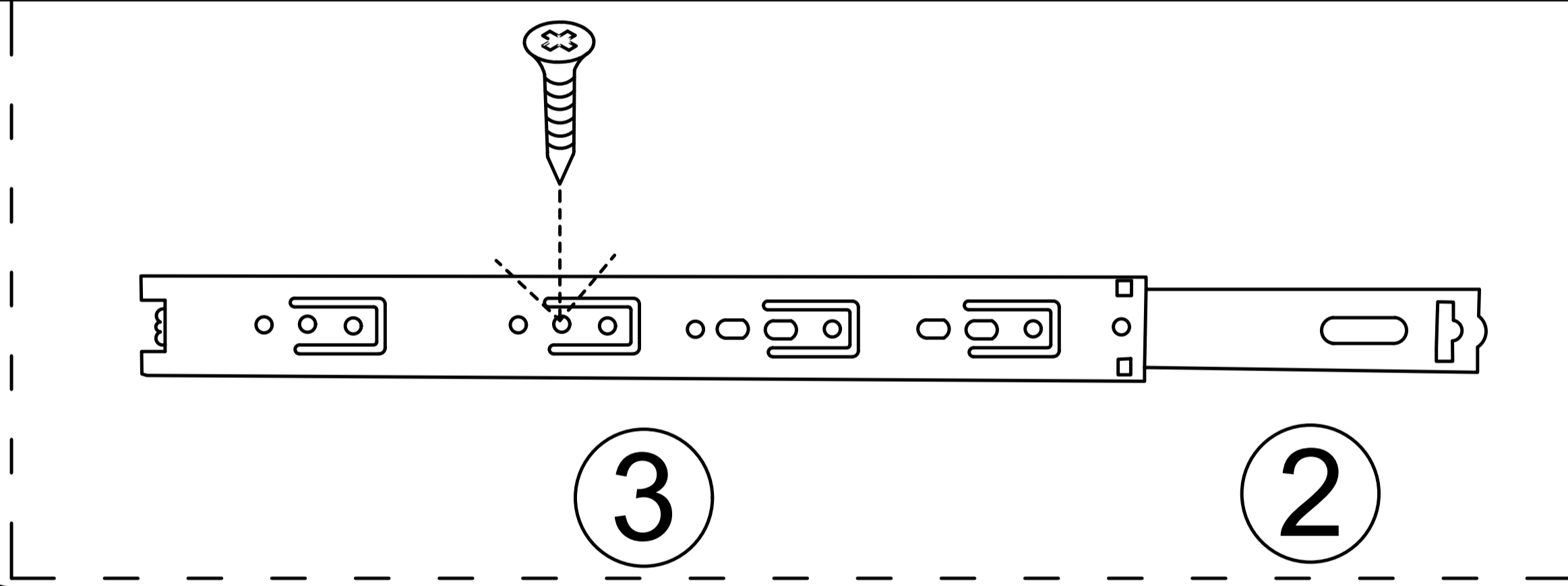

Step 19

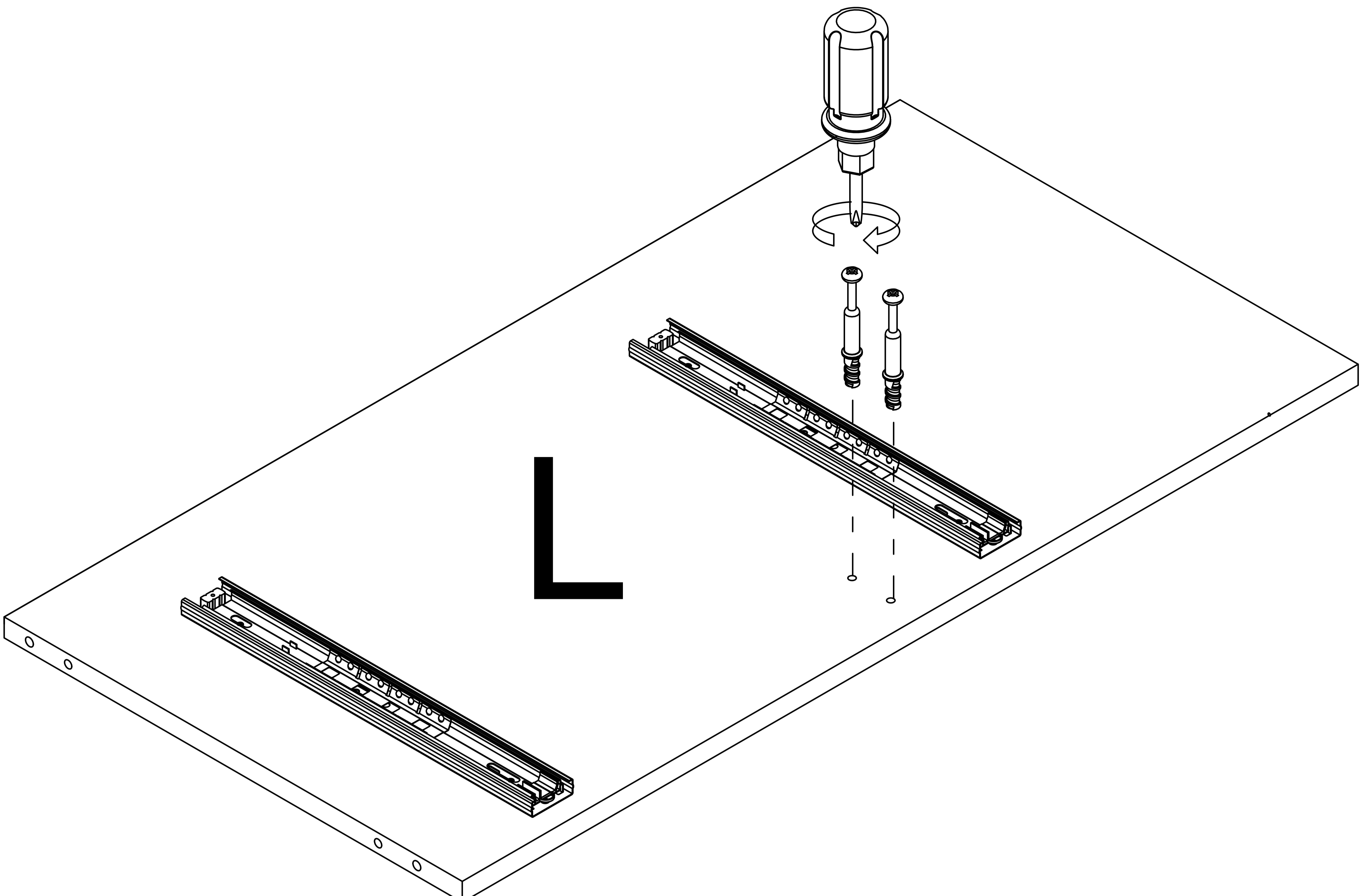
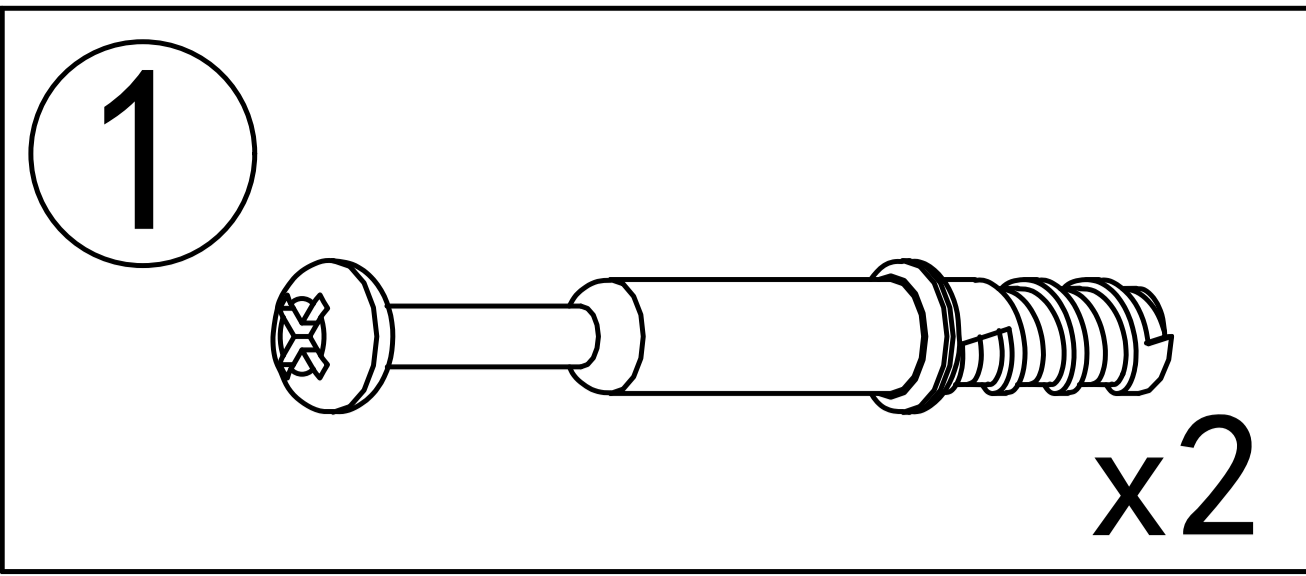

Step 20

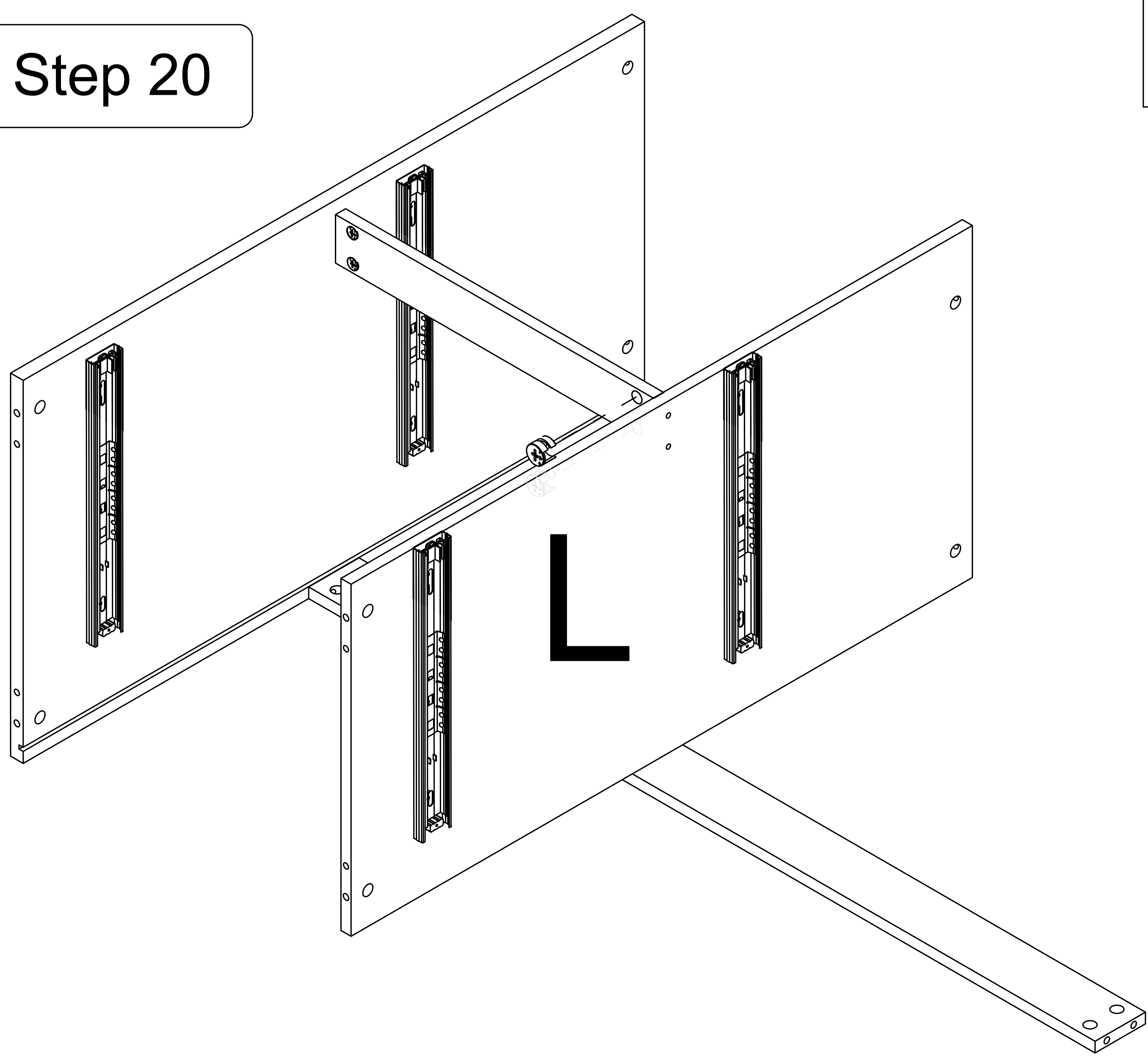
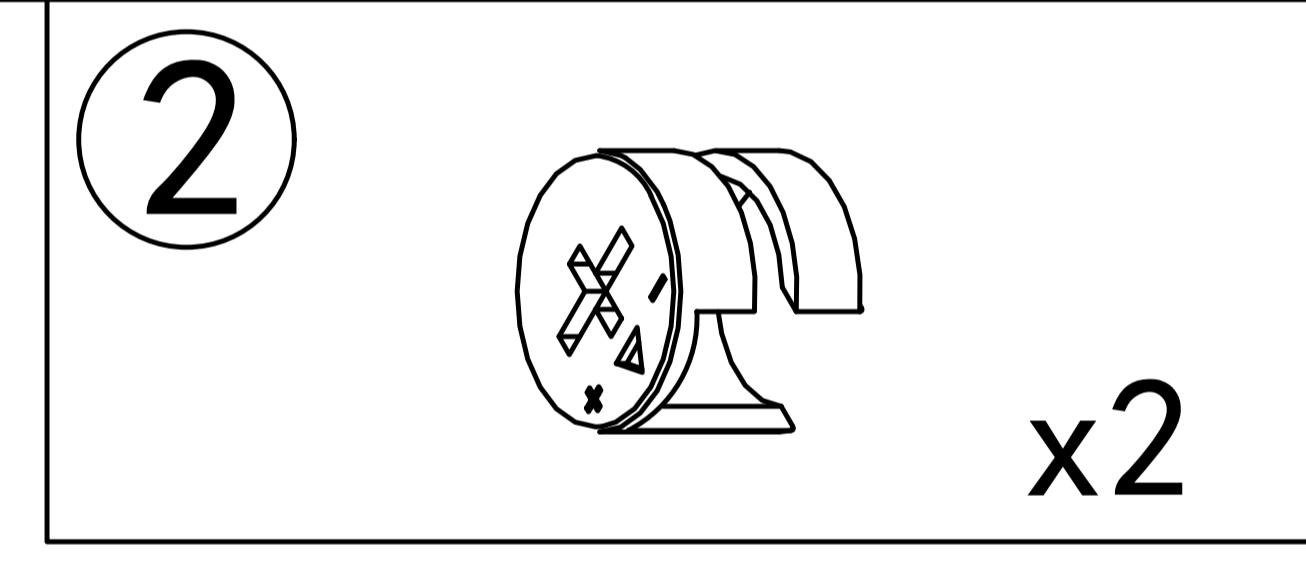

Step 21

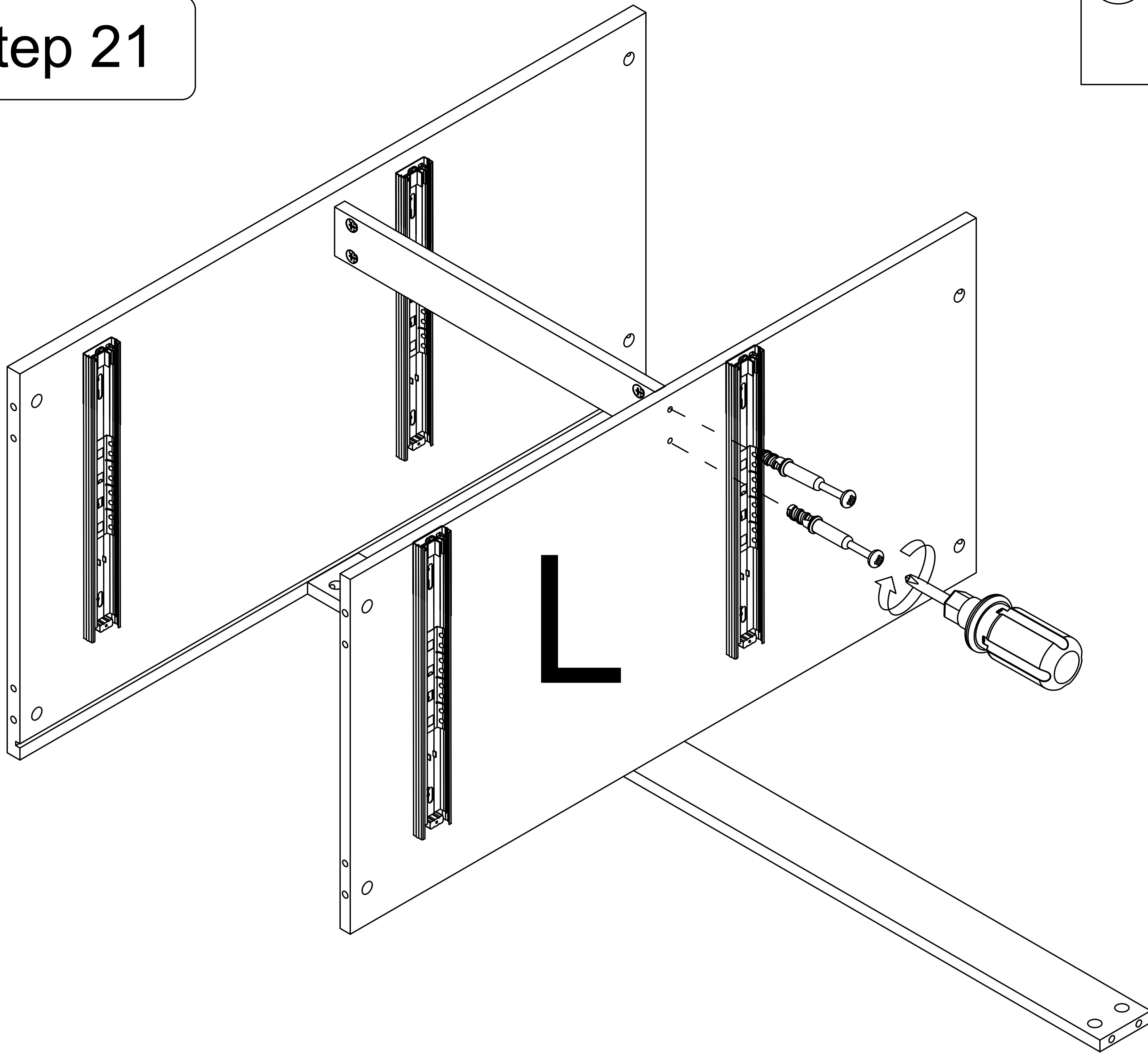
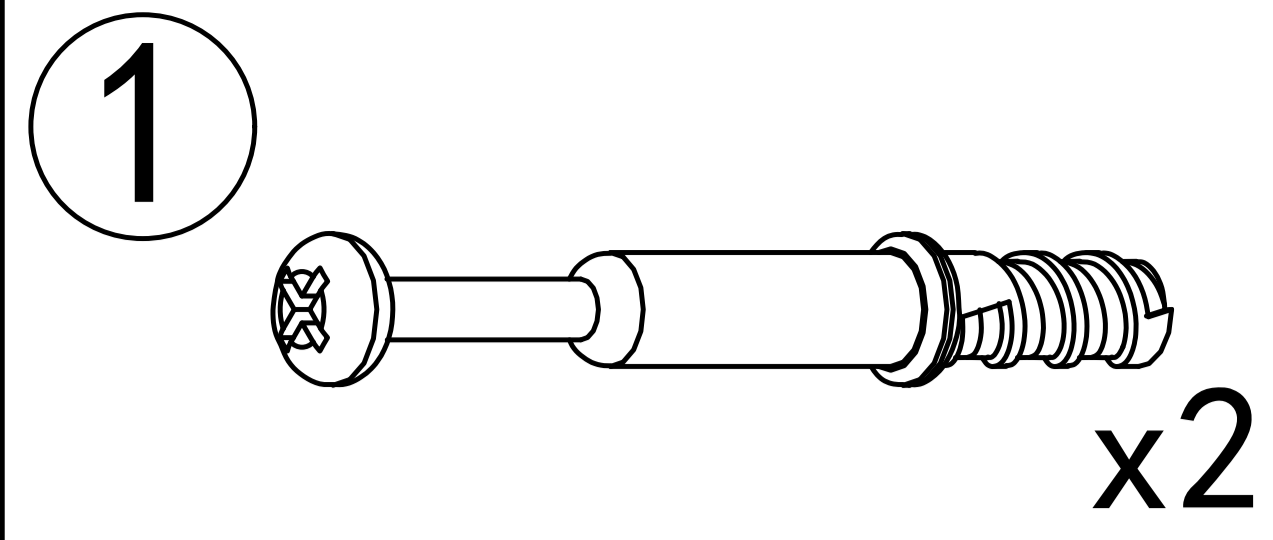

Step 22

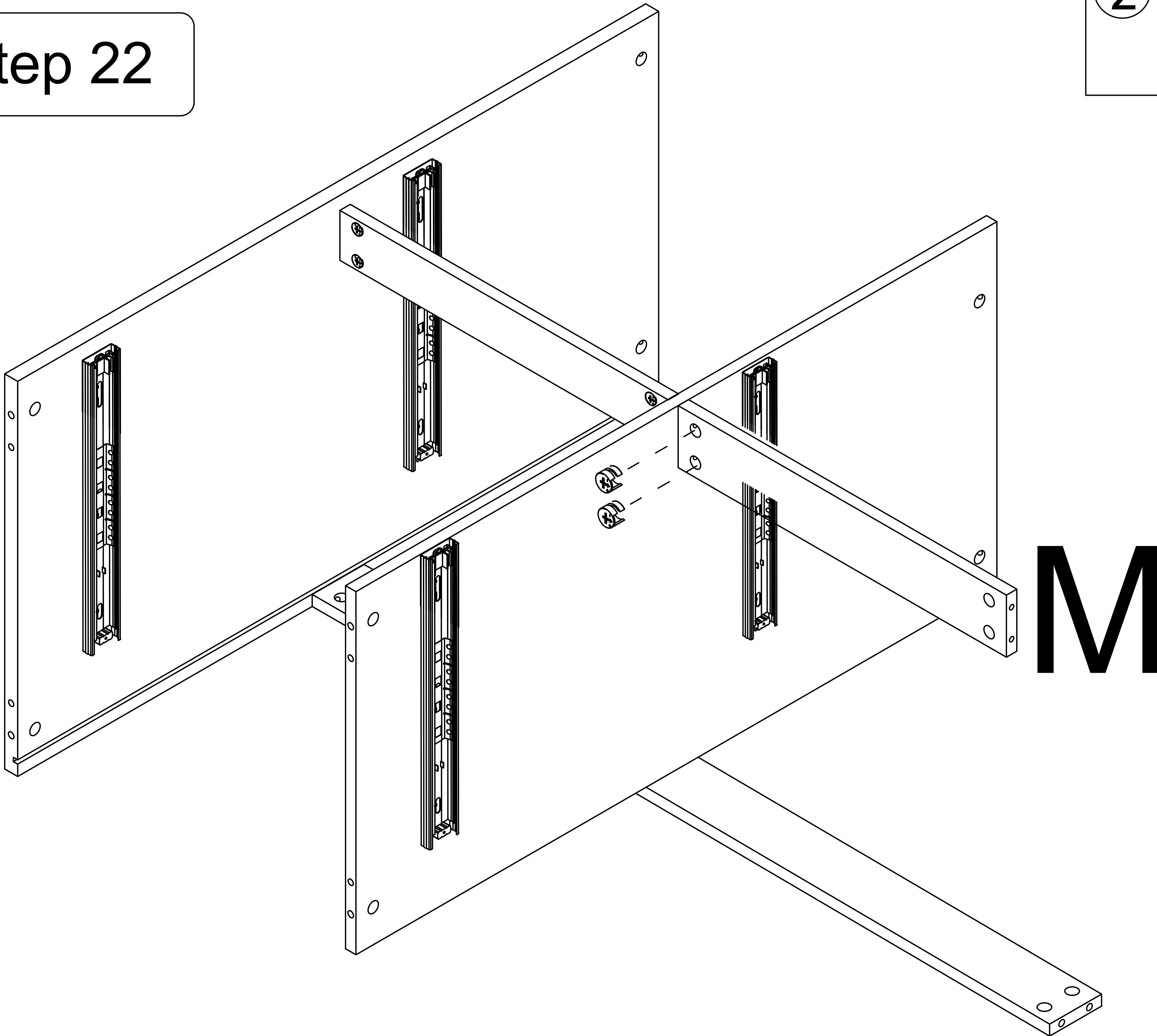
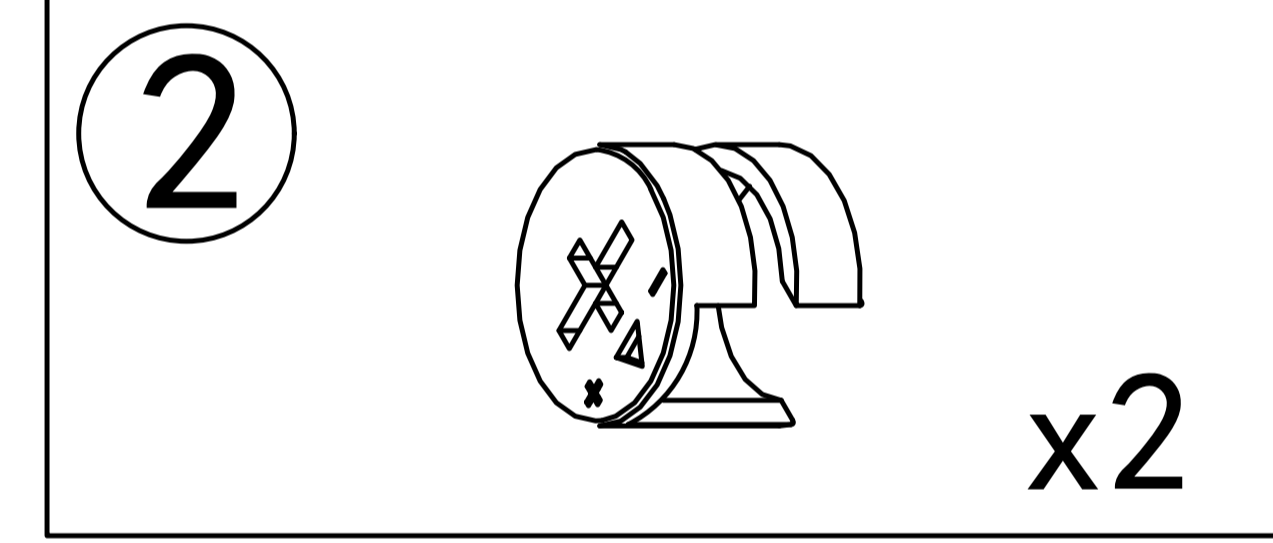

Step 23

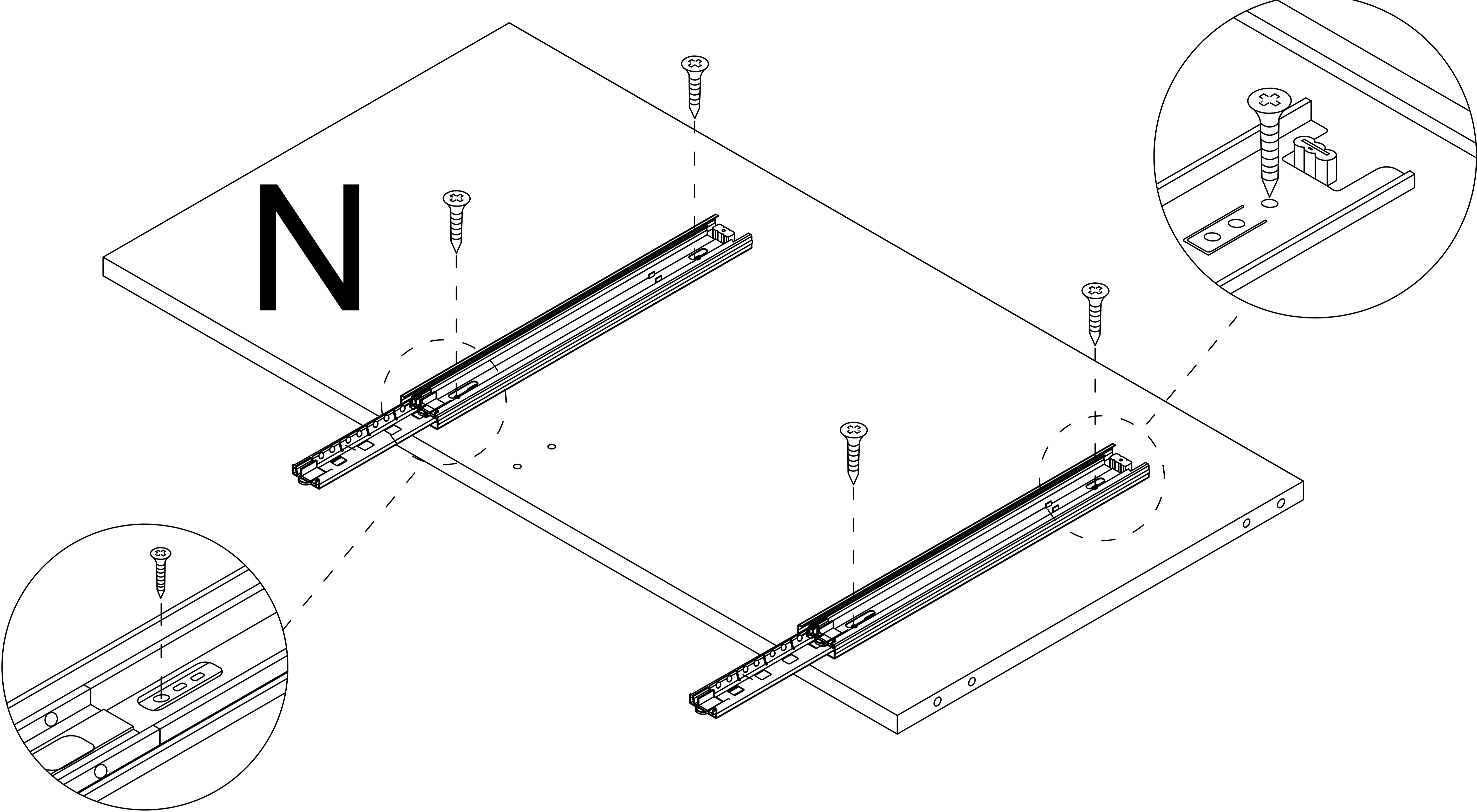
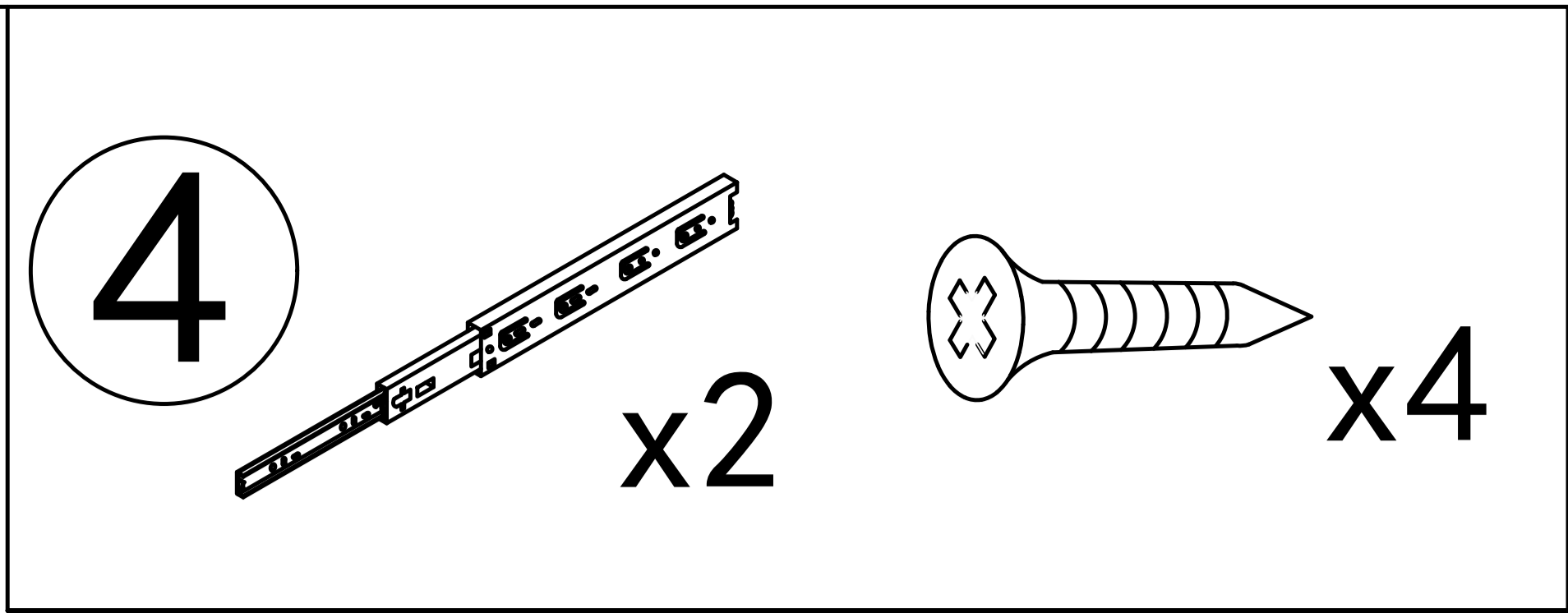
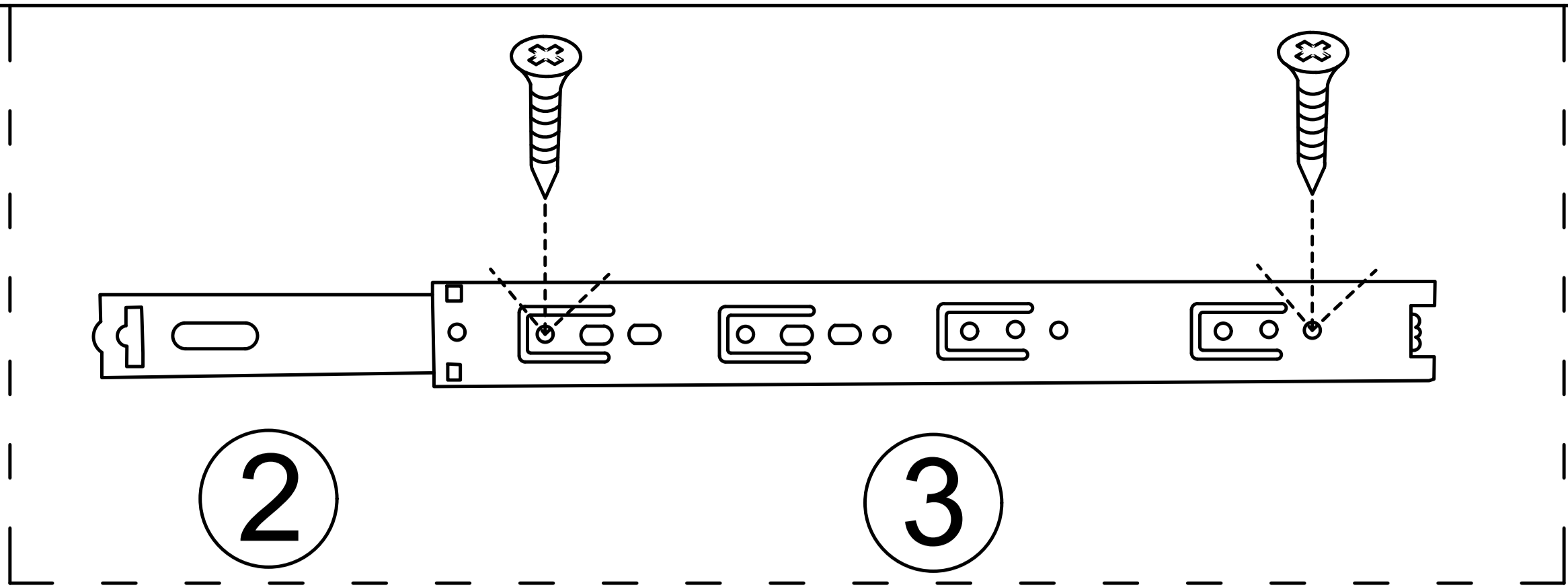

Step 24

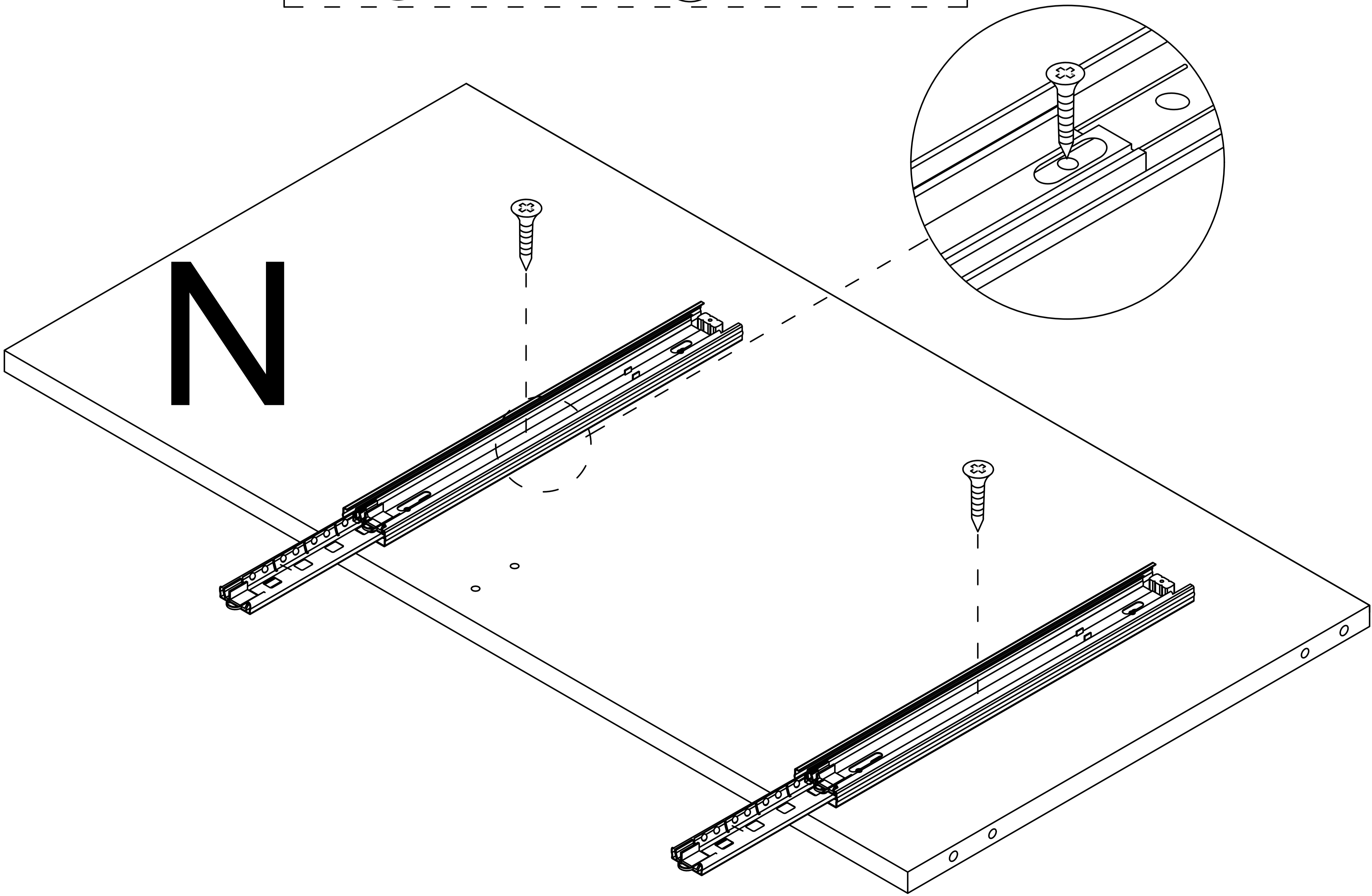
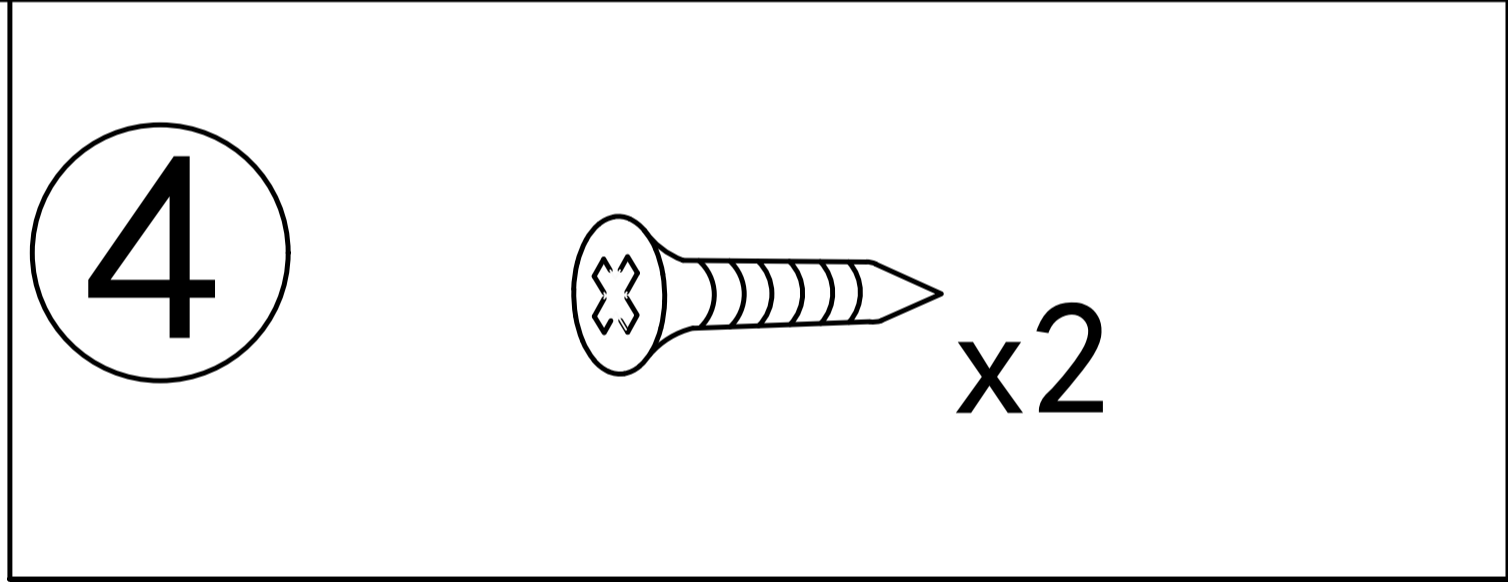
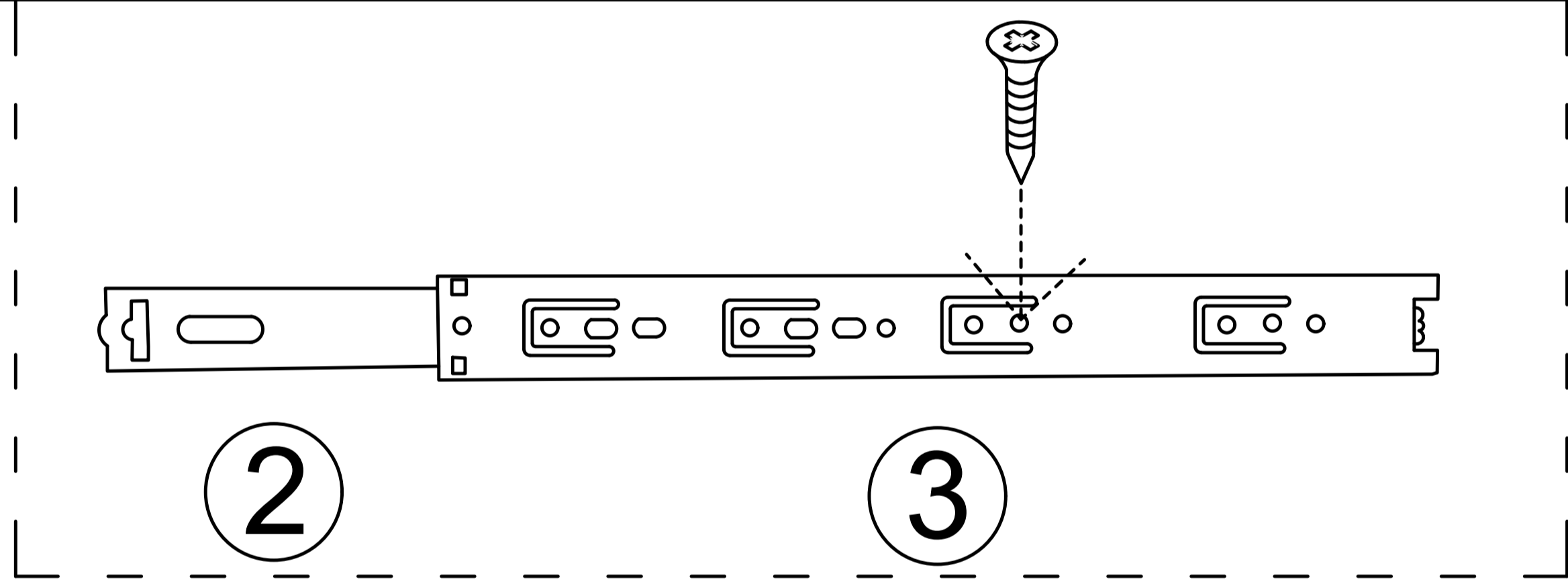

Step 25

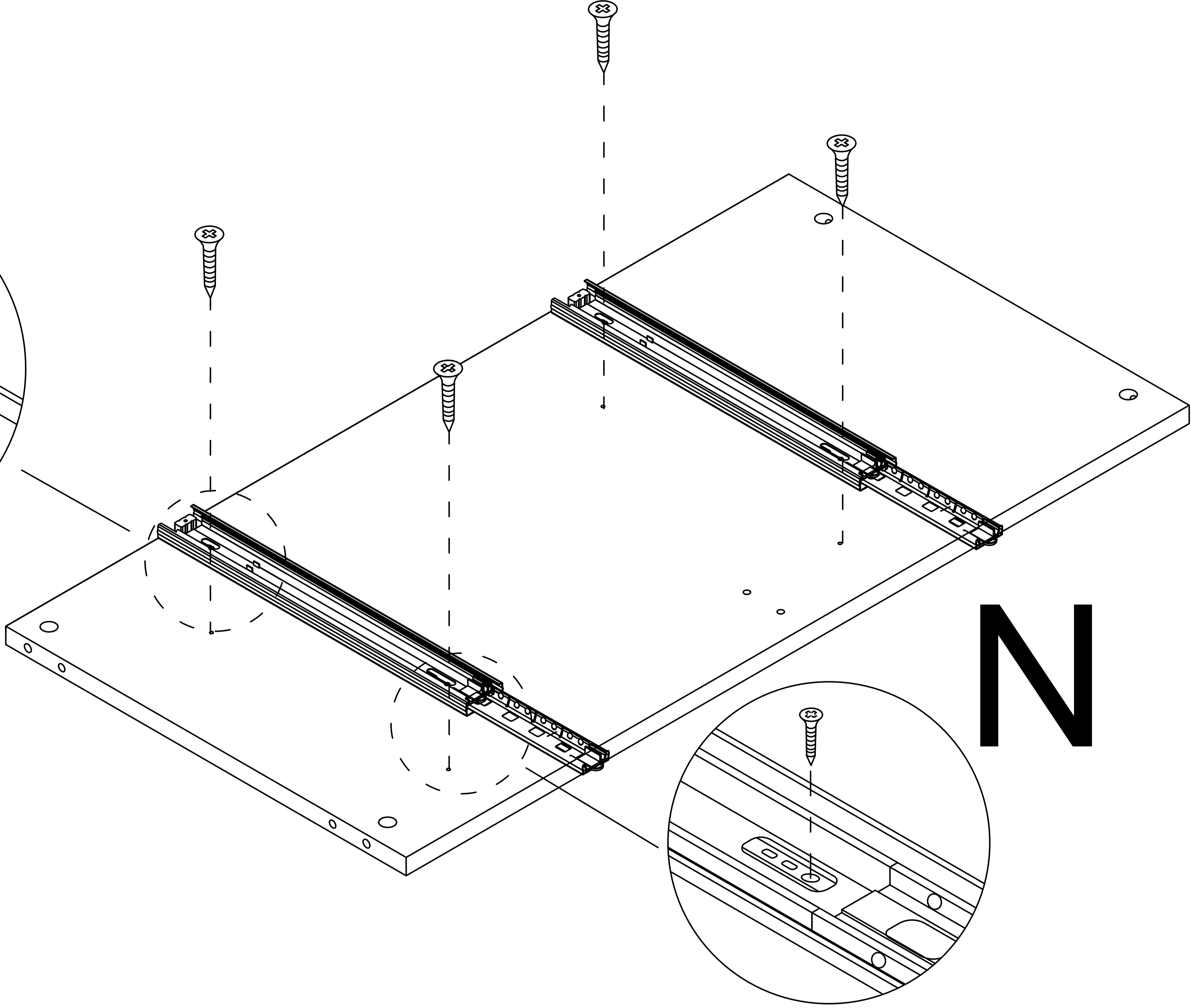
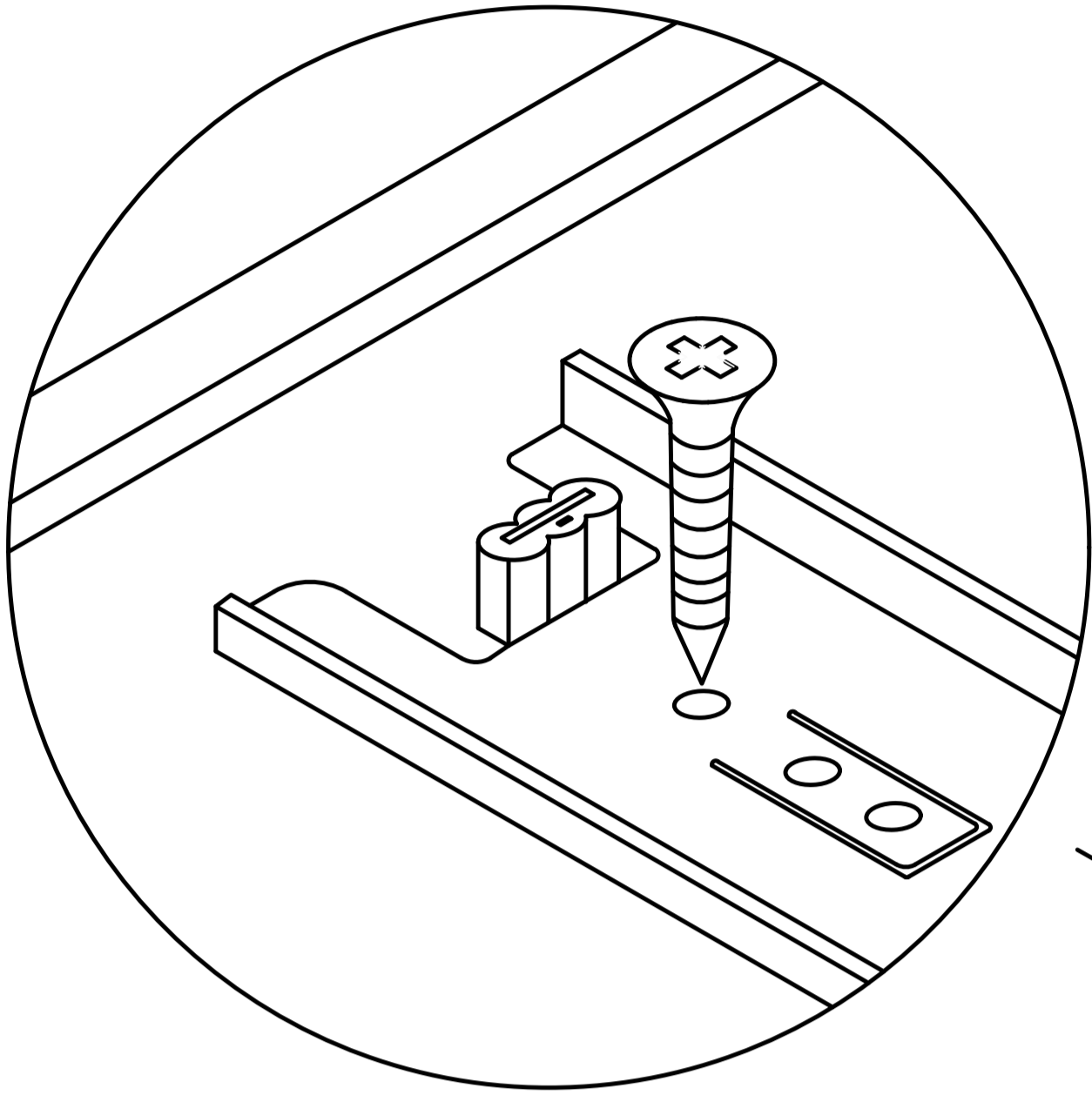
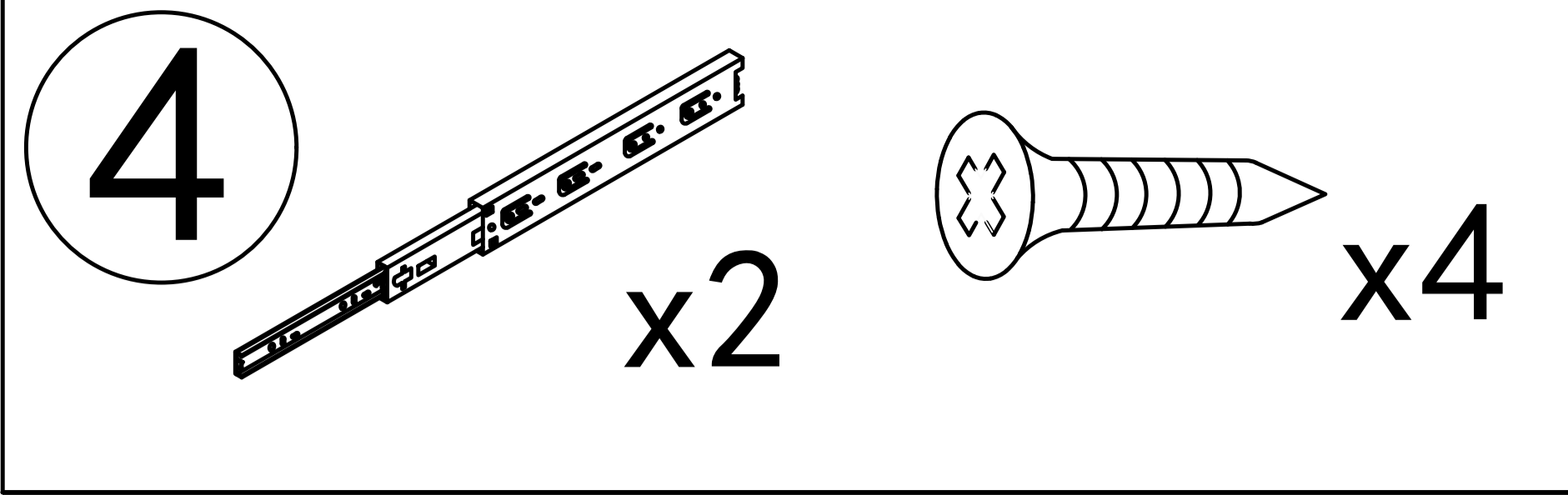
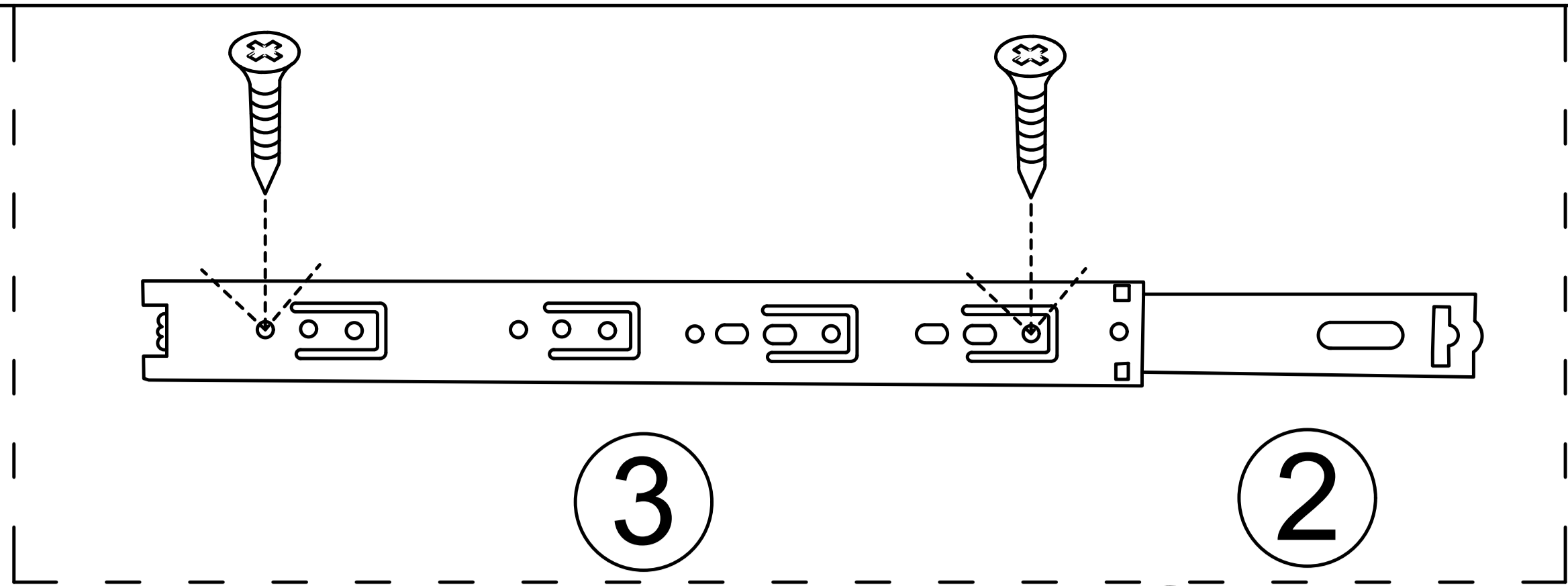

Step 26

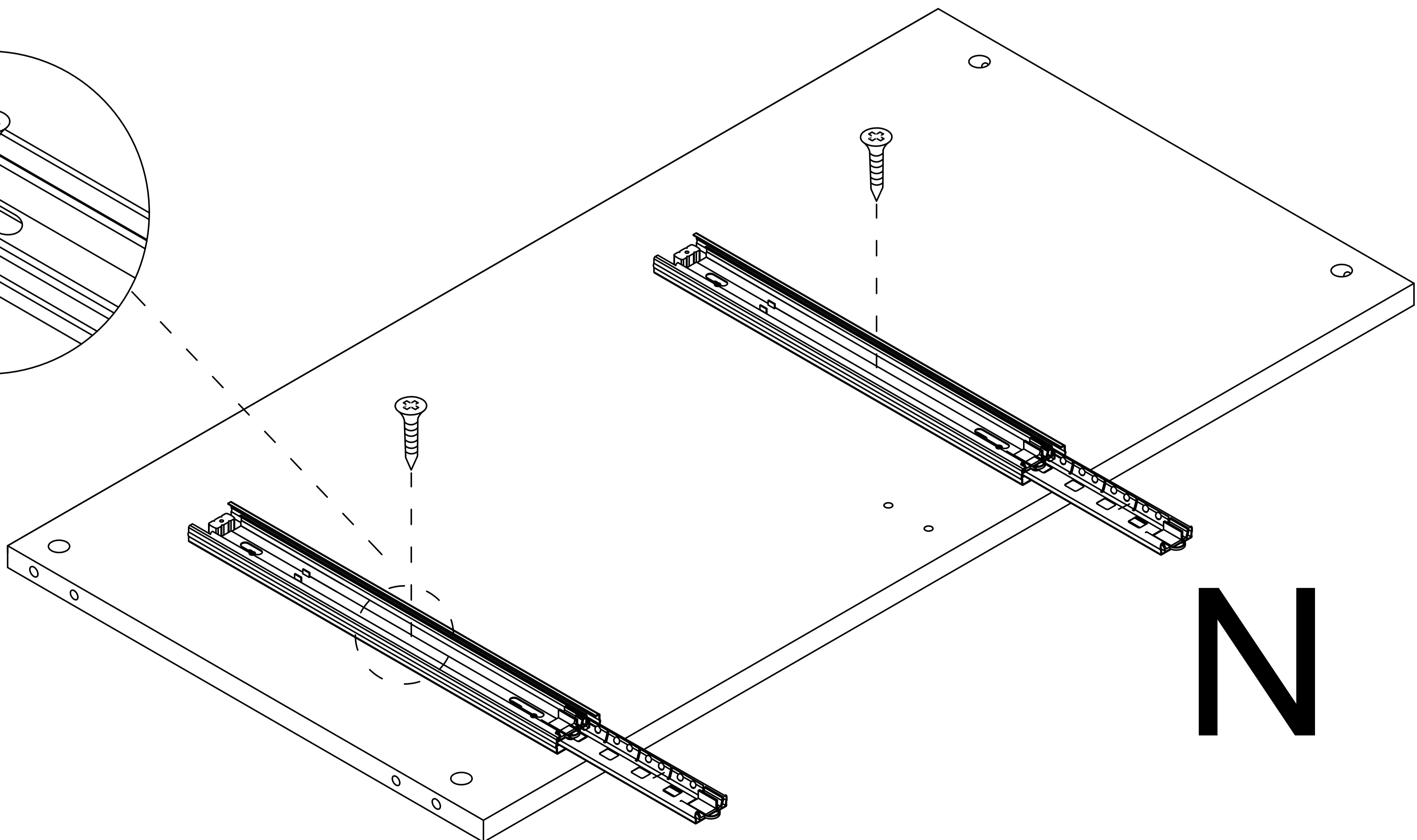
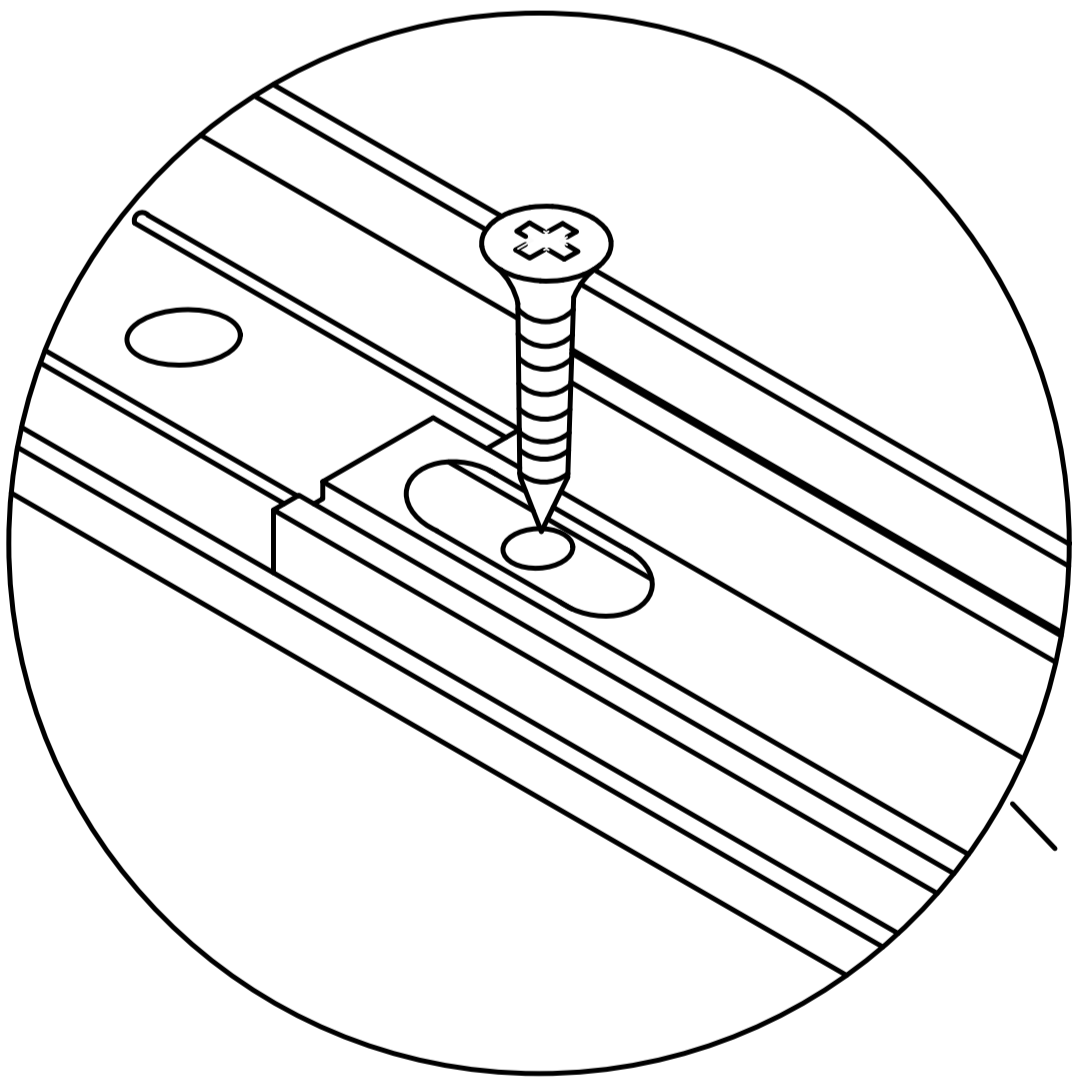
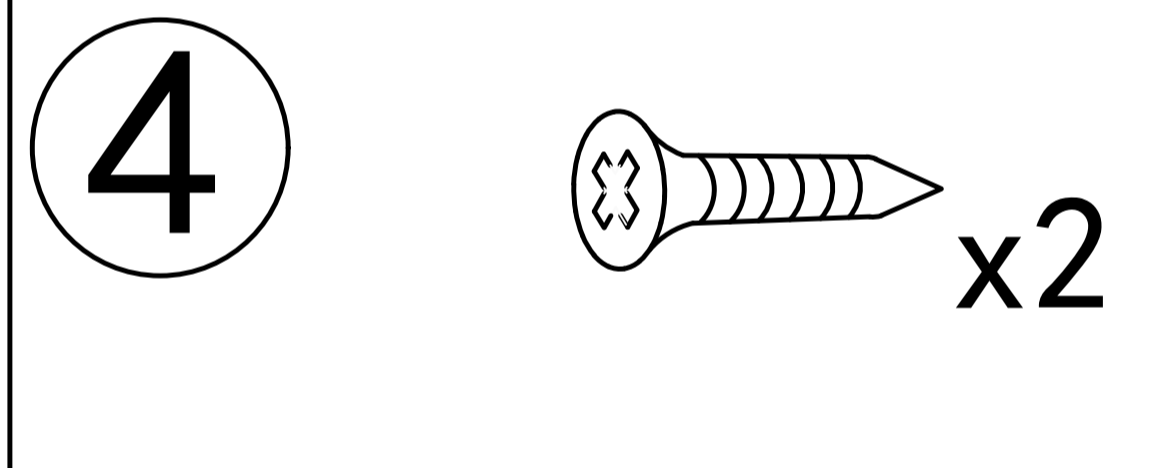
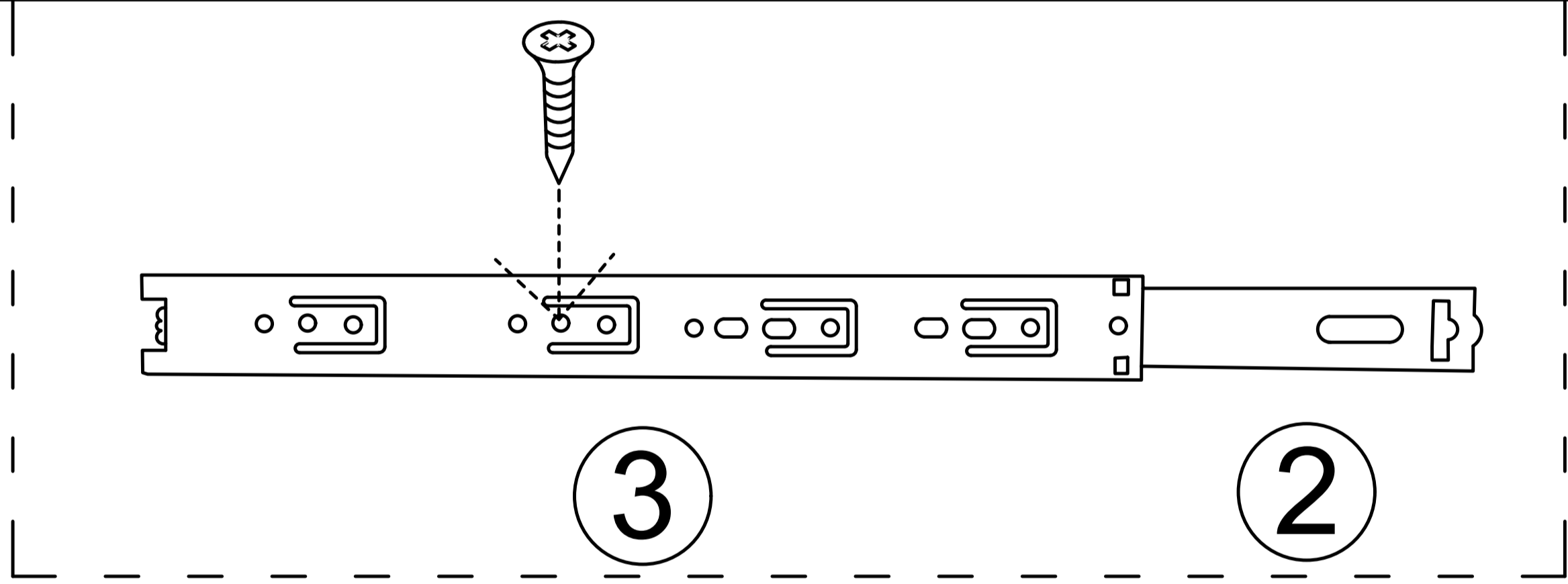

Step 27

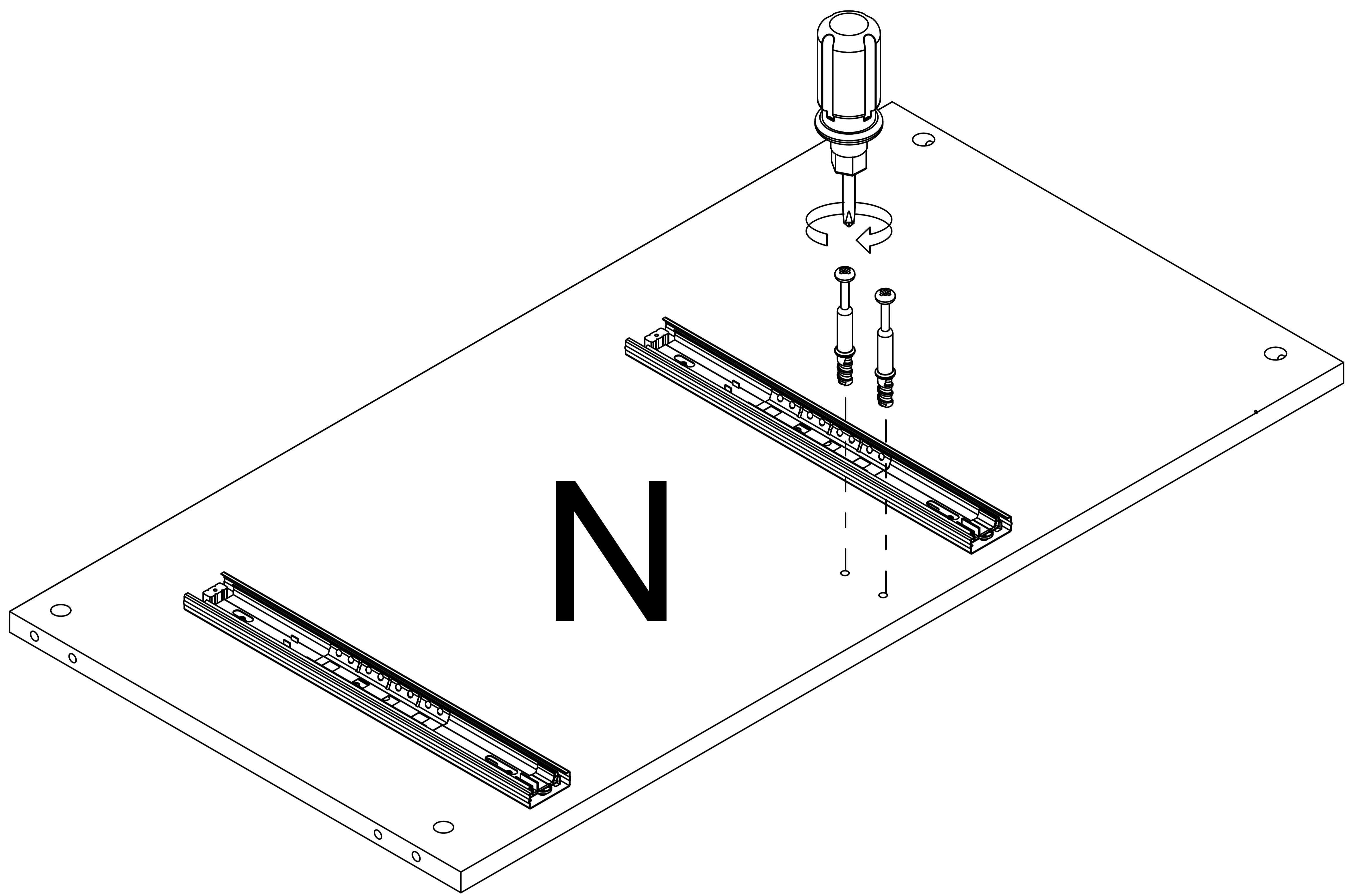
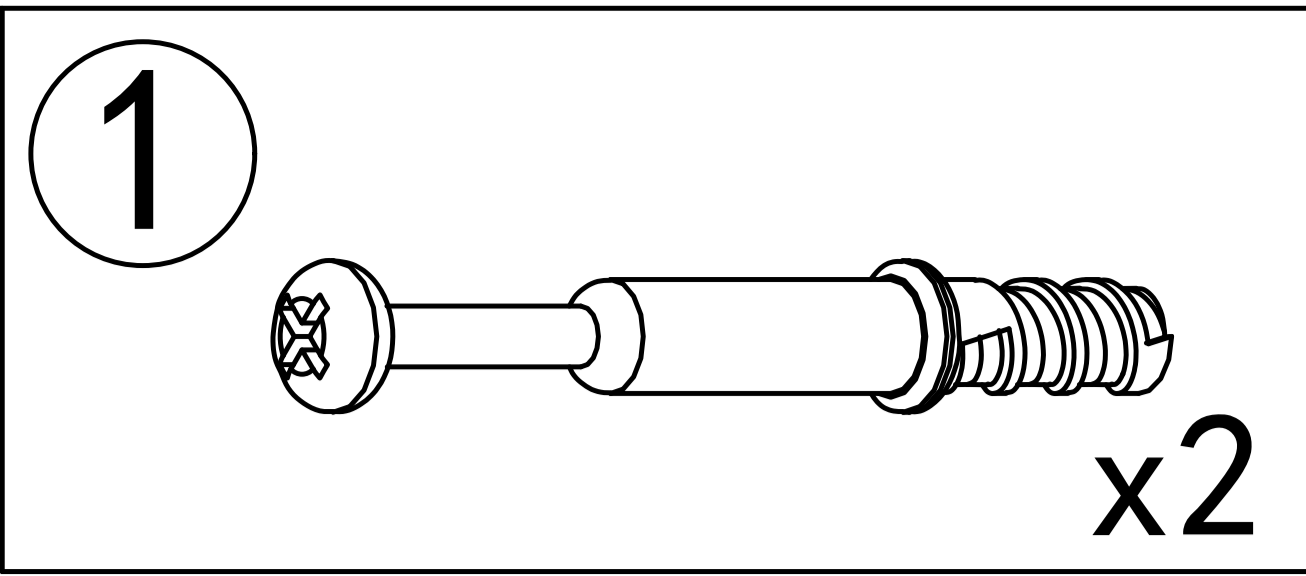

Step 28

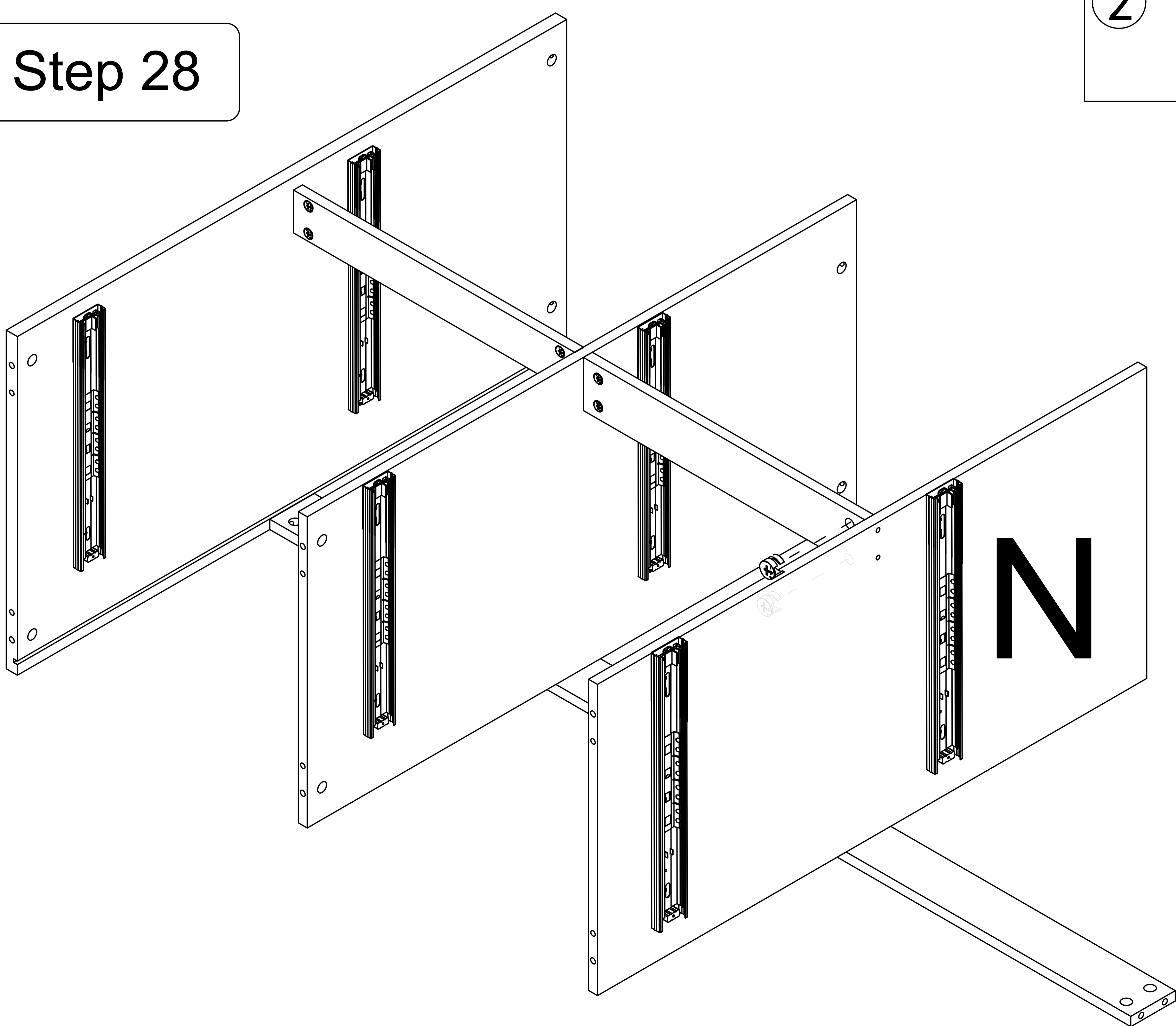
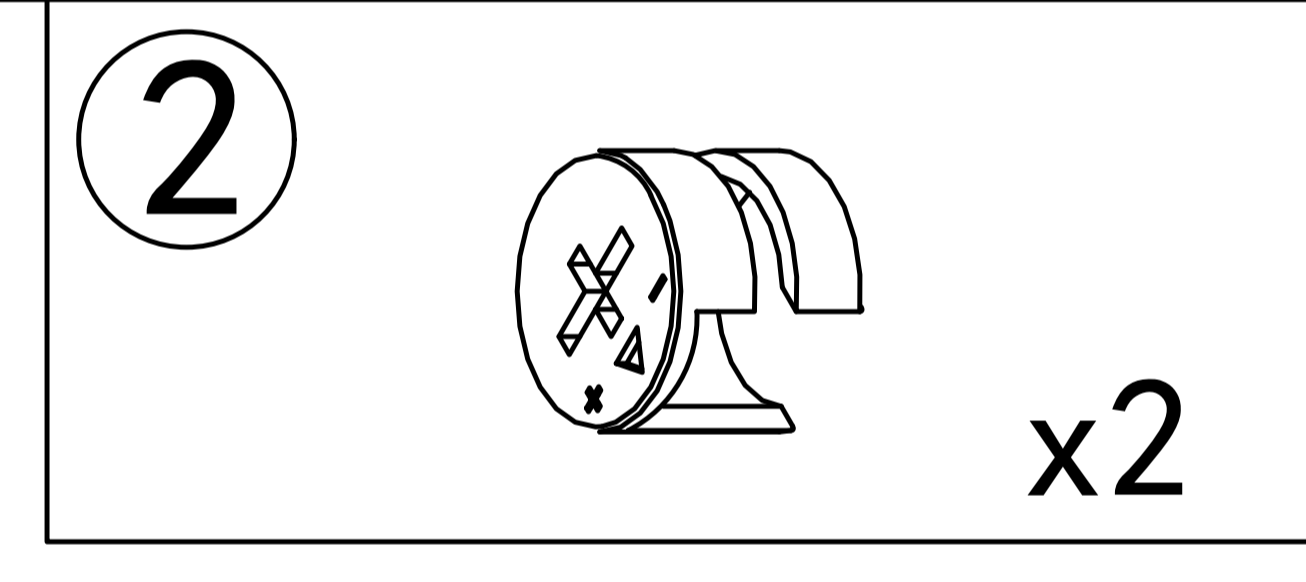

Step 29

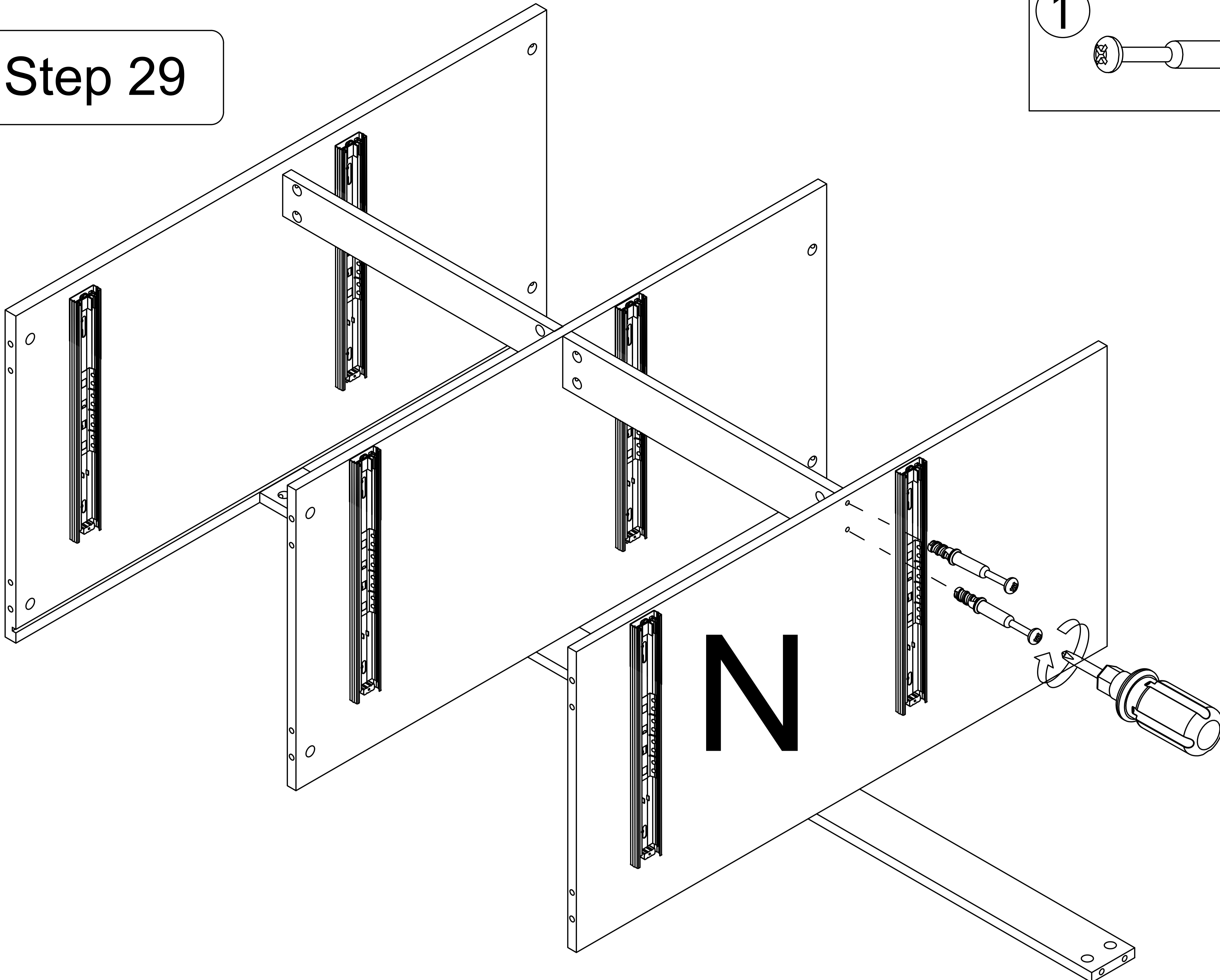
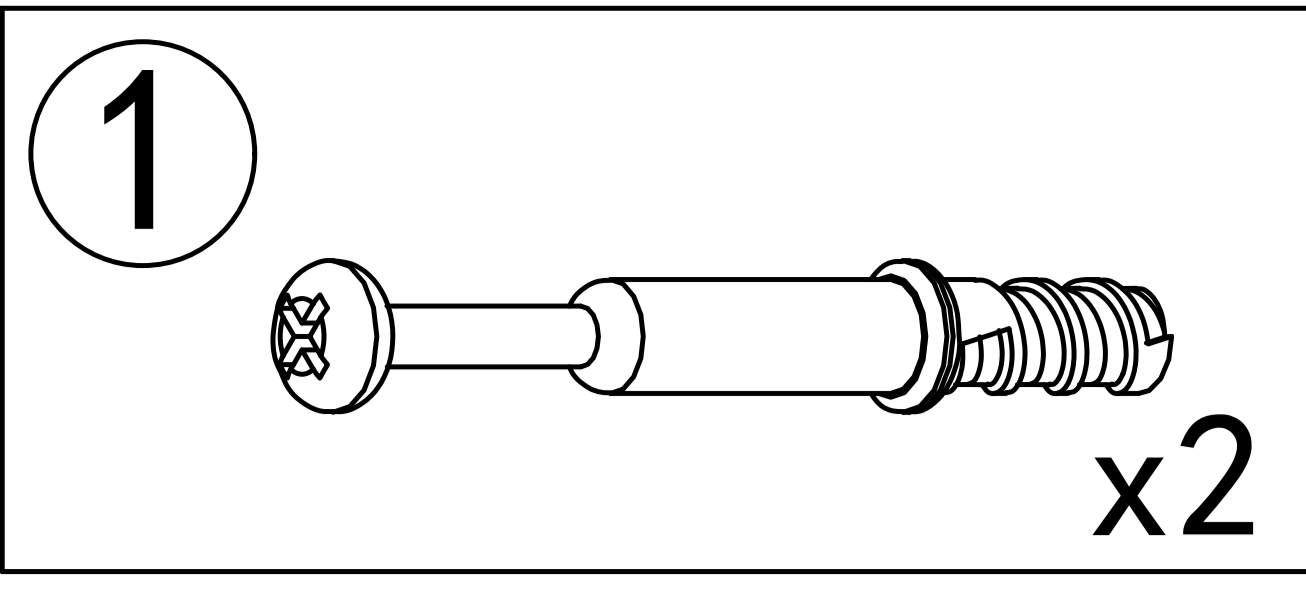

Step 30

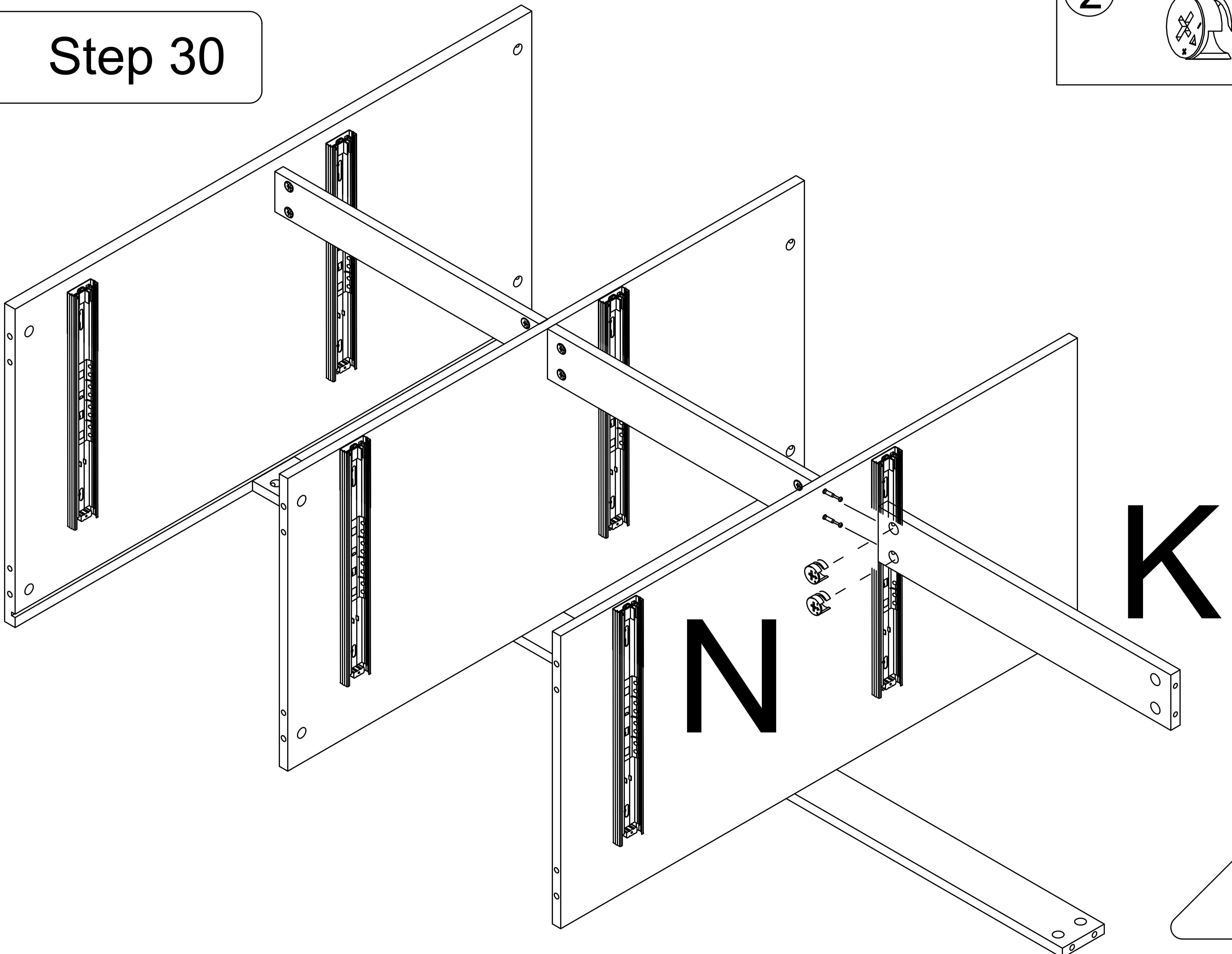
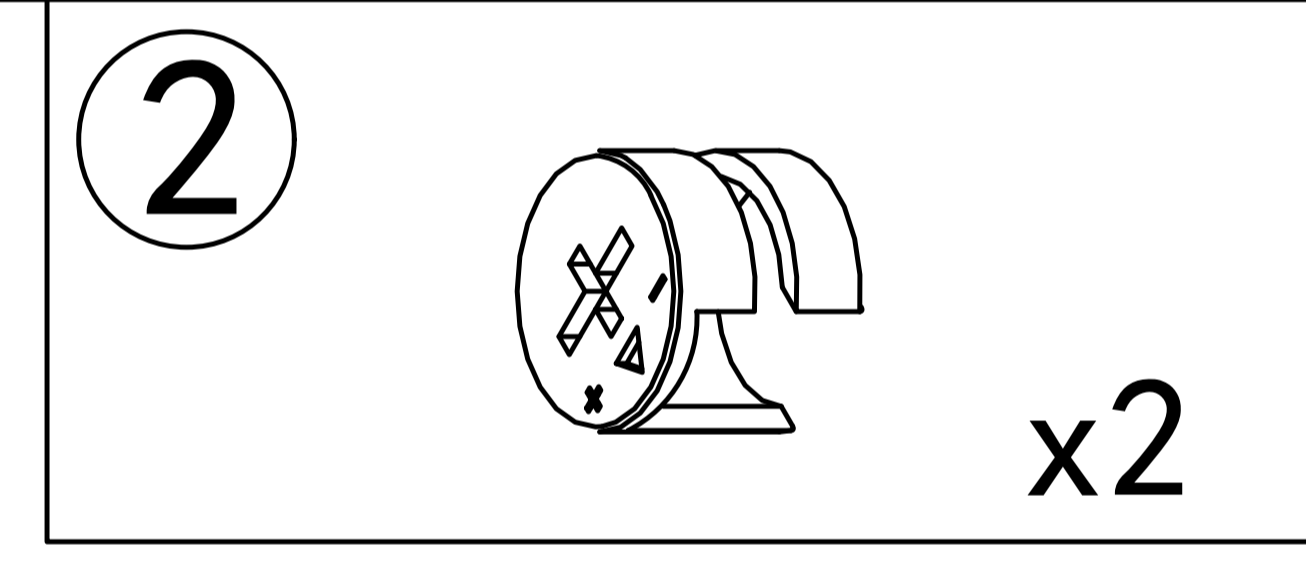

Step 31

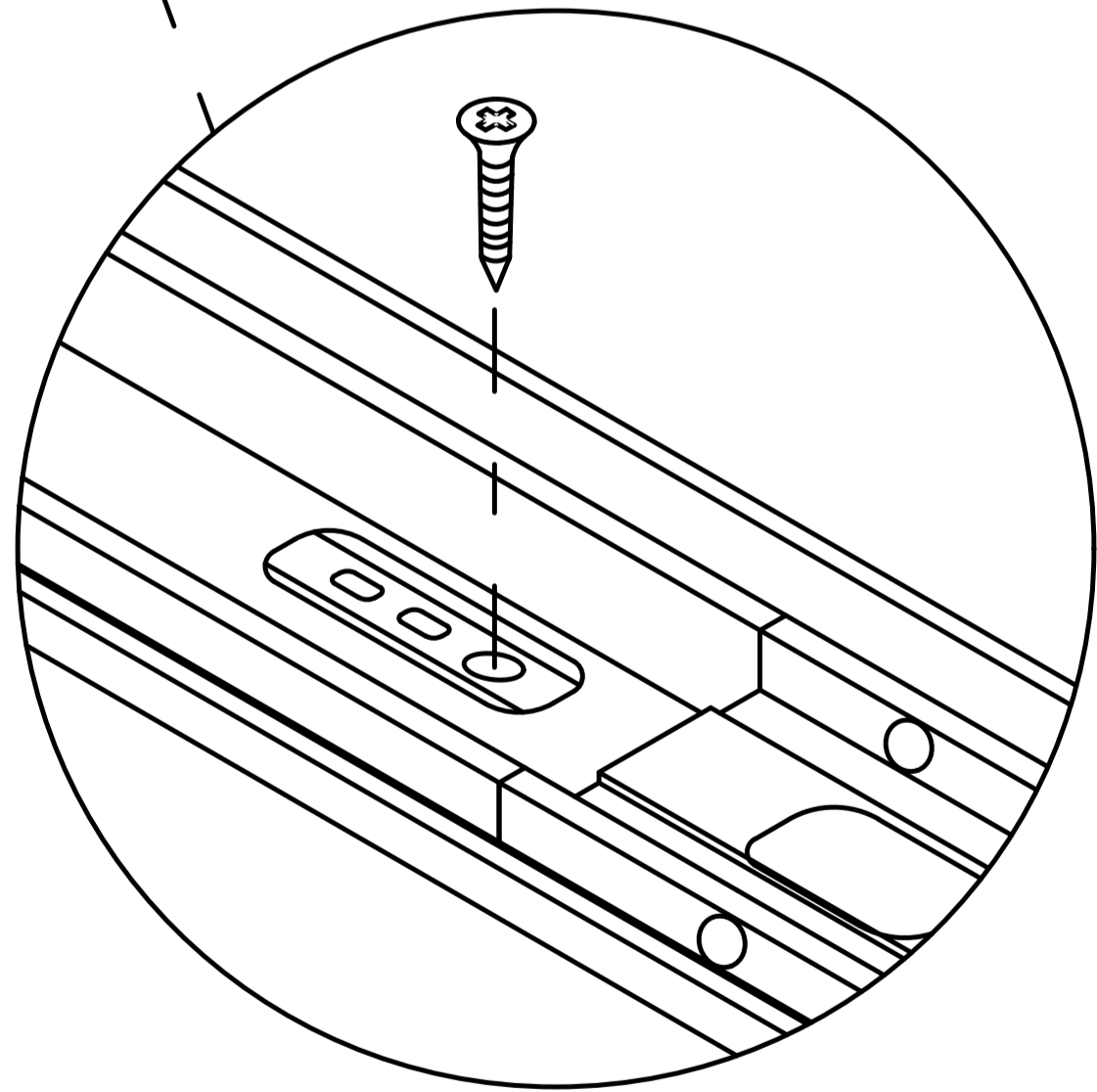
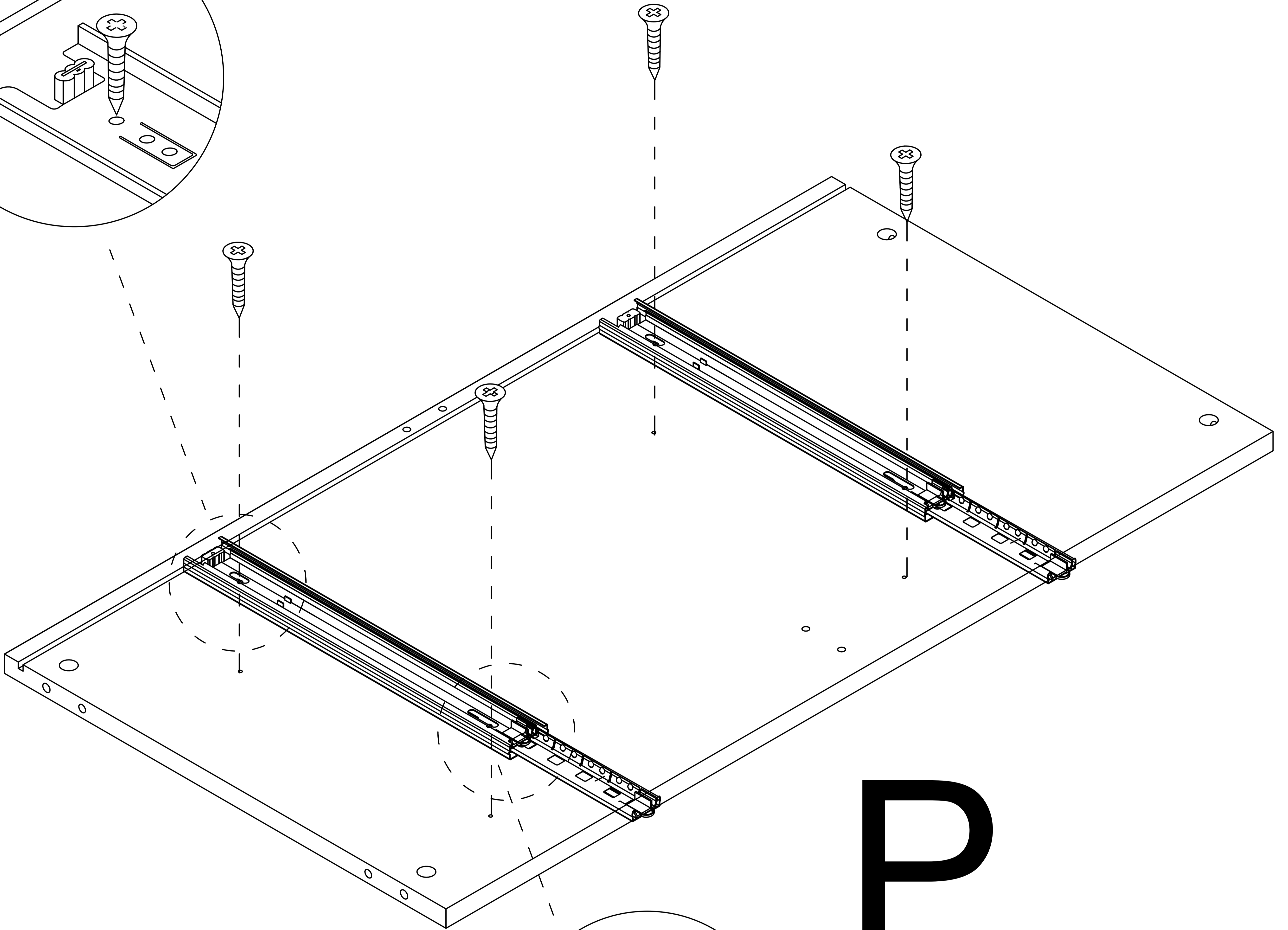
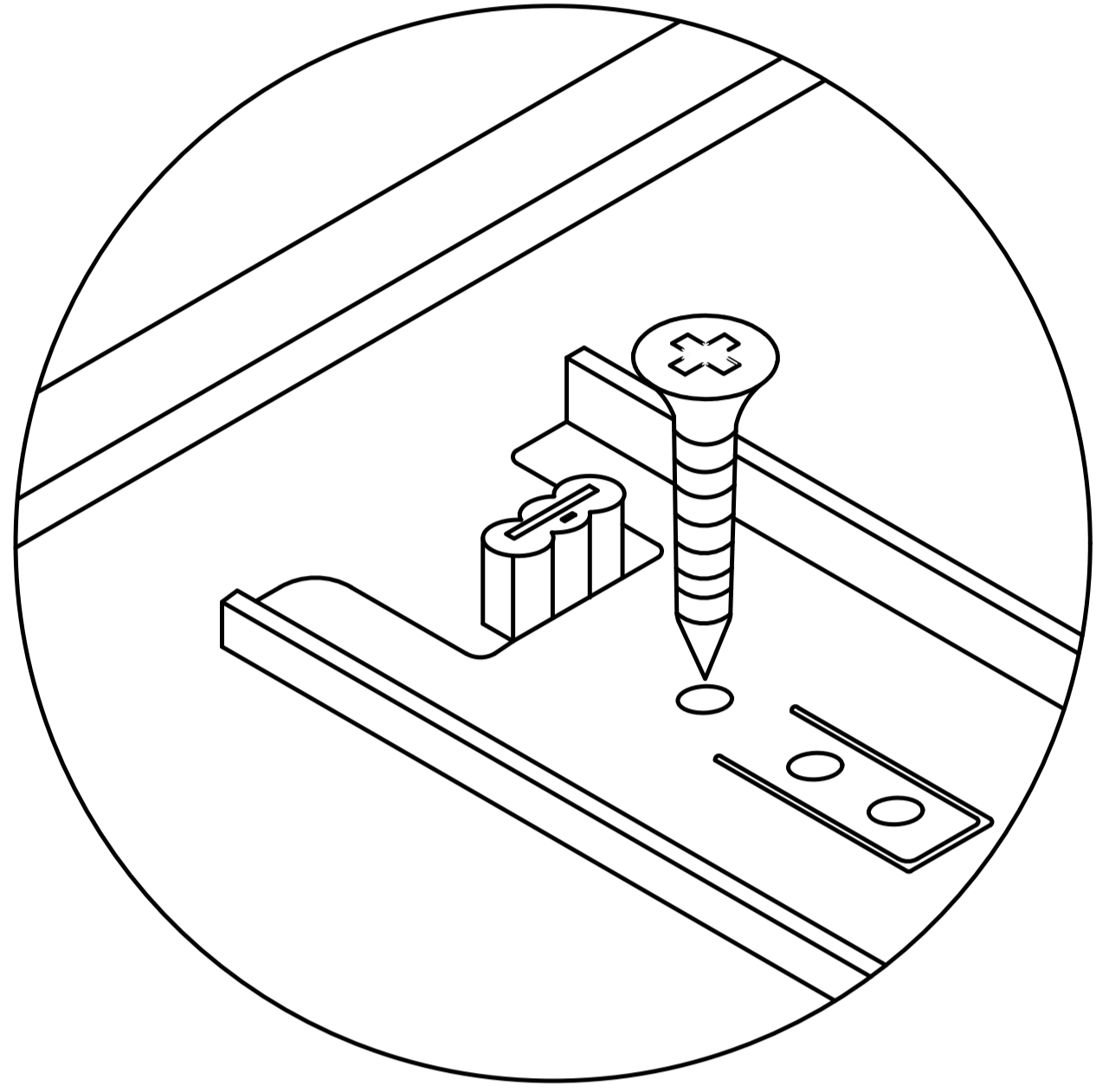
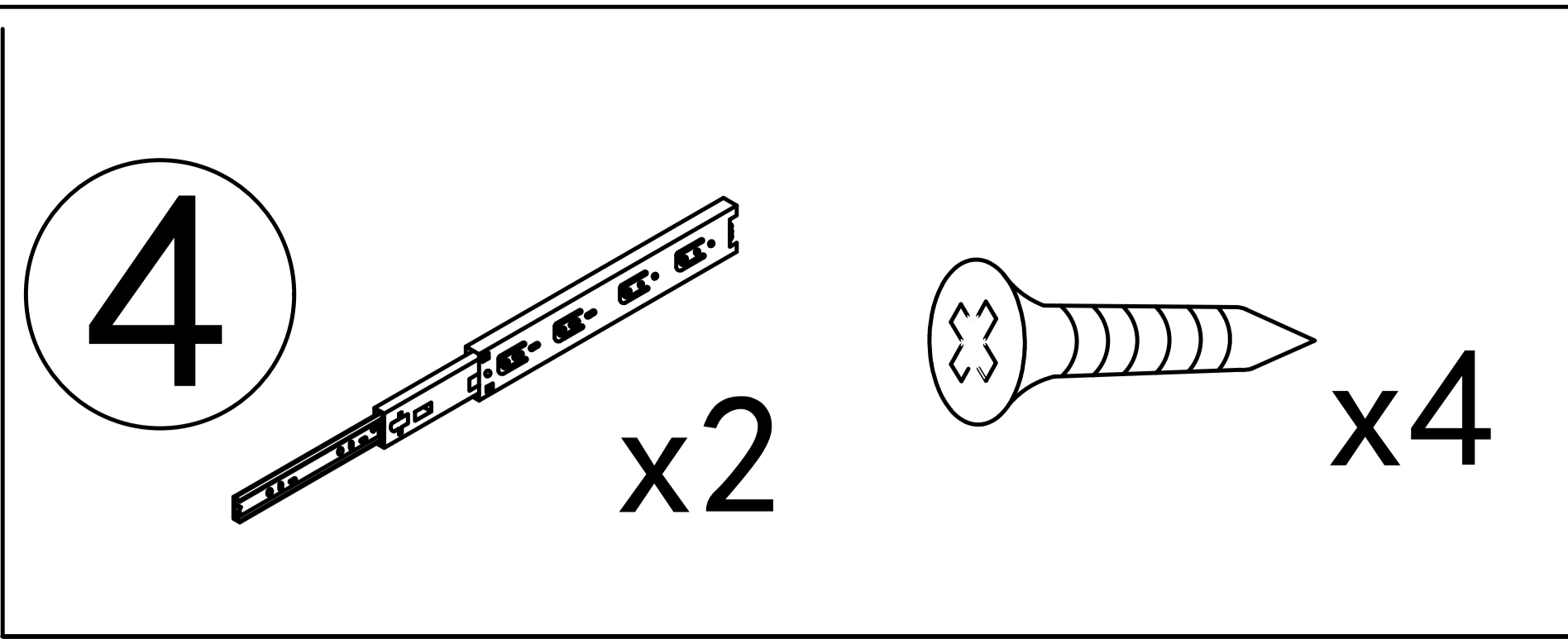
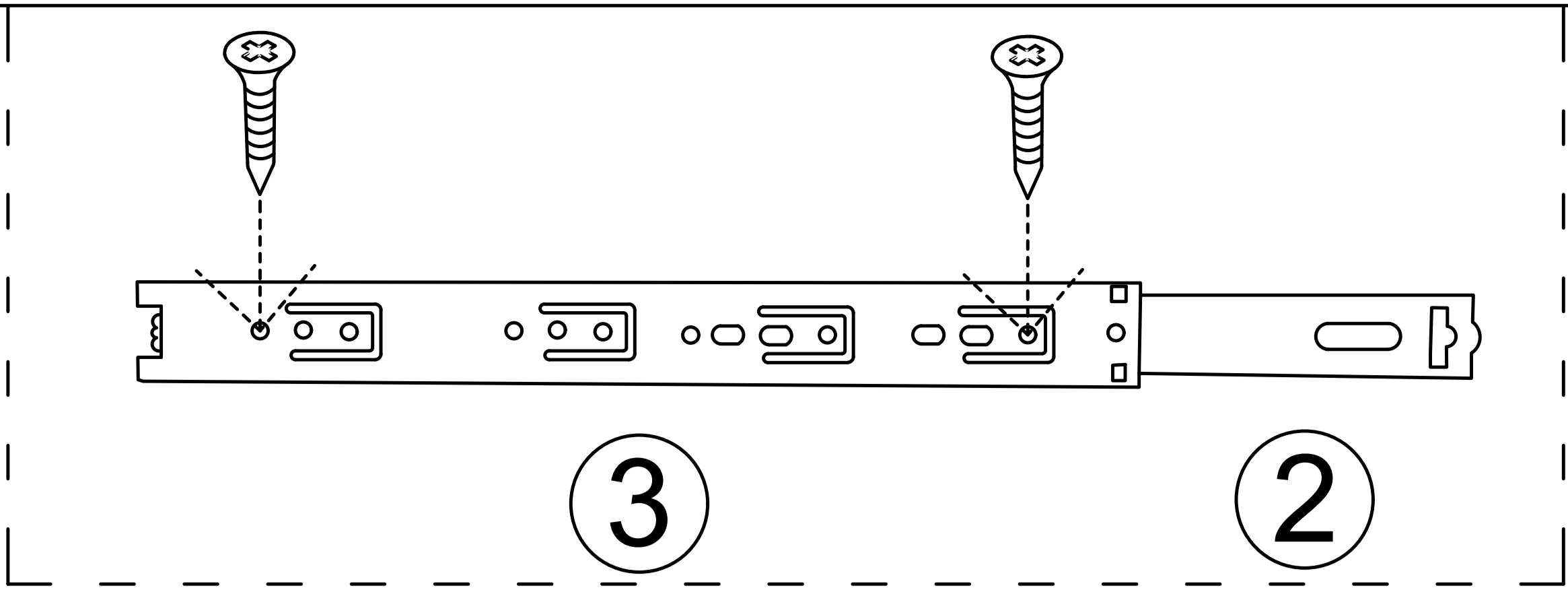

P

Step 32

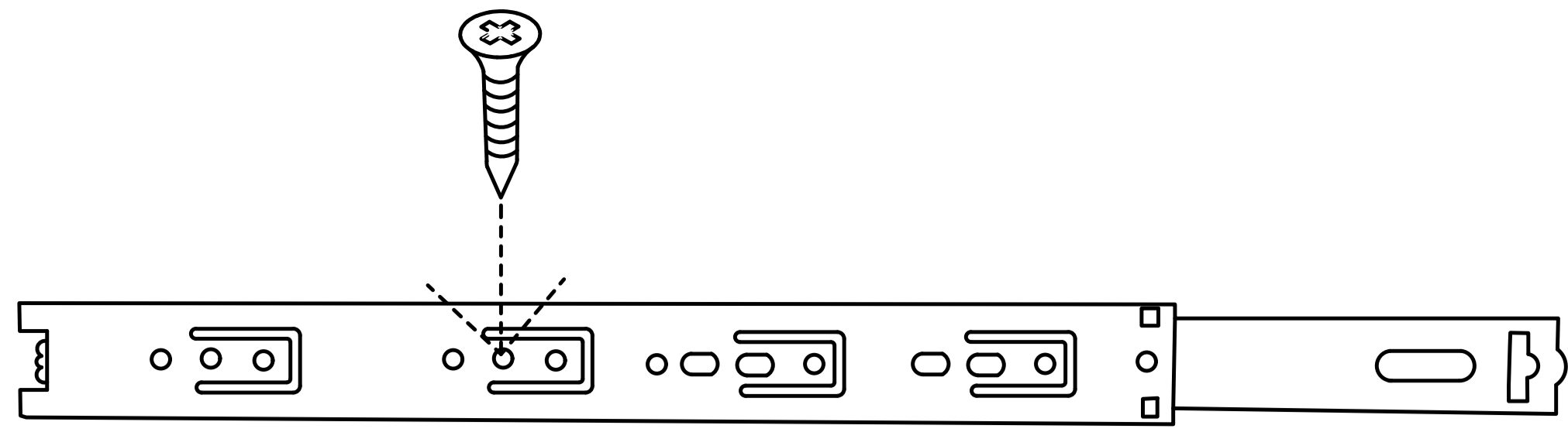

3

2

4

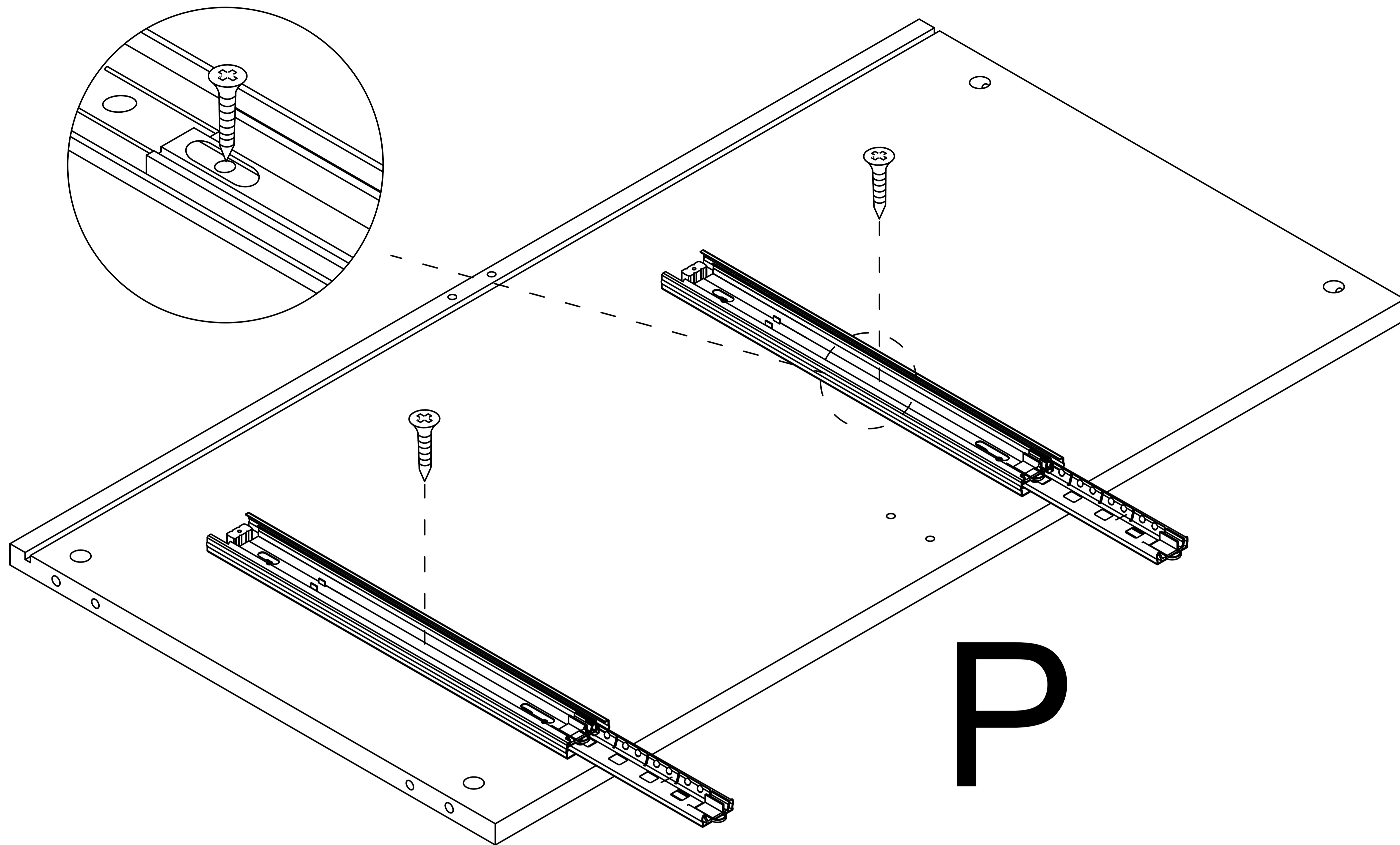
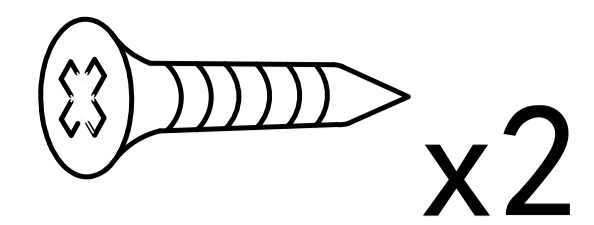

P

Step 33

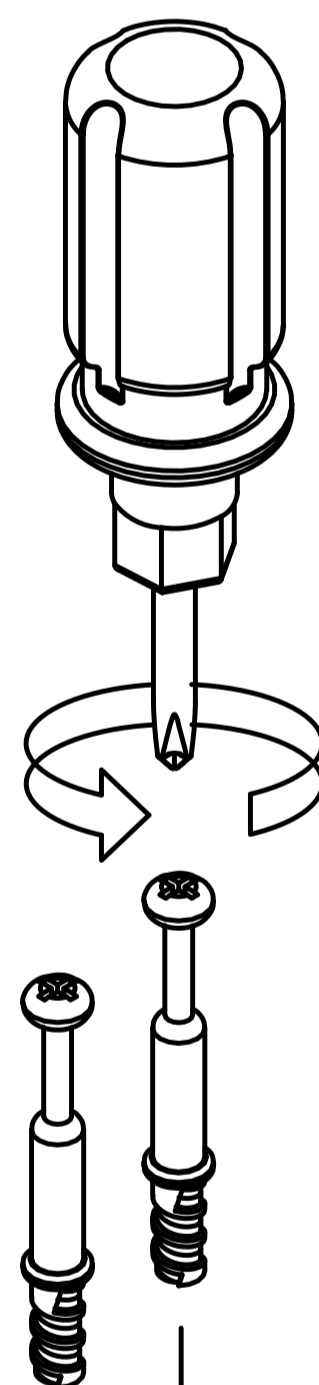

1

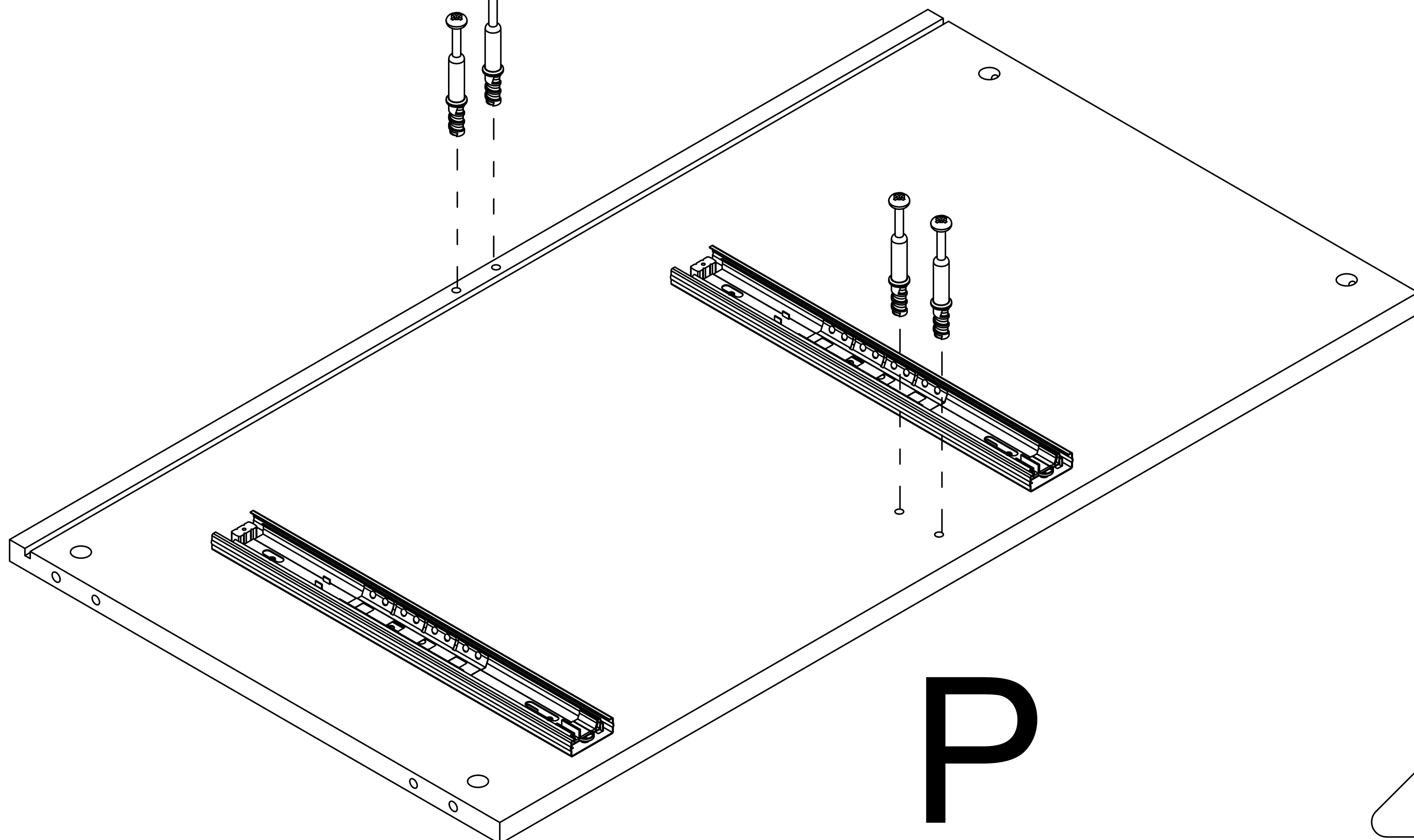
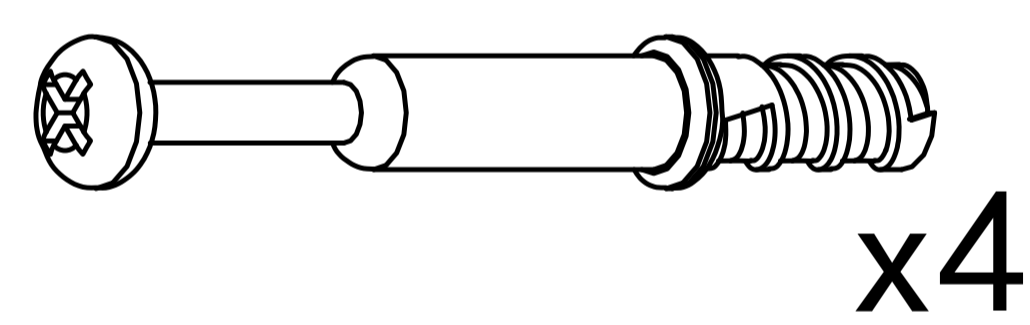

P

25

Step 34

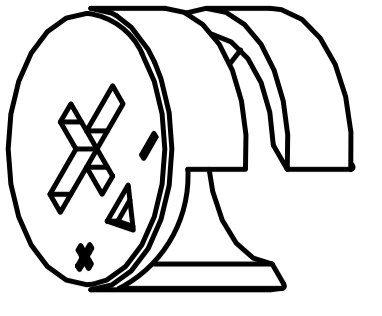
2  x4

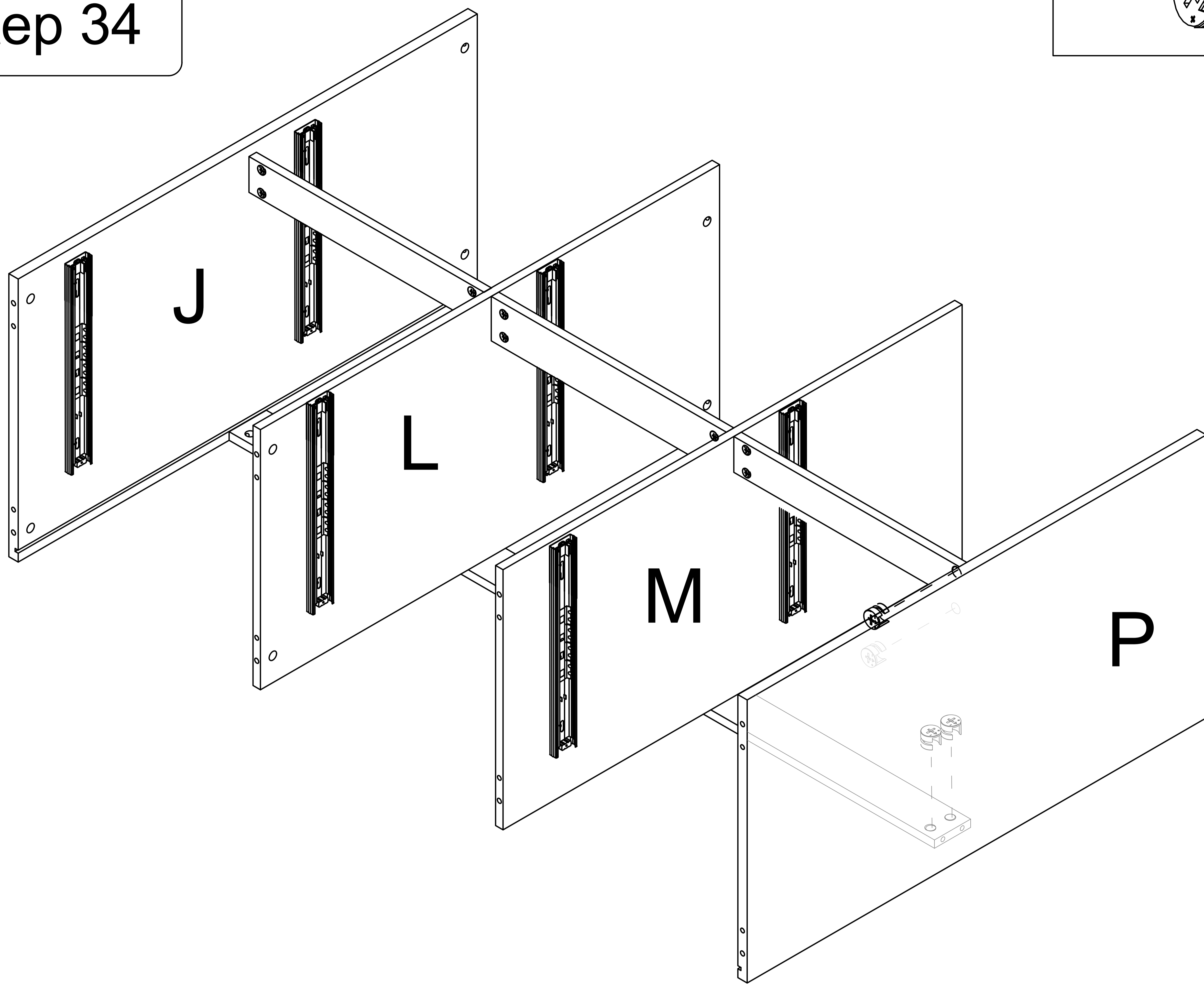

Step 35

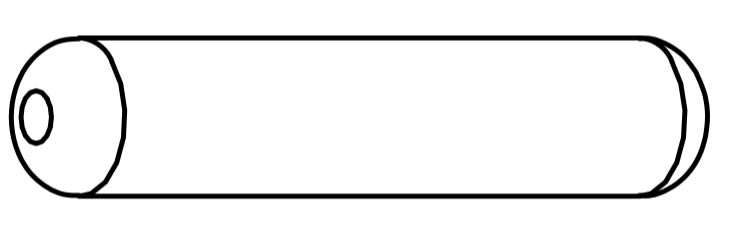
3  x8

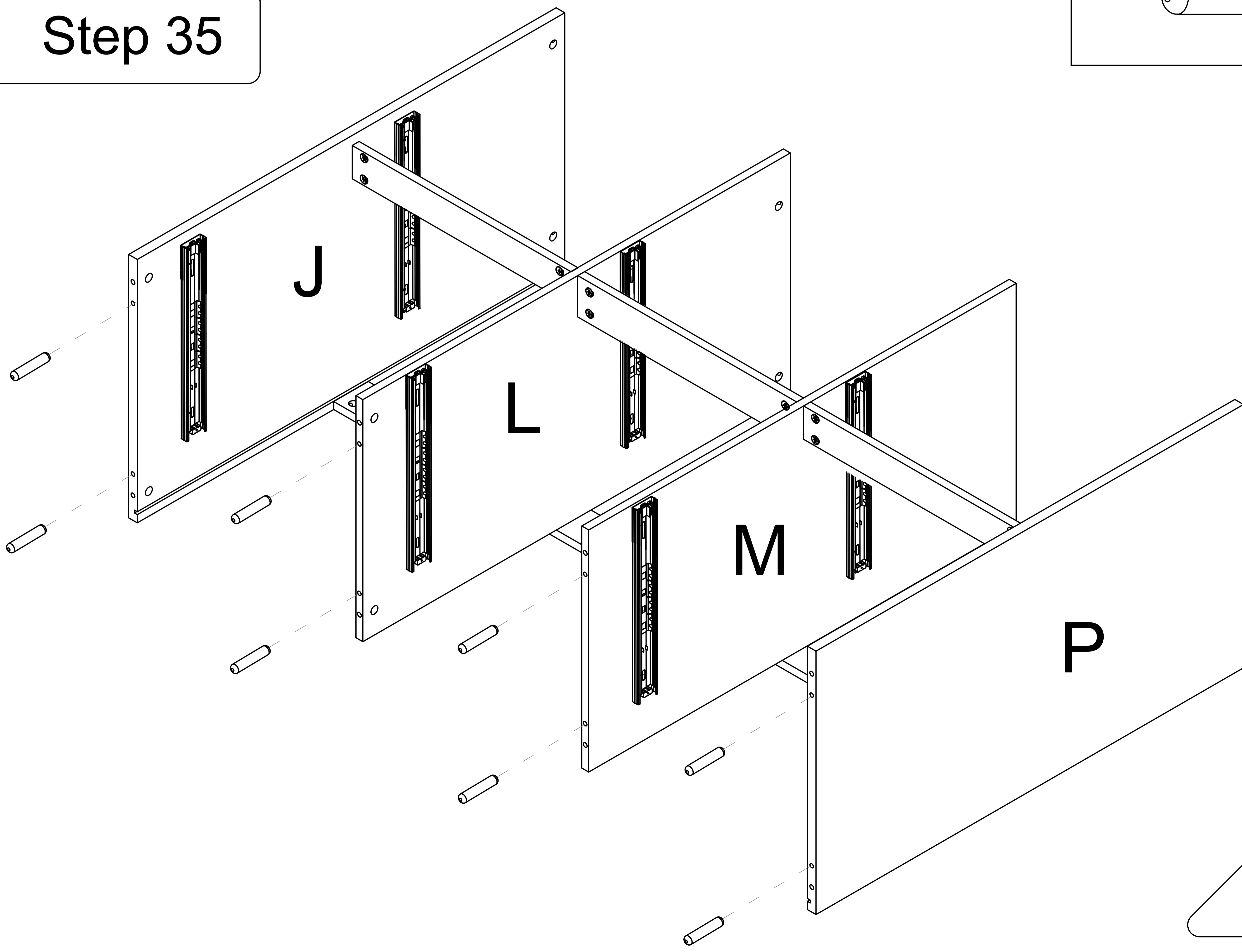

Step 36

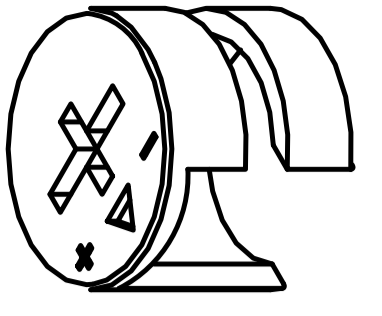
2  x8

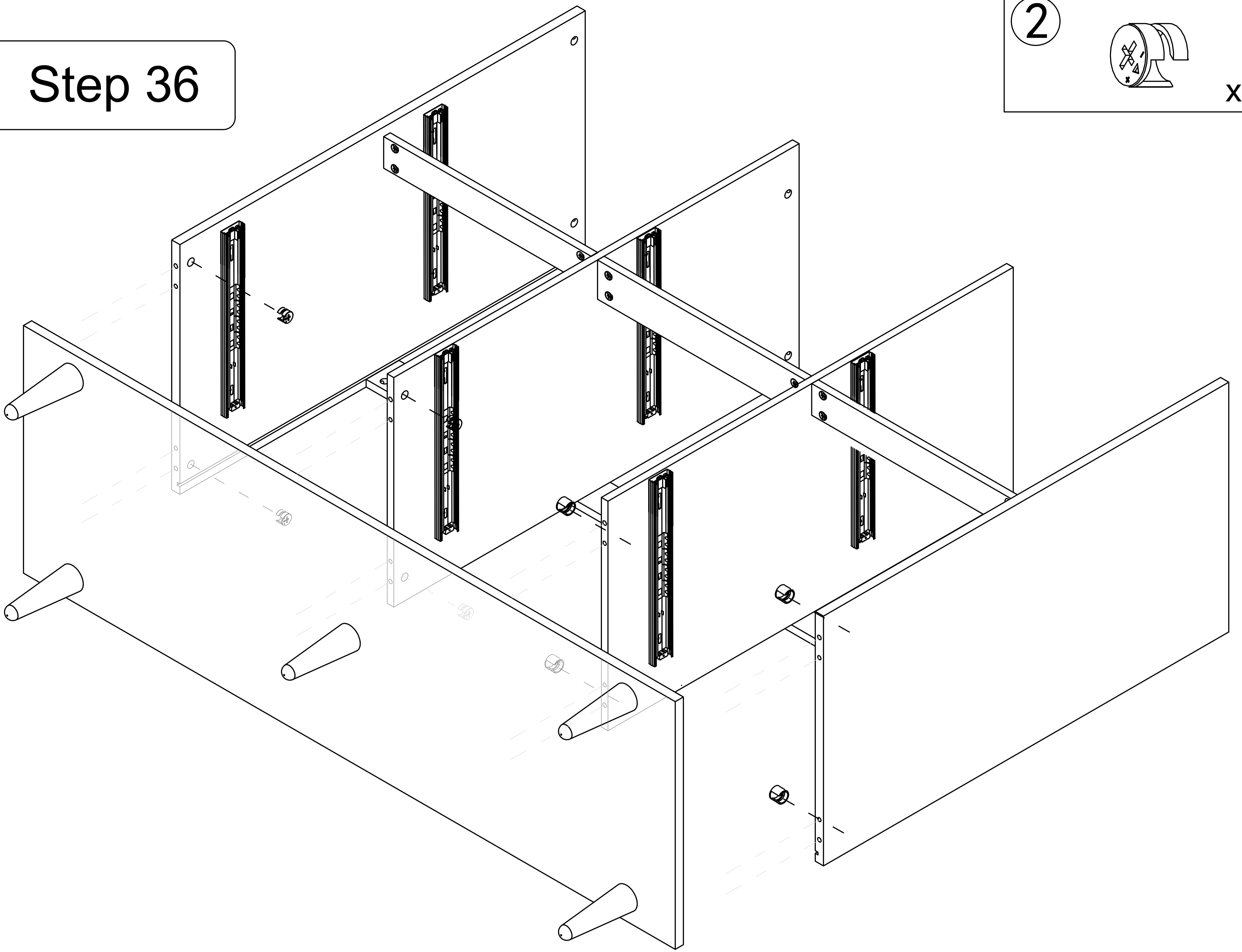

Step 37

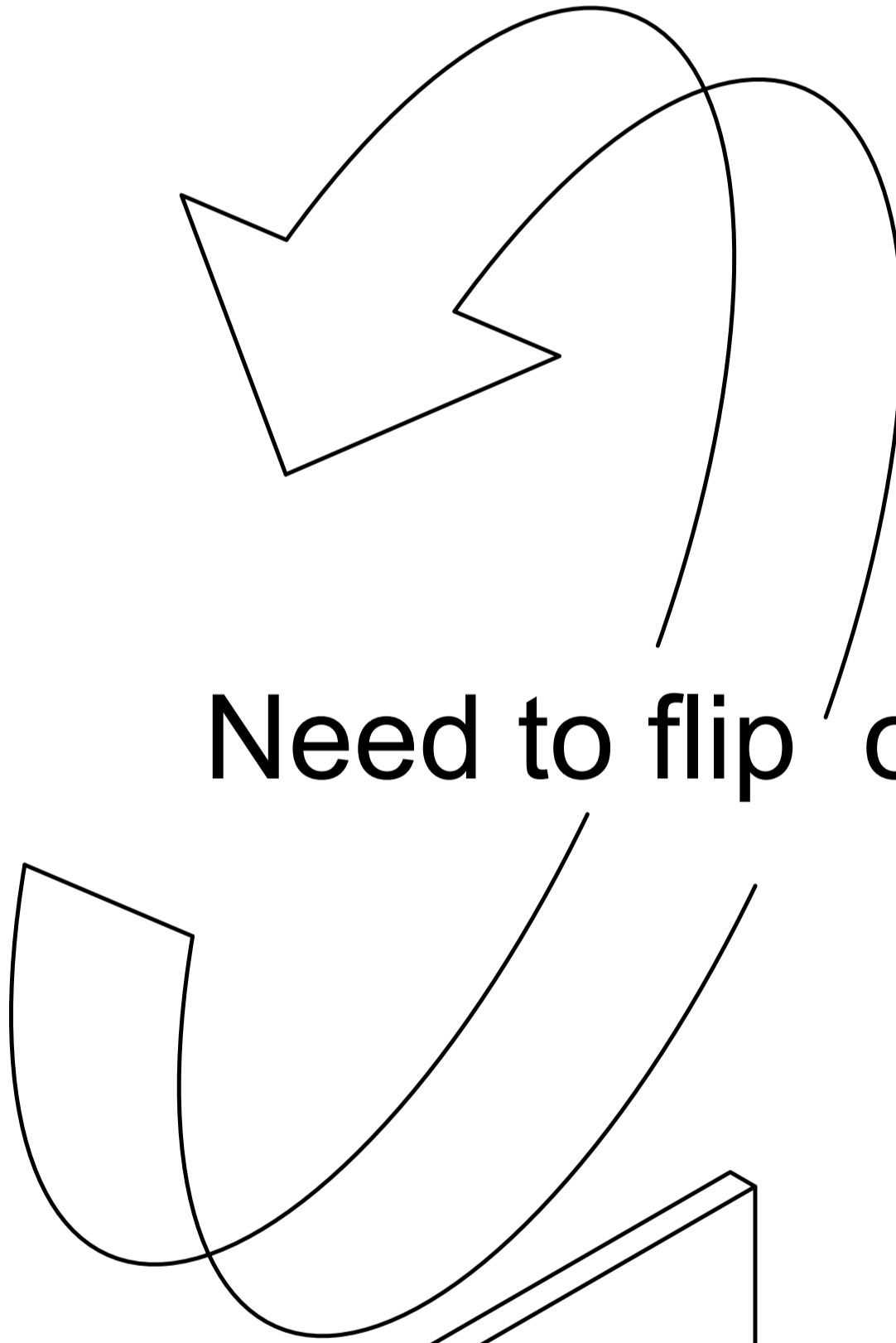
 Need to flip over

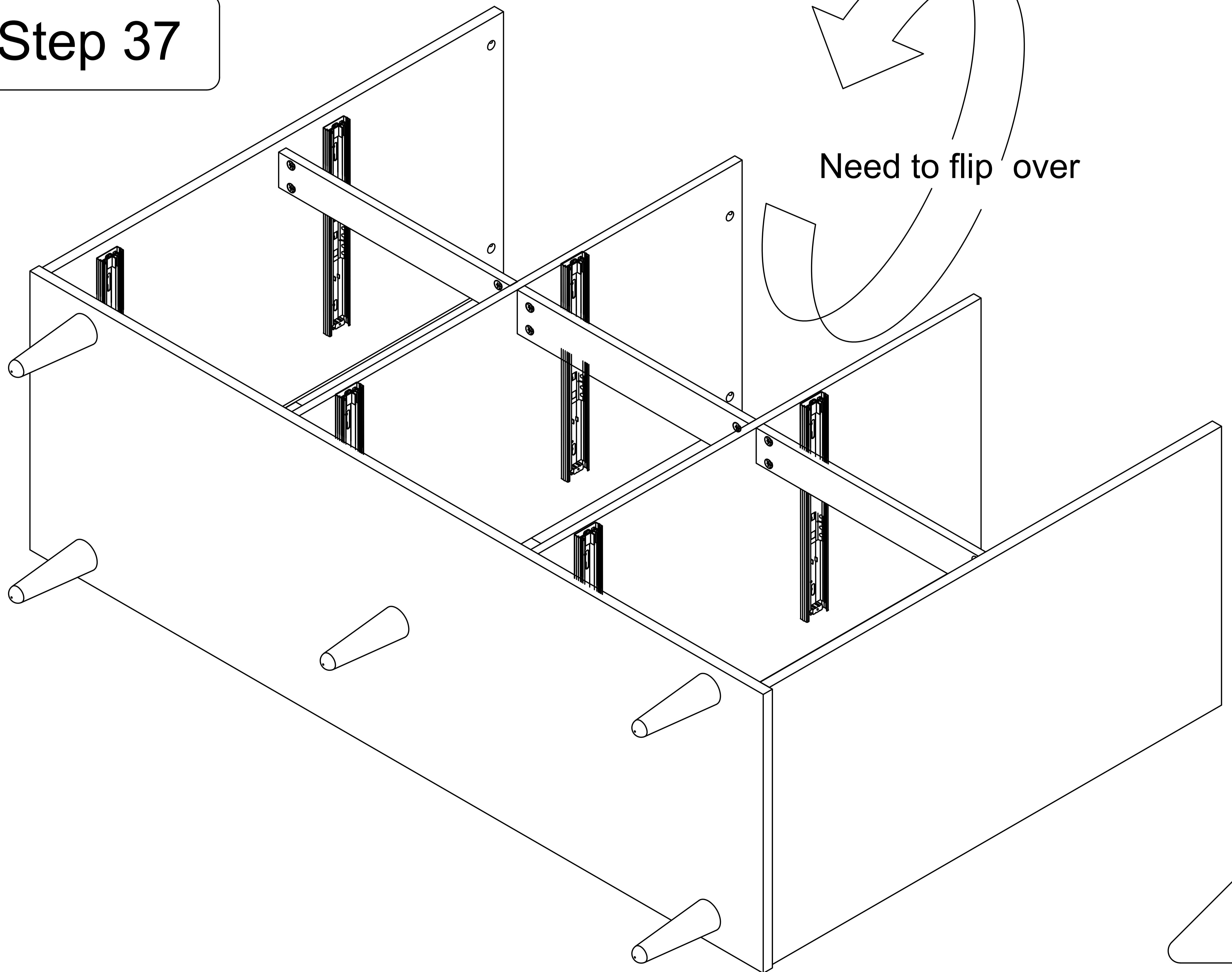

Step 38

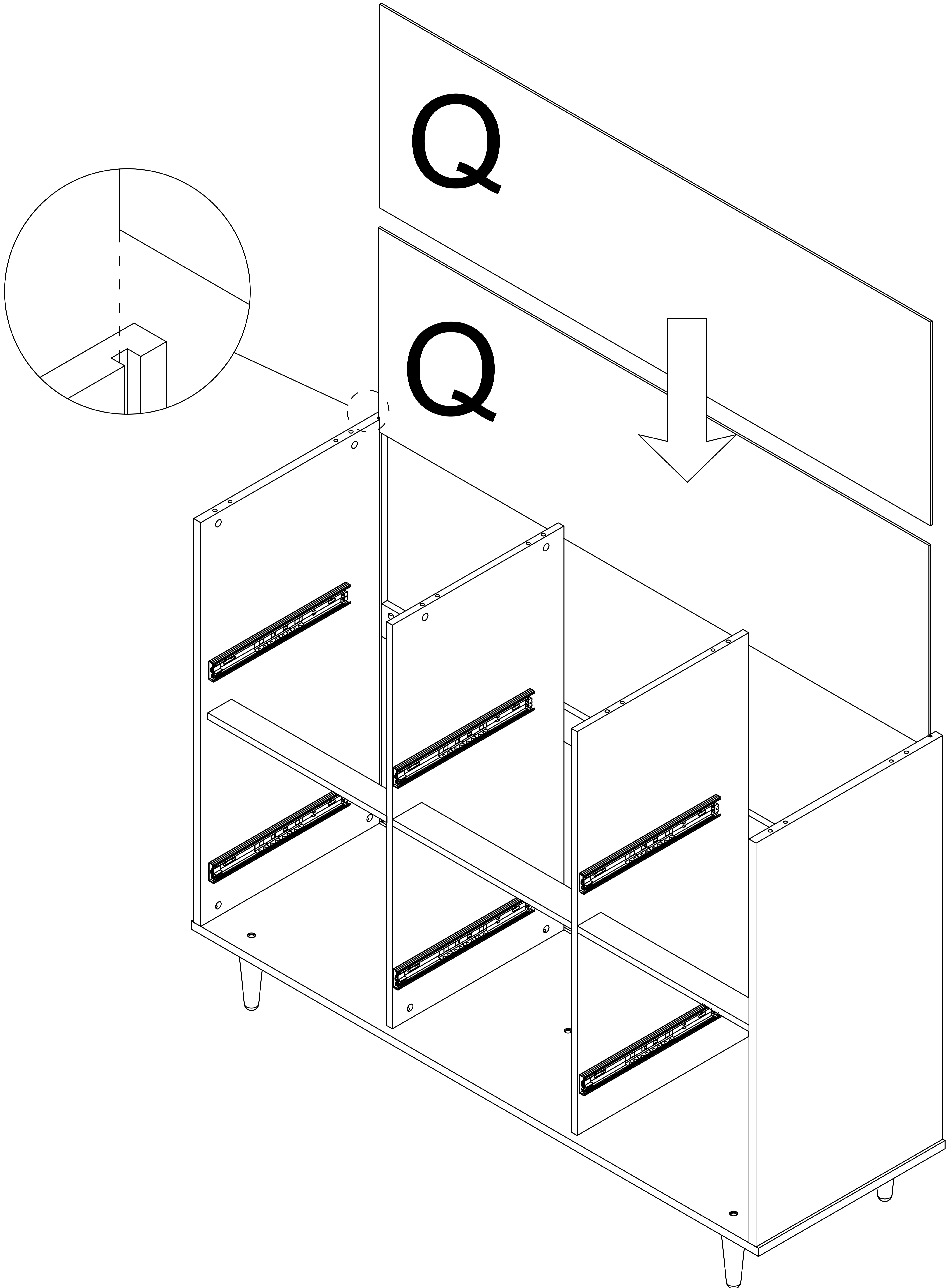

Step 39

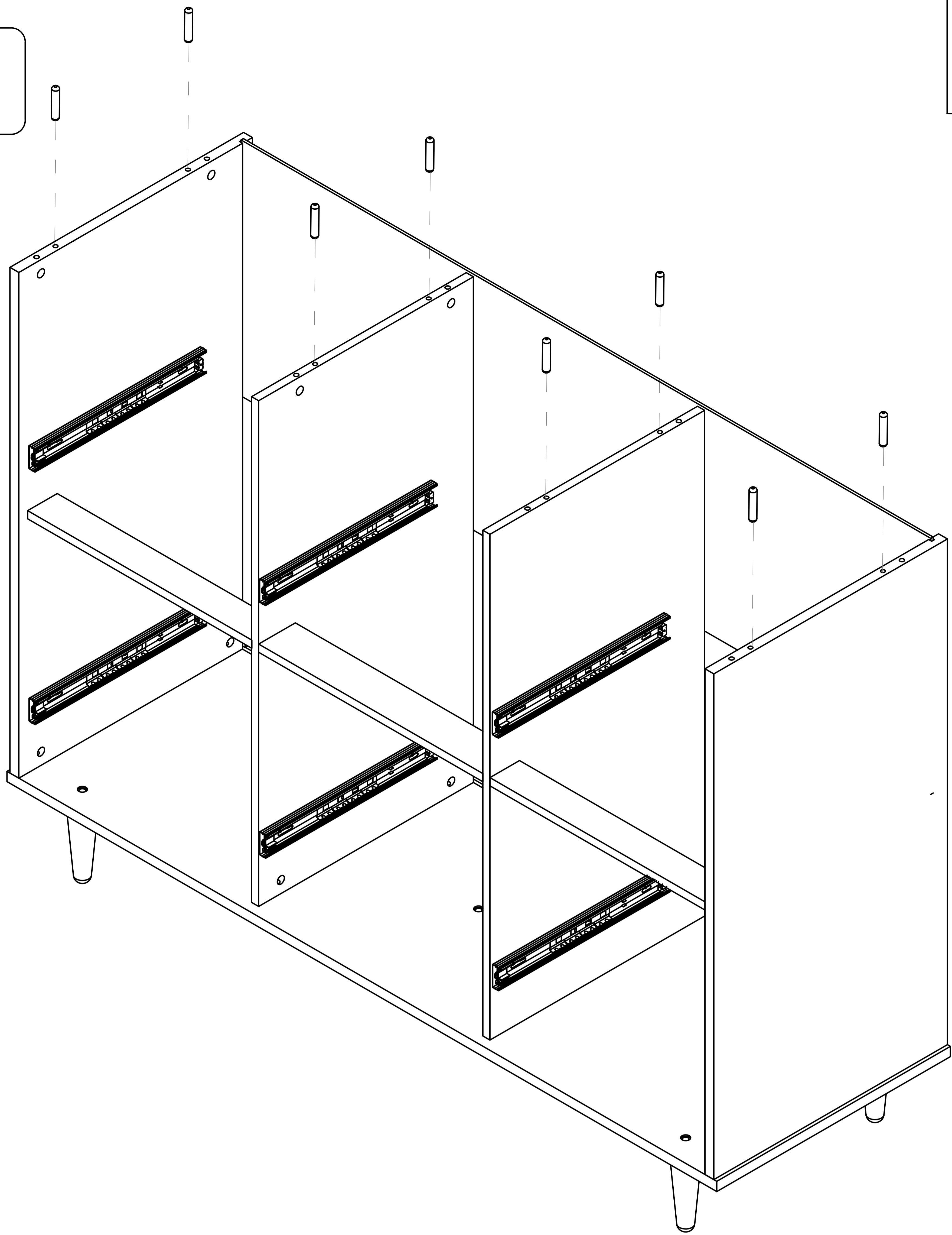
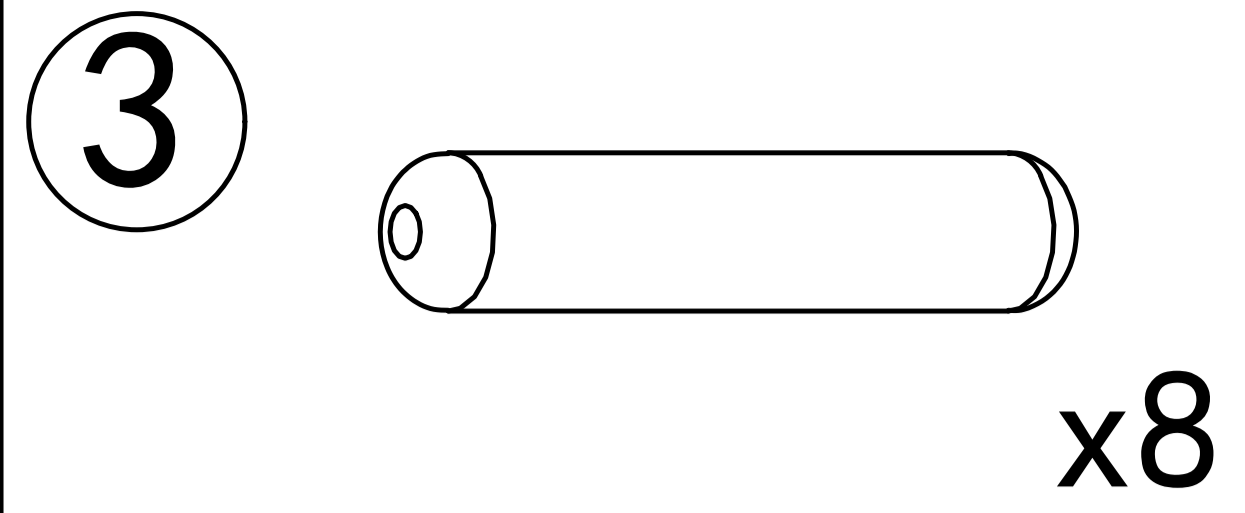

Step 40

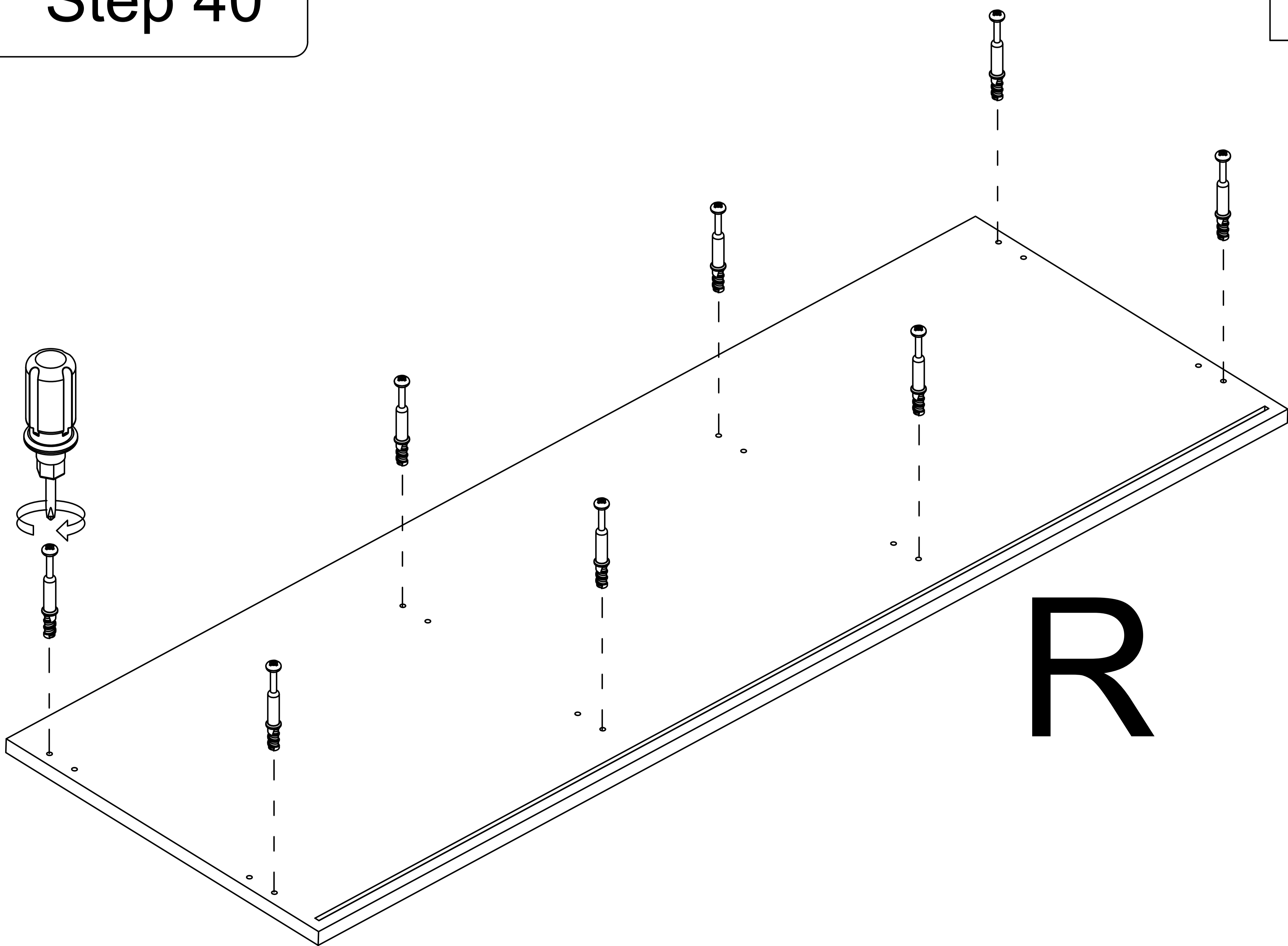
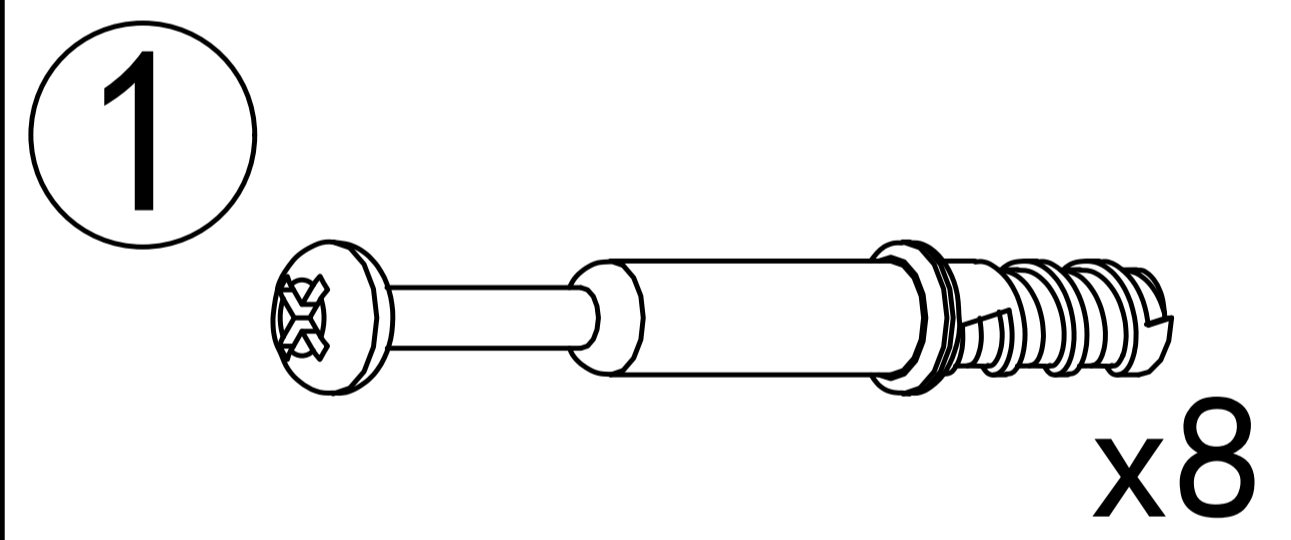

Step 41

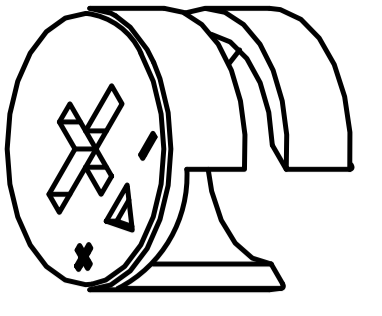
2  x8



Step 42

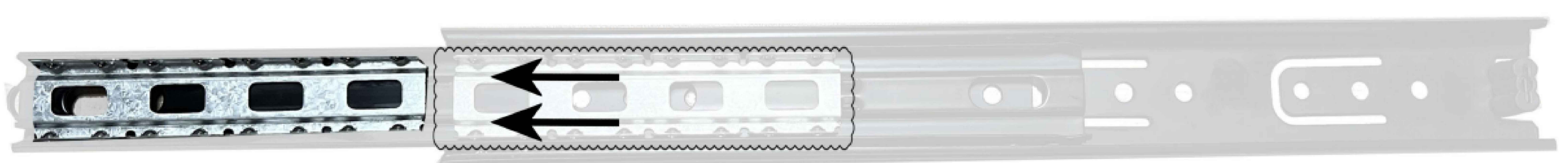
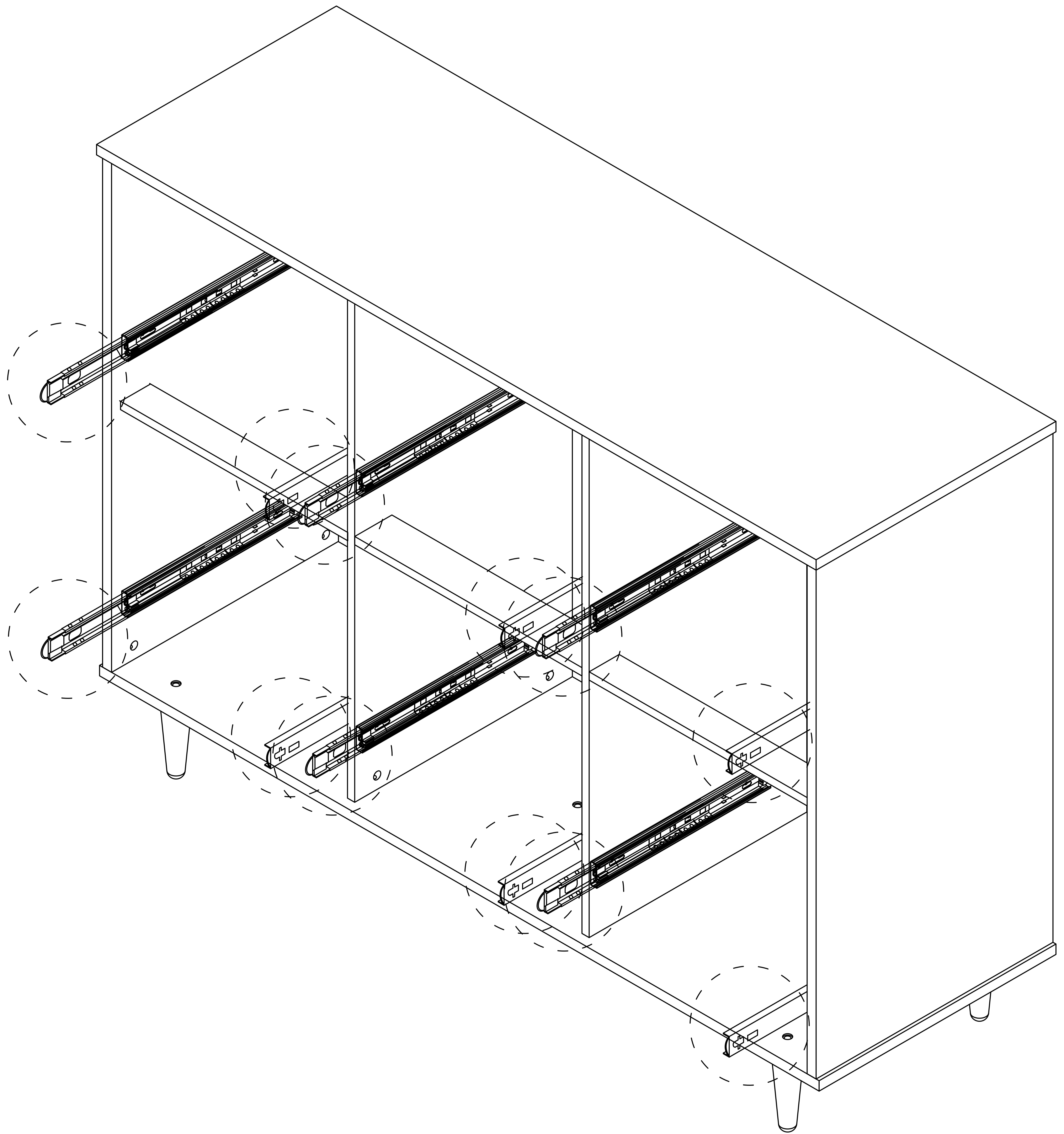

As shown, When installing the drawer,
pull the guide rail out first, Slide beads are also pulled out.

Step 43

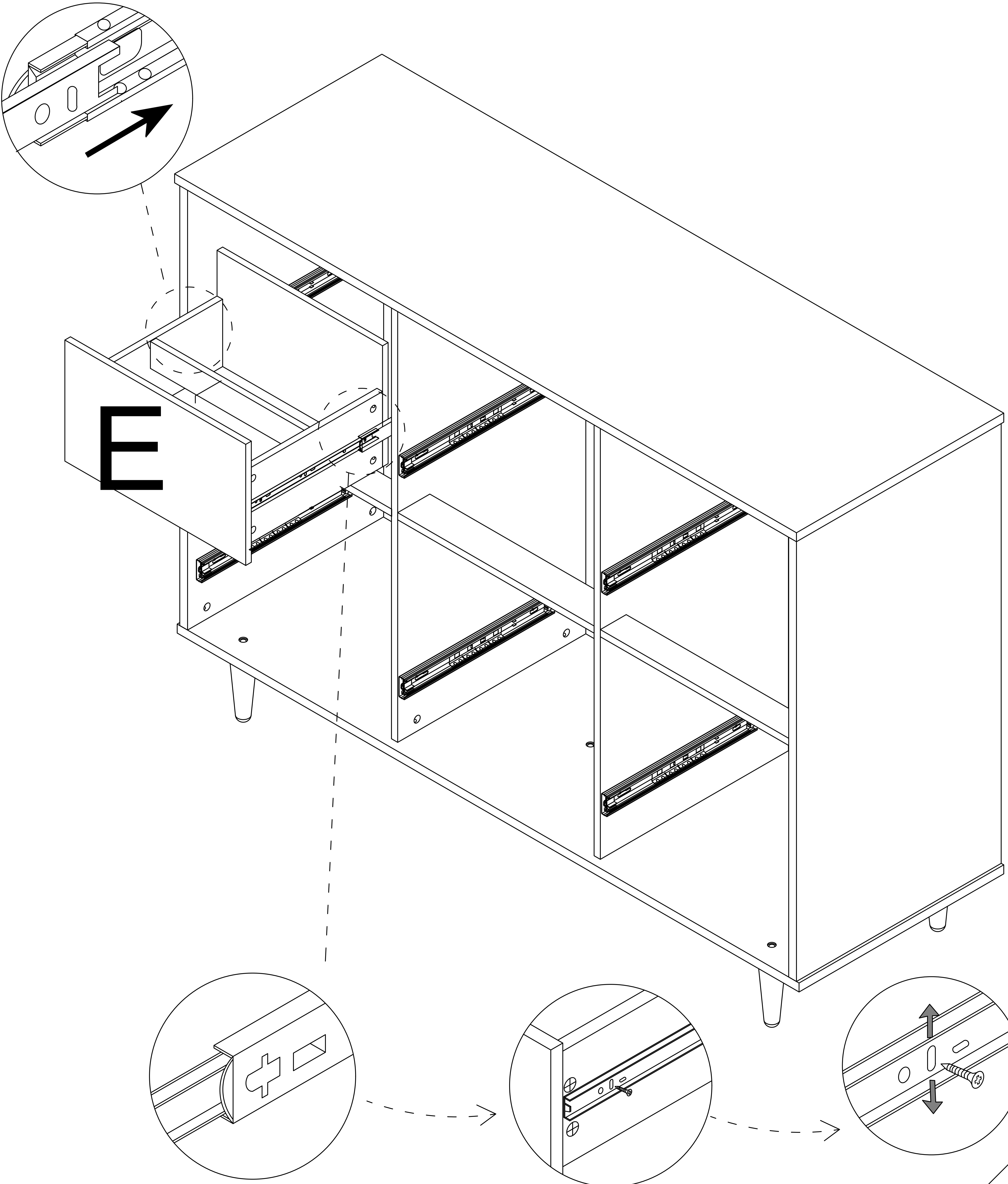

If a large gap is found after installing the drawer the slide rail can be moved up and down to adjust the gap

Step 44

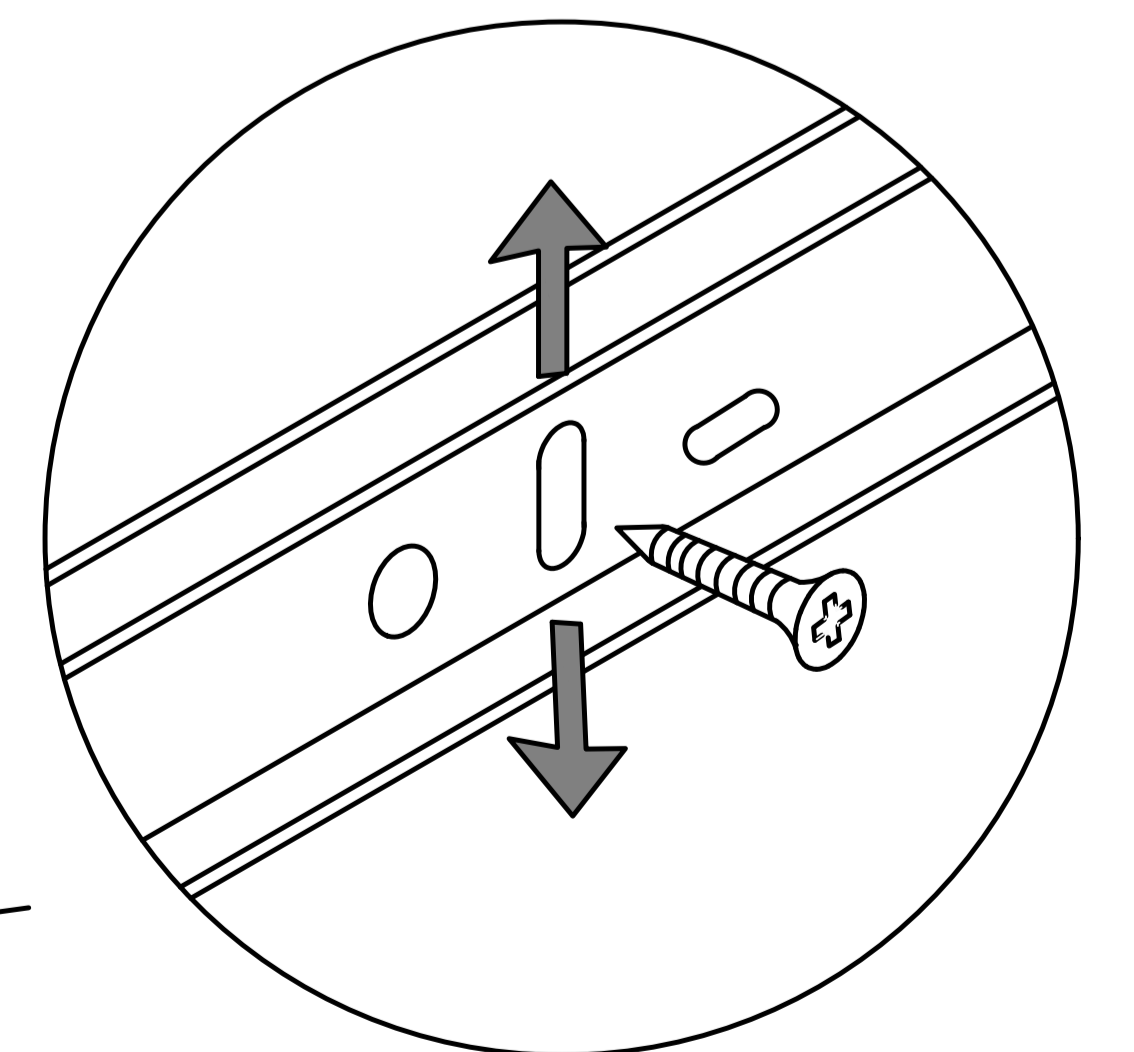
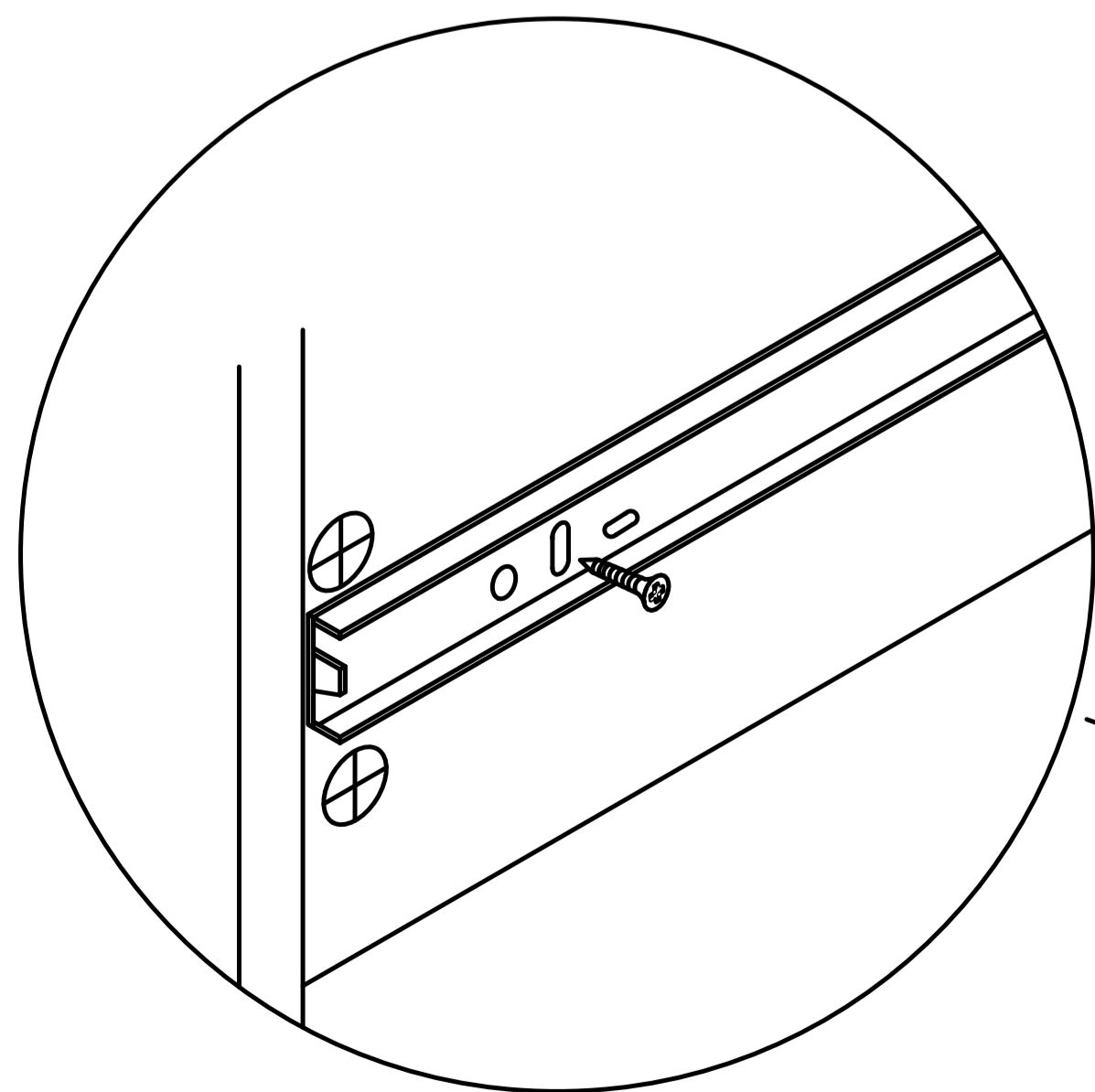
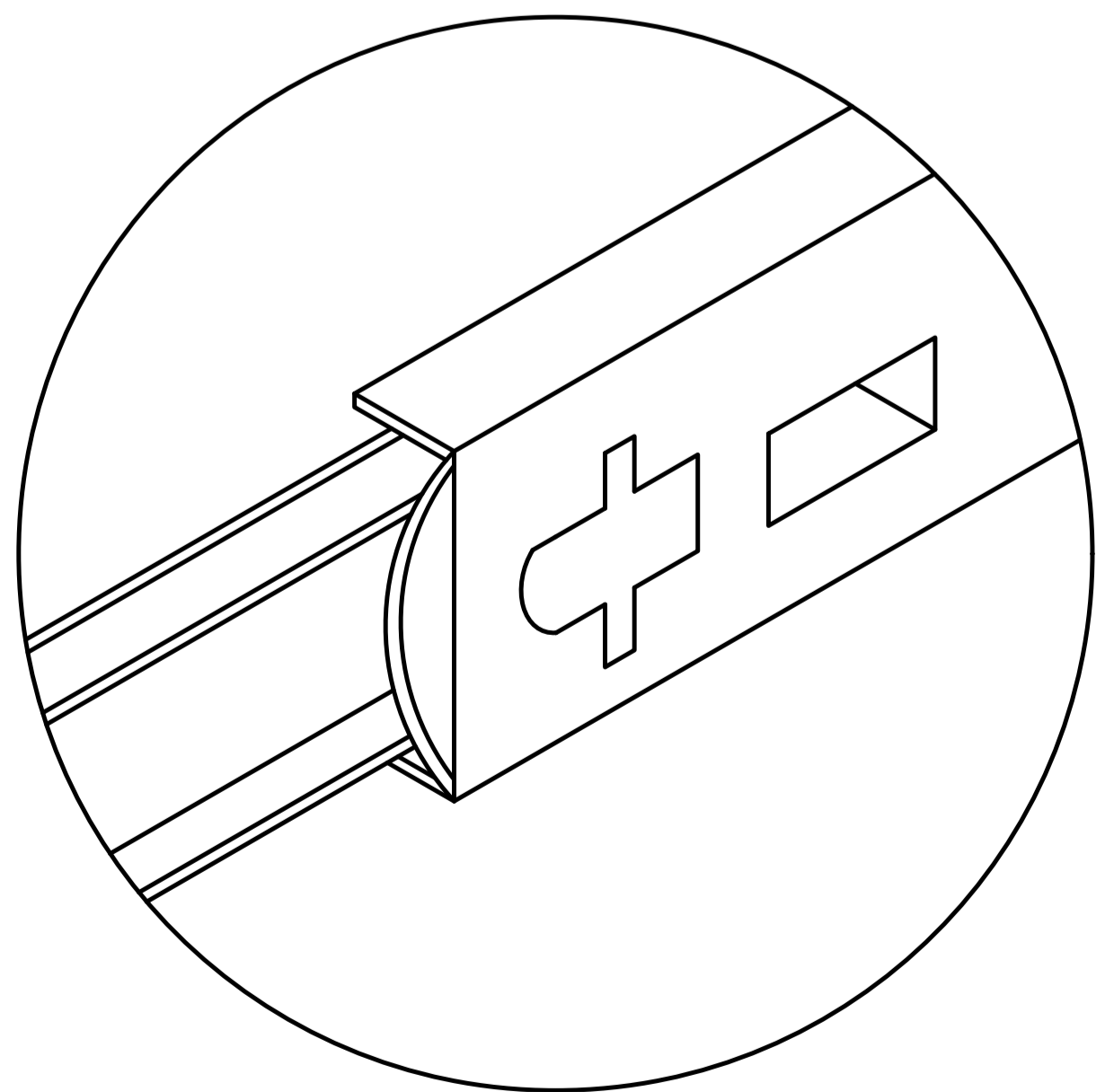
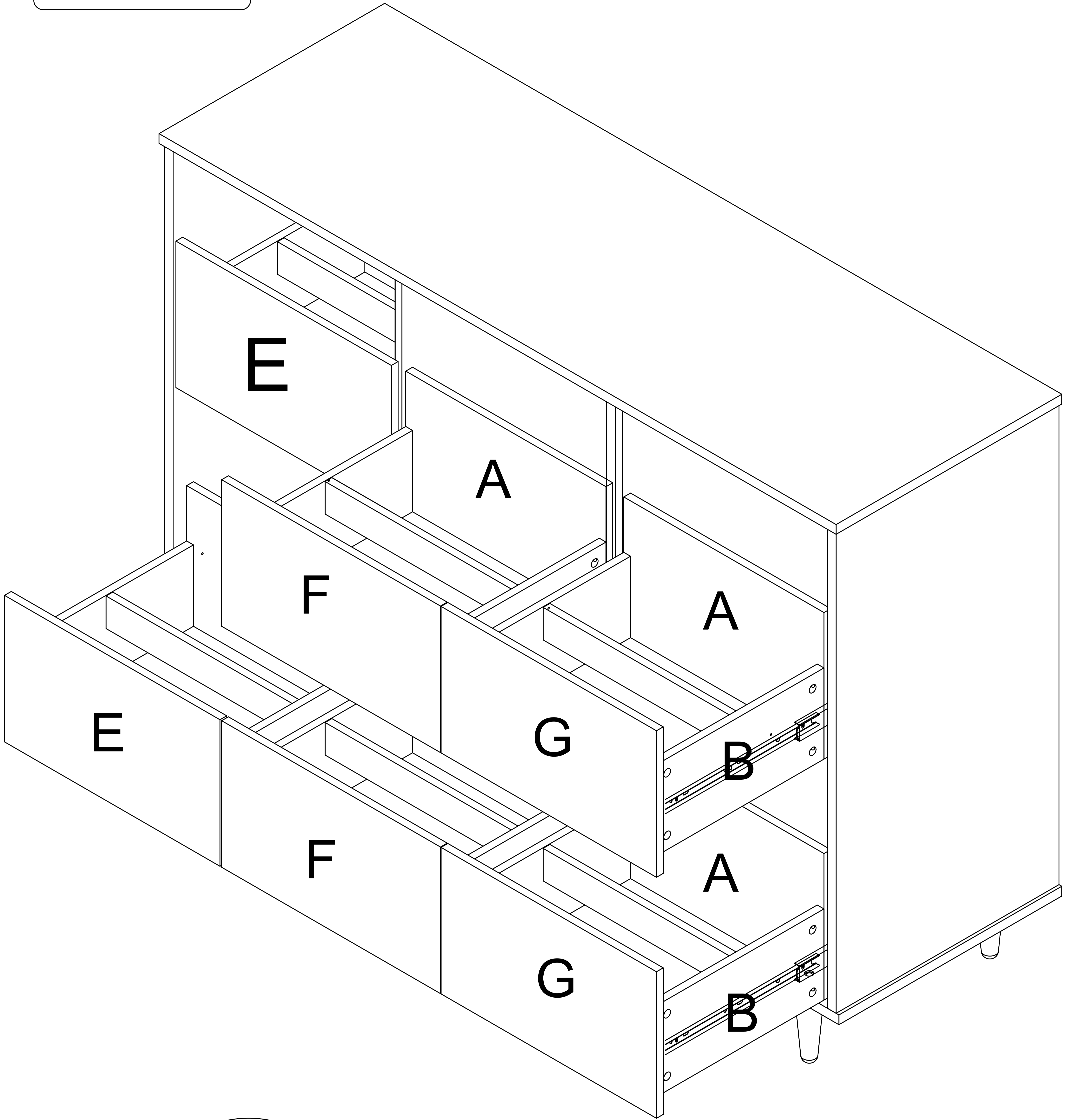

If a large gap is found after installing the drawer the slide rail can be moved up and down to adjust the gap

Step 45

6

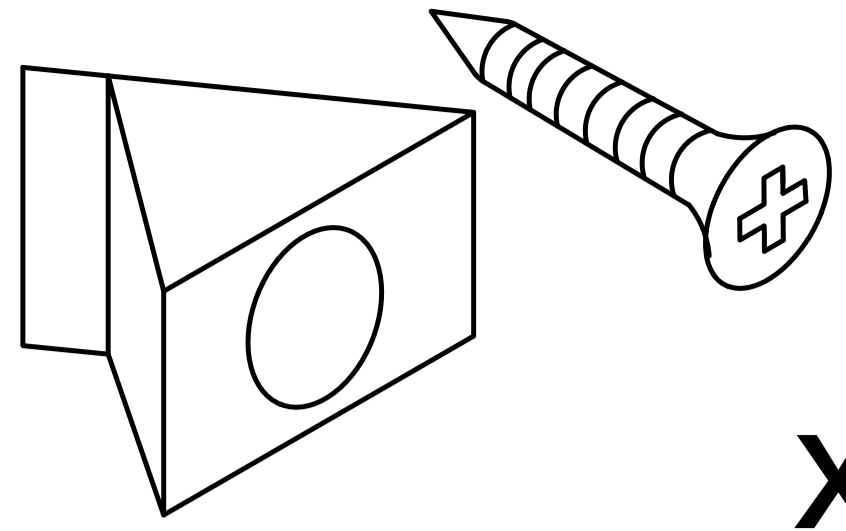

x12

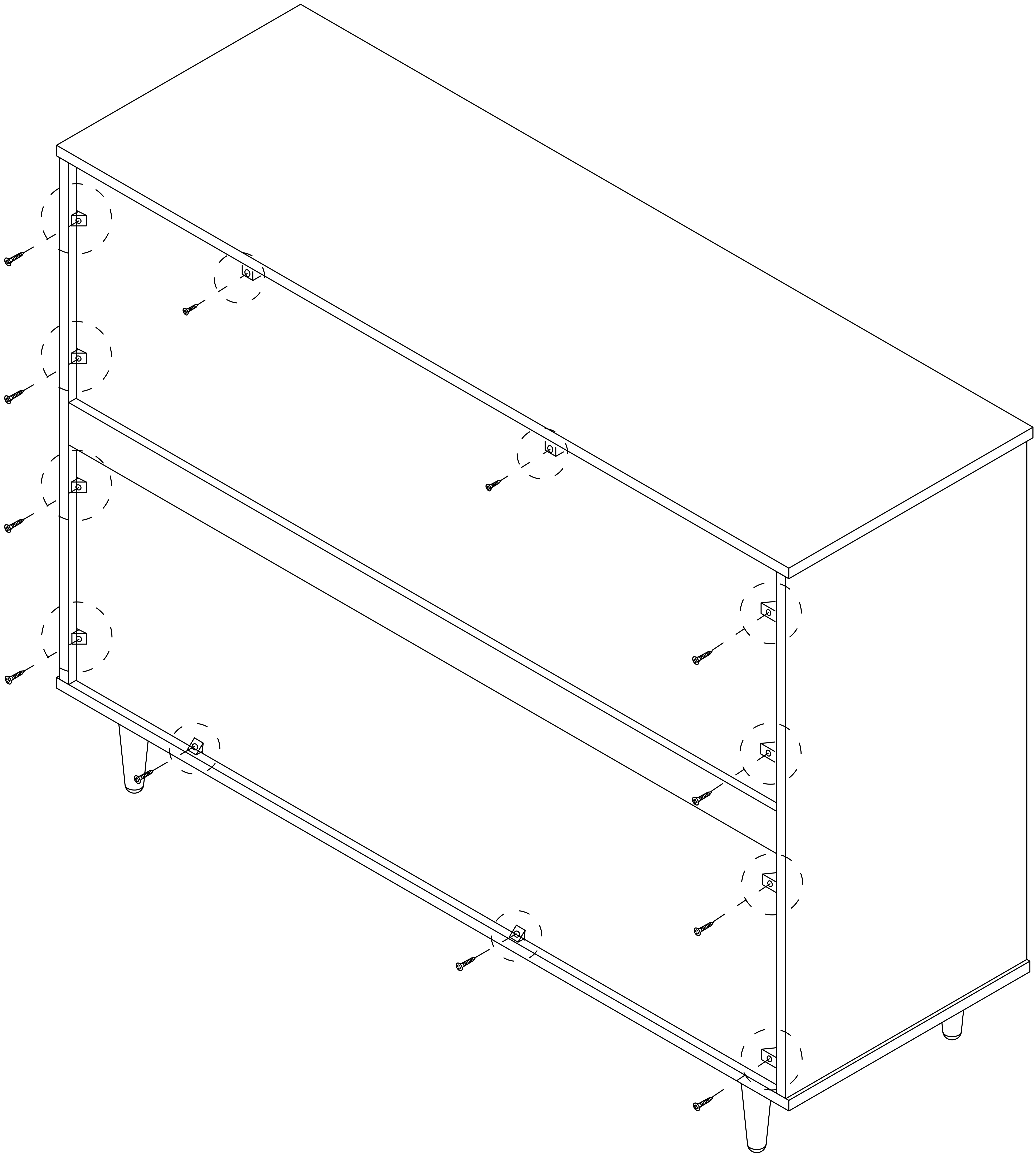

Step 46

7

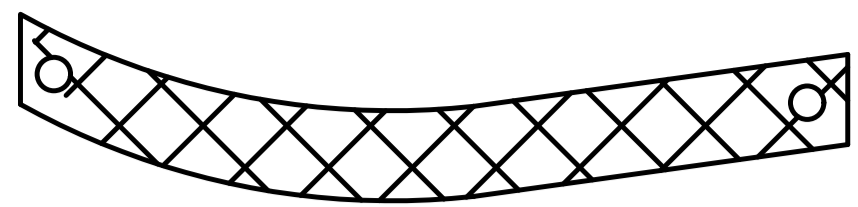

1 pcs

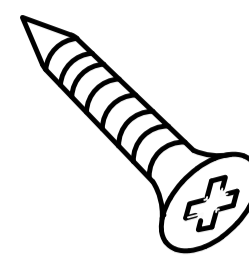

1 pcs

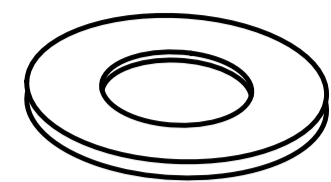

1 pcs

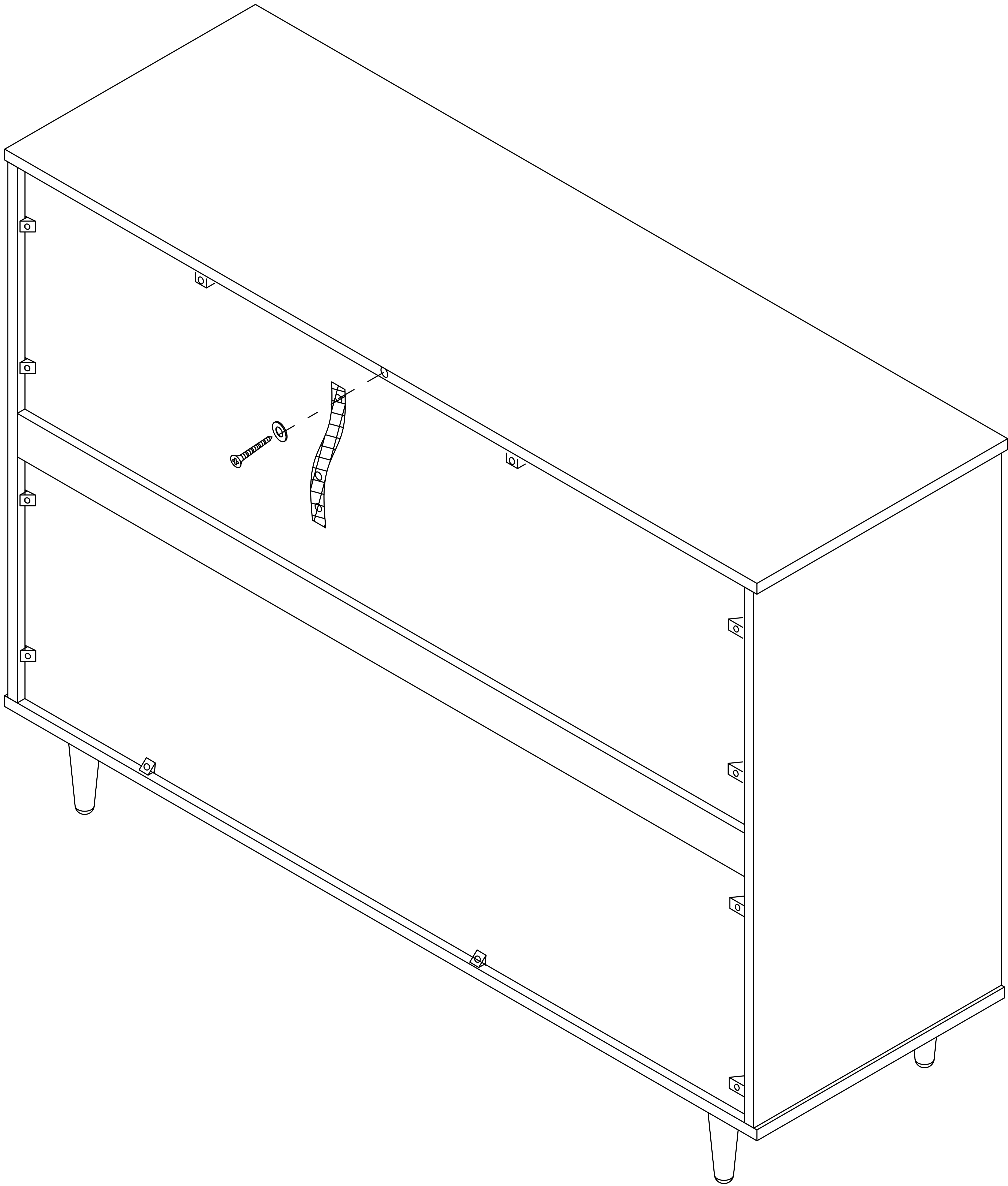

Step 47

use a ruler to measure the approximate height of the product on the wall, and then mark it with a pencil.

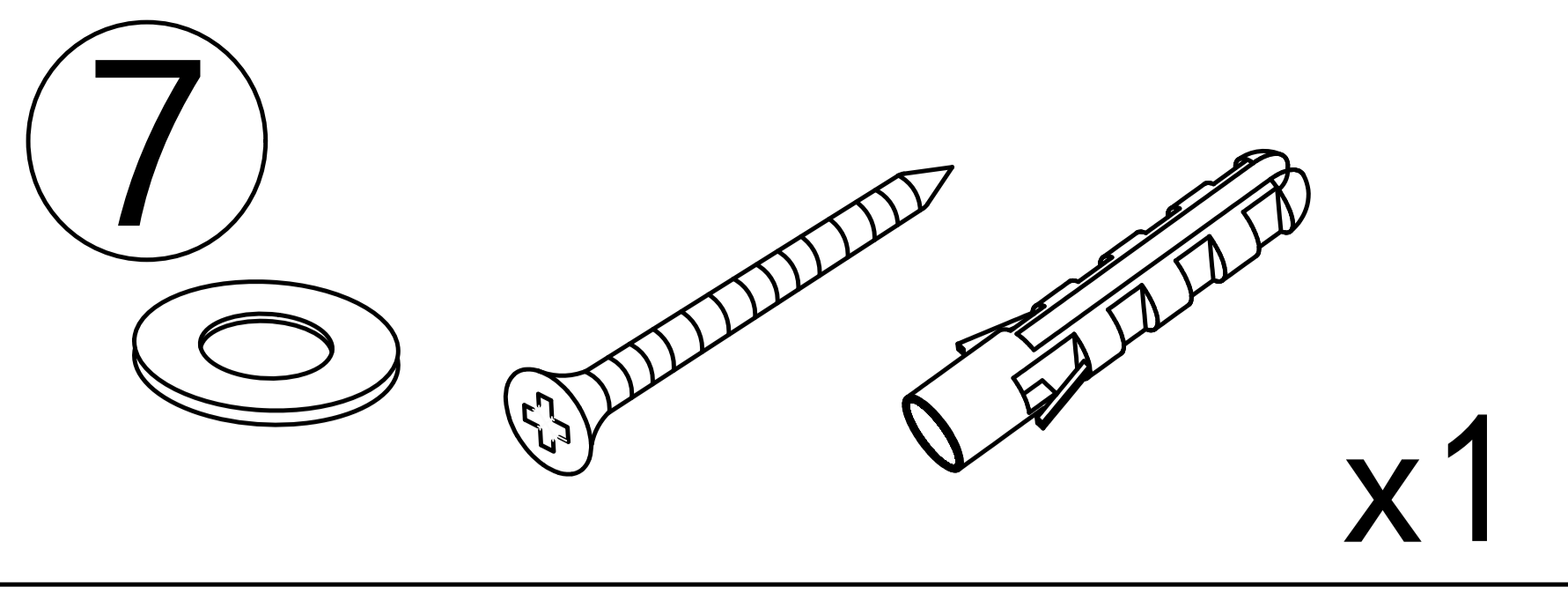
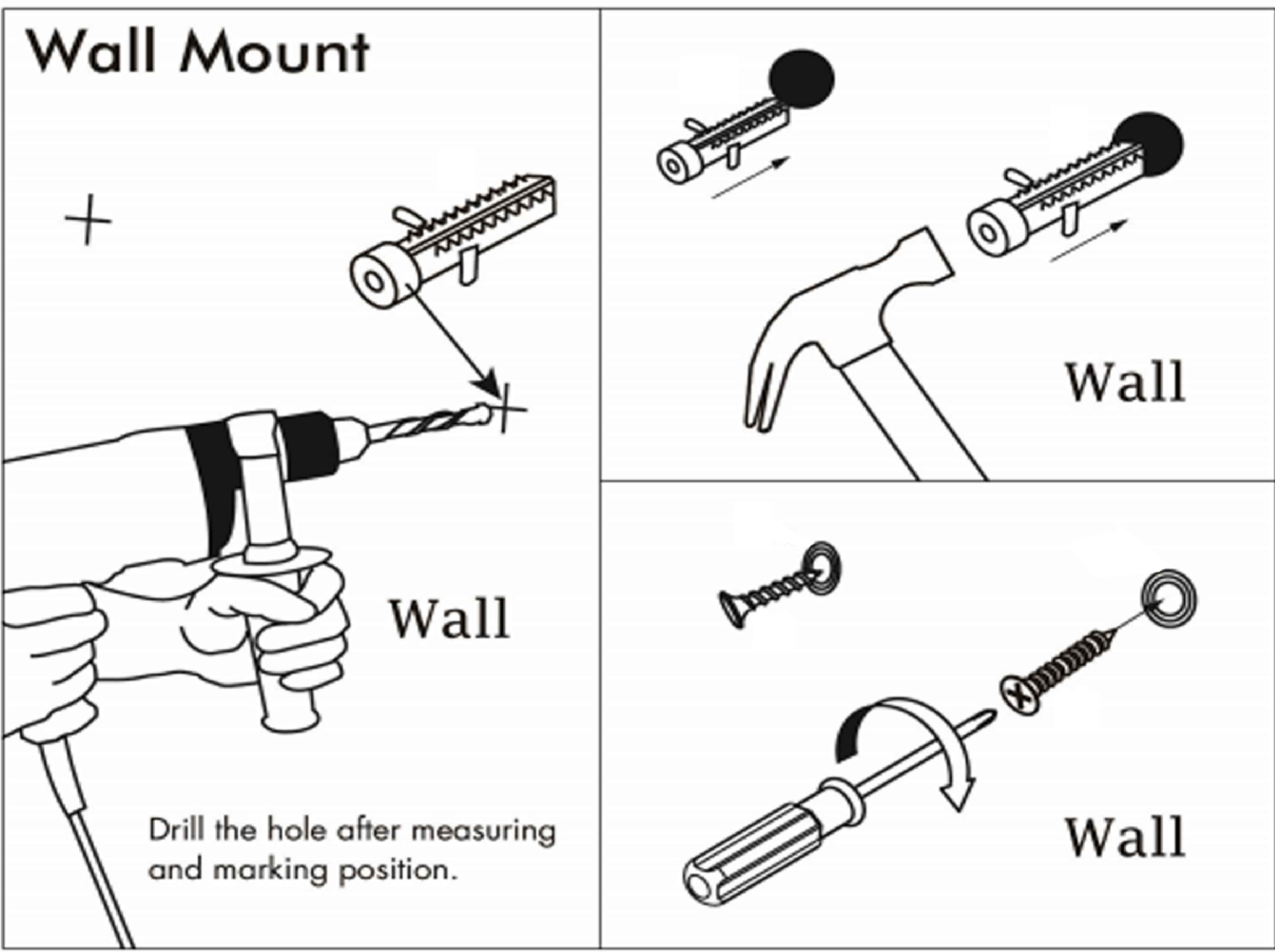

Put the expansion bolt into the hole.

Pass the matching screws through the "anti-rewind" and tighten them to fix them on the wall.

Use a tape drill to make holes in the wall that are suitable for the product screws.

