

# Installation Instruction

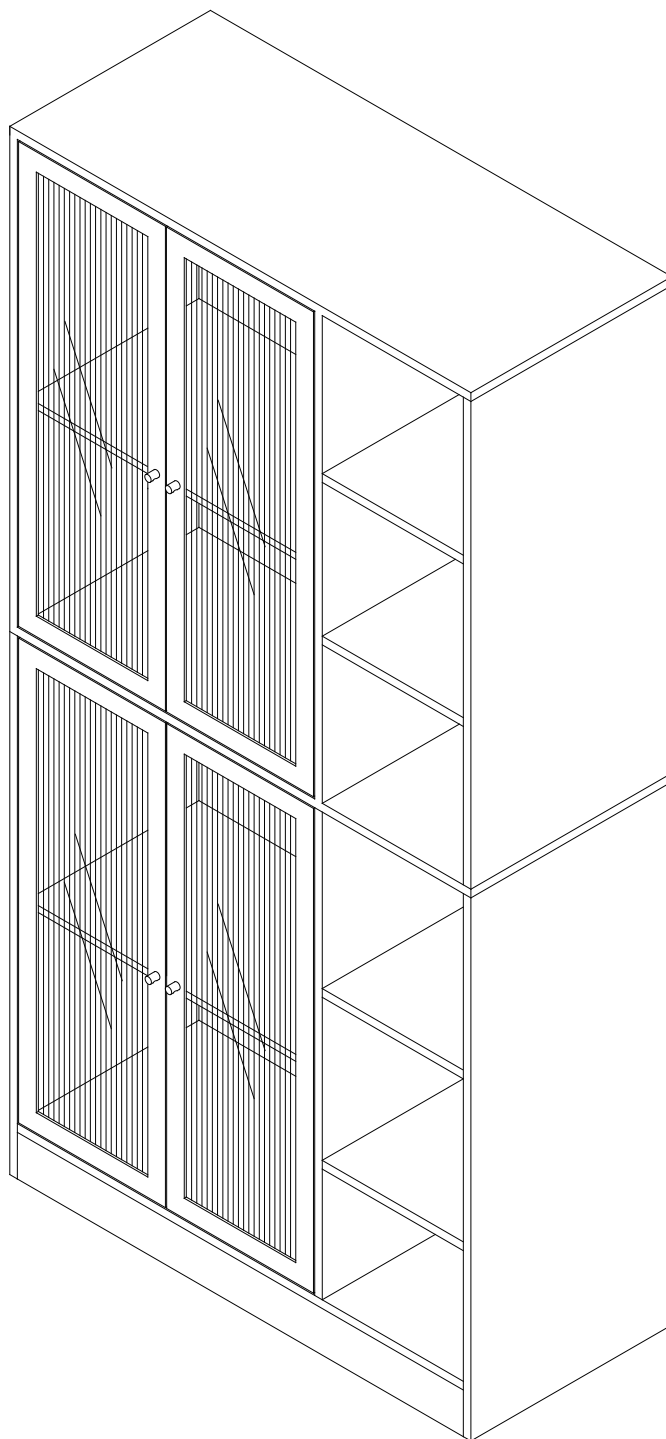

# Assembling

Estimated time for assembly



**45 : 00**

## What you need

- Use the packaging carton as a working surface to prevent product damage during assembly
- Phillips head screwdriver

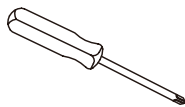

## Weight Limitation



**50** | **20**

lbs table top | lbs per shelf



**2 PERSONS**

# What 's included

Code	Description	Qty
A	Cam Bolt M6X35MM	29
B	Cam Lock 15X10MM	29
C	Wooden Dowel M6X30MM	26
D	Screw M4X40MM	10
E	Screw M3X14MM	16
F	Magnetic Door Catcher	4
G	Handle	4
H	Bolt M4X20MM	4
I	Meral Support	24
J	Metal Pin	8
K	Metal Plate	8
L	Screw M4X12MM	2
M	Lock Wall Metal	2
N	Anchor M6	2
O	Screw M4X14MM	8
P	Plastic Corner Support	8
Q	Screw M3X16MM	8

# The hardwares

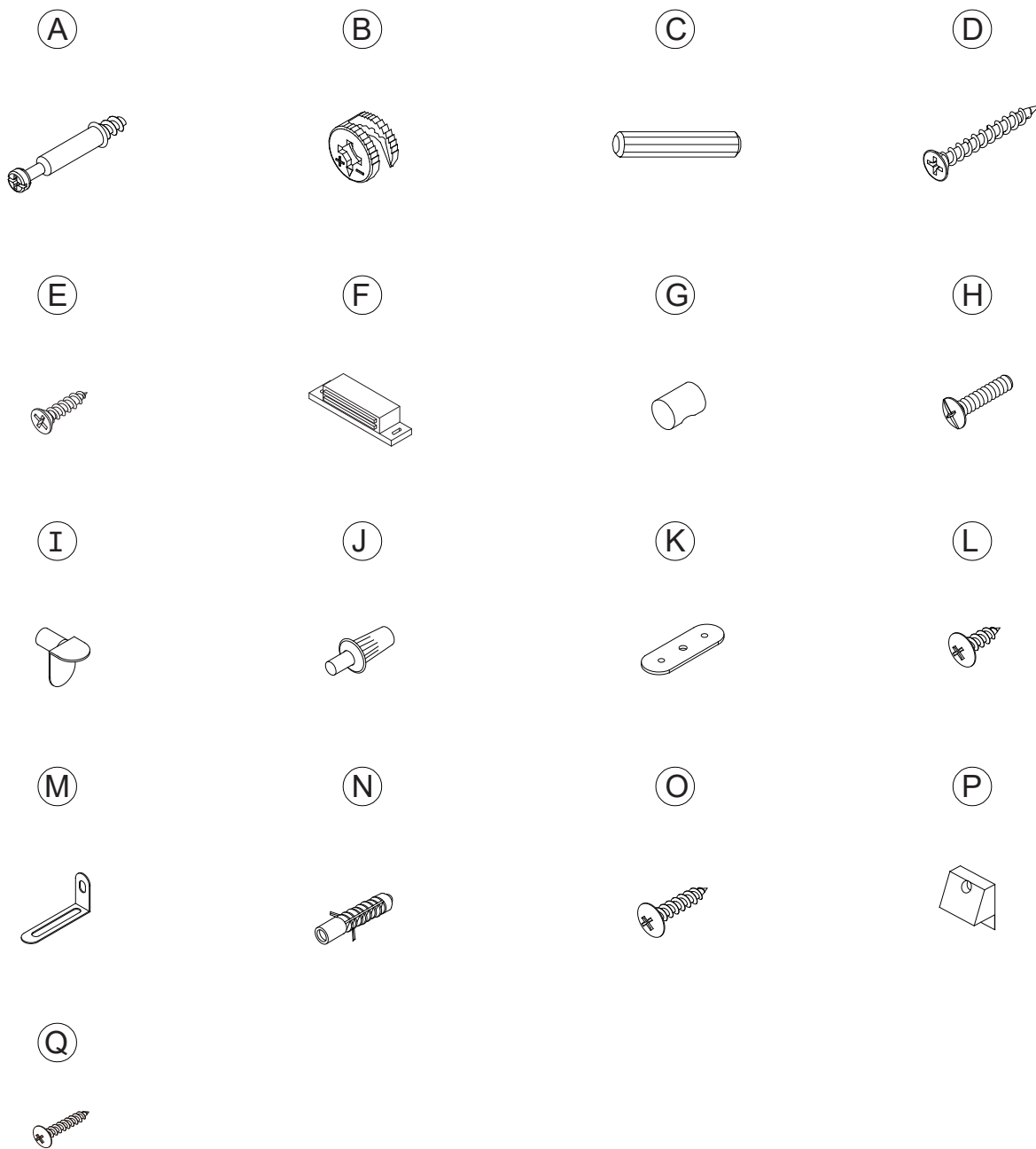

## IMPORTANT :

1. Do not tighten bolts / screws completely until all bolts / screws are lined up and inserted into holes.
2. Do not over tighten screws and bolts to avoid stripping.
3. Please use hand tools to assemble this product. Do not use power tools.
4. Must need 2 people to assemble this product.



2 PERSONS

# Included Accessories

Code	Description	Qty
1	Cabinet Top	1
2	Middle Panel	1
3	Bottom Panel	1
4	Left Side Panel	1
5	Middle Side Panel	1
6	Right Side Panel	1
7	Left Side Panel	1
8	Middle Back Panel	2
9	Right Side Panel	1
10	Back Strecher	2
11	Bottom Decorative Panel	1
12	Shelf	2
13	Shelf	4
14	Door	4
15	Plastic Strip	4
16	Top/Bottom Back Panel	4
17	Middle Side Panel	1



**NOTED:**

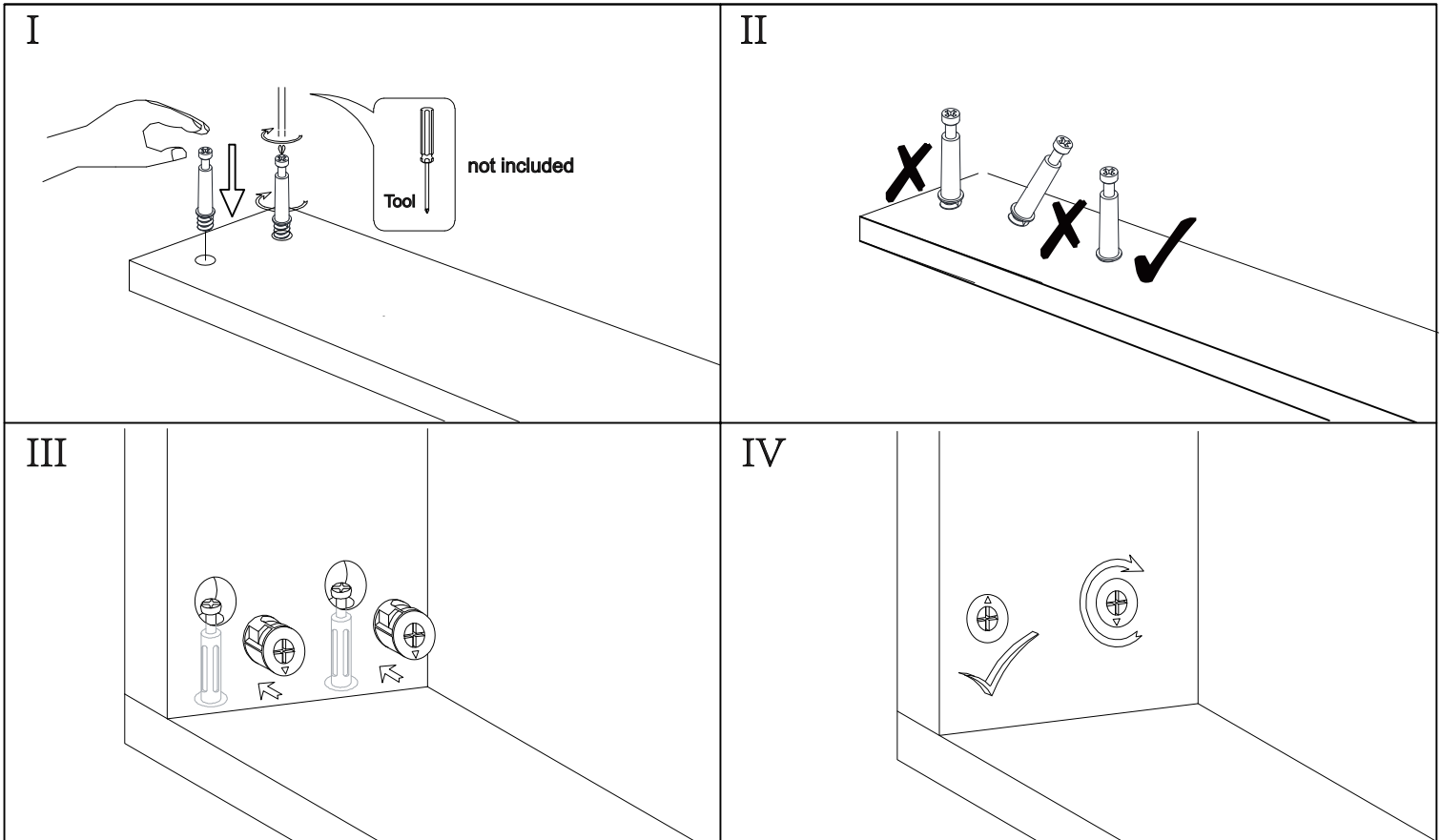

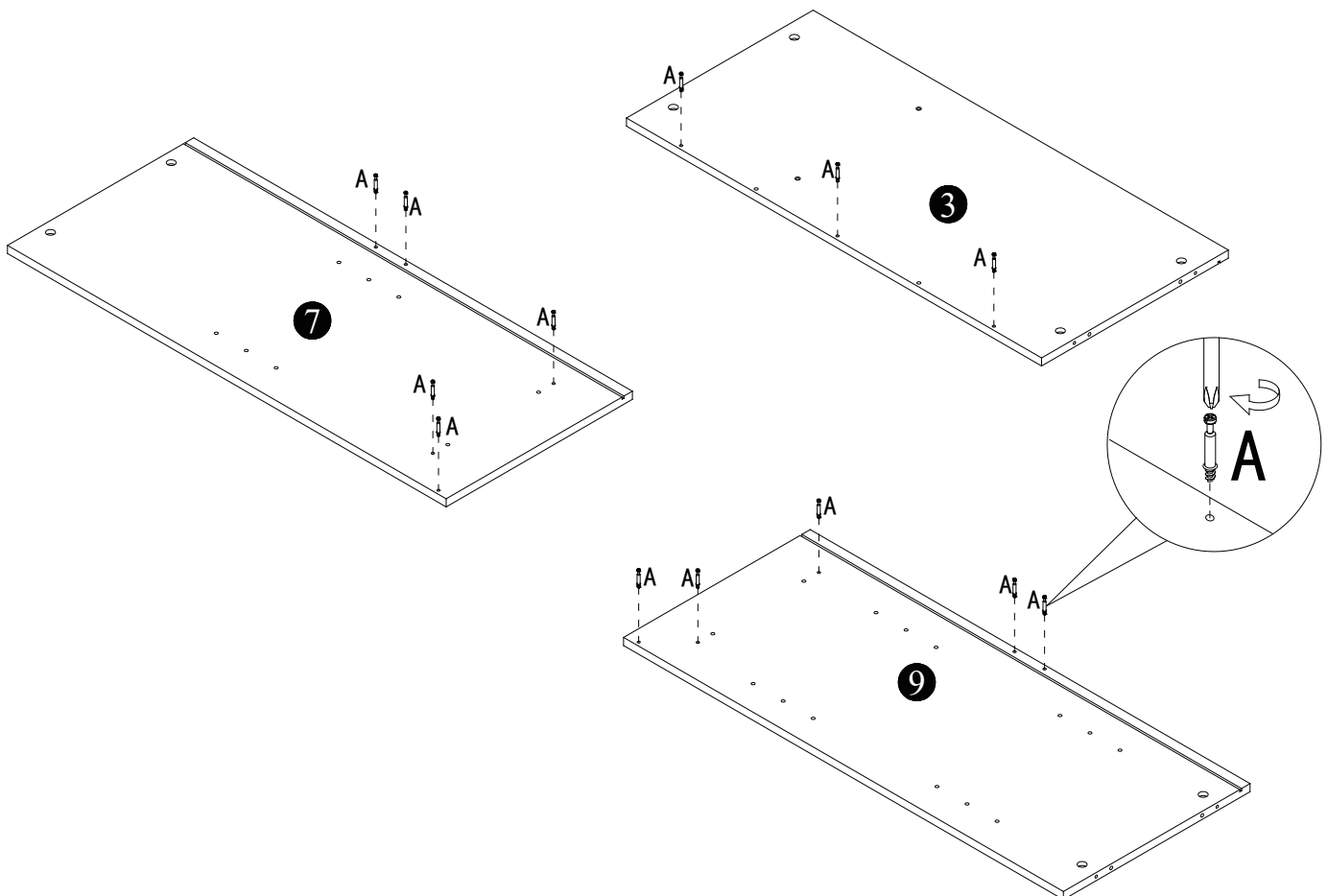
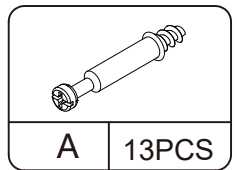

# Step 1

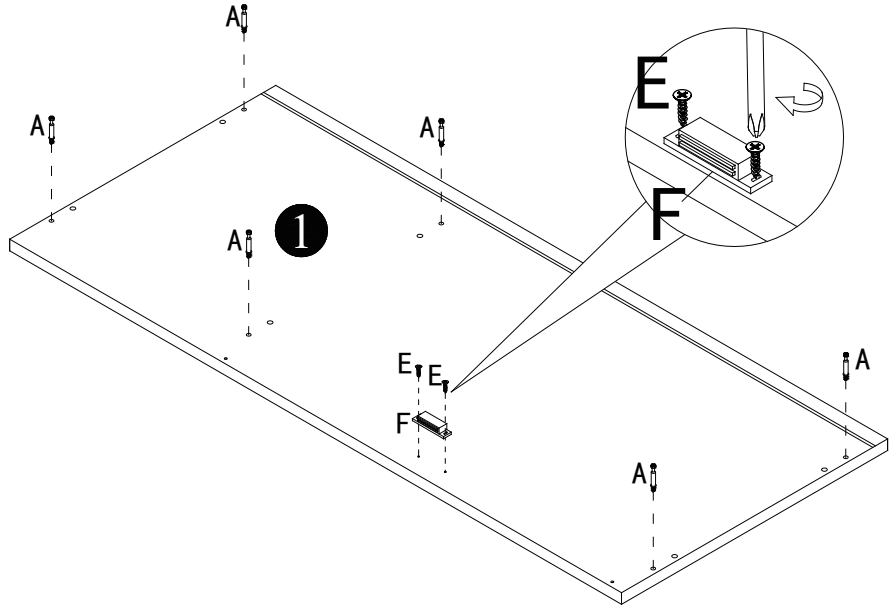
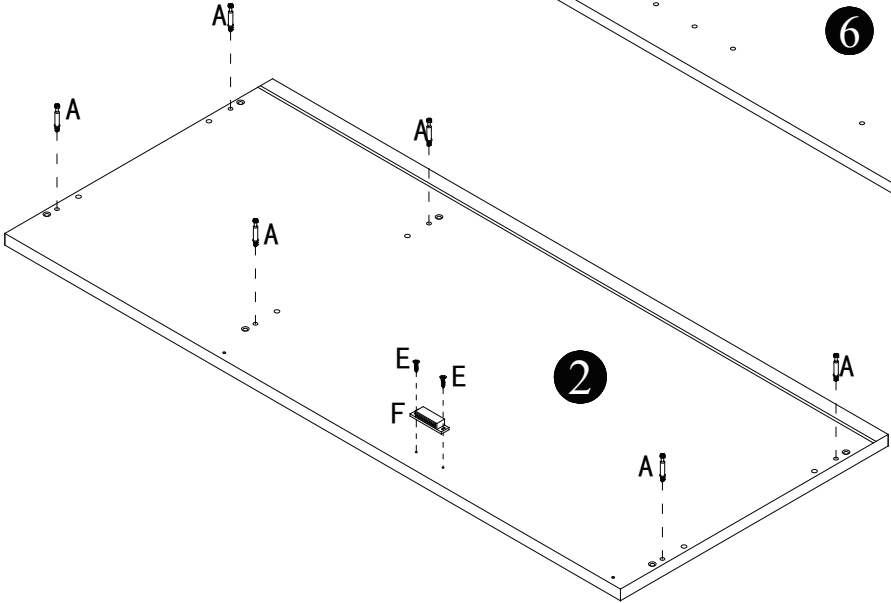
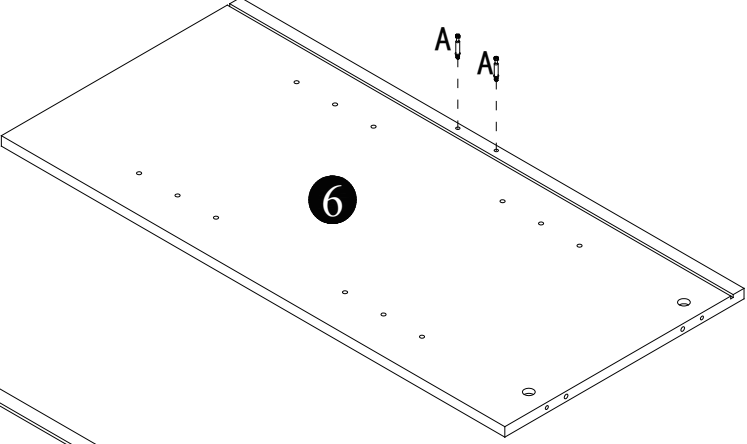
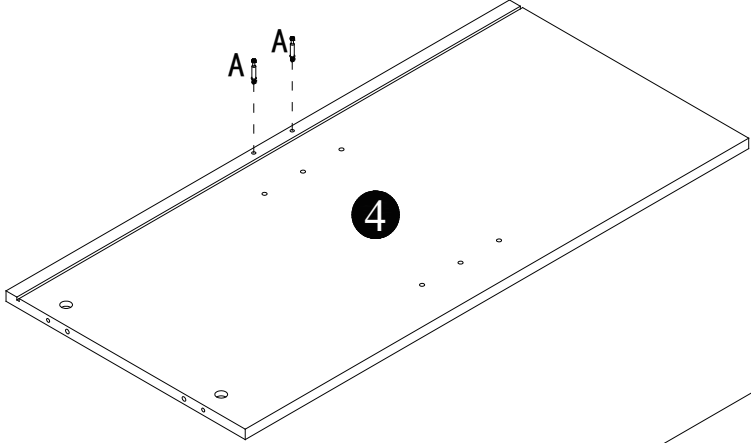
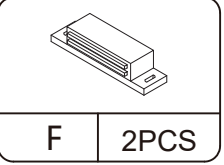
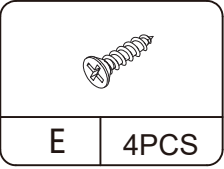
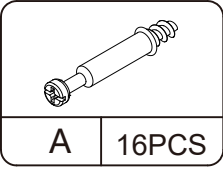

# Step 2



# Step 3

	
B	7PCS
C	2PCS

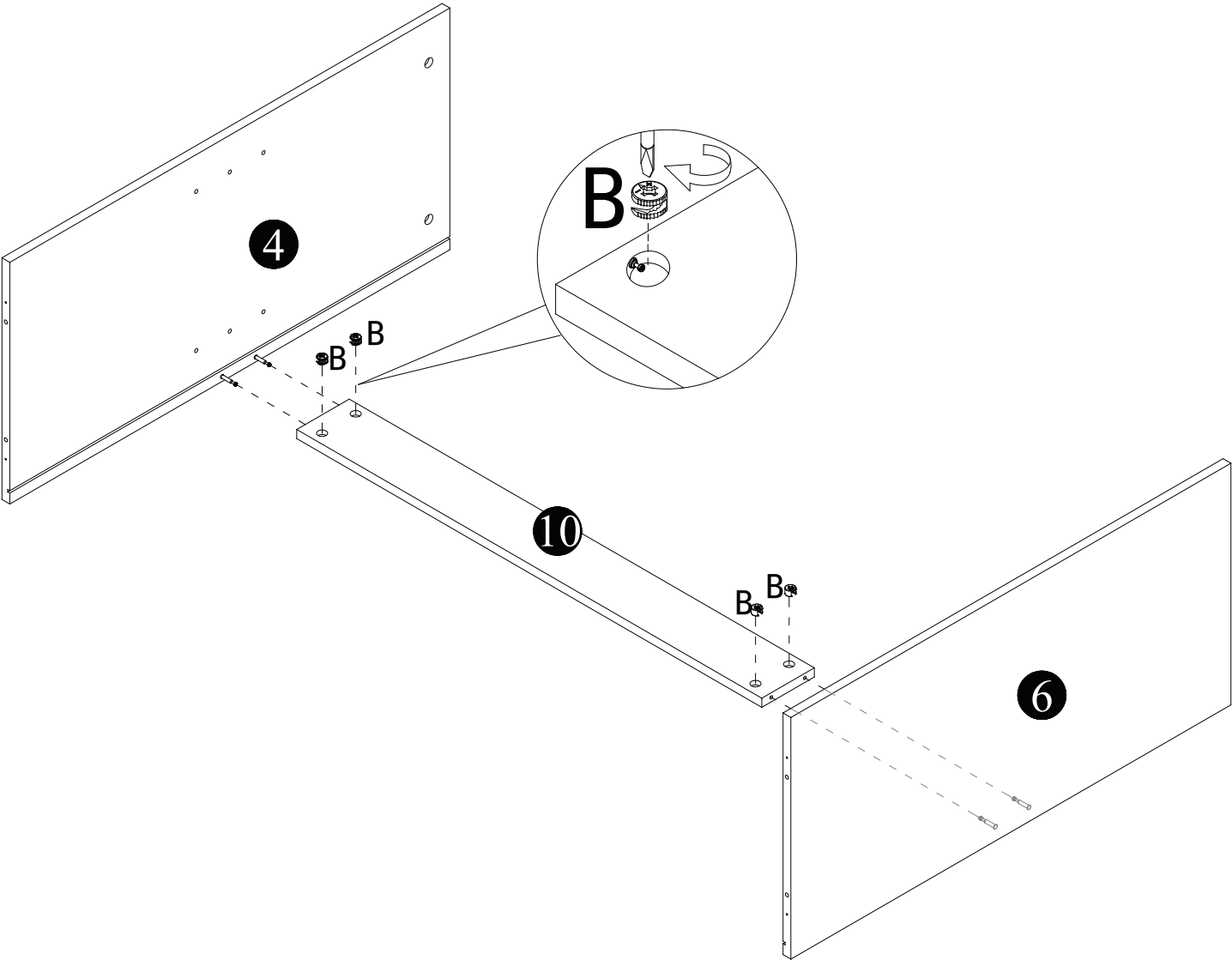
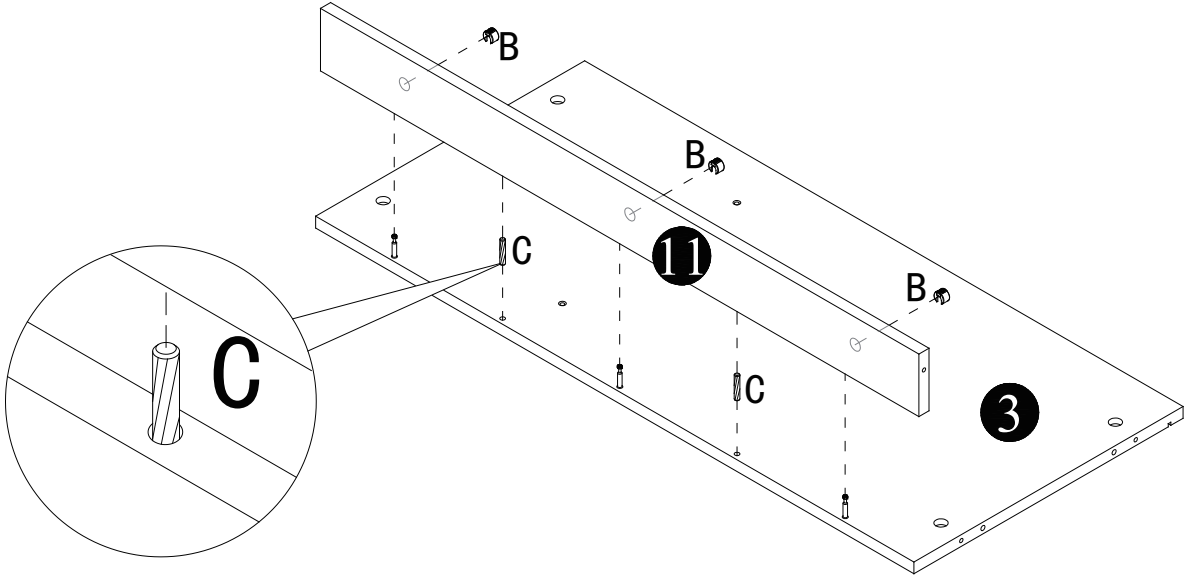

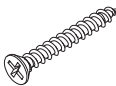

# Step 4

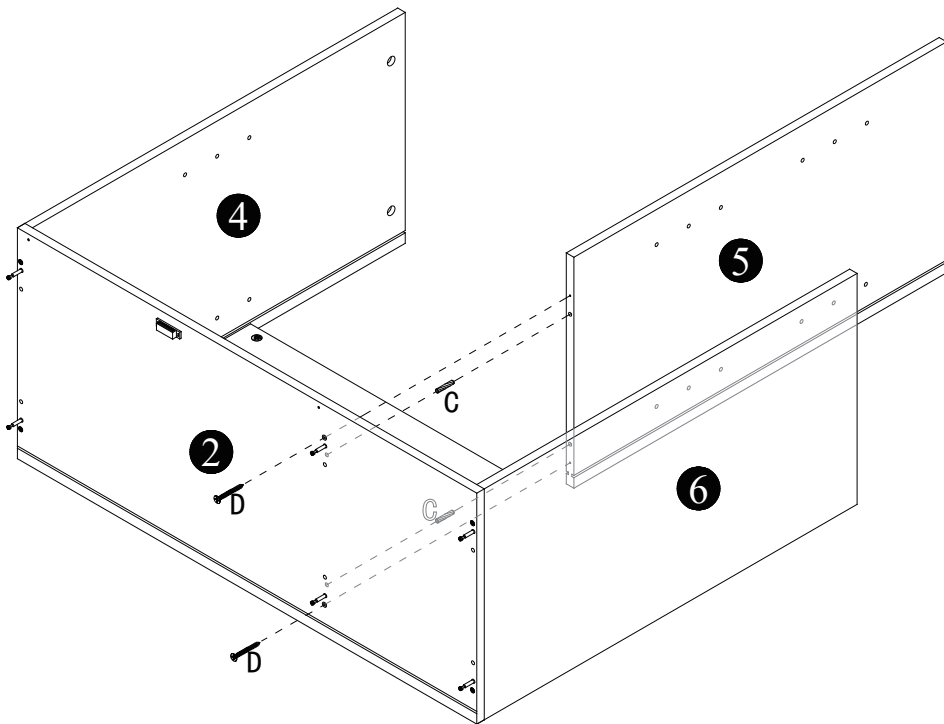
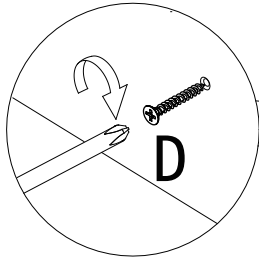
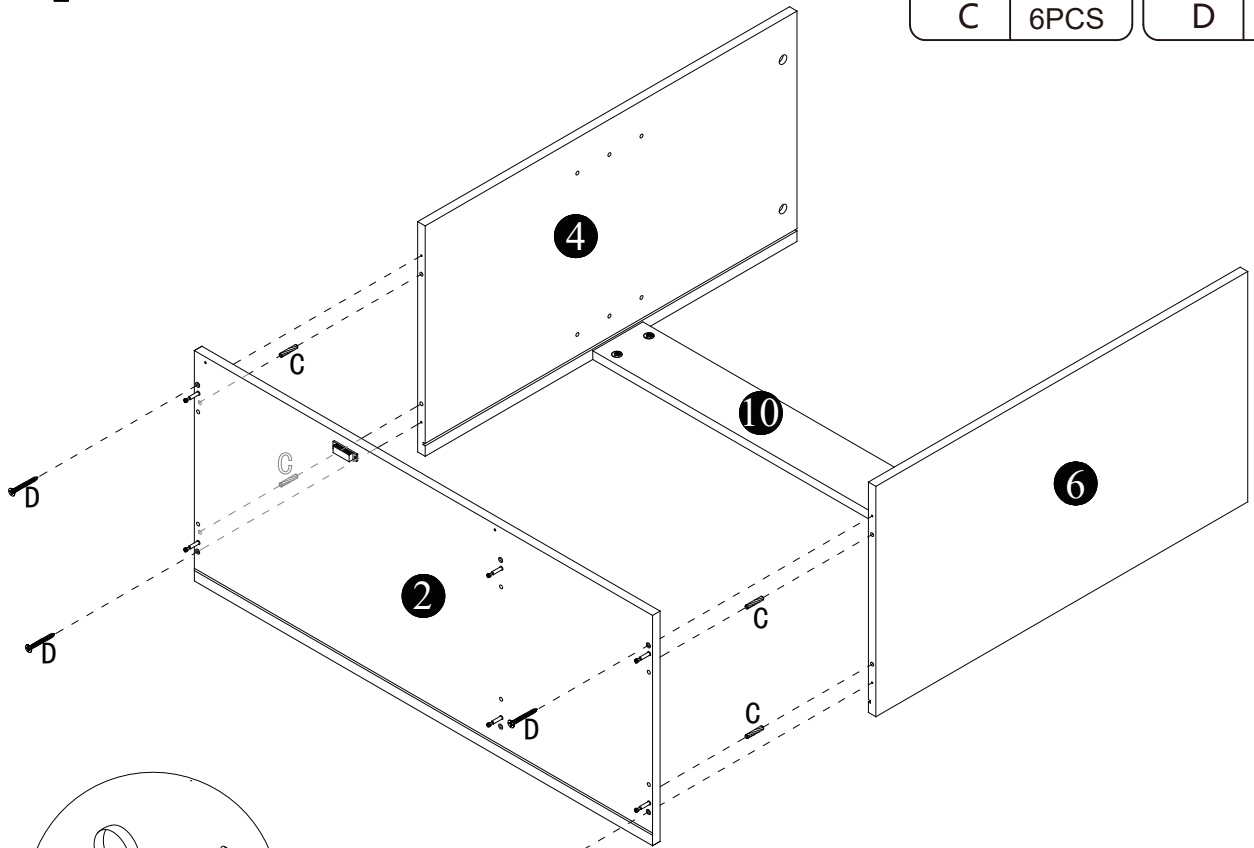
	
C	6PCS
D	6PCS





# Step 5

	
B	6PCS

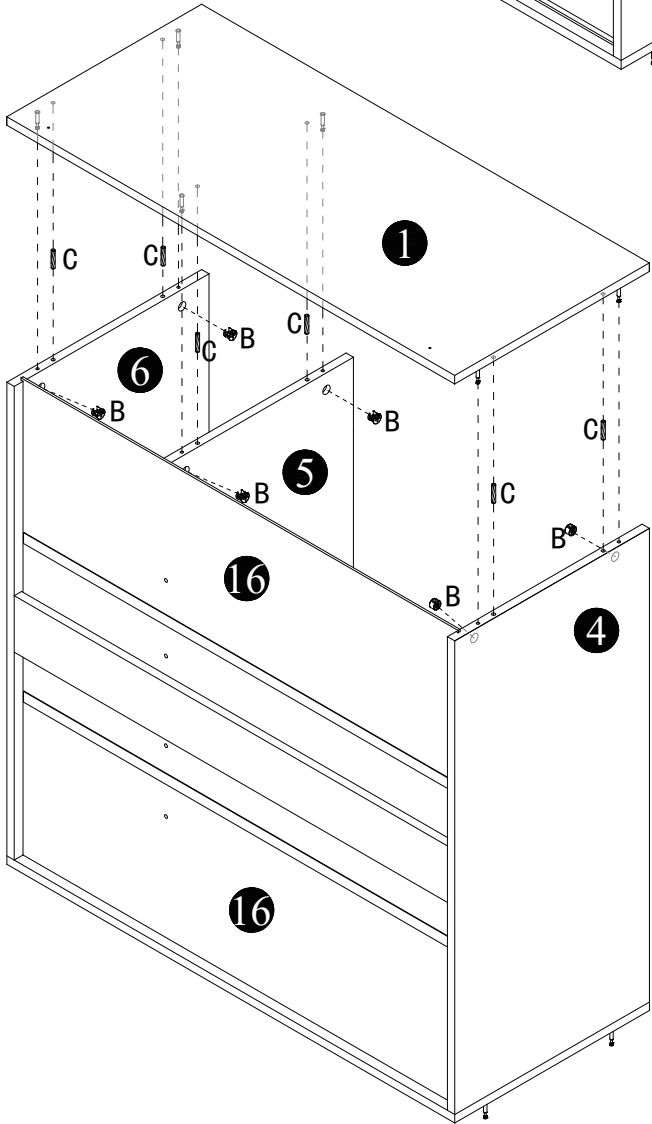
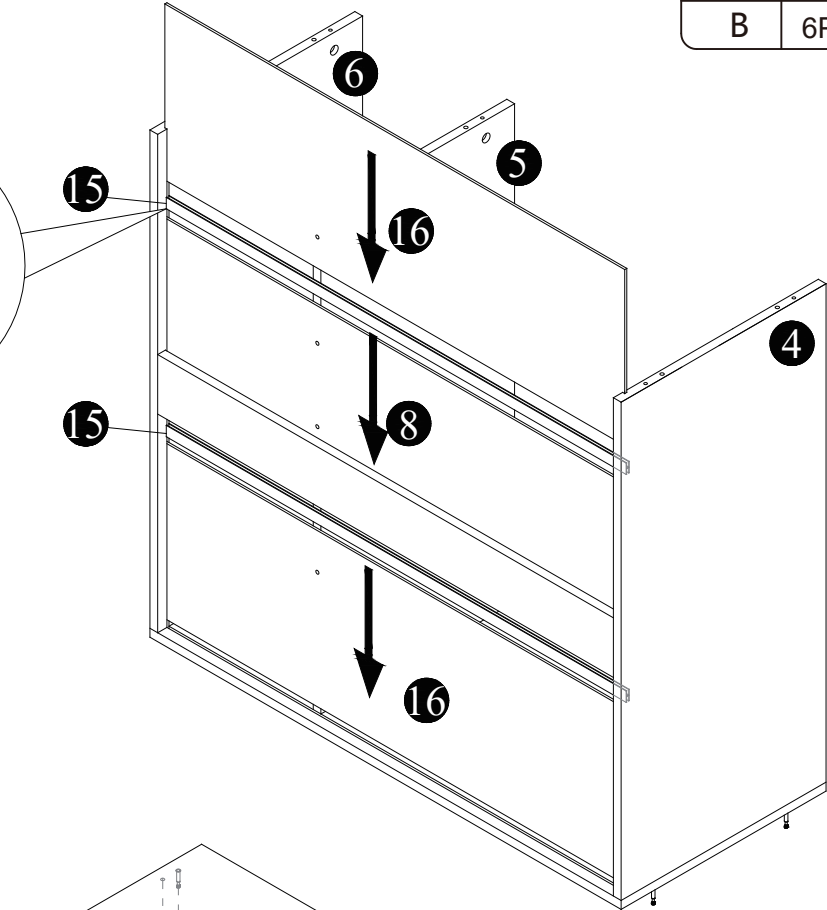
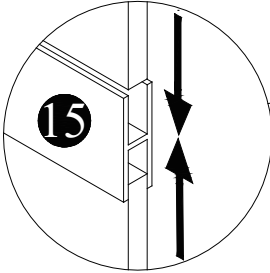
	
C	6PCS



# Step 6

	
B	10PCS
C	4PCS

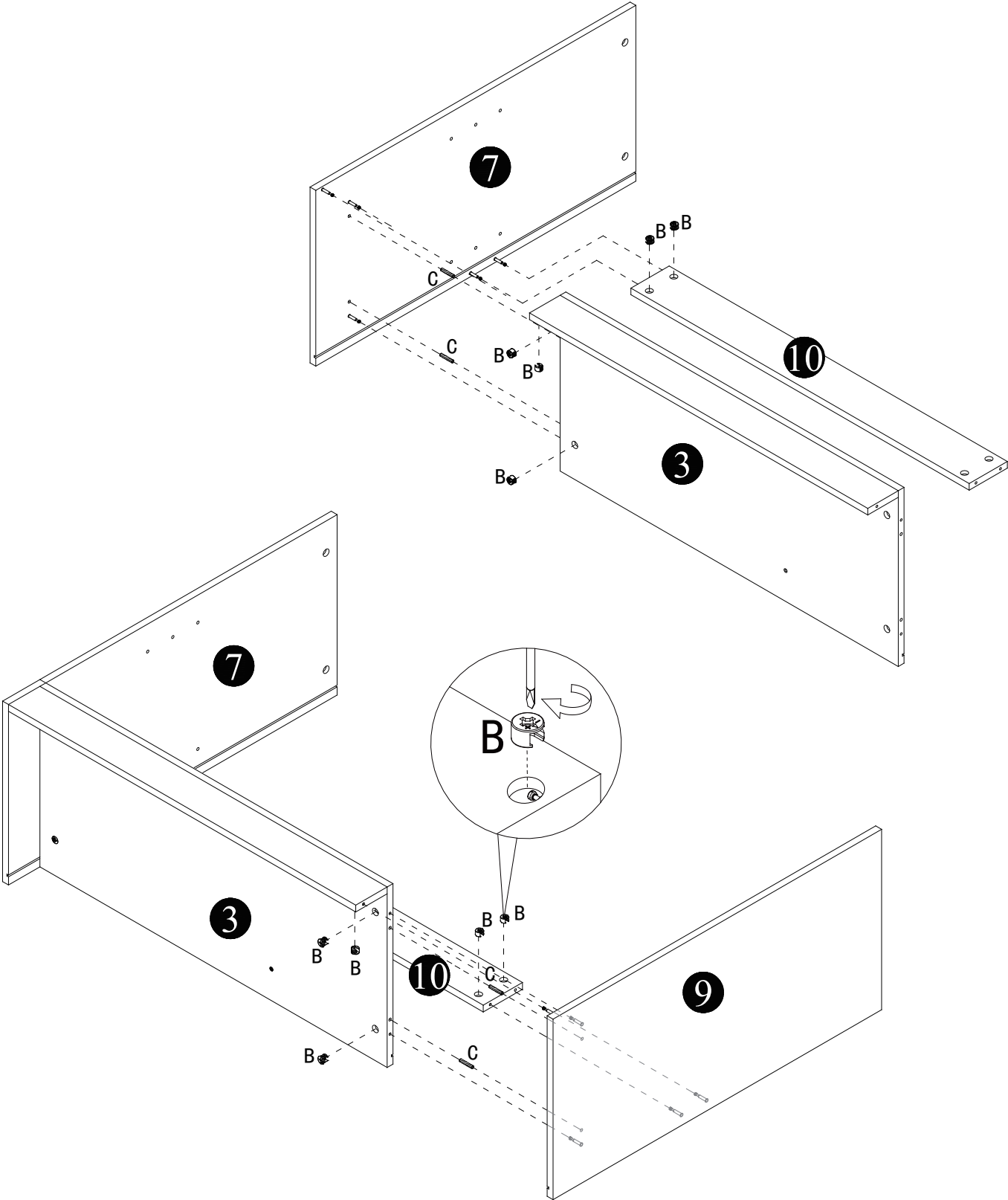

# Step 7

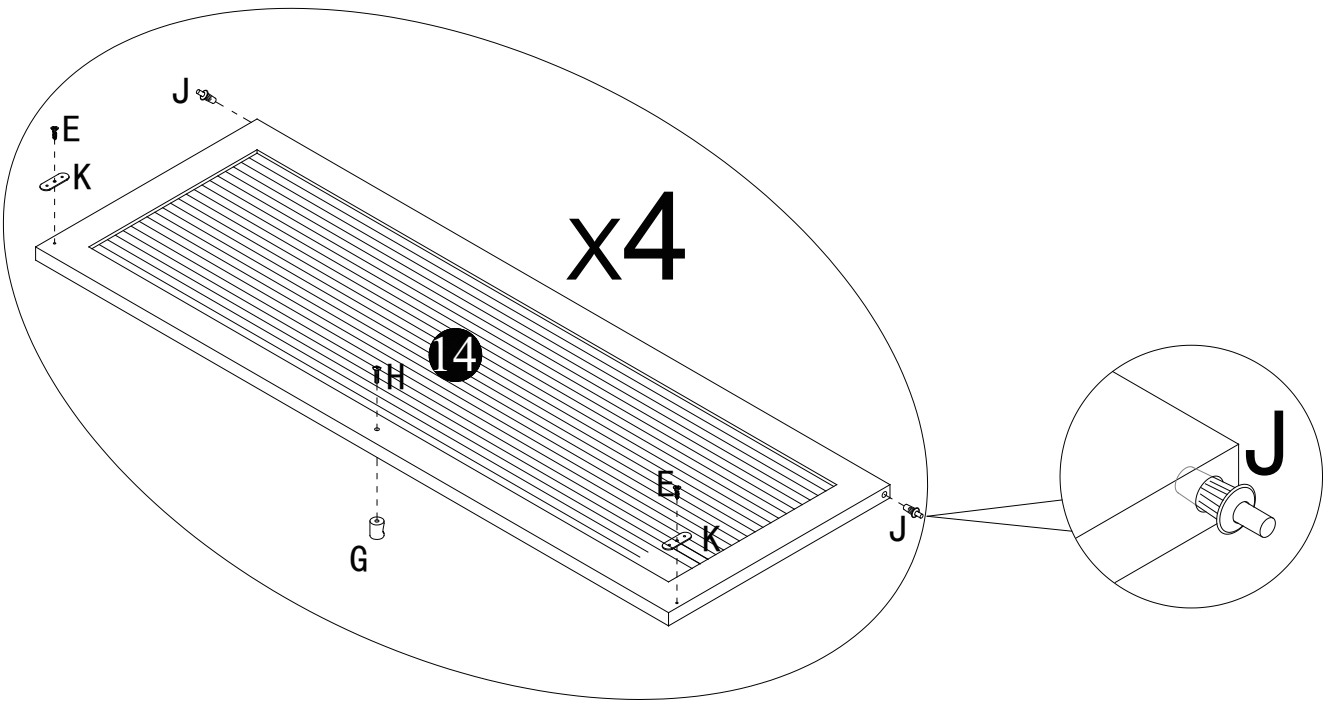
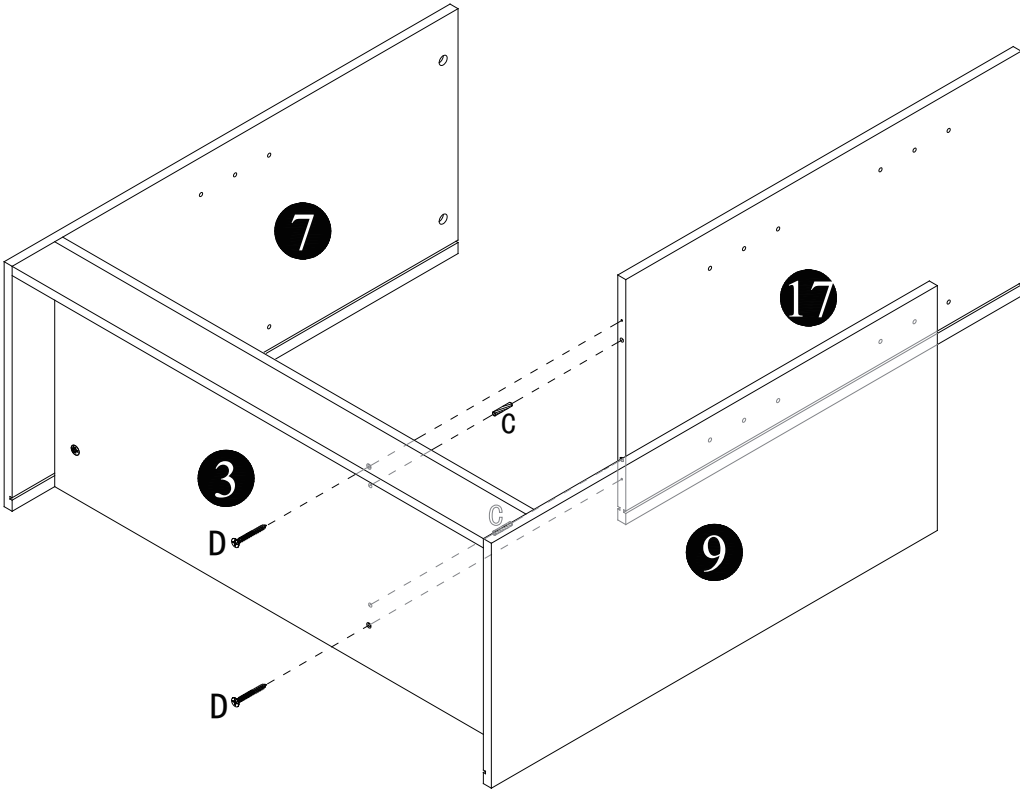
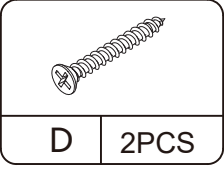
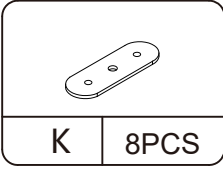
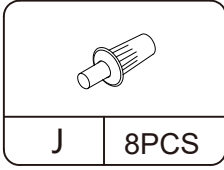
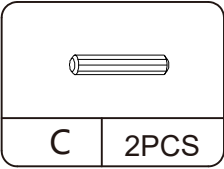
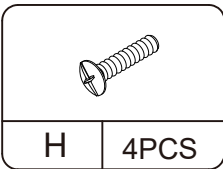
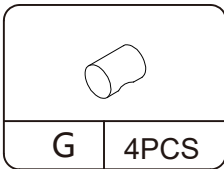
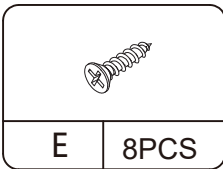

# Step 8

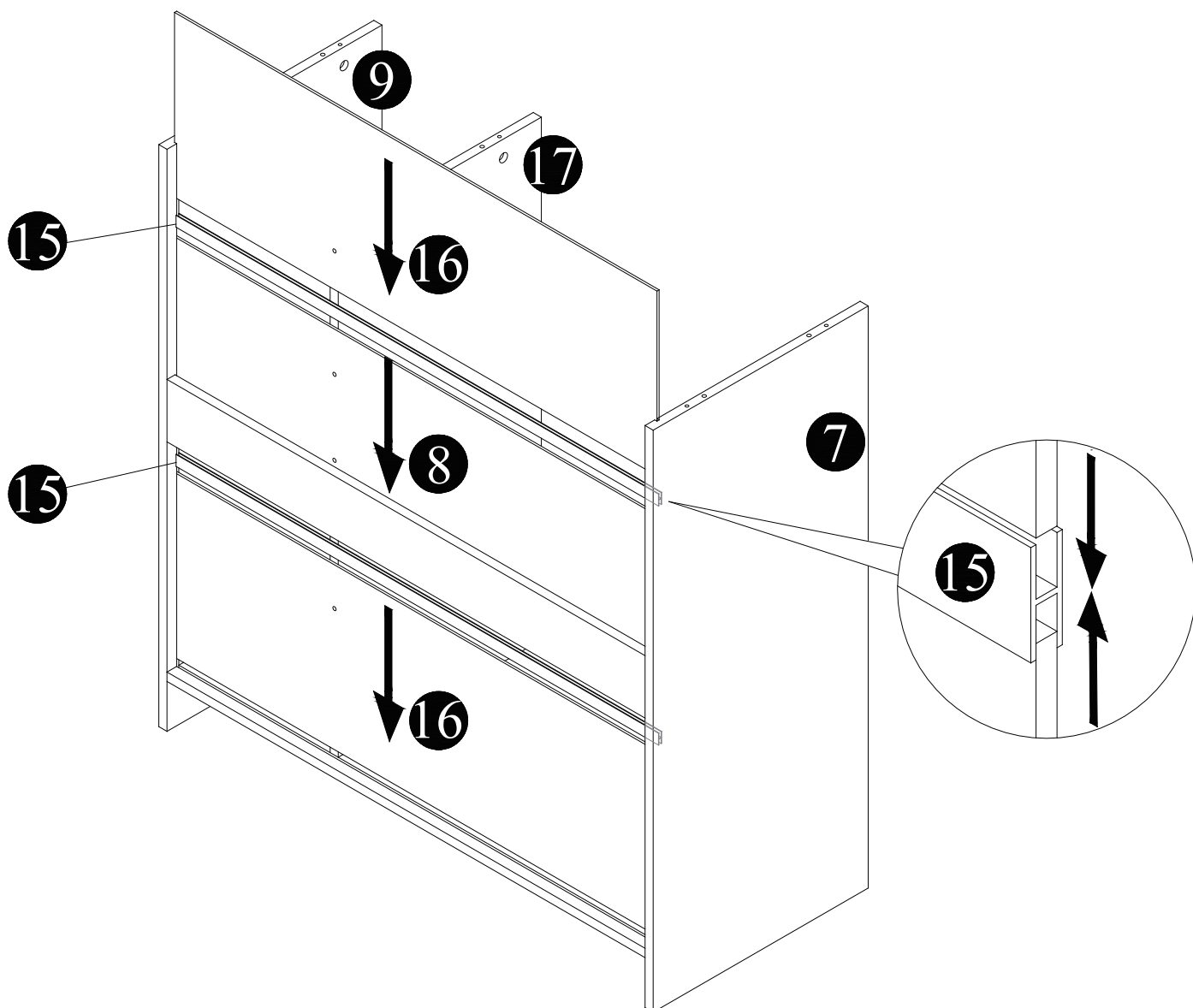

# Step 9

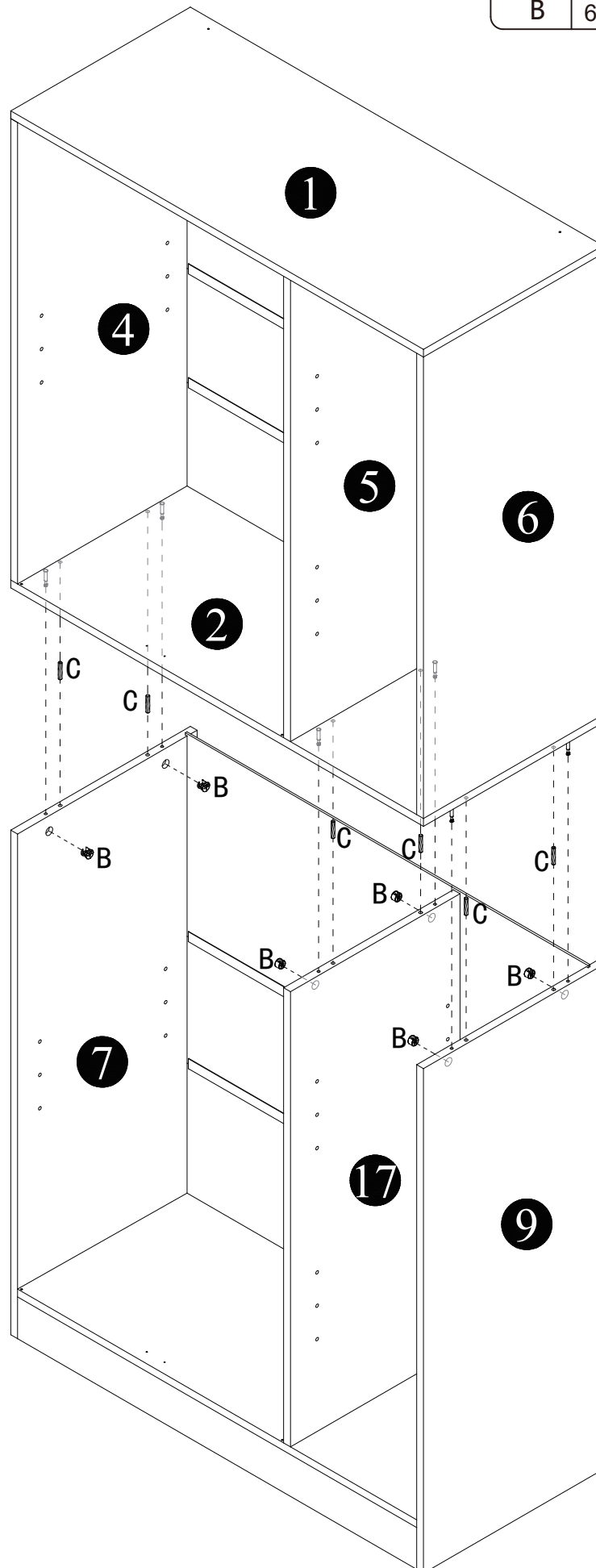
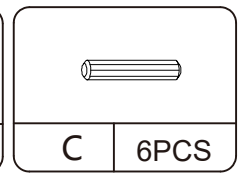
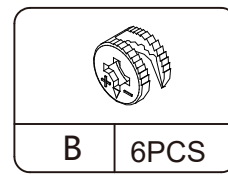



# Step 10

	
I	24PCS

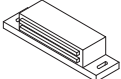
	
E	4PCS

	
F	2PCS

	
L	2PCS

	
M	2PCS

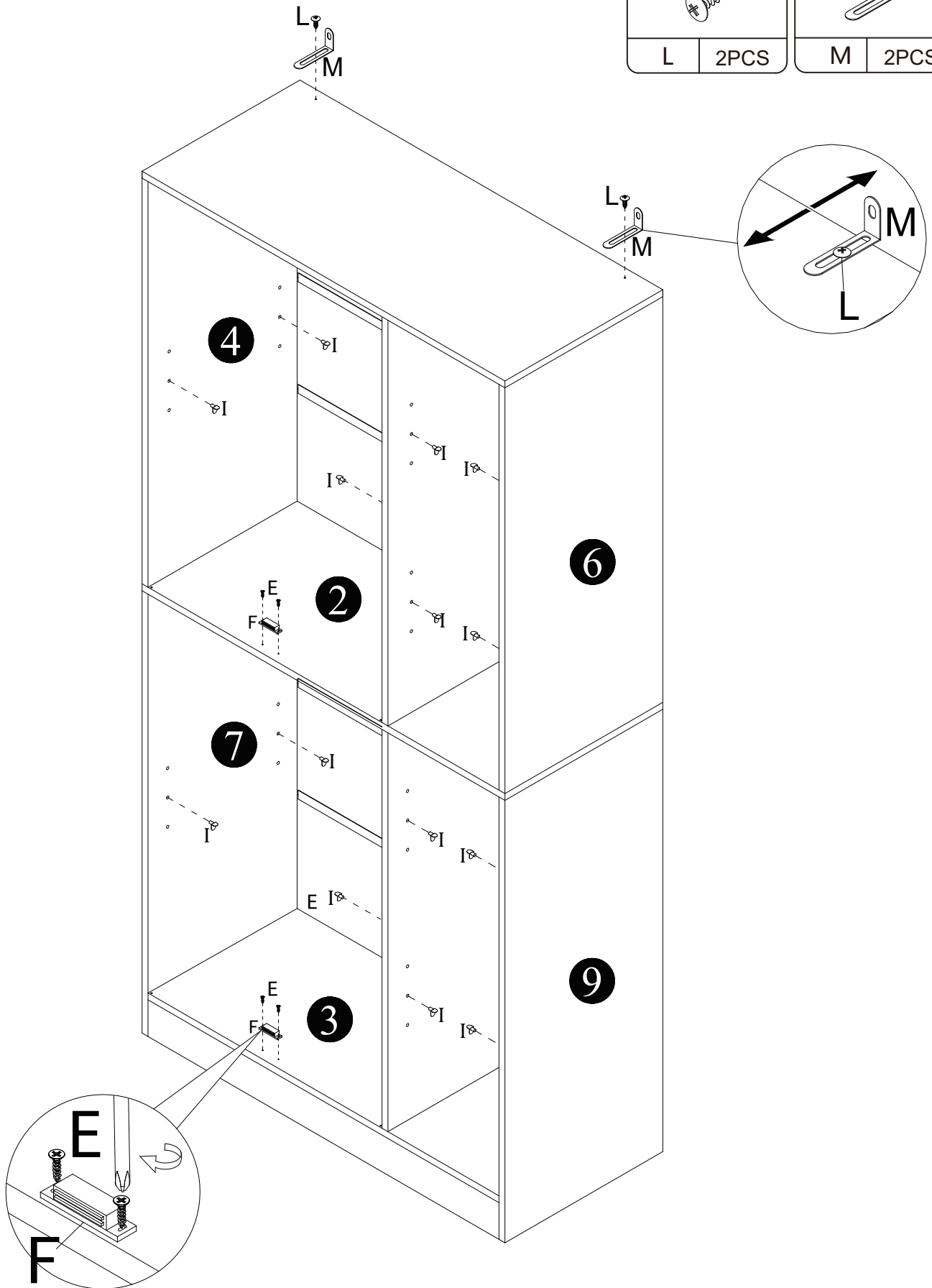

# Step 11

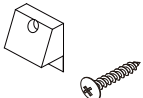
			
O	8PCS	P	8PCS

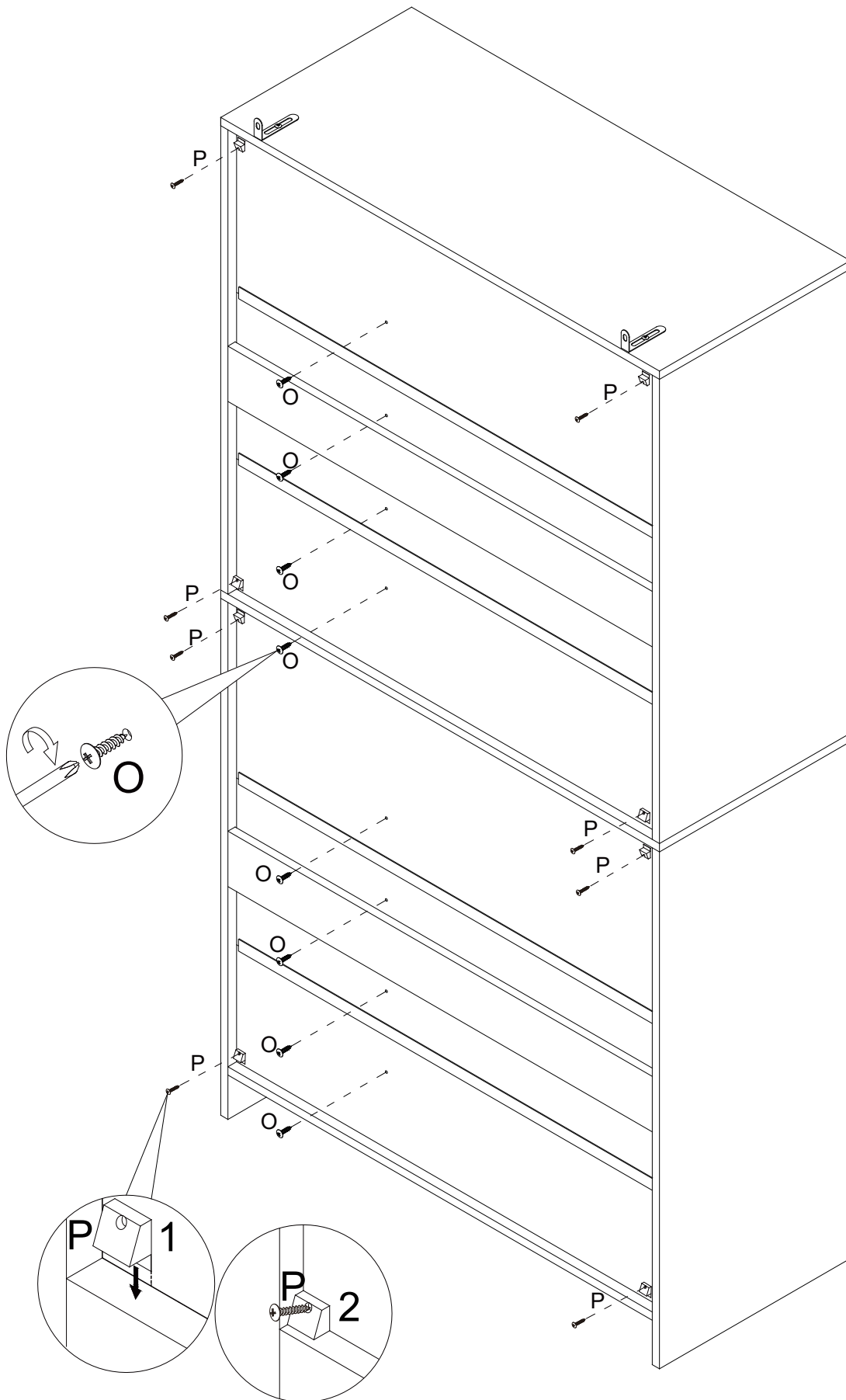

# Step 12

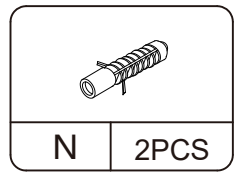

# 1

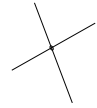
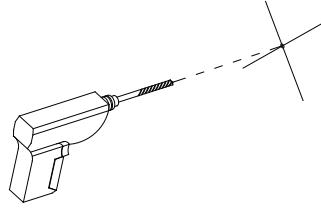

# 2

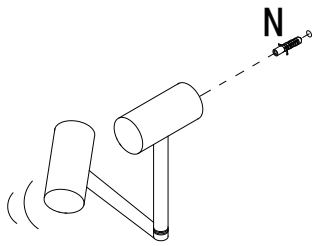

# Step 13

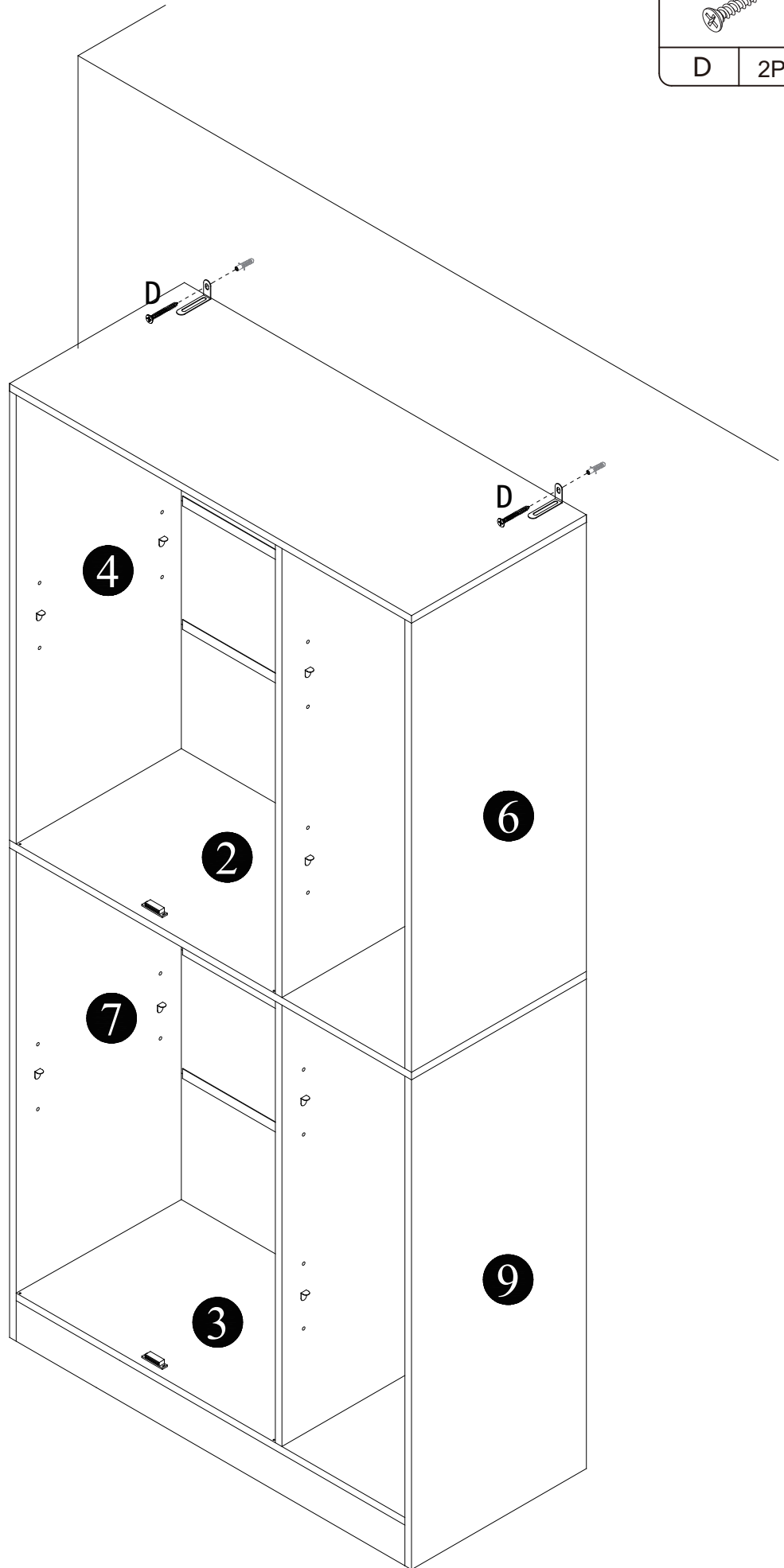
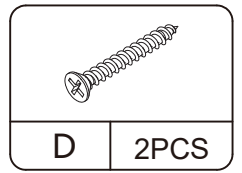

# Step 14

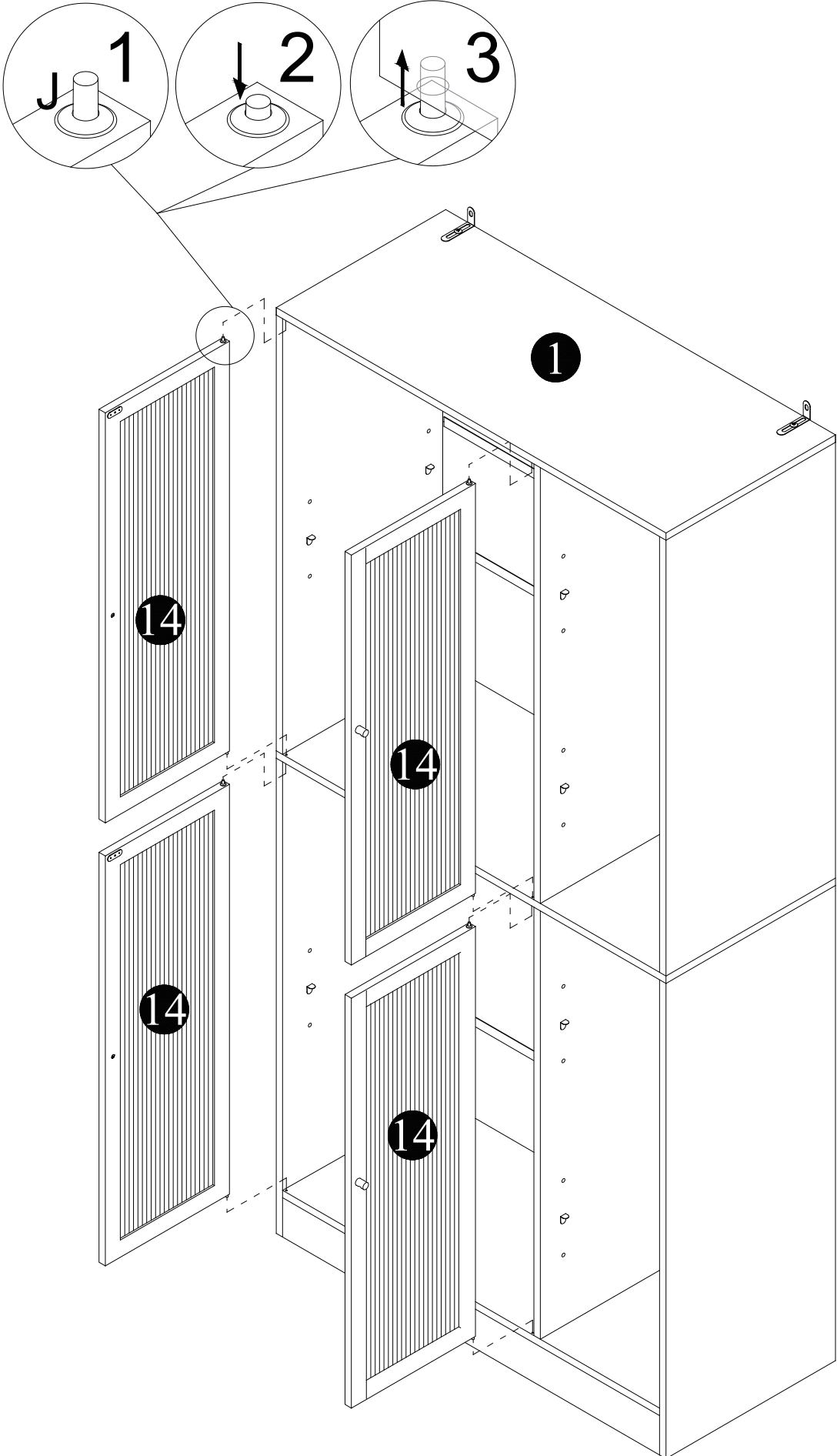

# Step 15

