

Assembly Instructions

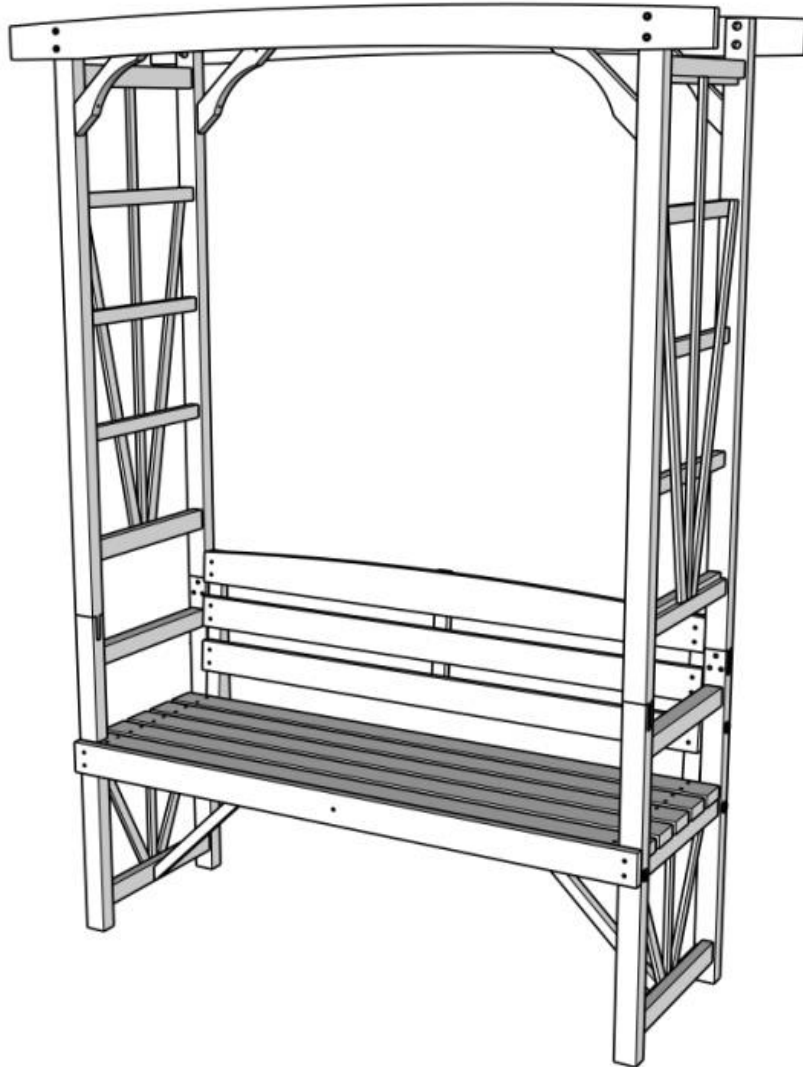



ARBOR BENCH

Caution: You must read this before you proceed

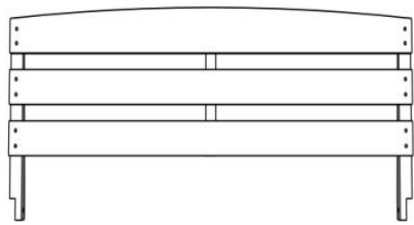
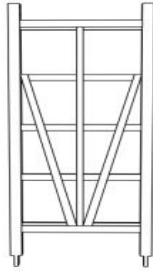
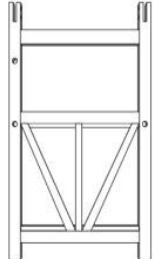
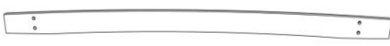

CAUTION : This Arbor with bench is NOT a TOY.
Keep your child / children at bay in the process of assembly.
Have at least 02 people to help when assembling this Arbor with Bench.

Parts List

Label	Picture	Description	QTY
A		Seat Board	1
B		Back Panel	1
C		Upper Support frame	2
D		Lower Support frame	2
E		Wood Lath	2
F		Wood Lath	1
G		Support Bars	4
H		Support Bars	2

Hardware

Label	Picture	Description	QTY
①		Bolt(M6x65MM)	9
②		Bolt(M8x90MM)	7
③		Nut(M6)	9
④		Nut(M8)	7
⑤		Screw(M3.5x30MM)	13
⑥		Screw(M4x40MM)	18
⑦		Screwdriver(Not provided)	1

Assembly Prerparation

Before Beginning Assembly

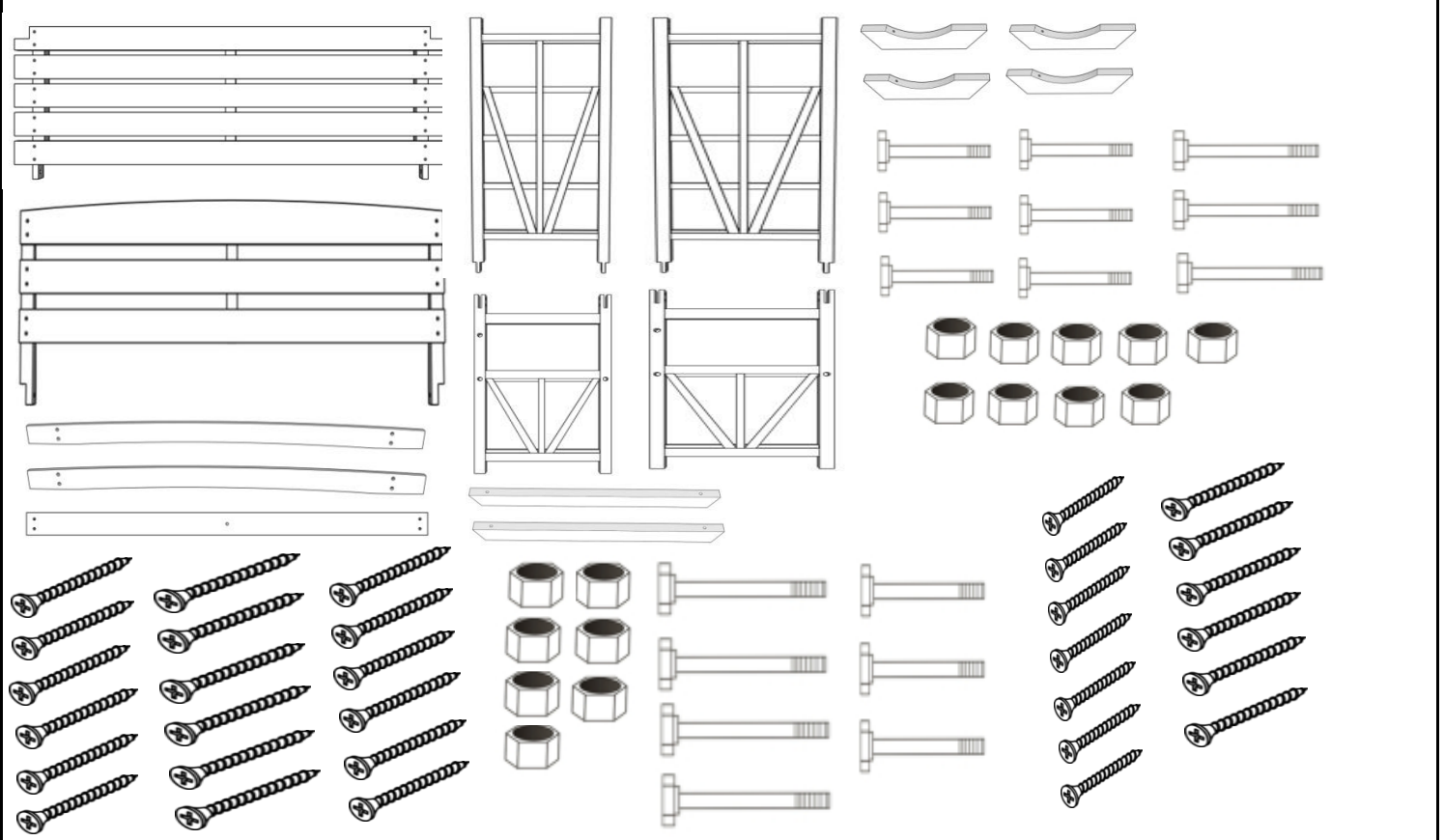

- Read instructions, cover to cover-



- Have 2 adults on hand for assembly-



- Do not assemble on flooring or carpet-



- Assemble on a clean non-marring surface (packing foam)-



- Save all packaging until finished-

Assembly Steps

Overview

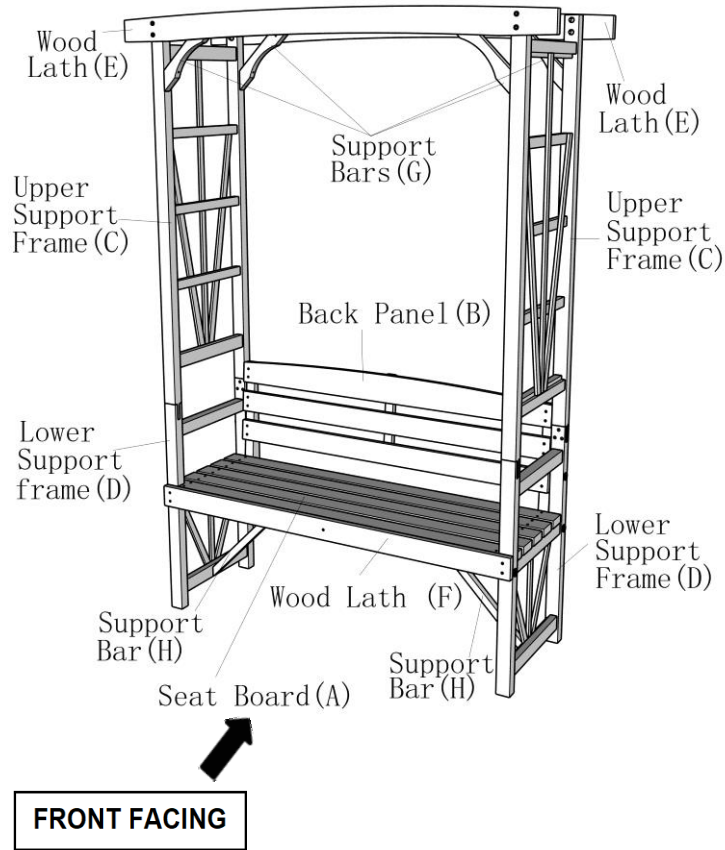

This Arbor with Bench has multiple parts and may require up to 30 minutes to assemble. To give you an overview of the Arbor with Bench parts, the above picture is to help you put the various parts into perspective. Please read through the instructions below to familiarise yourself with the parts and steps before assembly.

Step 1

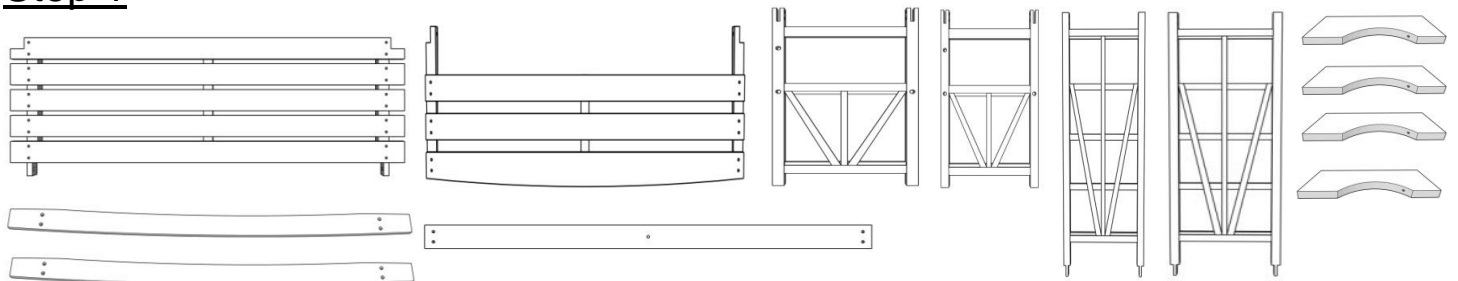

Unpack and place all parts on a clean, non-marring surface.

Step 2

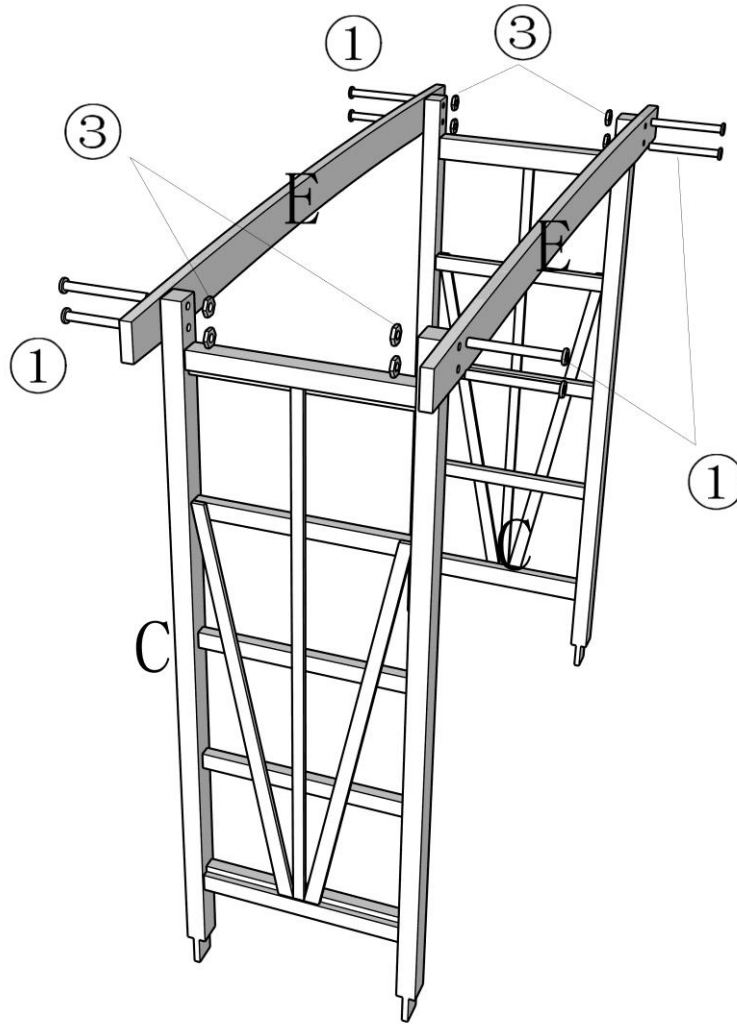

Connect the Wood Lath(E) and the Upper Support Frame(C) with Bolts(①)and Nuts(③),as shown in the picture. In this step tighten the bolts.

Step 3

NOTE:

Install all using
Screw(⑥) here.

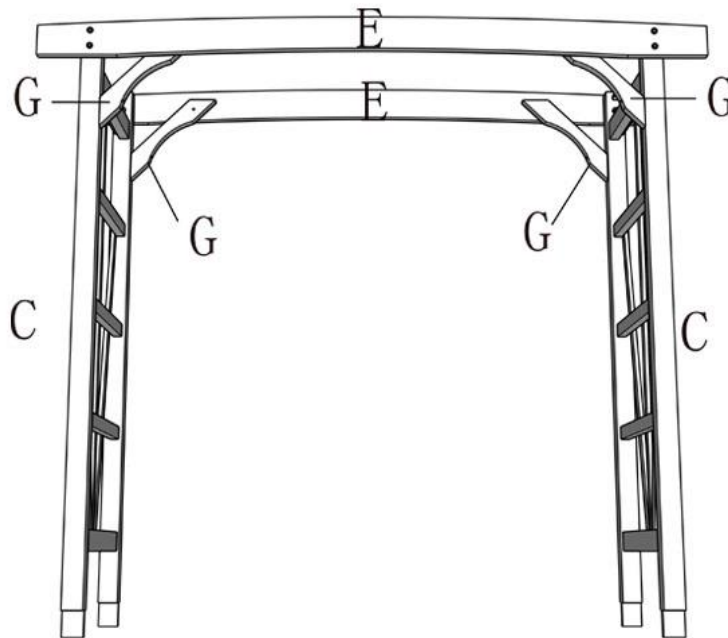
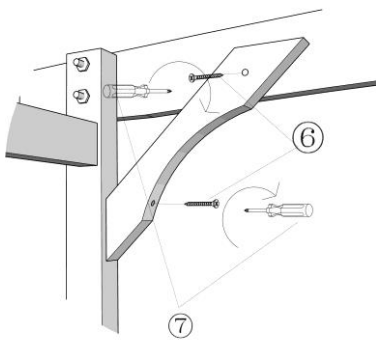

Connect the Support Bars(G), the Wood Lath(E) and the Upper Support Frame (C) with Screws(⑥)using the Screwdriver(⑦), as shown in the picture. In this step,tighten the screws.

Step 4

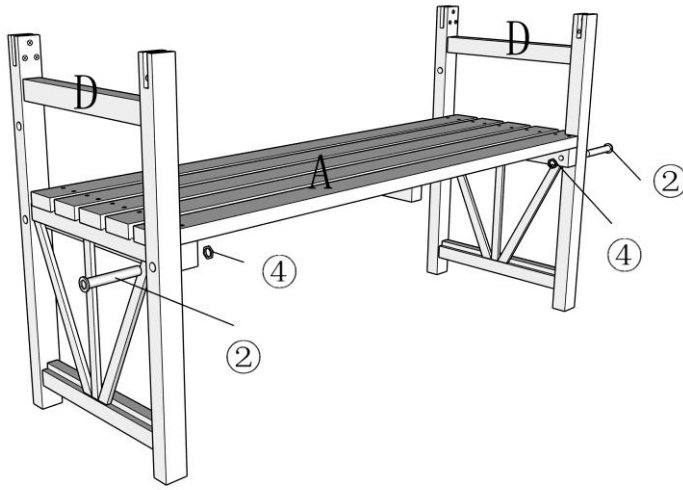

Connect the Seat Board(A) and the Lower Support Frame(D) with Bolts(2)and Nuts(4), as shown in the picture. In this step tighten the bolts.

Step 5

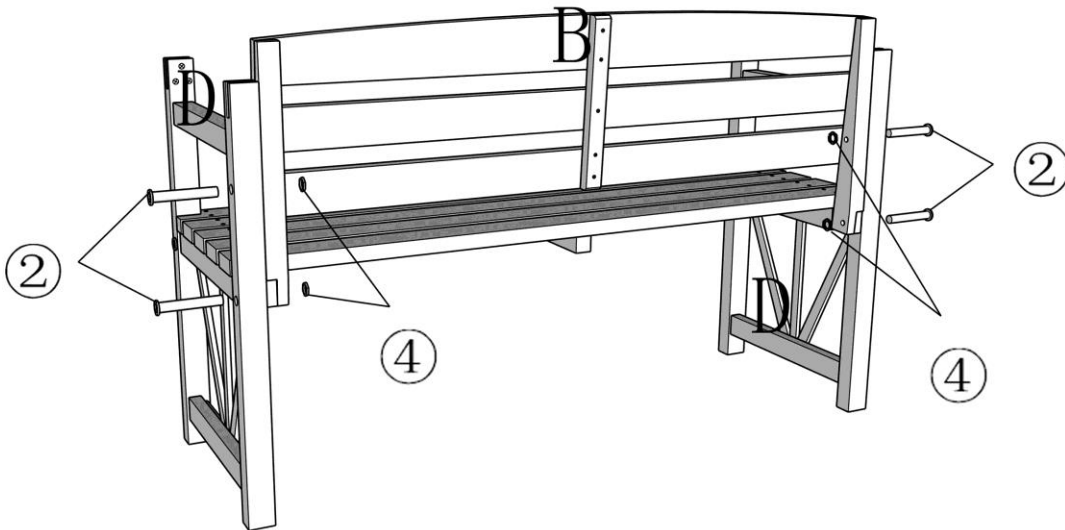

Connect the Back Panel(B) and the Lower Support Frame(D) with Bolts(2)and Nuts(4), as shown in the picture. In this step tighten the bolts.

Step 6

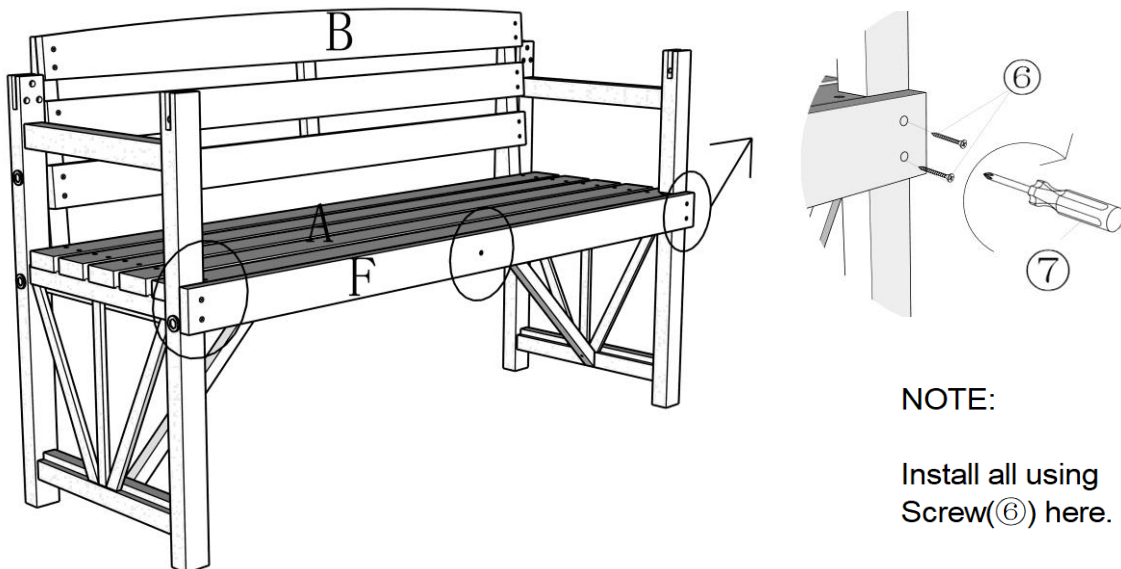

Connect the Wood Lath(F) and the Lower Support Frame(D) with Screws(6)using the Screwdriver(7),as shown in the picture .In this step tighen the screws.

Step 7

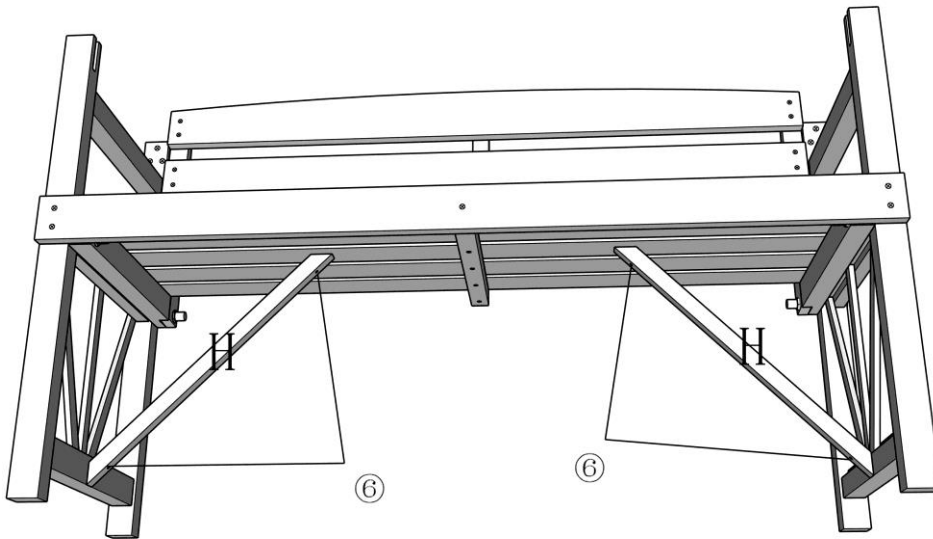

NOTE:

Install all using
Screw(⑥) here.

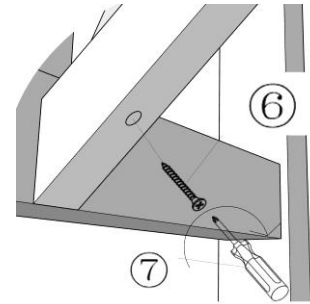

Connect the Support Bars(H), the Seat Board(A) and the Lower Support Frame (D) with Screws(⑥) using the Screwdriver(⑦), as shown in the picture. In this step, tighten the screws.

Step 8

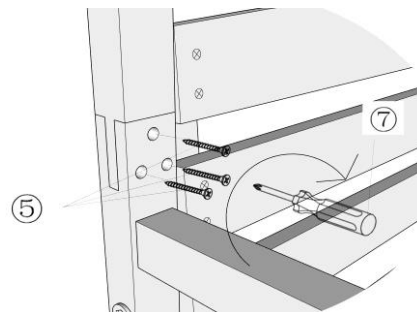
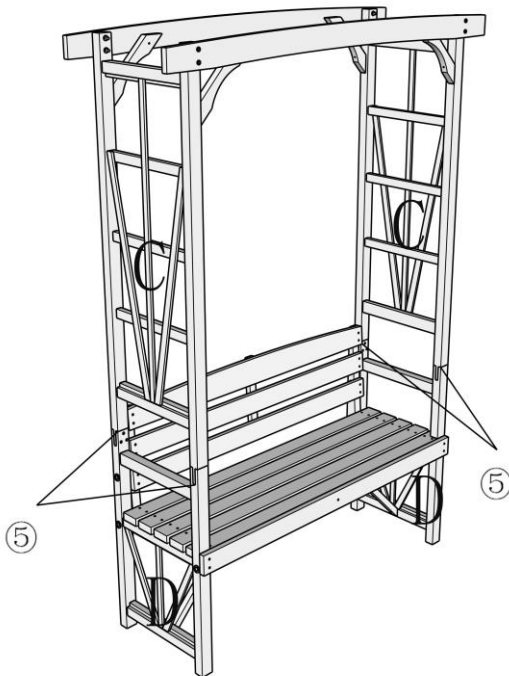

NOTE:

Install all using
Screw(⑤) here.







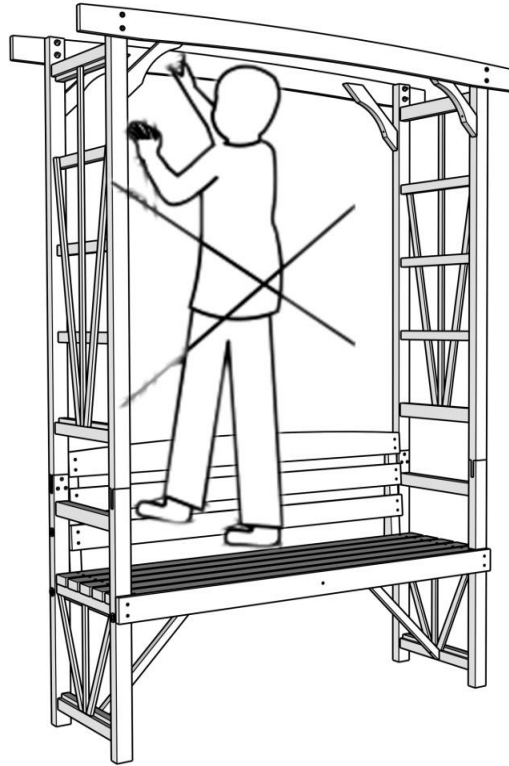

Connect the Upper Support Frame(C) and the Lower Support Frame(D) with Screws(⑤) using the Screwdriver(⑦), as shown in the picture. In this step tighten the screws. (At least two adults to work together.)

⚠ WARNING

Serious or fatal crushing injuries can occur from tipping furniture.



Care & Maintenance

-  ● Do not put hot items directly on furniture surface
-  ● Do not clean furniture with harsh cleansers or polish.
-  ● To obtain the longest lifespan of your outdoor products, minimizing exposure to direct sunlight is recommended.
-  ● Children should not climb or jump on the furniture.
-  ● Do not write on furniture without a padded barrier to protect the surface.
-  ● To obtain the longest lifespan of your outdoor products, avoid extended and lengthy exposure to rain, snow, and direct sunshine. Whenever possible cover the product and /or place under patio or awnings.
-  ● Not for commercial use. For residential use only .
-  ● Stains may be removed with mild soap solution and damp cloth.
-  ● Dust and pick-up spills using a clean, non-colored, lint-free cloth .