

Tribesigns

DESIGNED FOR LIFE

Assembly Instructions

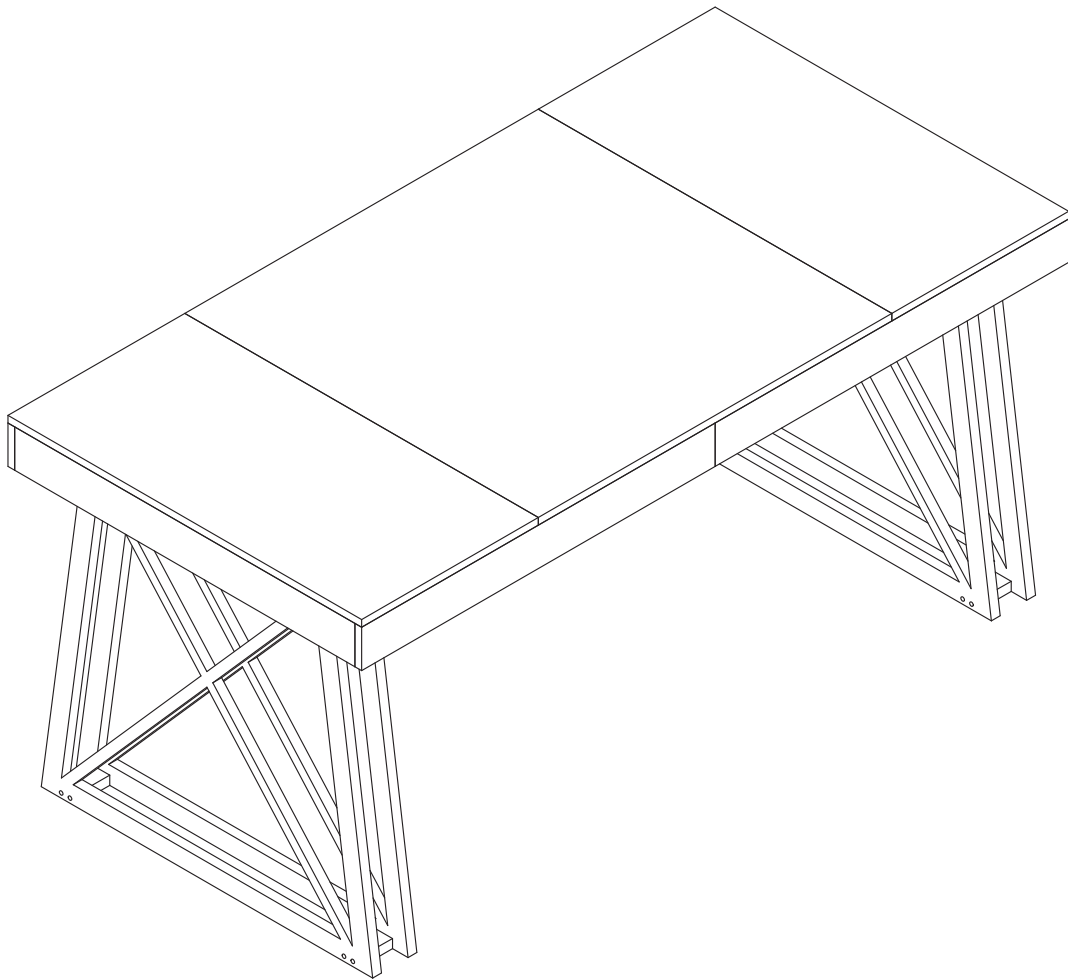

Executive Desk

Model No.
HOGA-JW1054

 **LITTLE TREE**
Little Tree by Tribesigns

www.tribesigns.com



Contact Us

We're here to help you.



Your satisfaction is our top priority. If you encounter any issues with this product, such as missing or damaged parts, we're here to help. Please retain the original packaging and take photos of the packaging and the product, then contact us as soon as possible.

Warm Tips

1. Carefully read these instructions and keep them for future reference.
2. Check the parts list and confirm everything's there before starting assembly.
3. When assembling, put all parts on a soft, smooth surface like a carpet to avoid scratches.
4. Don't fully tighten screws until all parts are confirmed in place to avoid misalignment.

How to Get the Assembly Video

Step 1 Scan the QR code.



Installation Video

Step 2 Search with the Model No. (on the bottom left corner of the title page)

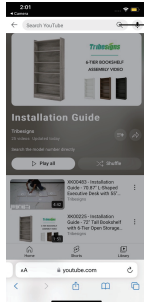

HOGA-JW1054

Note: If you can't find the assembly video, please contact us.

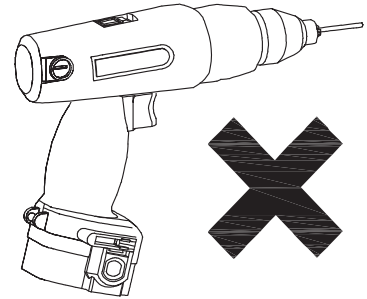
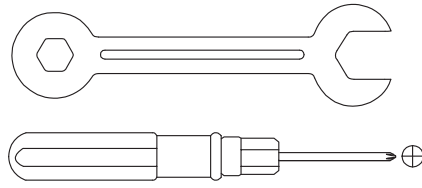
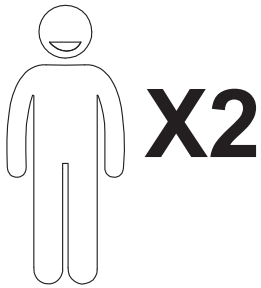

We recommend using hand tools for assembly.

If an electric screwdriver is used, reduce power and torque to avoid damage to the product.

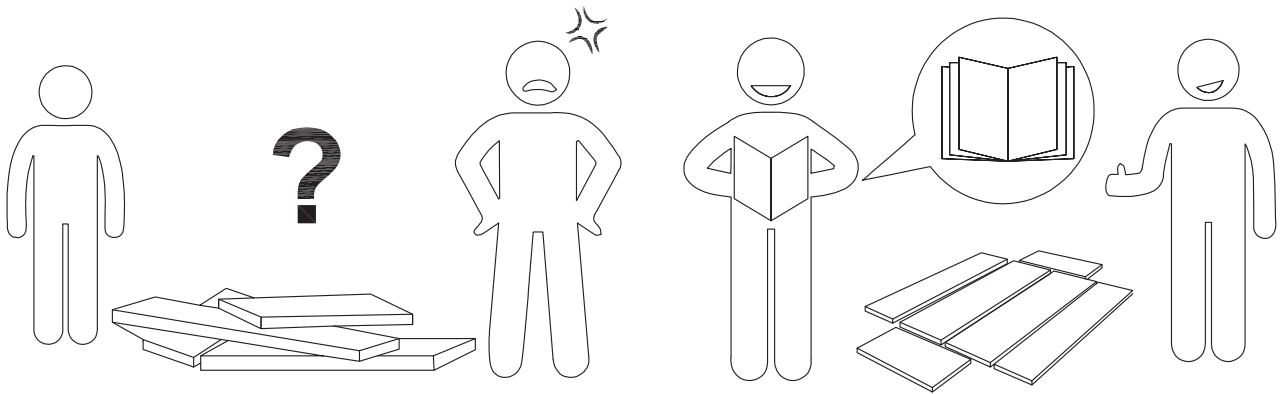

AVOID SCRATCHES

In order to avoid scratching, this furniture should be assembled on a soft surface, such as a rug.

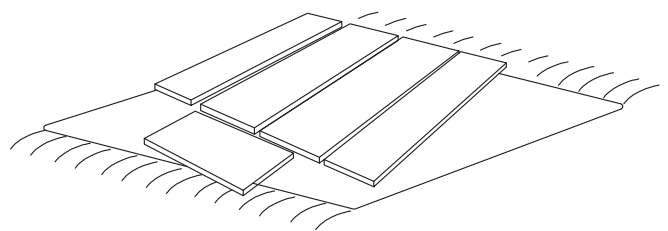
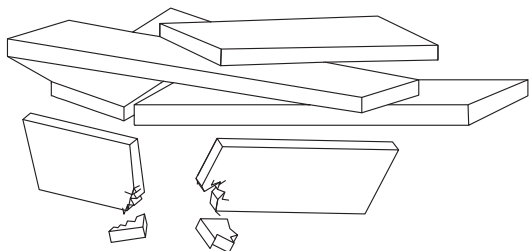

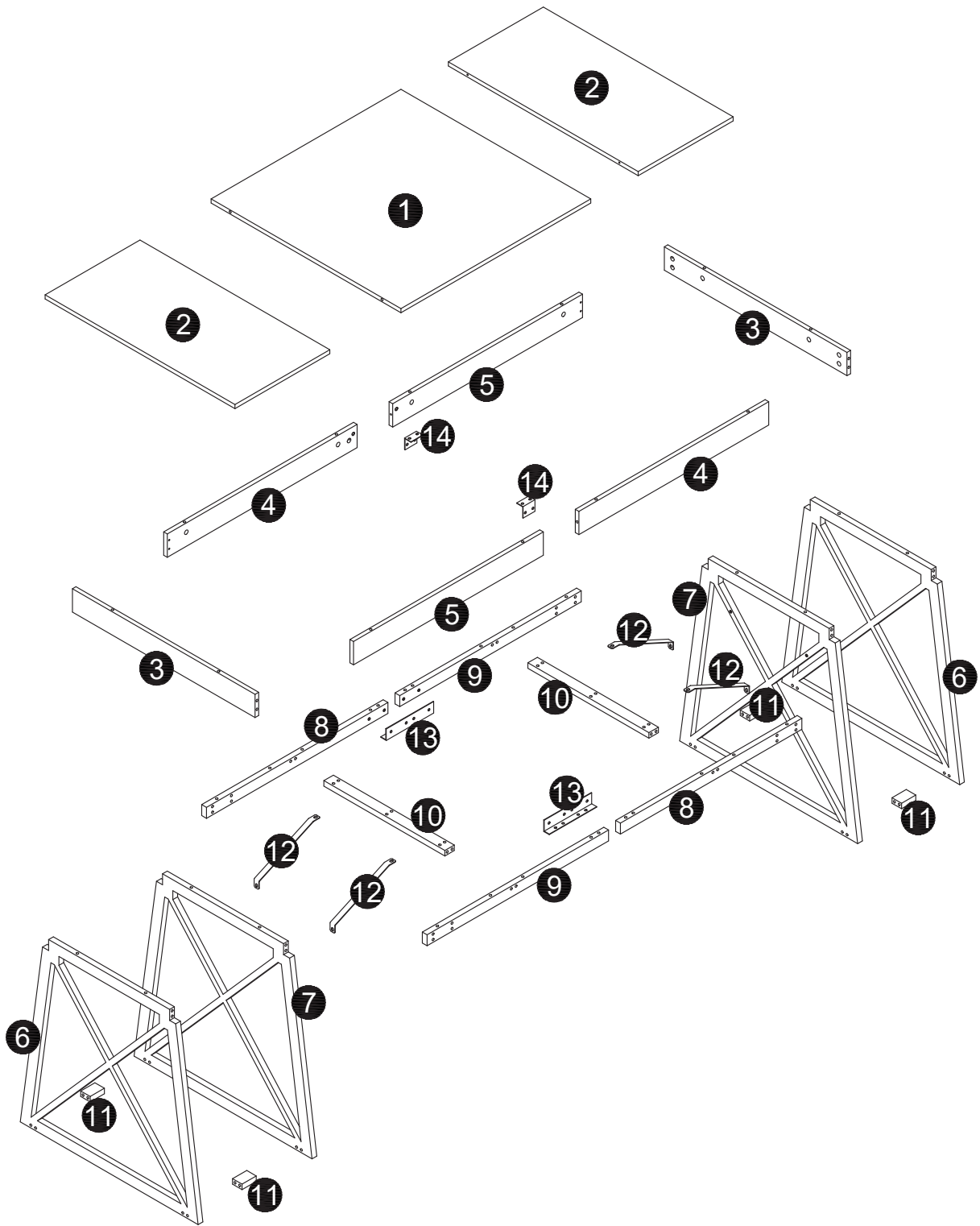

⚠ Caution

Make sure all parts are included. Most board parts are labeled or stamped on the raw edge. Contact us for a free replacement if you encounter any damaged or missing parts.







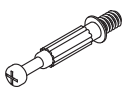

Parts List

<p>1</p> <p>1 pc</p>	<p>2</p> <p>2 pcs</p>	<p>3</p> <p>2 pcs</p>	<p>4</p> <p>2 pcs</p>
<p>5</p> <p>2 pcs</p>	<p>6</p> <p>2 pcs</p>	<p>7</p> <p>2 pcs</p>	<p>8</p> <p>2 pcs</p>
<p>9</p> <p>2 pcs</p>	<p>10</p> <p>2 pcs</p>	<p>11</p> <p>4 pcs</p>	<p>12</p> <p>4 pcs</p>
<p>13</p> <p>2 pcs</p>	<p>14</p> <p>2 pcs</p>		

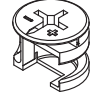
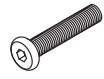

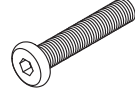
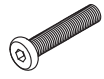
Hardware List

A	B	C	D	E	F	G
 M6x40mm	 Ø6x10mm	 Ø15x12mm	 Ø6x40mm	 8mm	 Ø6x50mm	 Ø6x30mm
26 pcs	24 pcs	26 pcs	40 pcs	4 pcs	28 pcs	12 pcs

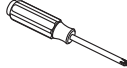
 M4						



Installation of Cams and Pins

Read each step carefully before starting. Each step of instruction should be performed in the correct order. If these steps are not followed in sequence, assembly difficulties may occur.

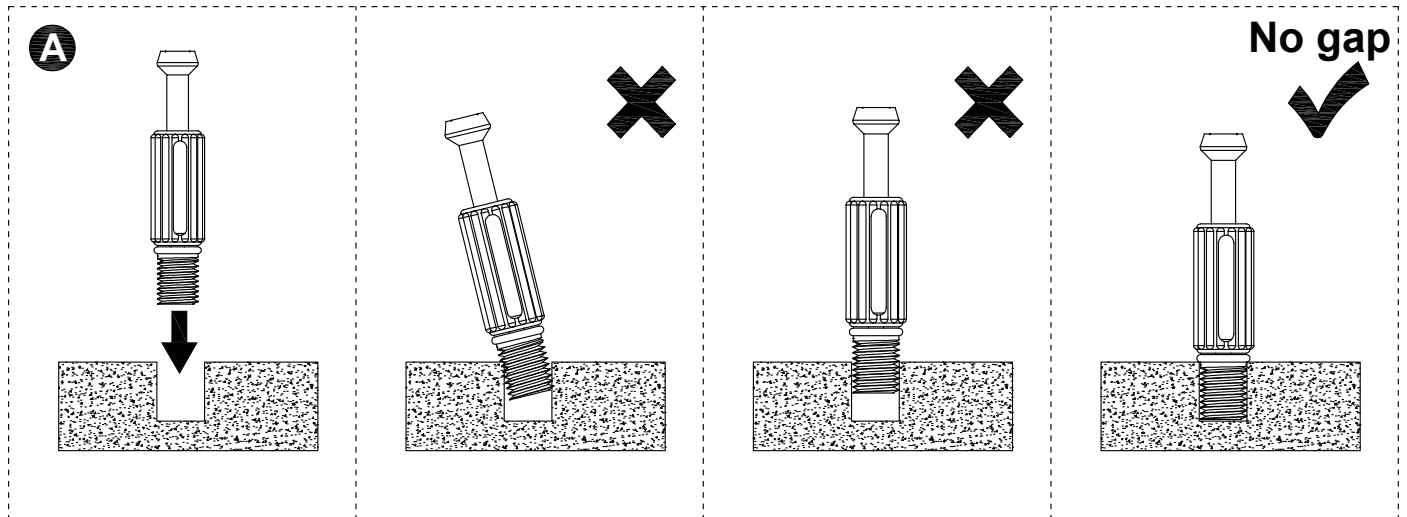

Screw the pin into the hole. Set the cams correctly by aligning the head of the cams with the lock pins. Lock the cam by turning the cam head with a screwdriver until it is tightened. Please do not use an electric screwdriver to assemble the unit.

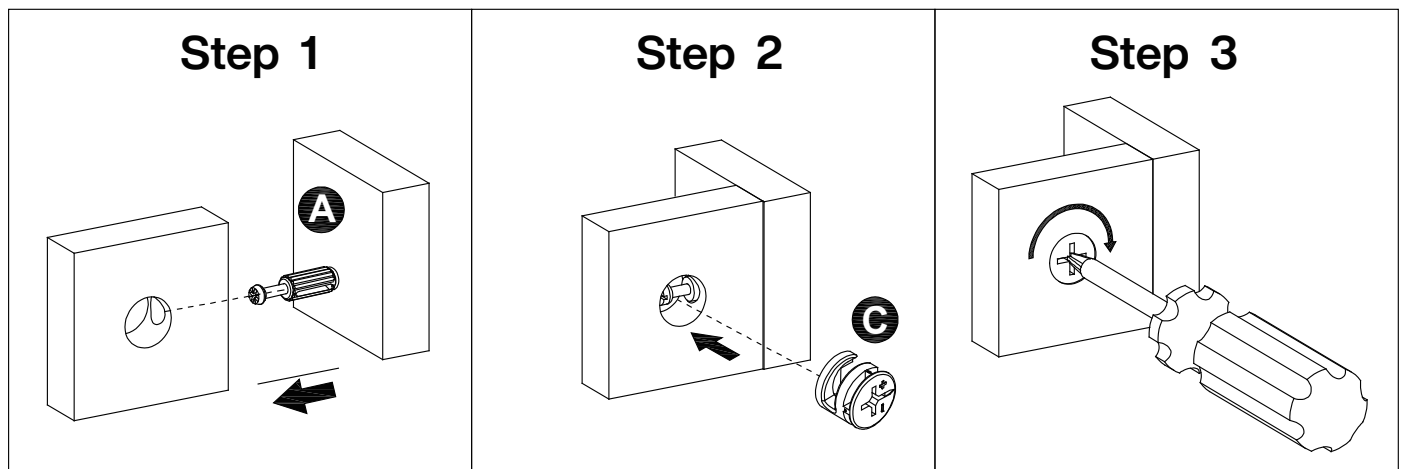

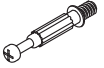

1

A

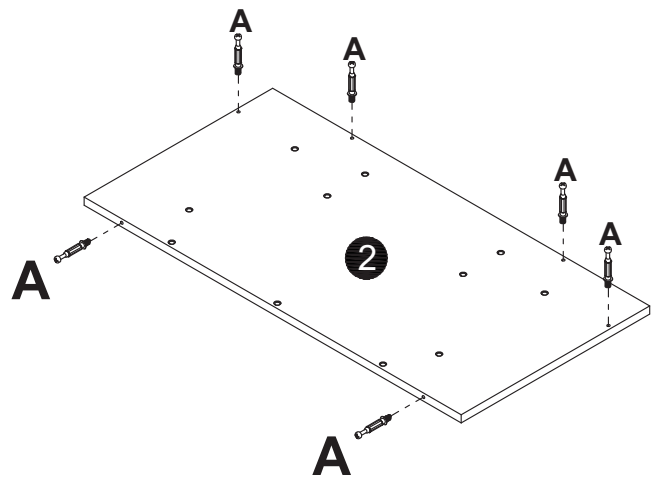
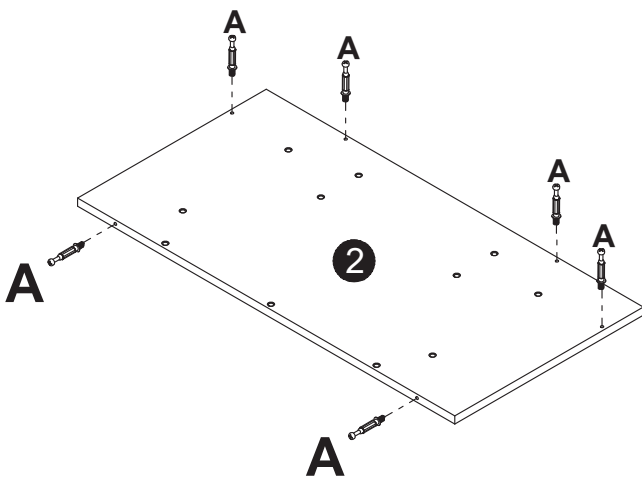
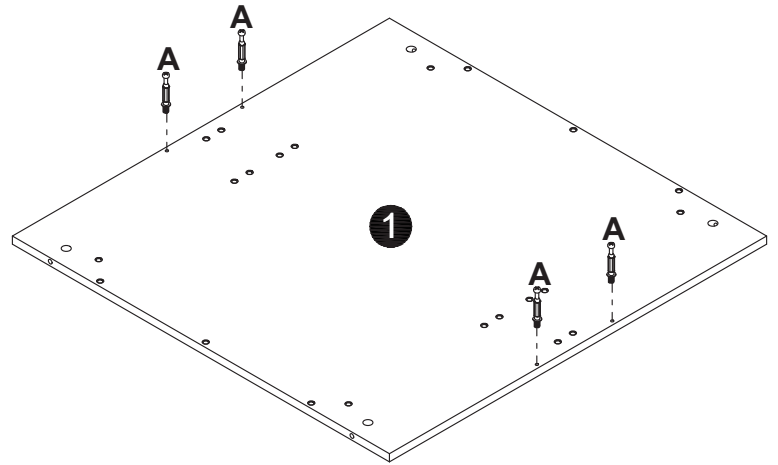
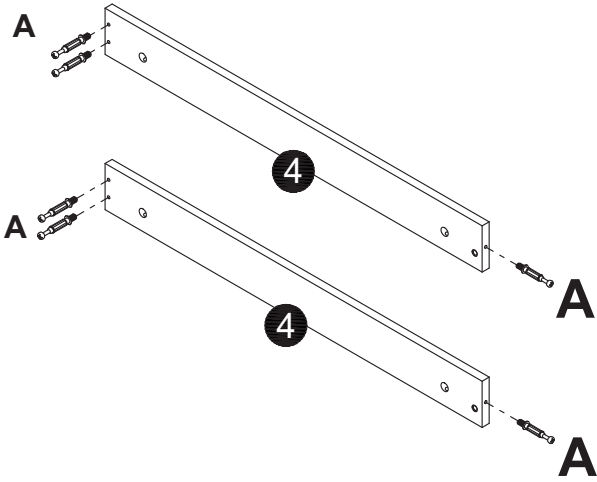
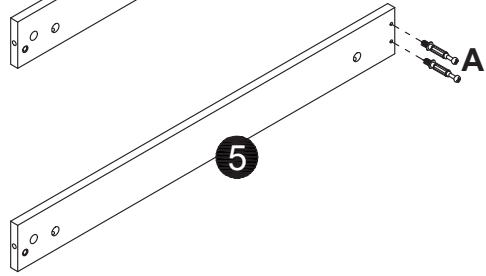
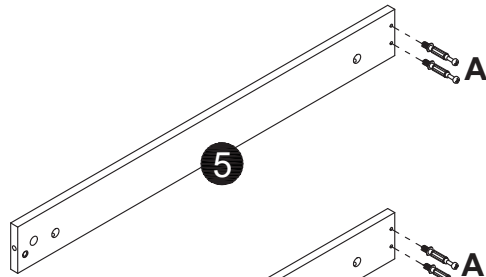
M6x40mm
26 pcs





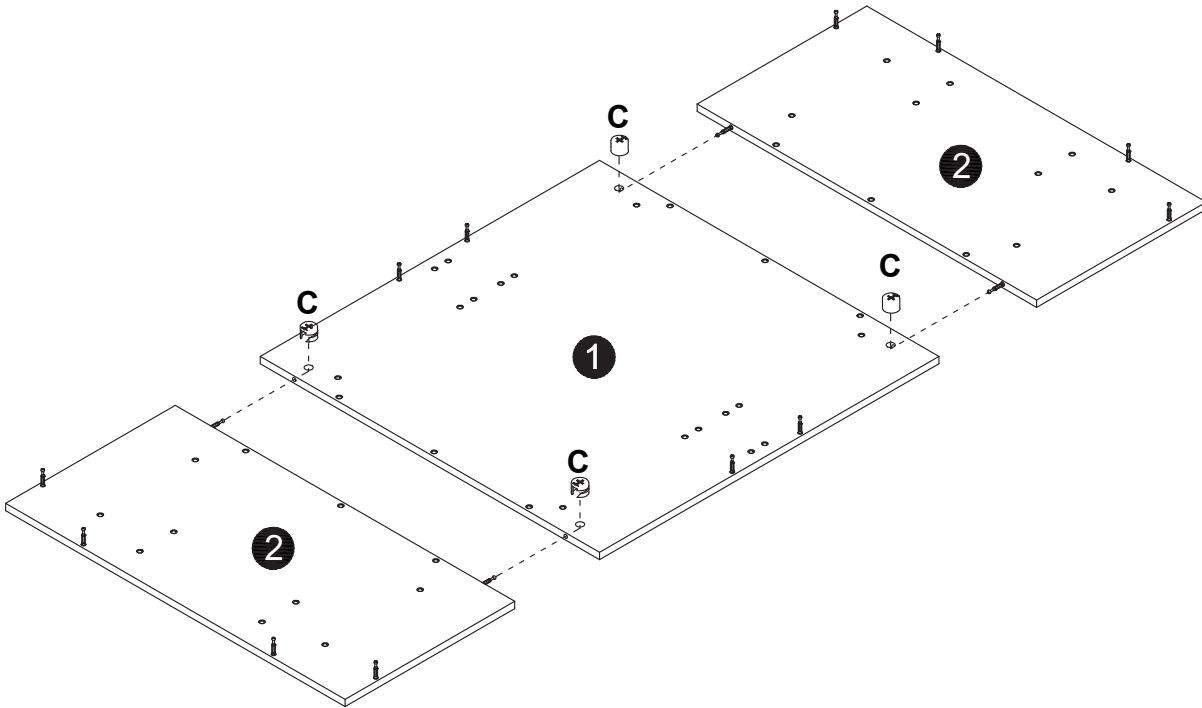

2

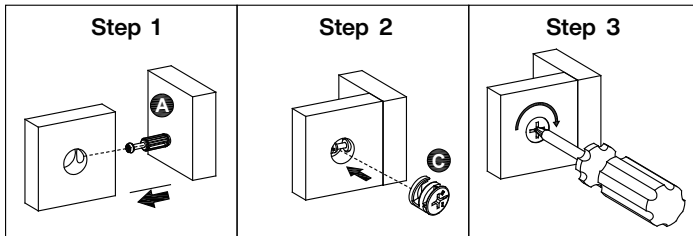

C

Ø15x12mm
4 pcs

3

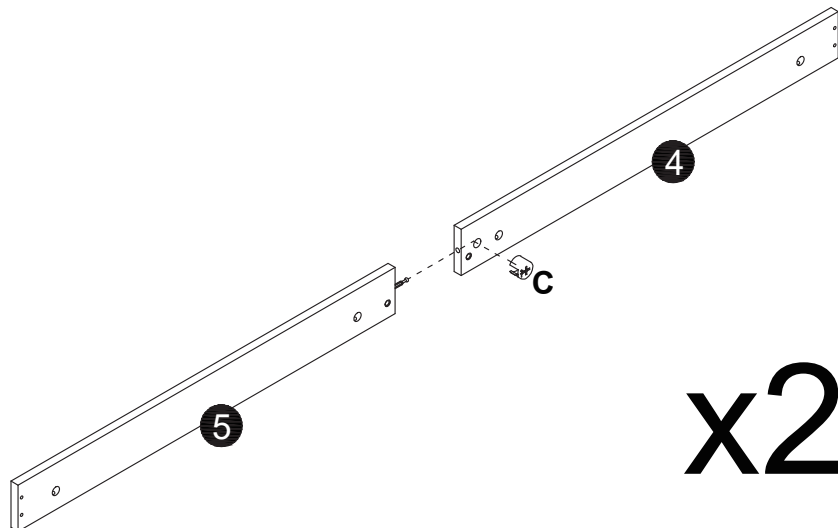

C

Ø15x12mm
2 pcs



x2

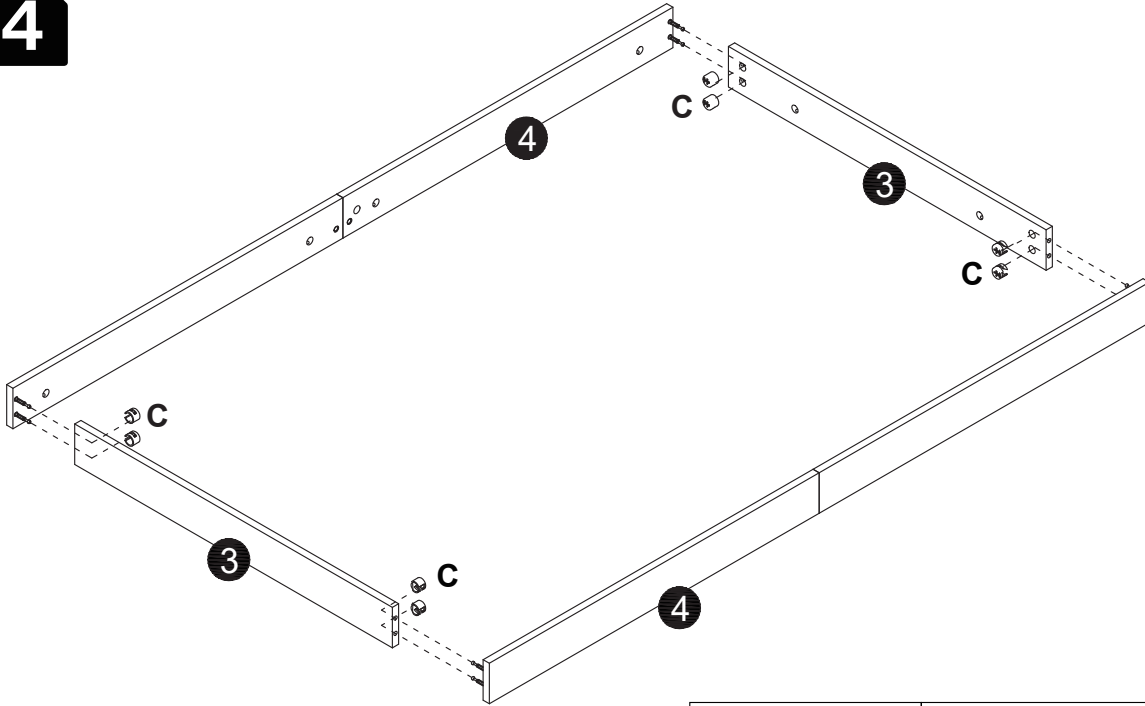

4

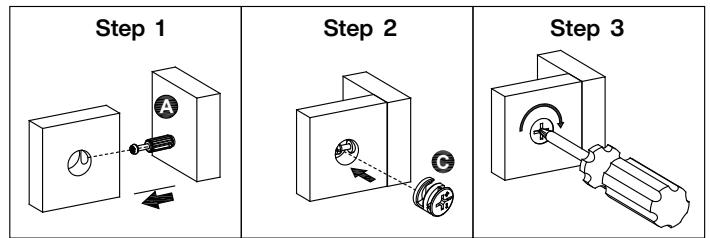

C

Ø15x12mm
8 pcs

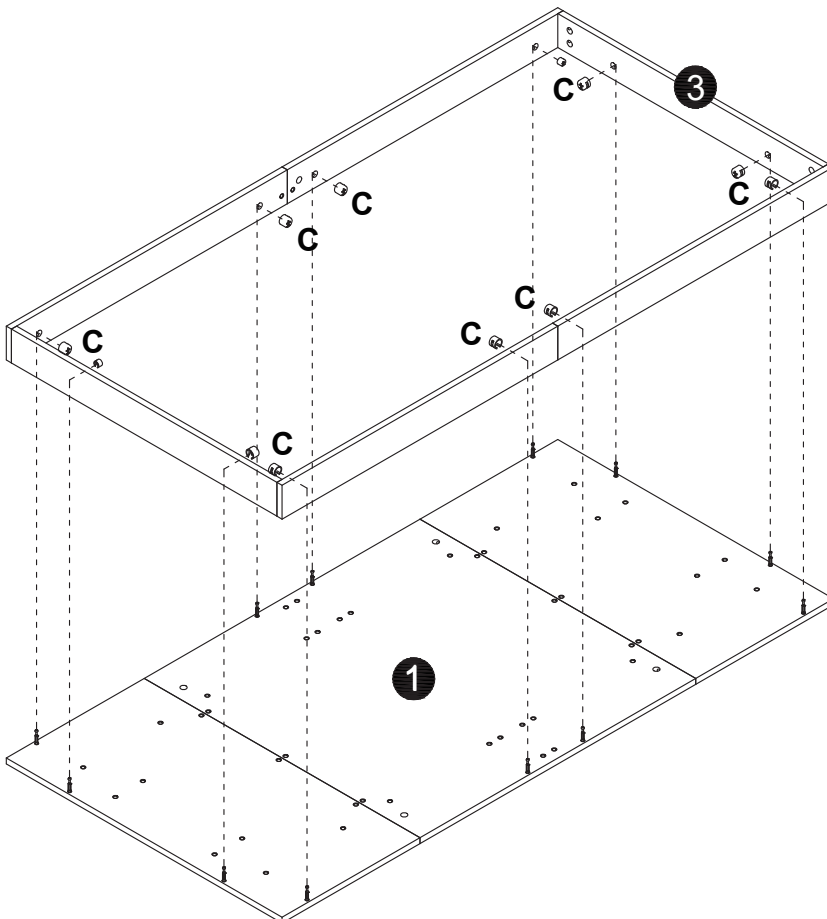

5



C

Ø15x12mm
12 pcs



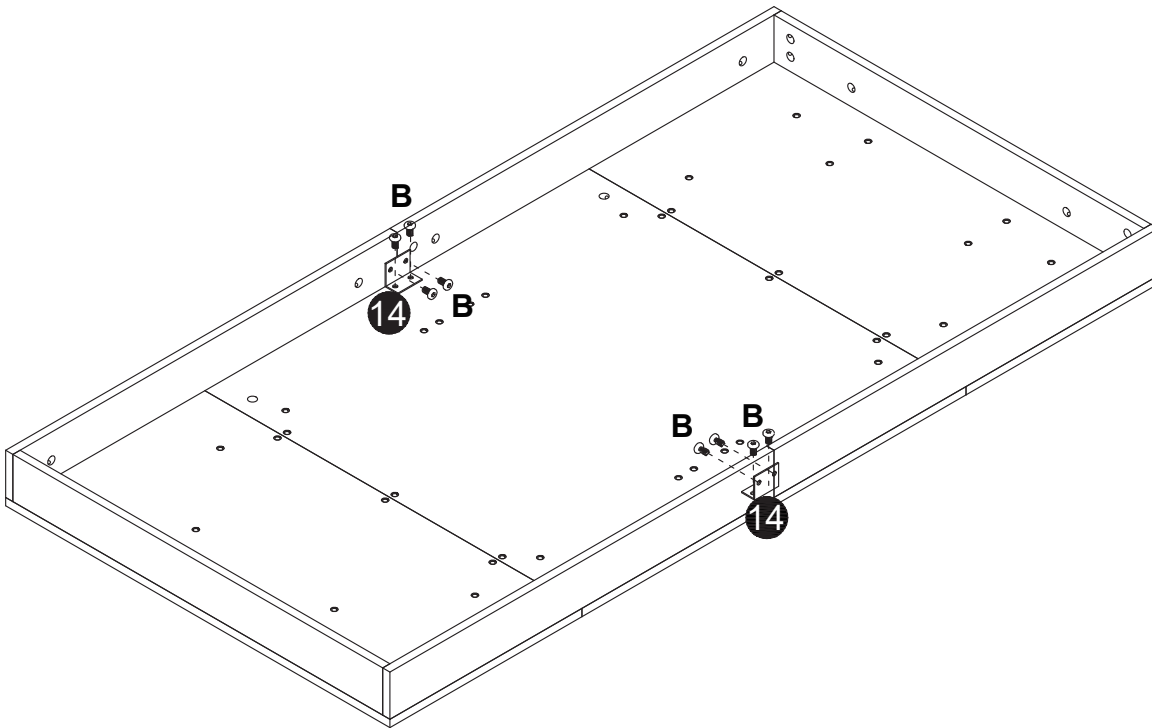

6

B

Ø6x10mm
8 pcs

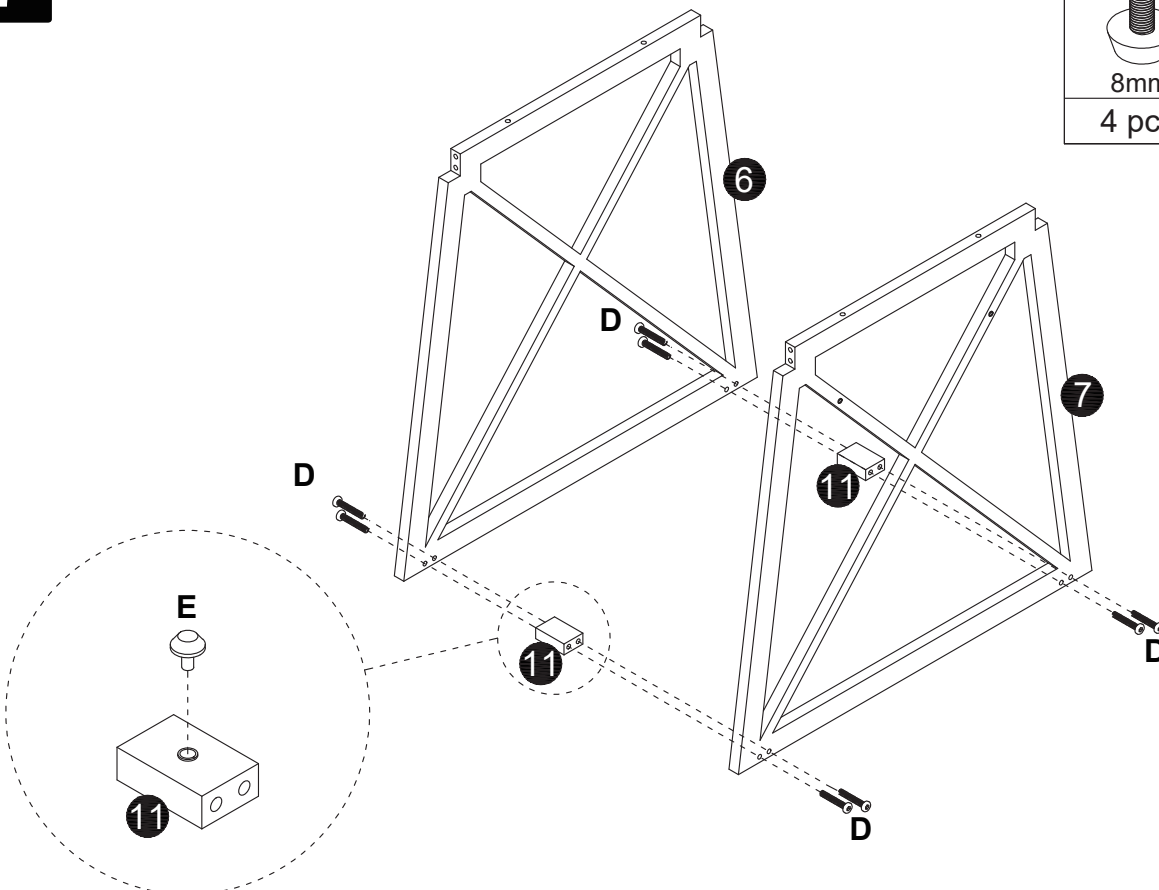

7

E	D
	
8mm	Ø6x40mm
4 pcs	16 pcs



x2



8

B

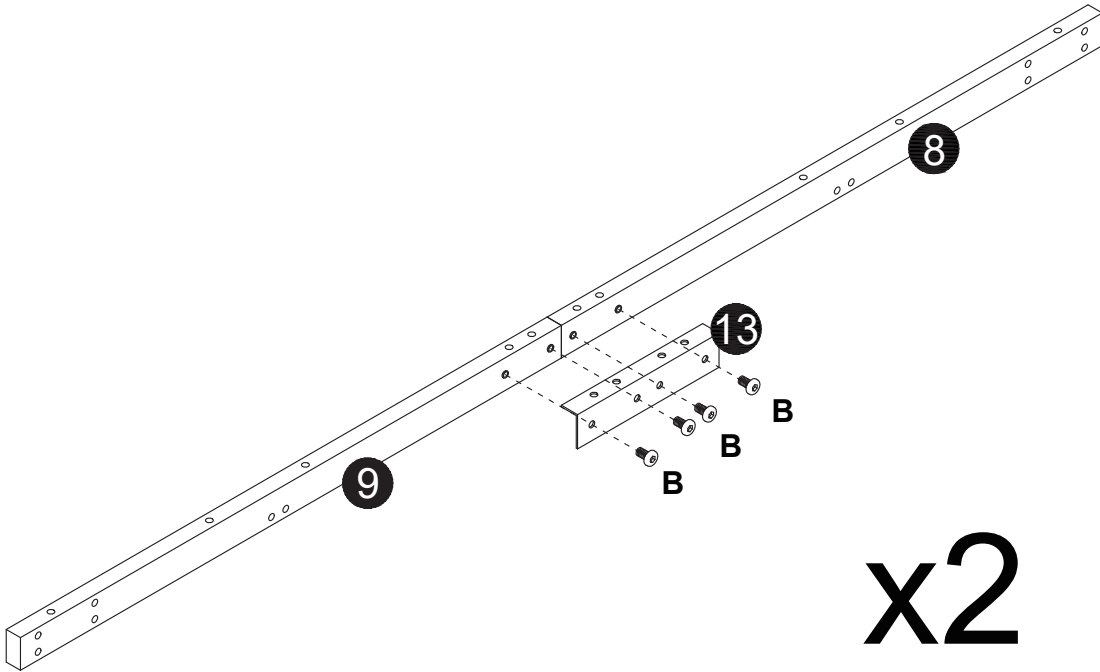
Ø6x10mm
8 pcs

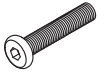

9

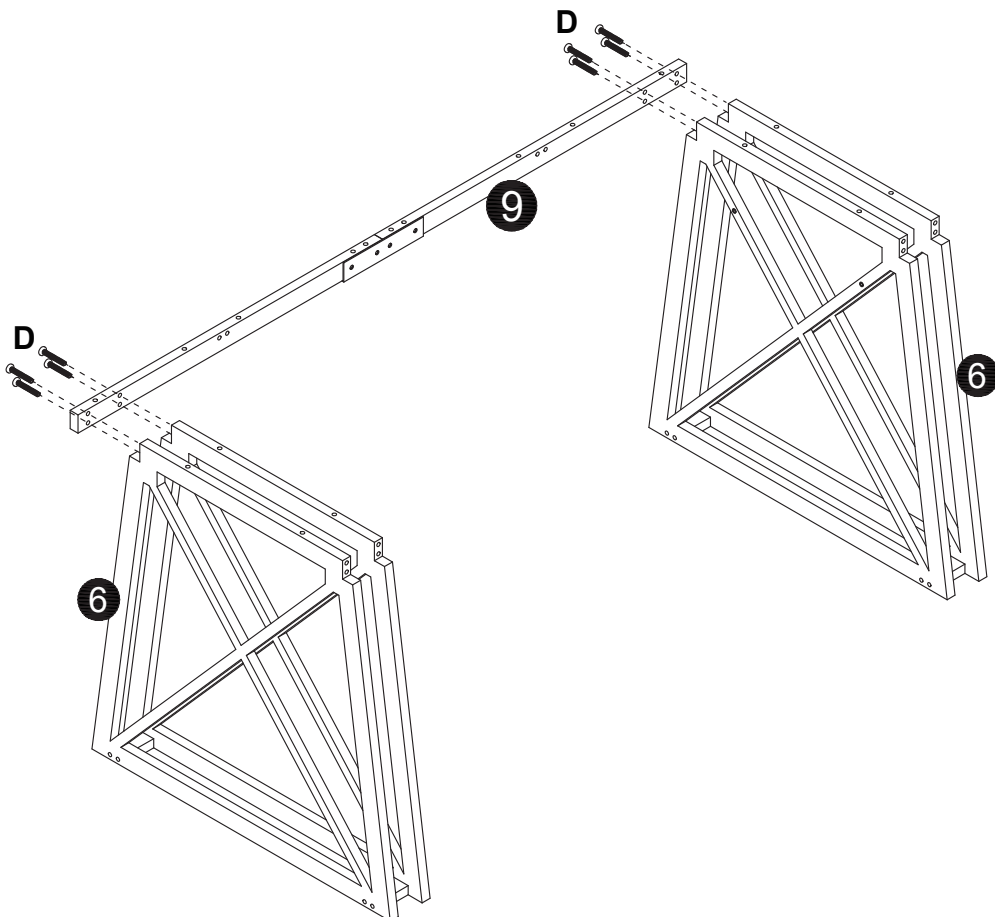
D

Ø6x40mm
8 pcs





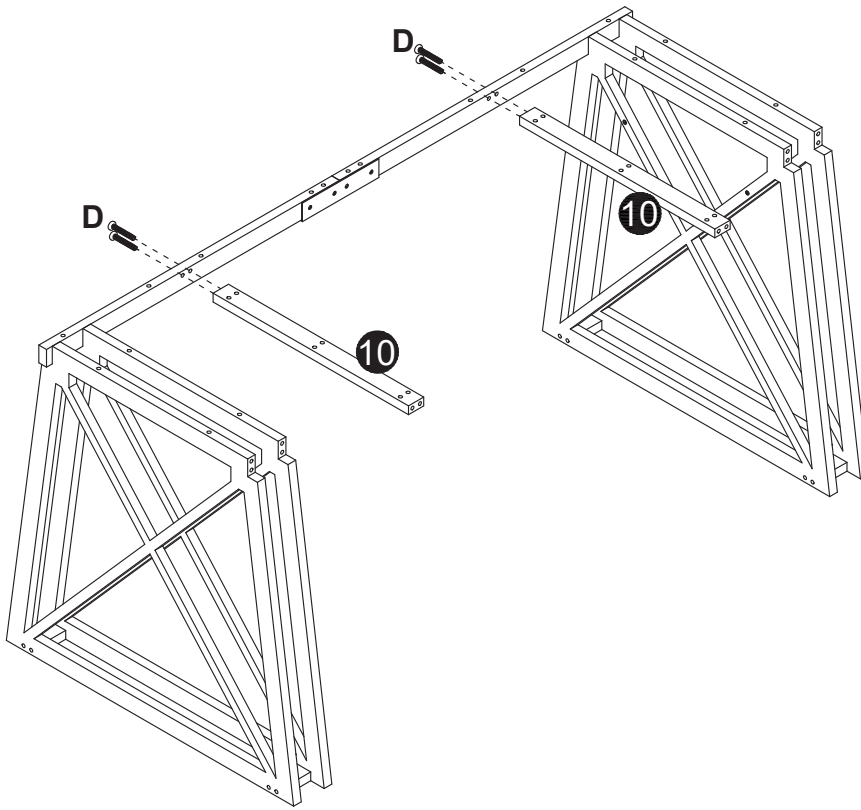

10

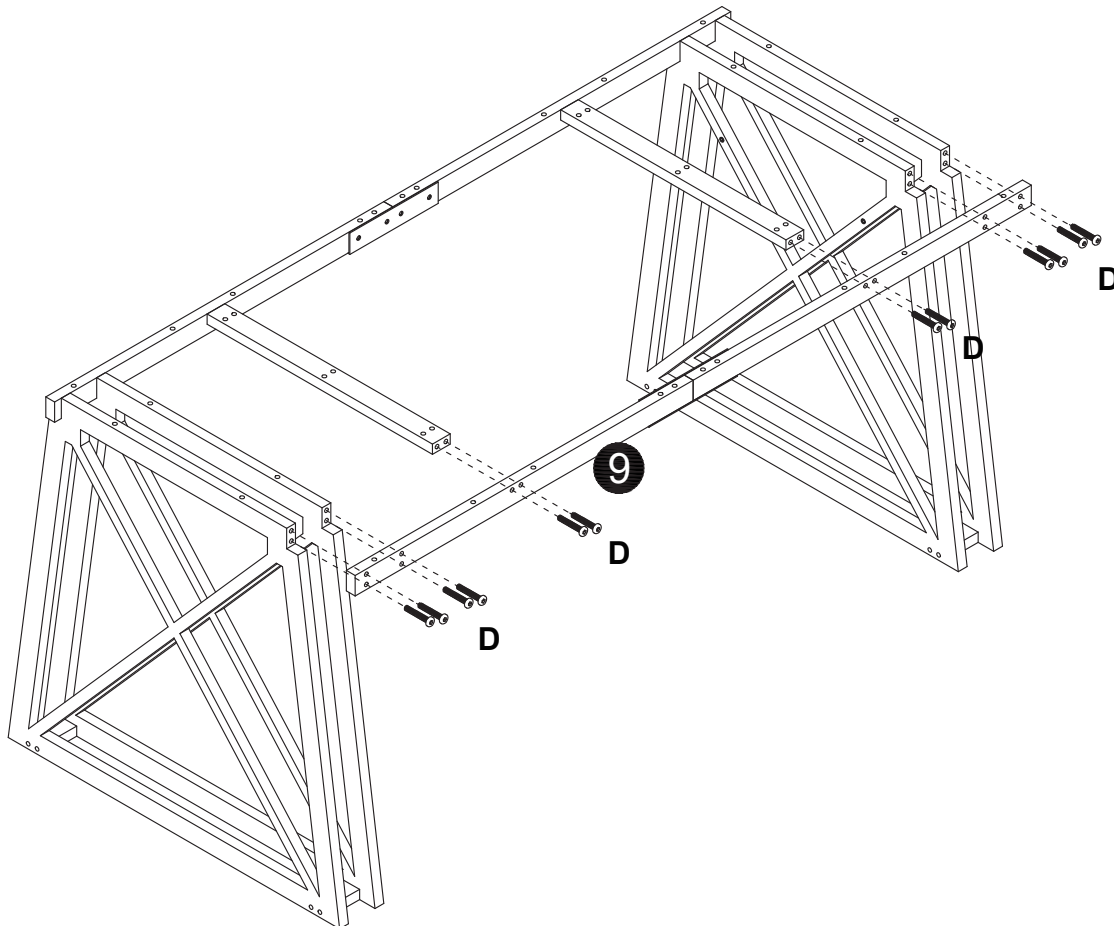

D

Ø6x40mm
4 pcs

11



D

Ø6x40mm
12 pcs



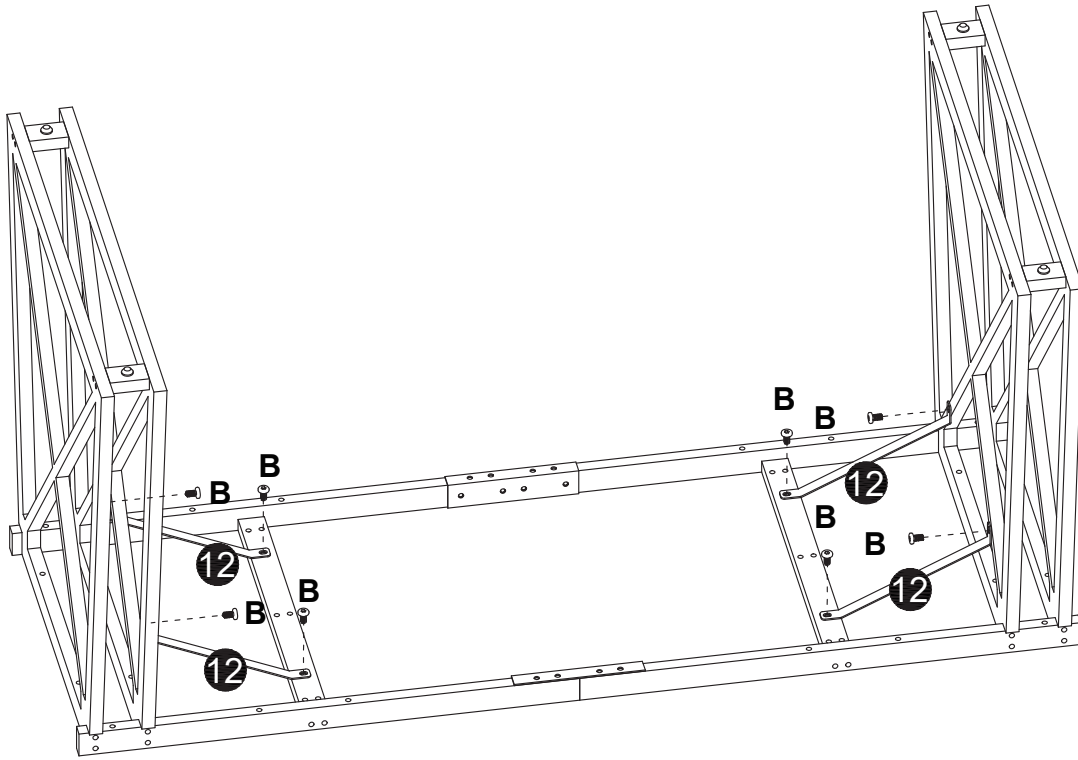

12

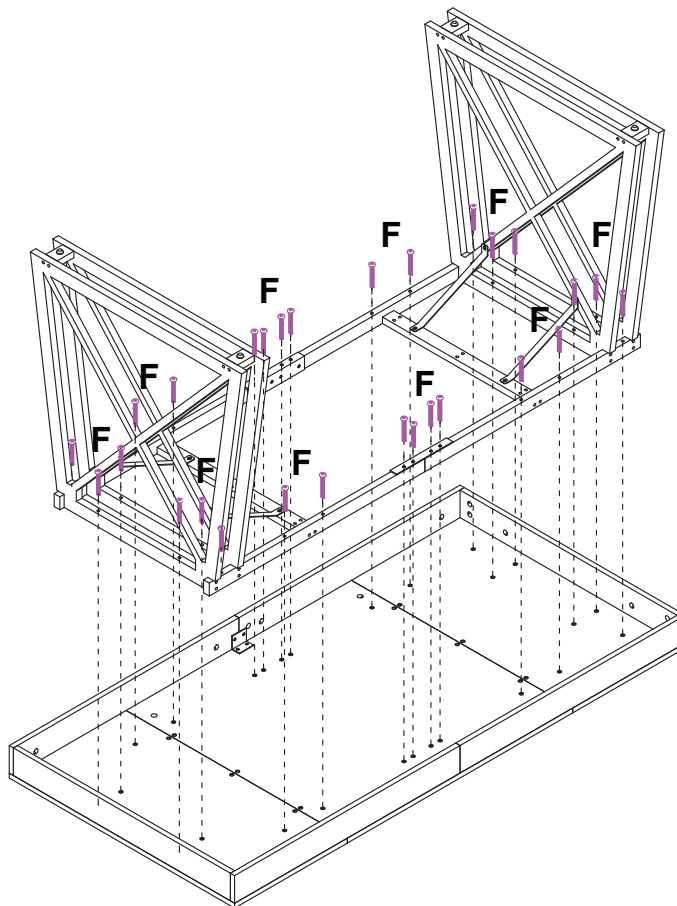

B

Ø6x10mm
8 pcs

13



F

Ø6x50mm
28 pcs

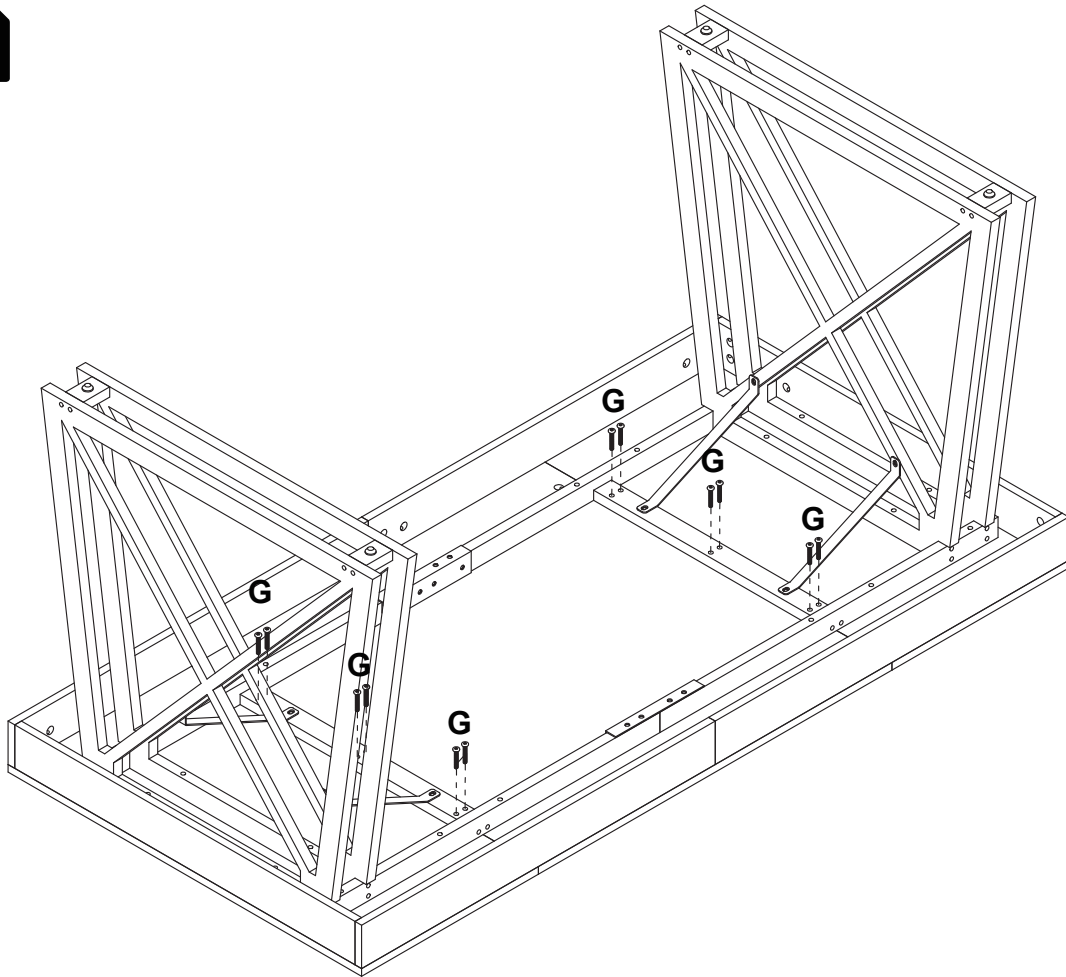

14



G

Ø6x30mm
12 pcs

15

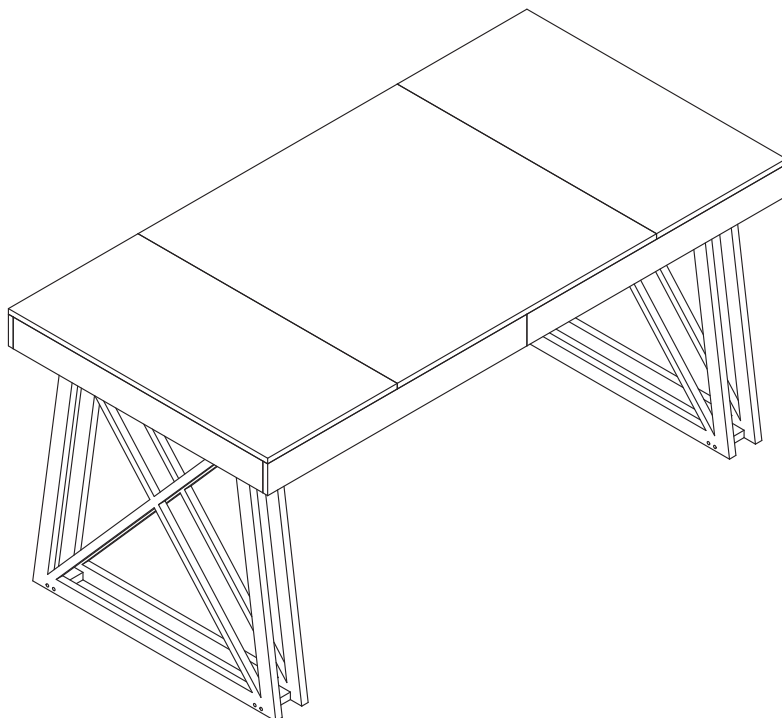



DESIGNED FOR LIFE

Thank you for your support!

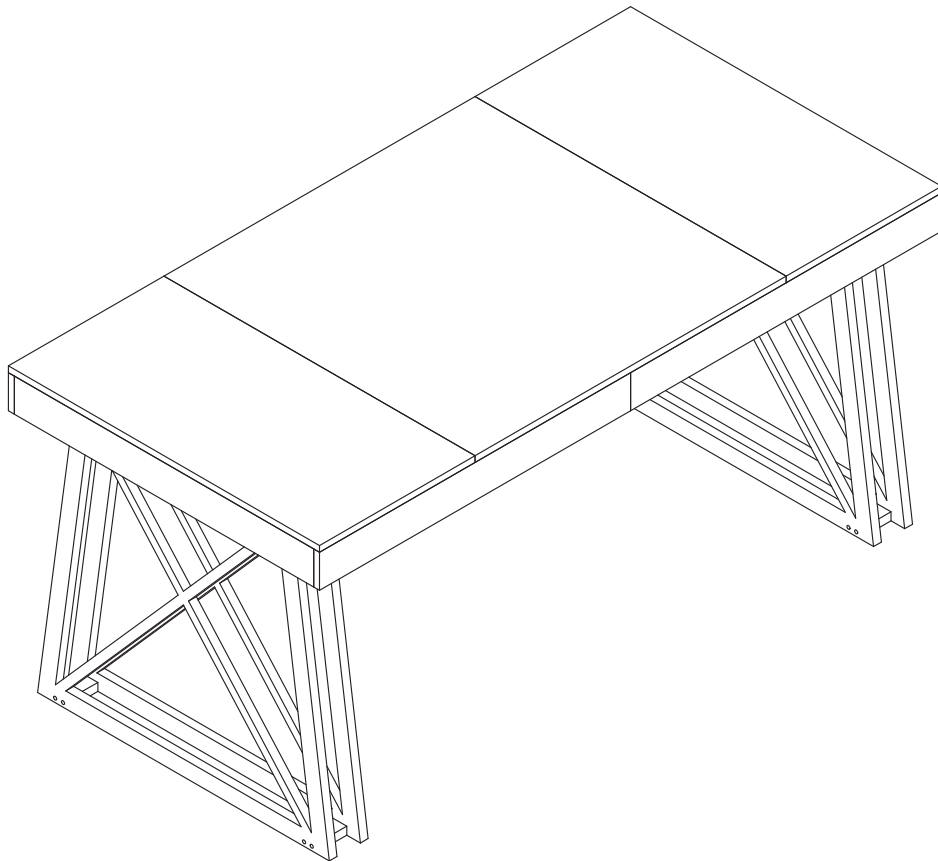

Contact our customer service team



support@tribesigns.com
www.tribesigns.com



1-424-220-6888

7 AM to 8 PM EST,
Monday to Friday

Follow Tribesigns



Facebook



Instagram



Pinterest



Twitter



YouTube



TikTok



WhatsApp