

SKU:LI007901

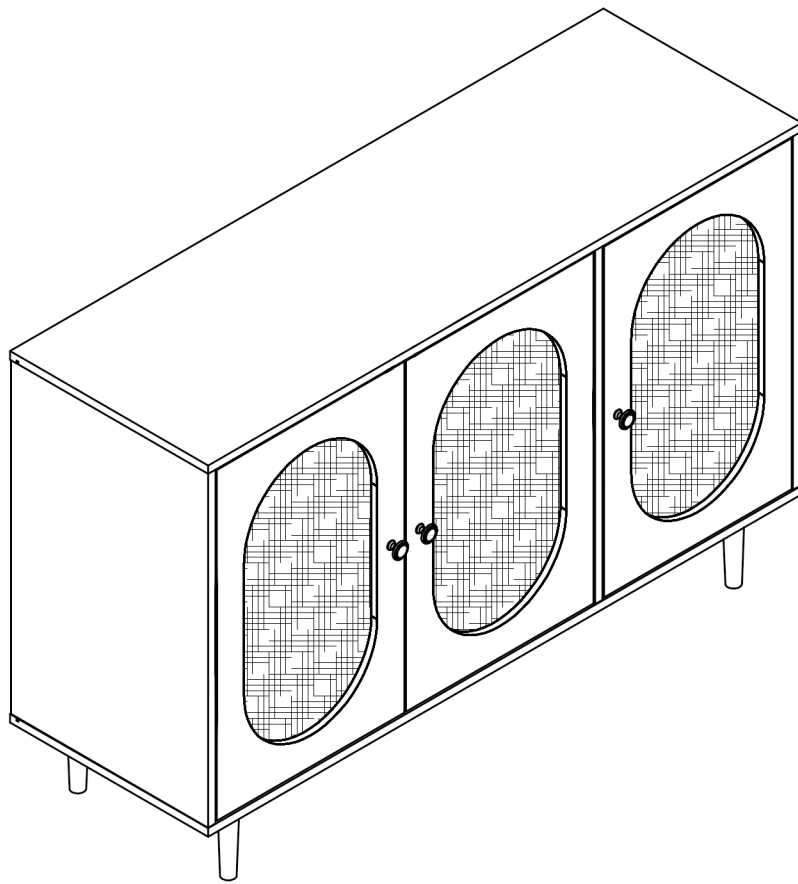

Board Identification

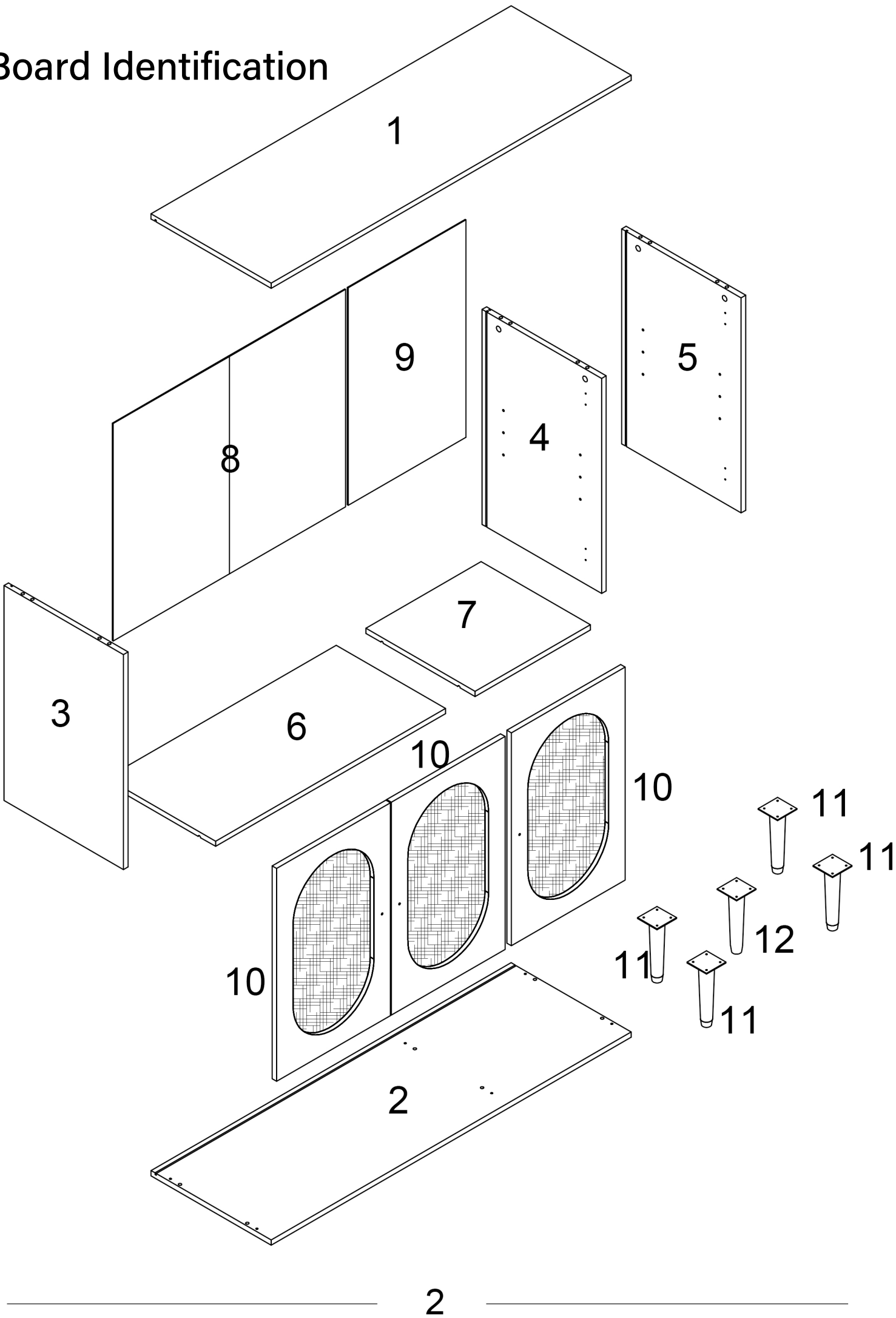

Parts List

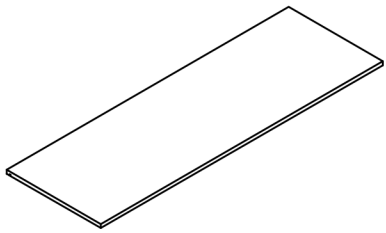

1

1PC

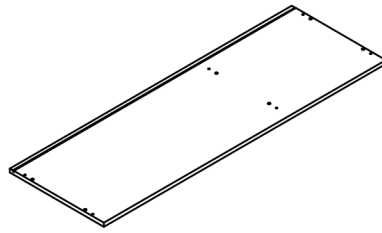

2

1PC

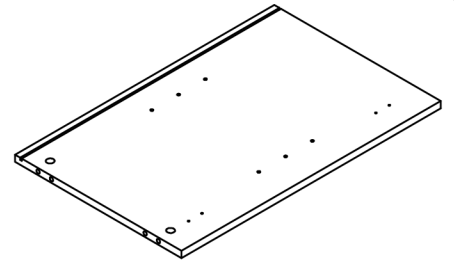

3

1PC

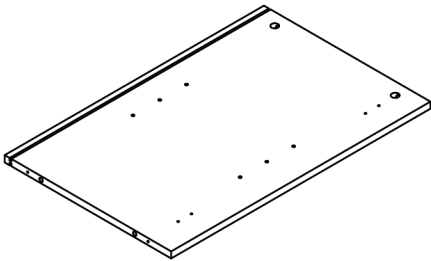

4

1PC

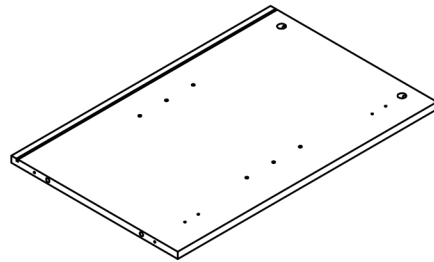

5

1PC

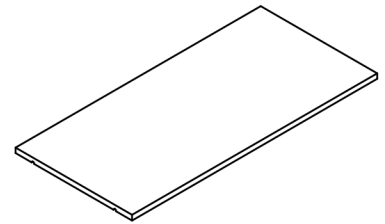

6

1PC

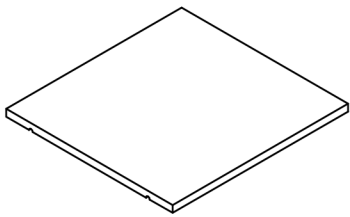

7

1PC

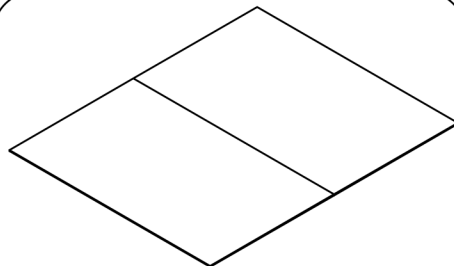

8

1PC

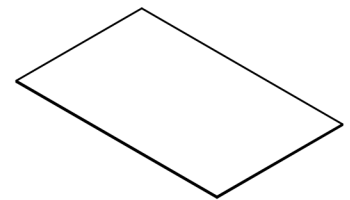

9

1PC

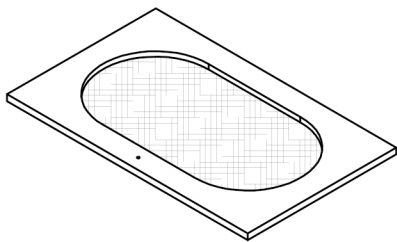

10

3PC

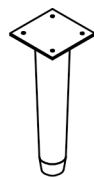

11

4PC

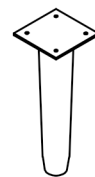

12

1PC

Hardware List



A

6PC

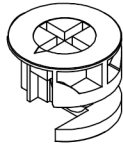

Ø15

B

6PC



Ø8*30mm

C

12PC

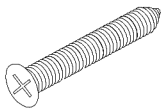

Ø4*40mm

D

6PC



E

3PC



M4*18mm

F

3PC



Ø3.5*14mm

G

24PC



H

6PC

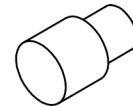

I

8PC



Ø4*14mm

J

20PC

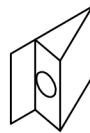

K

8PC



Ø3*14mm

L

8PC

STEP 1

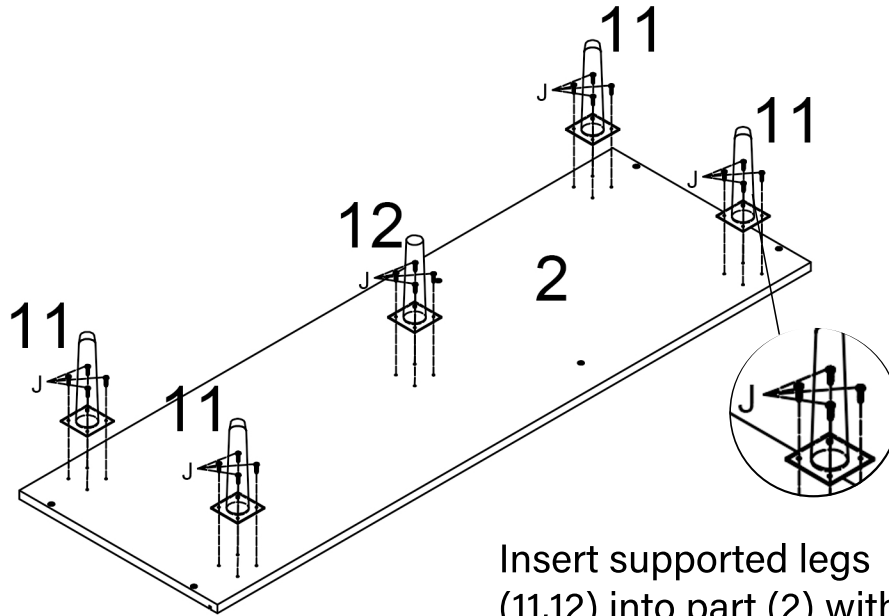
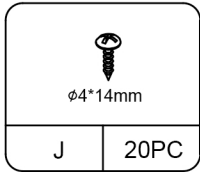

Insert supported legs (11,12) into part (2) with screw (J) .

STEP 2

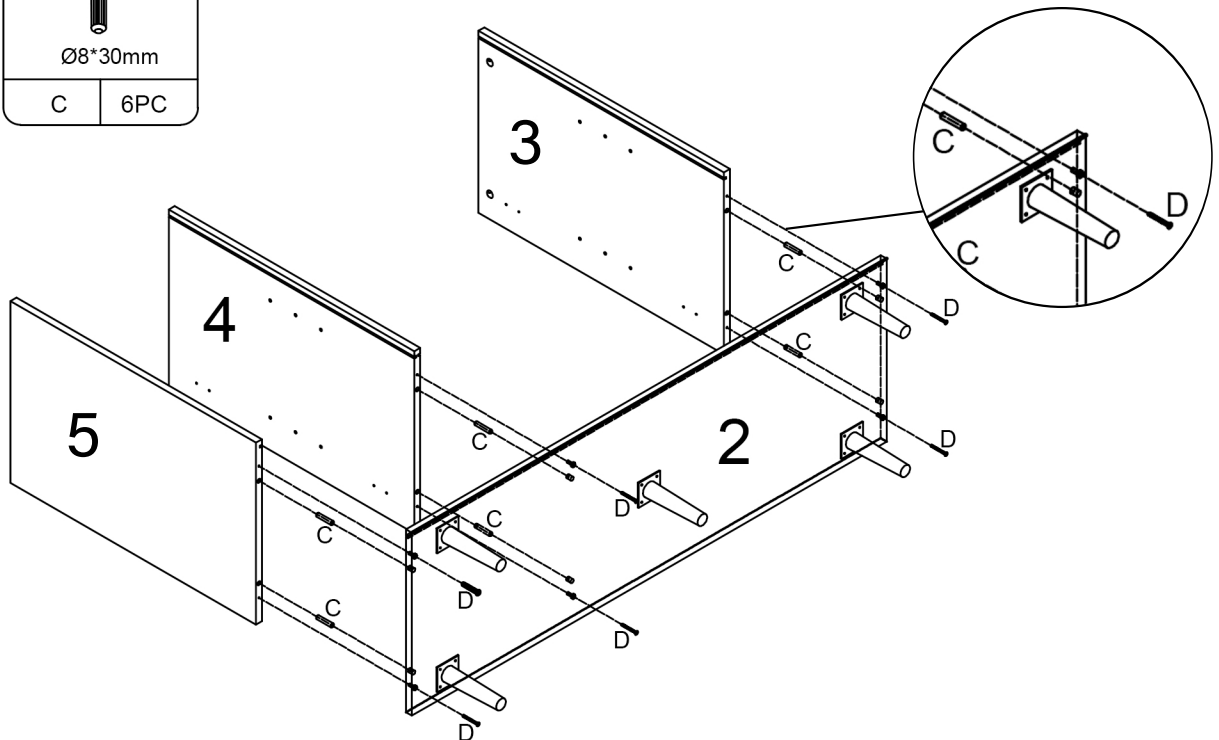
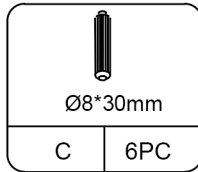
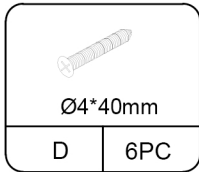

Insert wooden dowel (C) into part (2) . Attach part (3,4,5) to part (2) with screw (D) .

STEP 3

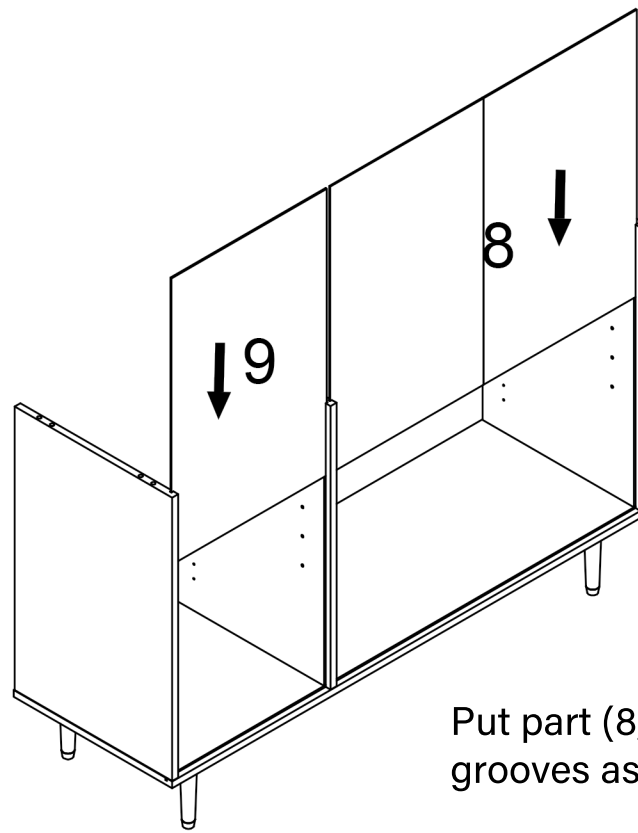

Put part (8,9) into grooves as per diagram.

STEP 4

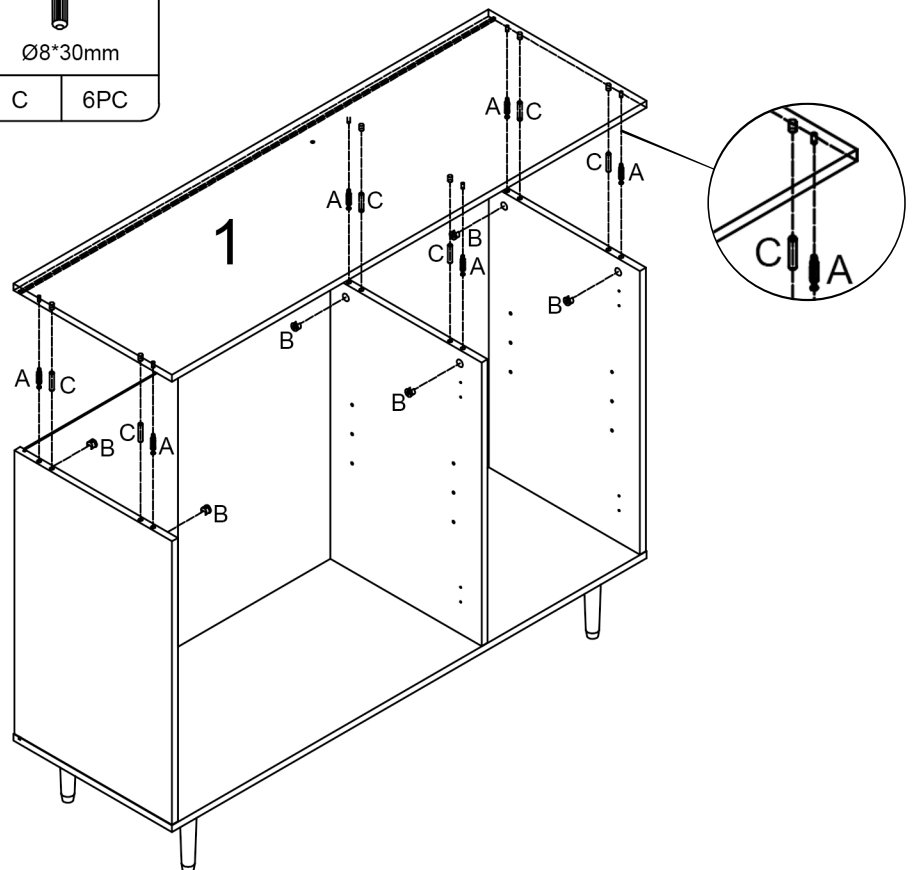
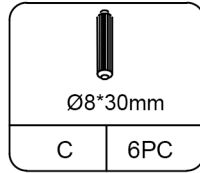
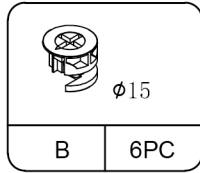
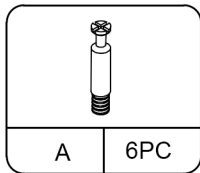

Insert wooden dowel (C) and cam bolt (A) into part (1) with screwdriver. Attach part (1) to other parts, then insert and secure cam lock (B).

STEP 5

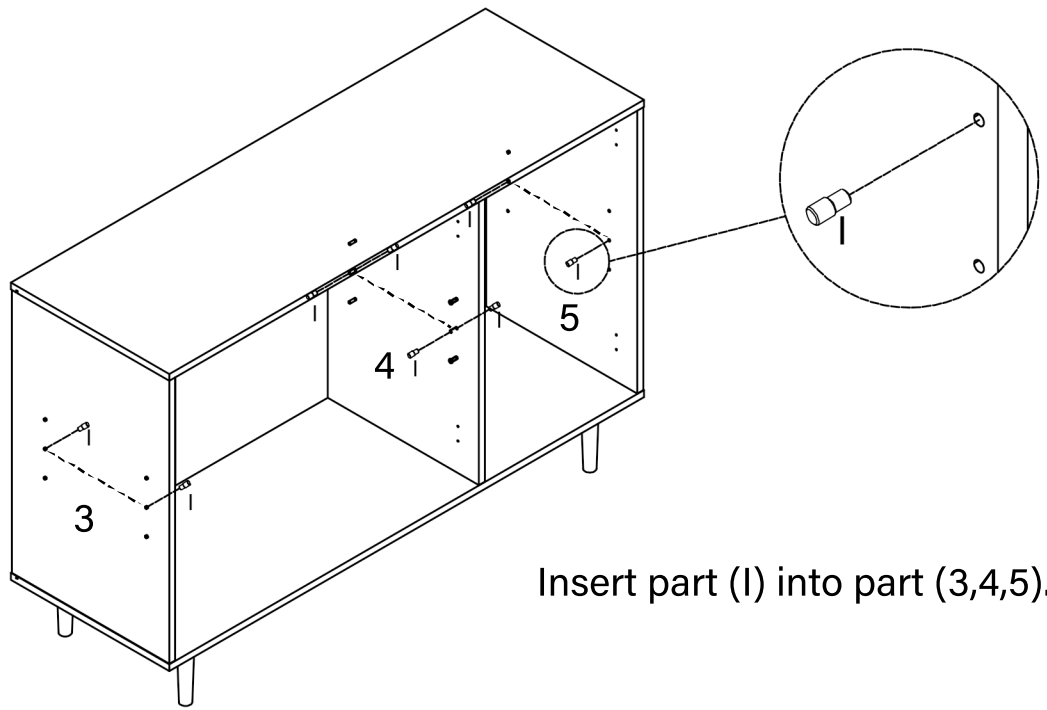
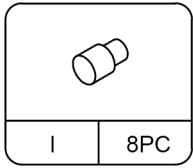

Insert part (I) into part (3,4,5).

STEP 6

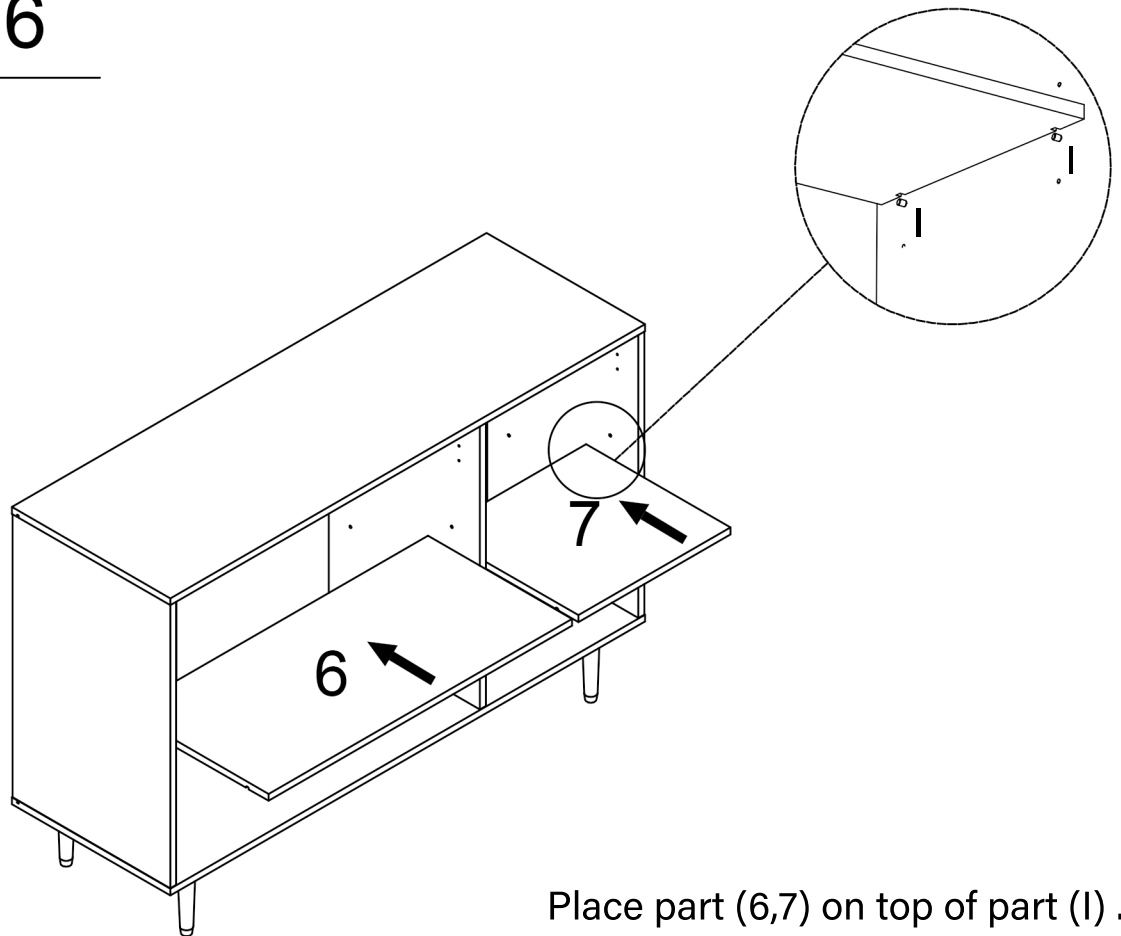
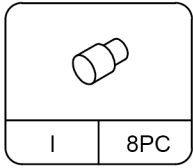

Place part (6,7) on top of part (I) .

STEP 7

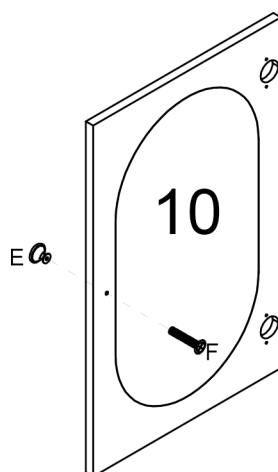
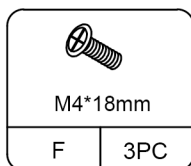
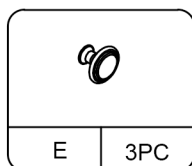

x3PC

Using screw (F),attach part (E) to part (10).

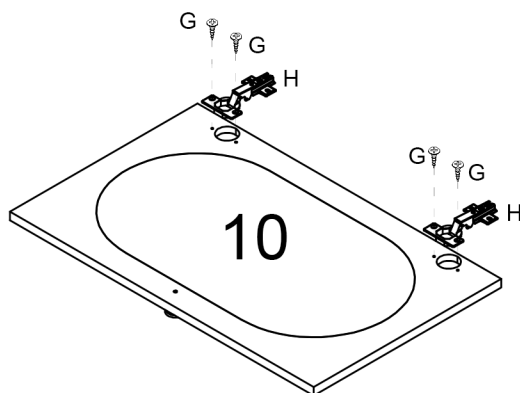
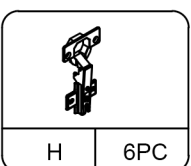
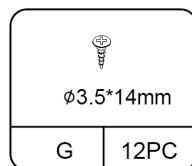

STEP 8



x3PC

Using screw (G),attach part (H) to part (10).

STEP 9

 Ø3.5*14mm			
G	12PC	H	6PC

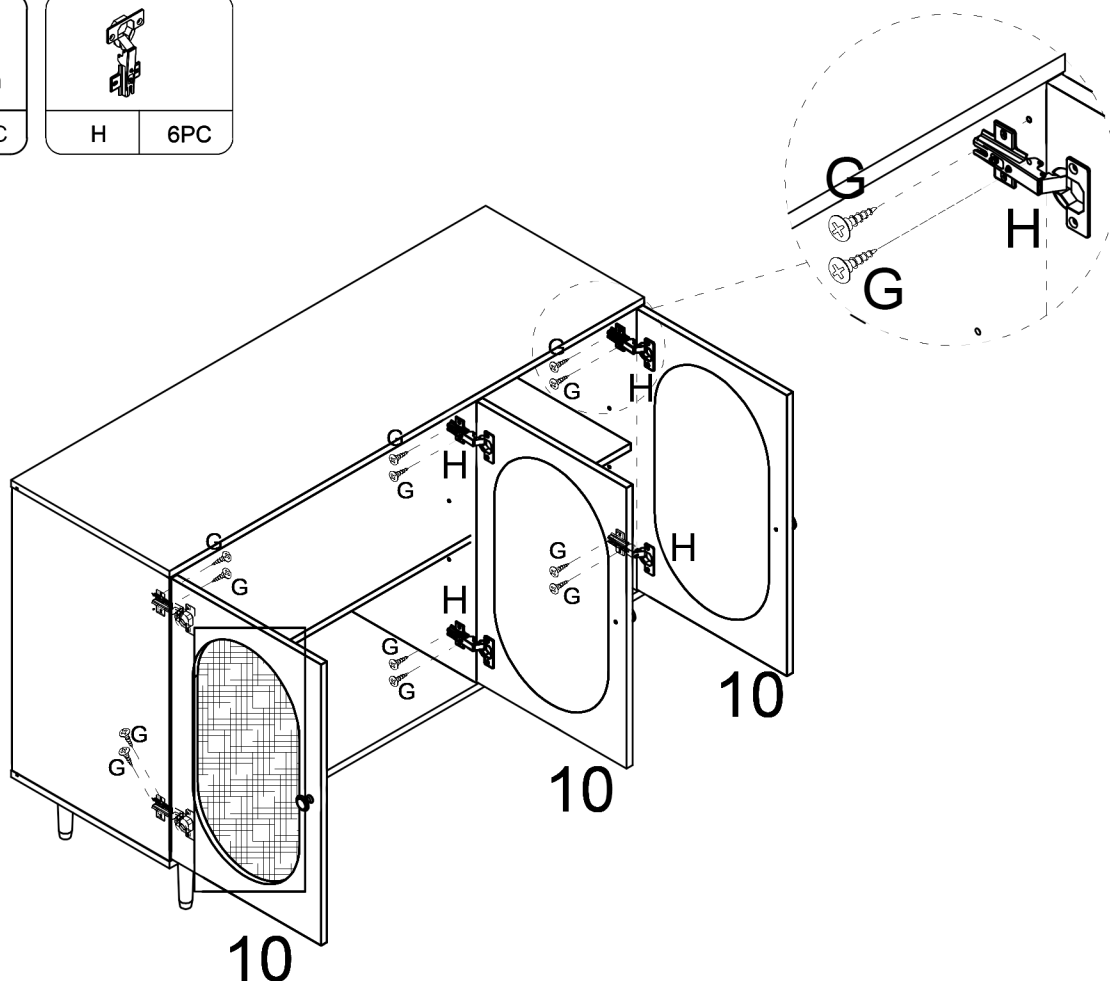

Using screw (G) , assemble all doors and other parts assembled.

Part (H) is adjustable. If you want to watch the assembly video in this section, it is presented on the product link.

STEP 10

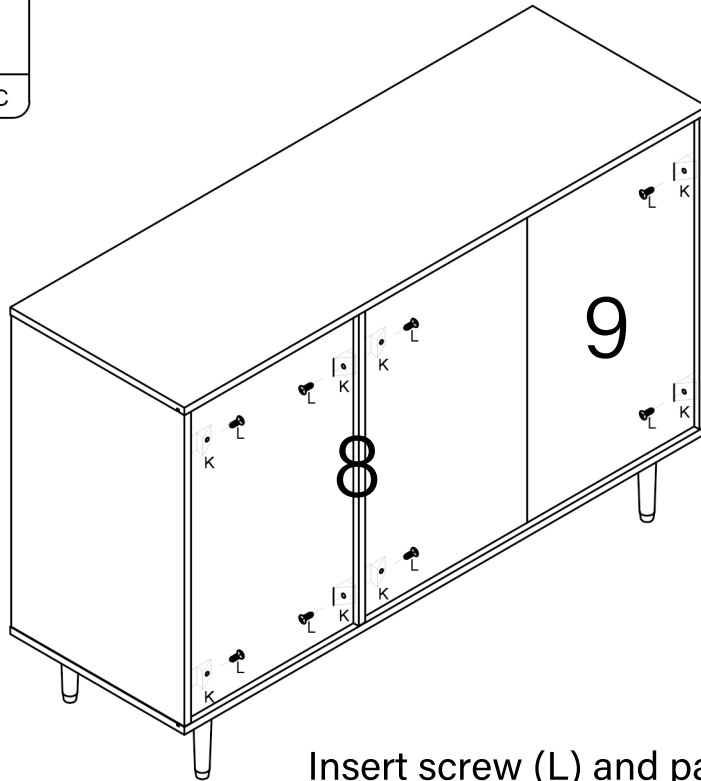
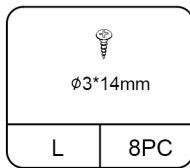
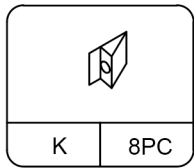

Insert screw (L) and part (K) into part (8,9).

STEP 11

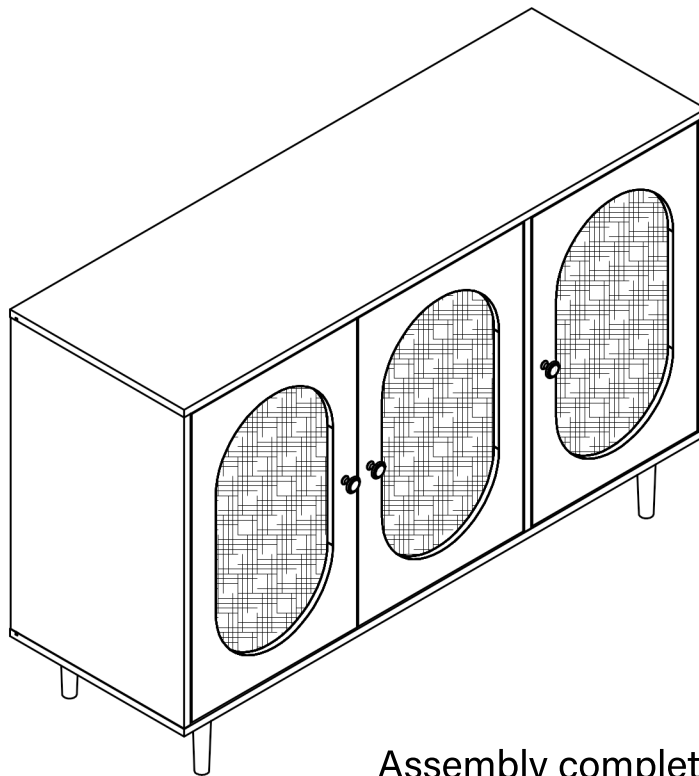

Assembly complete.

SPECIAL VERSION

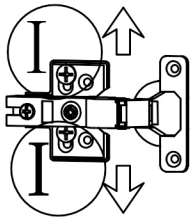

For specific adjustment details, please carefully read the precautions on the last page!

I: Adjust the screws at I to move the hinge up and down to adjust the up and down position of the door panel.

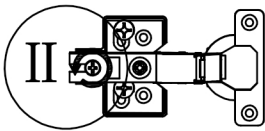

II: Adjust the screws at II to adjust the distance between the door panel and the vertical panel.

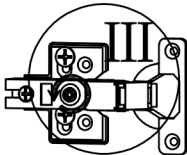

III: Adjust the screws at III to adjust the distance between the door panels.

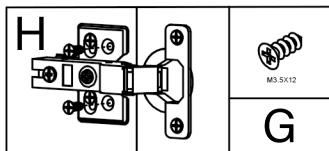

Combine the Part H with the each door panel by placing Part G screws after complete steps I, II and III.