

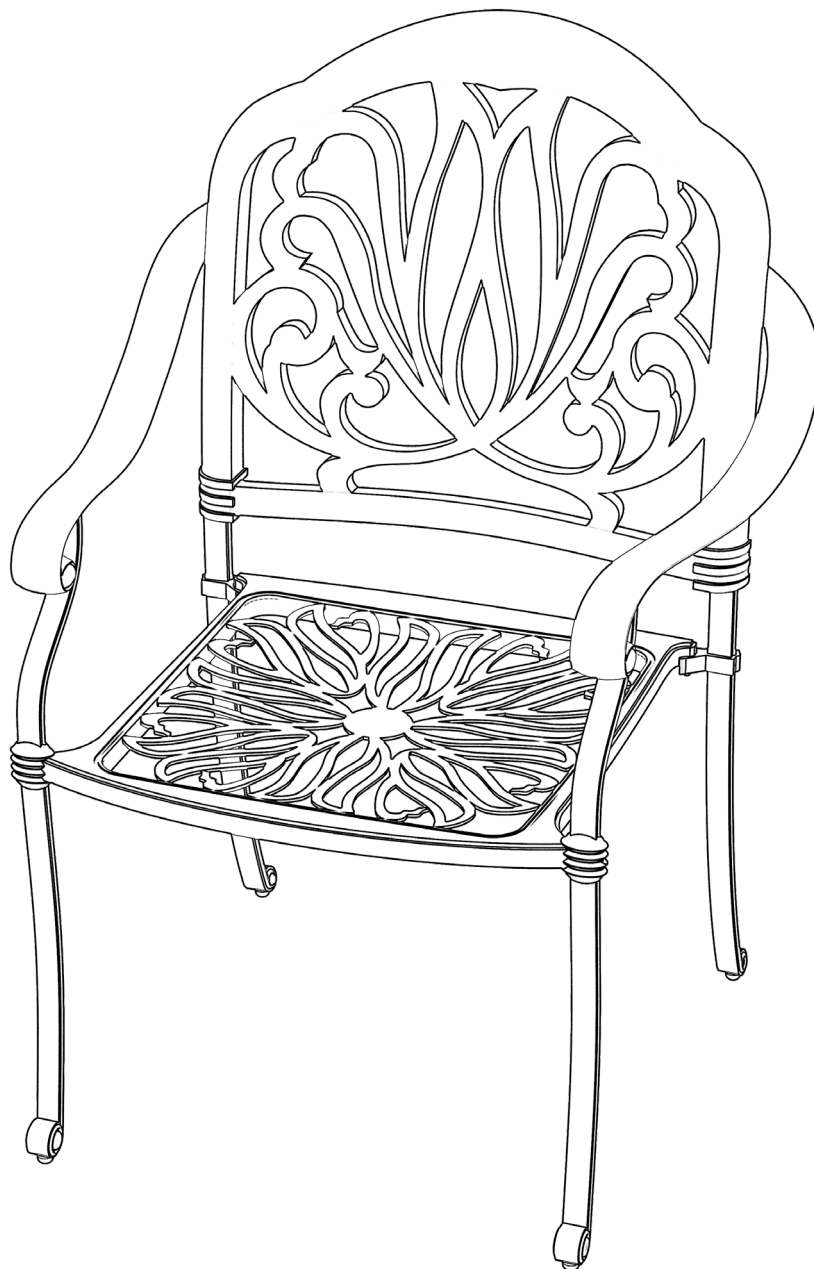

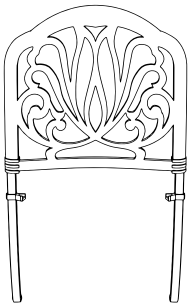

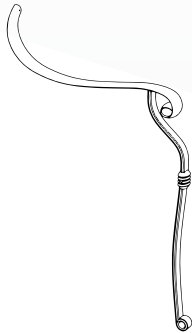

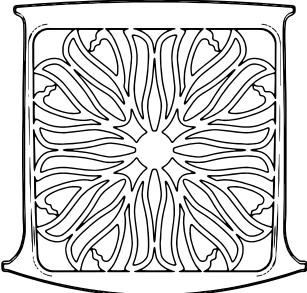
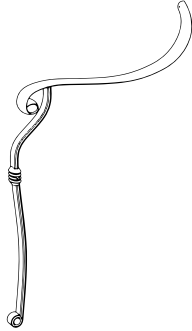

# Cast Aluminum Dining Armchair

## Operating instruction

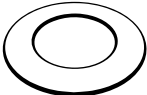
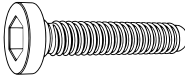

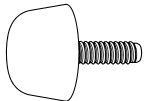
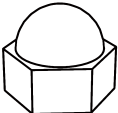
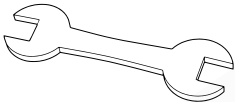
Attention: This shed was shipped in 1 box. contains all accessories. If you have any questions after receiving the shed.  
Please contact us in time and provide pictures if necessary. we will try our best to help you solve it.

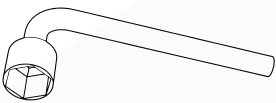
Part	Description	Qty	Part	Description	Qty
A		2 pcs	C	 Right	2 pcs
B		2 pcs	D	 Left	2 pcs

Part	Description	Qty	Part	Description	Qty
1	 M8x35mm	4 pcs	5	 M8x30mm	4 pcs
2	 M8	8 pcs	6	 M8x45mm	4 pcs
3		8 pcs	7		8 pcs
4		8 pcs			
					
					

One extra for each accessory for later maintenance

# Step 1

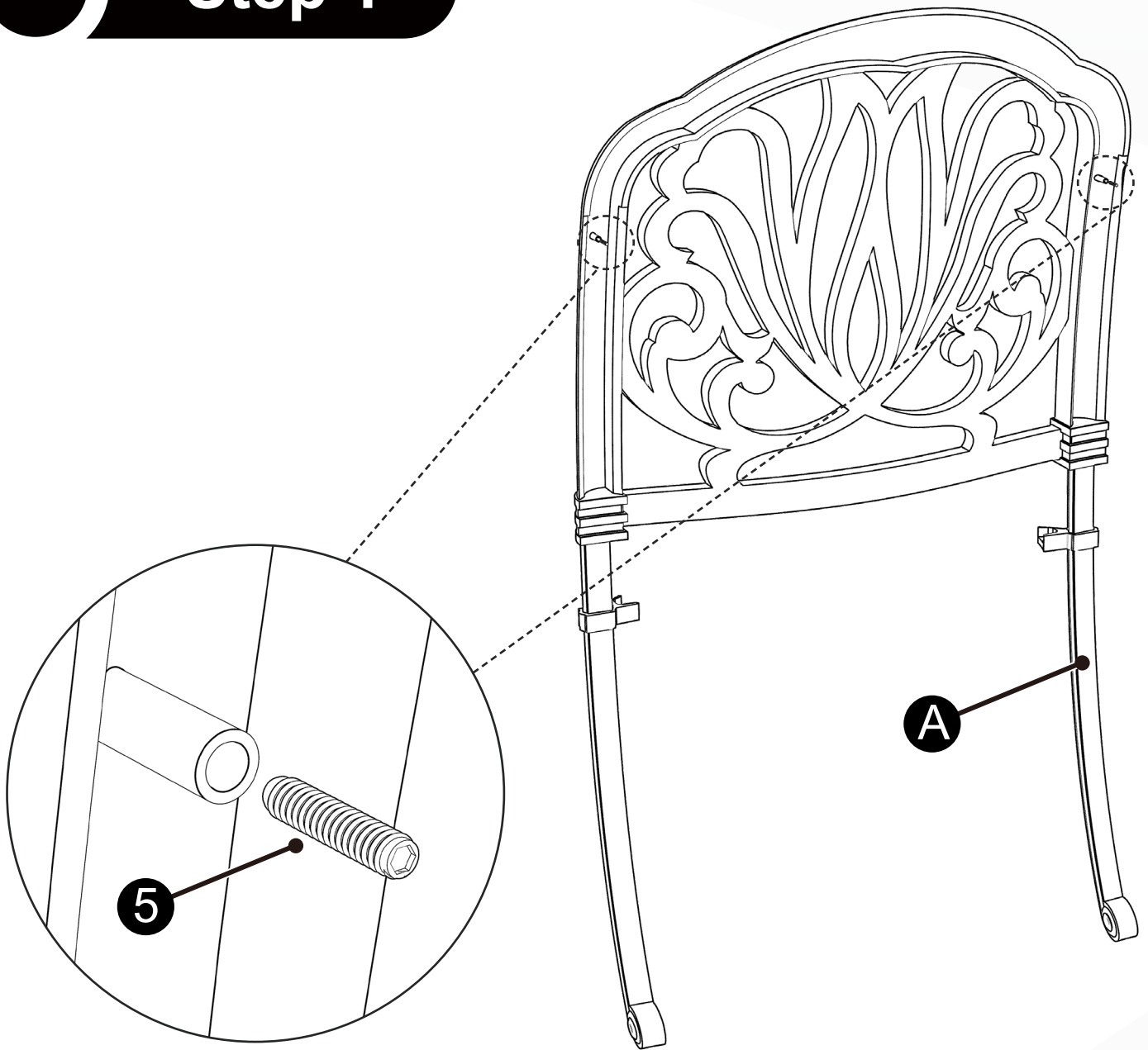

Accessories:

Part 5 \* 2, Part A \* 1

Note: Hexagonal groove should face upwards.

## Step 2

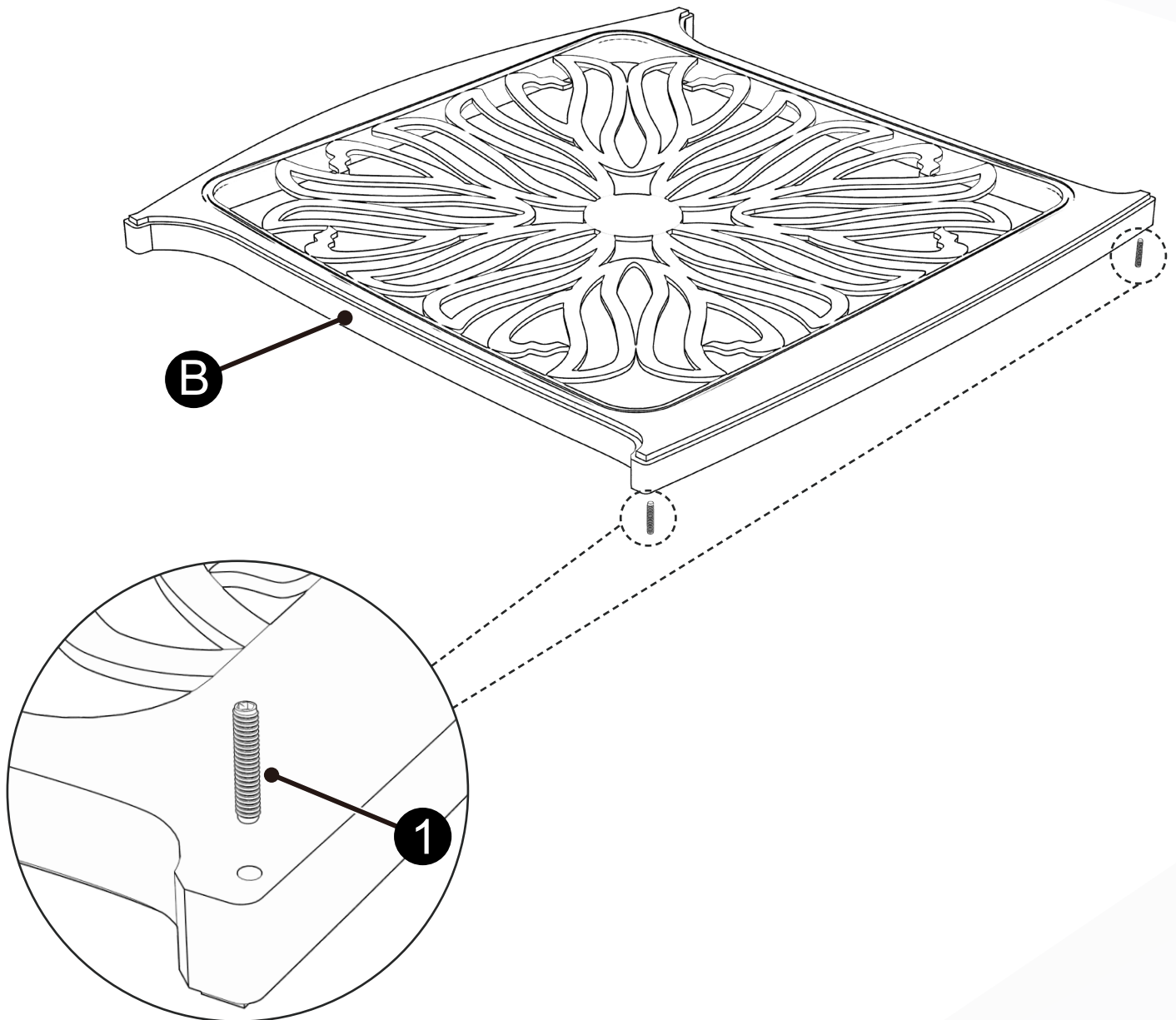

Accessories:

Part 1 \* 2, Part B \* 1

Note: Hexagonal groove should face upwards.

## Step 3



Accessories:

Part 2 \* 2, Part 3 \* 2, Part 4 \* 2, Part B \* 1

Tighten all screws after they were installed.

## Step 4

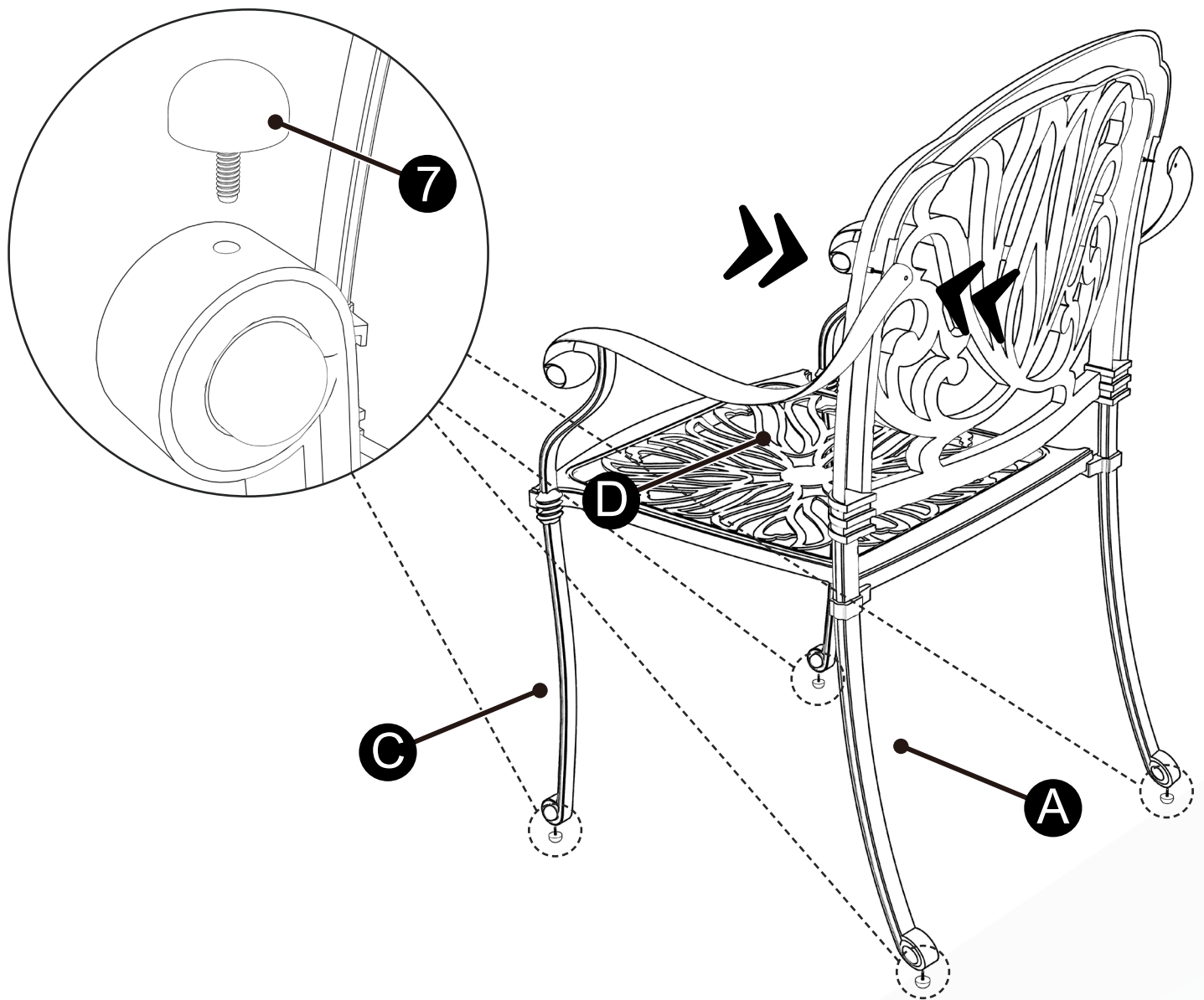

Accessories:

Part 7 \* 4, Part A \* 1, Part C \* 1, Part D \* 1

Note the splice of the parts' grooves.

## Step 5



### Accessories:

Part 2 \* 2, Part 3 \* 2, Part 4 \* 2

Part A \* 1, Part C \* 1, Part D \* 1

Tighten all screws after they were installed.

## Step 6

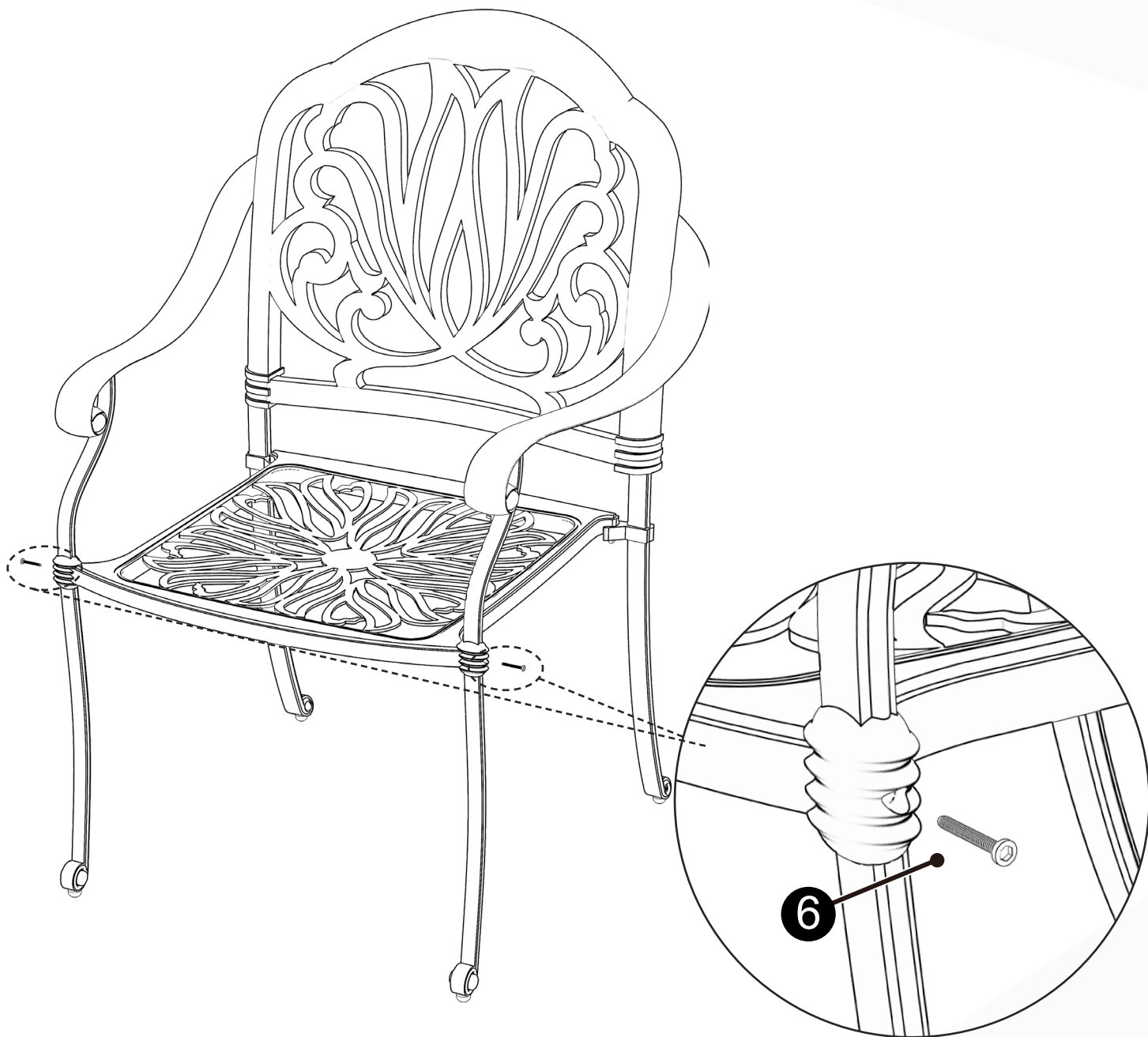

Accessories:

Part 6 \* 2

# Step 7

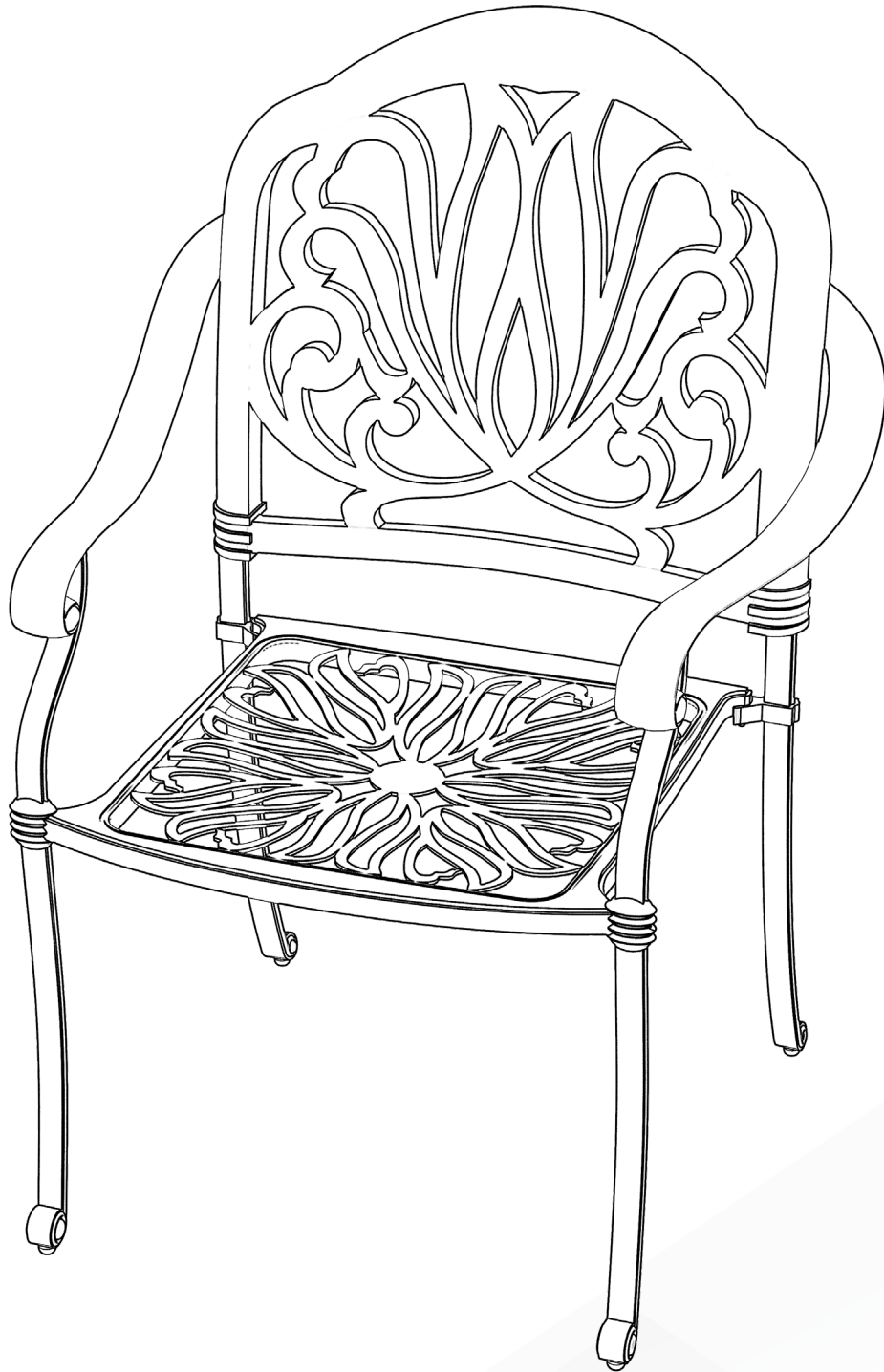

## **WARRANTY**

- The quality of our products has been strictly controlled. Each stage of the product upgrading has condensed the efforts of employees in various departments. We strive to minimize the probability of failure of new products and insist on providing customers with worry less after-sales after-sales service.
- Our products come with a two-month warranty and we are willing to help you solve any problems during the warranty period. Please contact us in time. we will cooperate asap to offer help.
- In order to save your time, please describe the problem in detail. If possible, we hope you can upload product pictures for our reference, and inform us the part number according to the instructions.

## **AFTER-SALE POLICY**

In order to better provide after-sales service experience, we provide the following after-sales policies. At the same time, we also hope that you can actively cooperate with us.

- Within the warranty period of the product, In case of product quality problems, you can contact us, we can provide you with parts replacement services, but for functional issues, we hope you could cooperate with us to complete the troubleshooting steps we told you and inform us the result so we could help you solve it.
- For the return problem, we do not accept unreasonable refunds. If you are not satisfied within 3 days after receiving the goods, we hope you can contact us as soon as possible. After we checked, you must return the product in their original status, so you could qualify for a refund.