

IT'S AS EASY AS 1,2,3

Assembly tips:

1. Read the instructions and become familiar with the parts.
2. Ensure this carton contains all parts, fasteners and hardware.
3. To protect floors, assemble the furniture on the carton.
4. An assistant may be helpful.
5. Use of power tools is not recommended.

Conseils d'assemblage:

1. Lisez les instructions et familiarisez-vous avec les pièces.
2. Assurez-vous que le carton contient toutes les pièces, toutes les pièces de fixation et toute la quincaillerie.
3. Pour protéger vos sols, assemblez le meuble sur le carton.
4. Il peut être utile de vous faire aider.
5. L'utilisation d'outils électriques n'est pas recommandée.

Consejos de Ensamblaje:

1. Lea las instrucciones y familiarícese con las partes.
2. Asegúrese de que esta caja contenga todas las piezas, los sujetadores y el equipo.
3. Para proteger el piso, ensamble el mueble en el carton.
4. Un asistente puede serle útil.
5. El uso de herramientas eléctricas no se recomienda.

IMPORTANT SAFETY INFORMATION



WARNING

Do not load unit without properly attaching back panel. Doing so could cause instability, product collapse, and/or serious injury.

No cargue esta unidad sin el panel de atrás. Hacerlo Puede causar inestabilidad, que el producto se derrumbe, y/o heridas (golpes) serias.

Ne pas charger le produit sans attacher correctement le panneau arrière. Faire ainsi peut causer l'instabilité ou l'effondrement du produit et peut vous causer des endommagements sérieux.



WARNING

Do not move unit when loaded. Doing so could cause instability, product collapse, tip over, and/or serious injury.

No mueva la unidad cuando esté cargada. Hacerlo puede causar inestabilidad, que el producto se derrumbe, que se la caiga encima y/o heridas (golpes) serias.

Ne pas déplacer l'unité lorsqu'elle est chargée. Faire ainsi peut causer l'instabilité, l'effondrement ou le renversement du meuble et/ou des endommagements sérieux.



CAUTION



Risk of breaking glass. Handle glass carefully during assembly. Use eye and hand protection. Improper handling can result in cuts or lacerations.

Riesgo de romper el vidrio. Maneje el vidrio con cuidado al ensamblar esta unidad. Use protección para sus ojos y sus manos. El manejo inapropiado del vidrio puede causarle cortaduras o laceraciones.

Risque de bris de verre. Faites attention lors de la manipulation du verre pendant l'assemblage. Utilisez des protections pour les yeux et les mains. Une mauvaise manipulation peut provoquer des coupures ou des lacérations.

EXPLODED VIEW

- A [1]
- B [1]
- C [1]
- D [1]
- E [1]
- F [1]
- G [3]
- H [1]
- I [1]
- J [1]
- K [1]

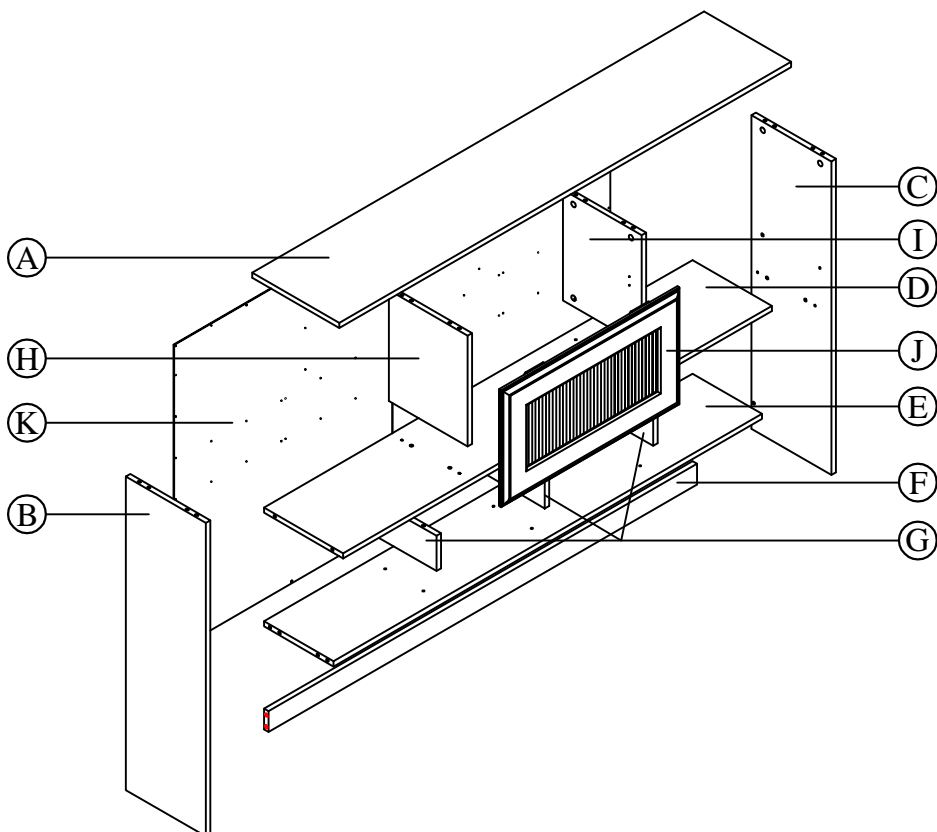
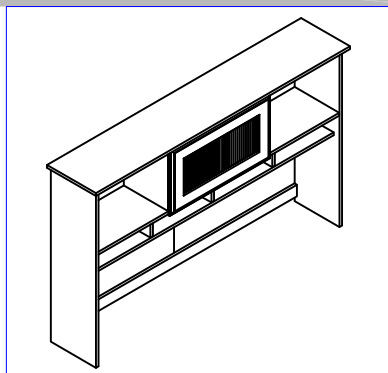

FASTENERS

Fasteners are shown in actual size.

Los fijadores son demostrados en su tamaño actual.

Les attaches sont montrées dans l'échelle grandeur.

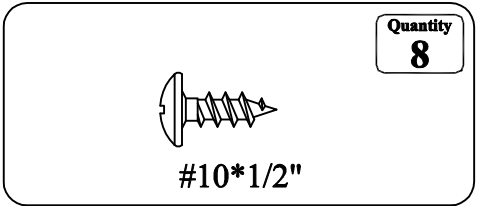
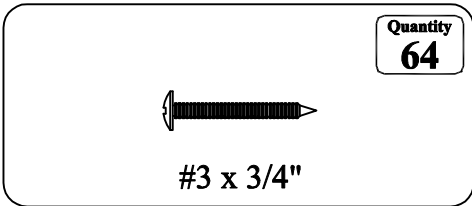
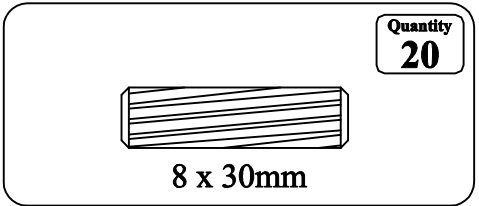
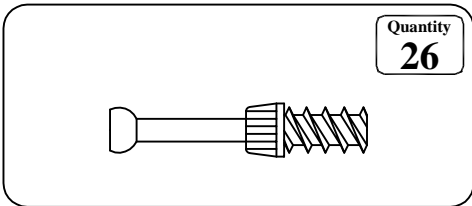
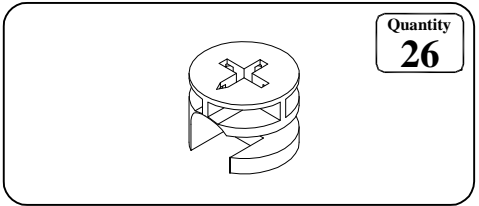
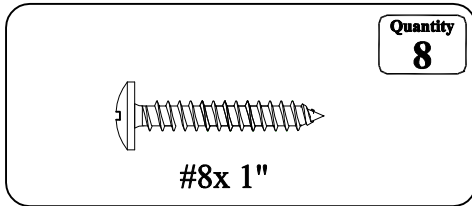
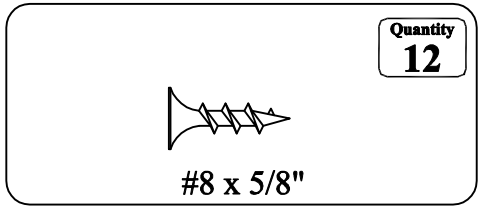
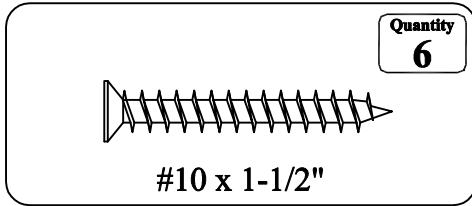

HARDWARE

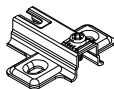

Quantity
2

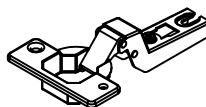

Quantity
2

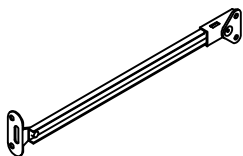

Quantity
1

F

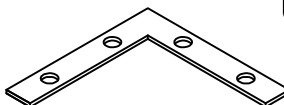

Quantity
2



Quantity
24



Quantity
2

Common assembly techniques.
Técnica común de ensamblaje.
Techniques communes d'assemblage.

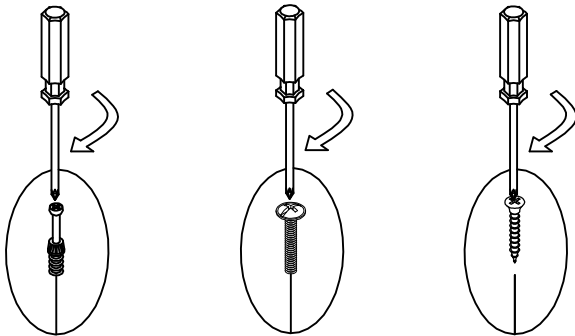
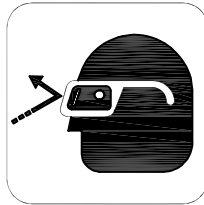
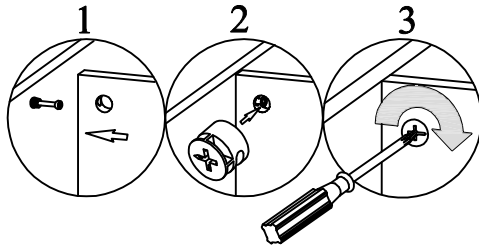

STEP 1

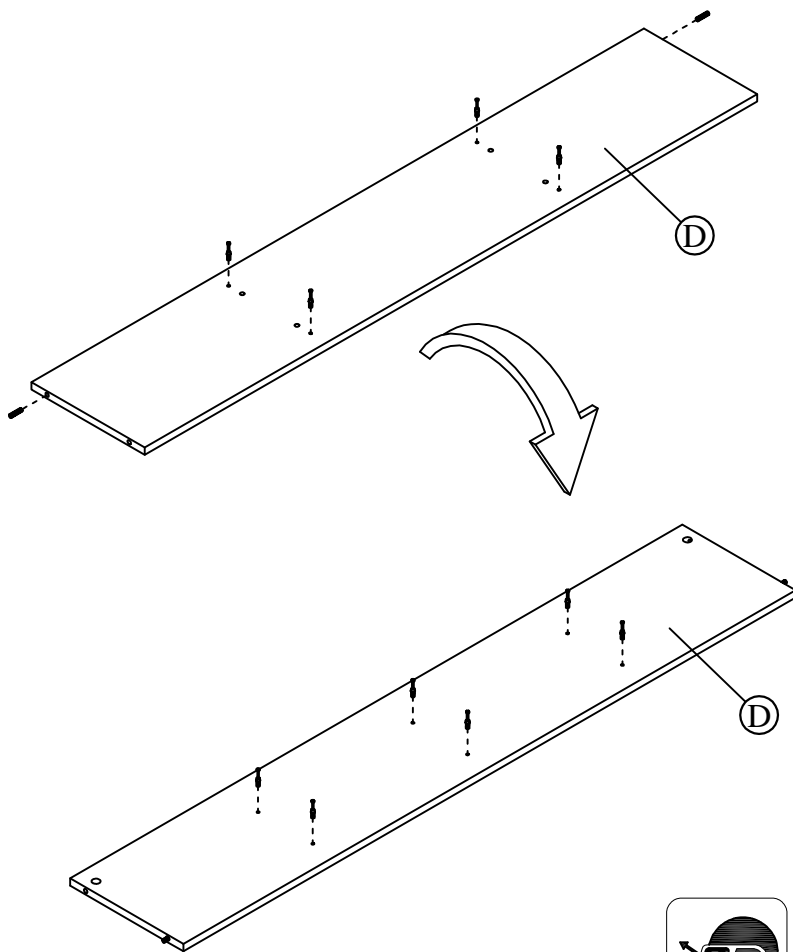

STEP 2

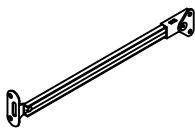

[1]



[8]

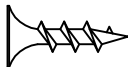

[2]

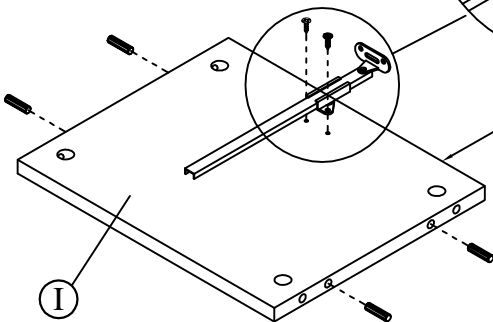
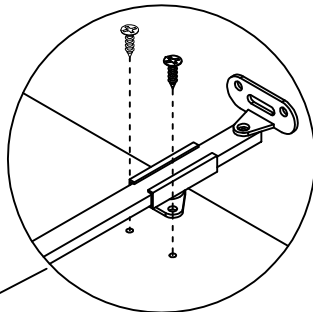

Finished edge
Borde terminado
Cote fini

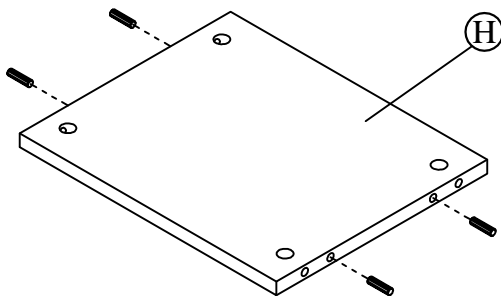

STEP 3



[10]

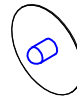

[10]

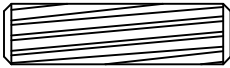

[4]

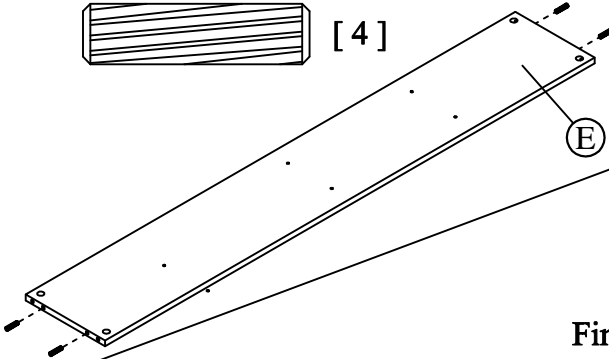

(E)

Finished edge
Borde terminado
Cote fini

Finished edge
Borde terminado
Cote fini

(I)

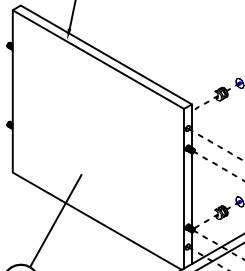

(H)

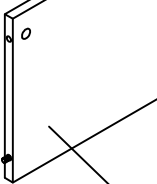

(D)



(G)

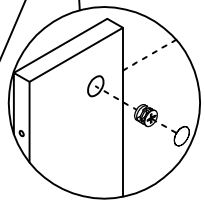

STEP 4

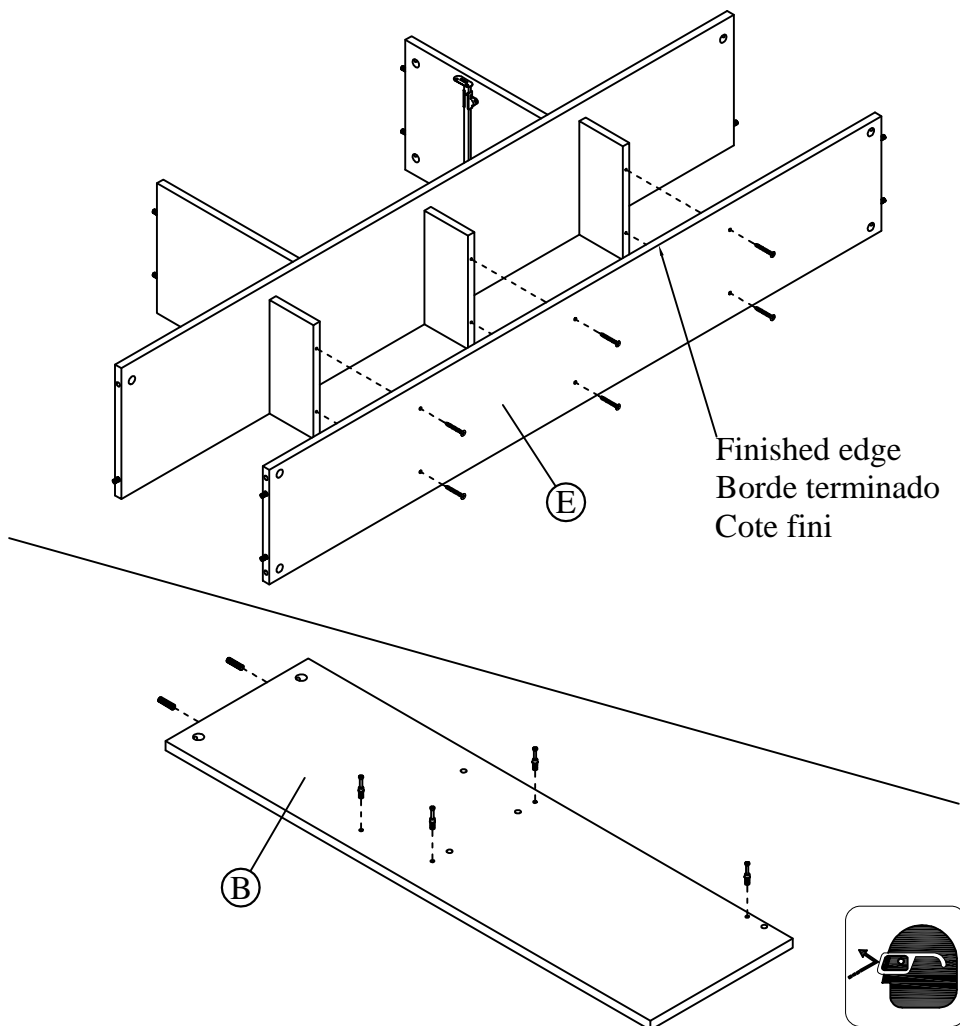
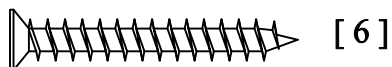

STEP 5

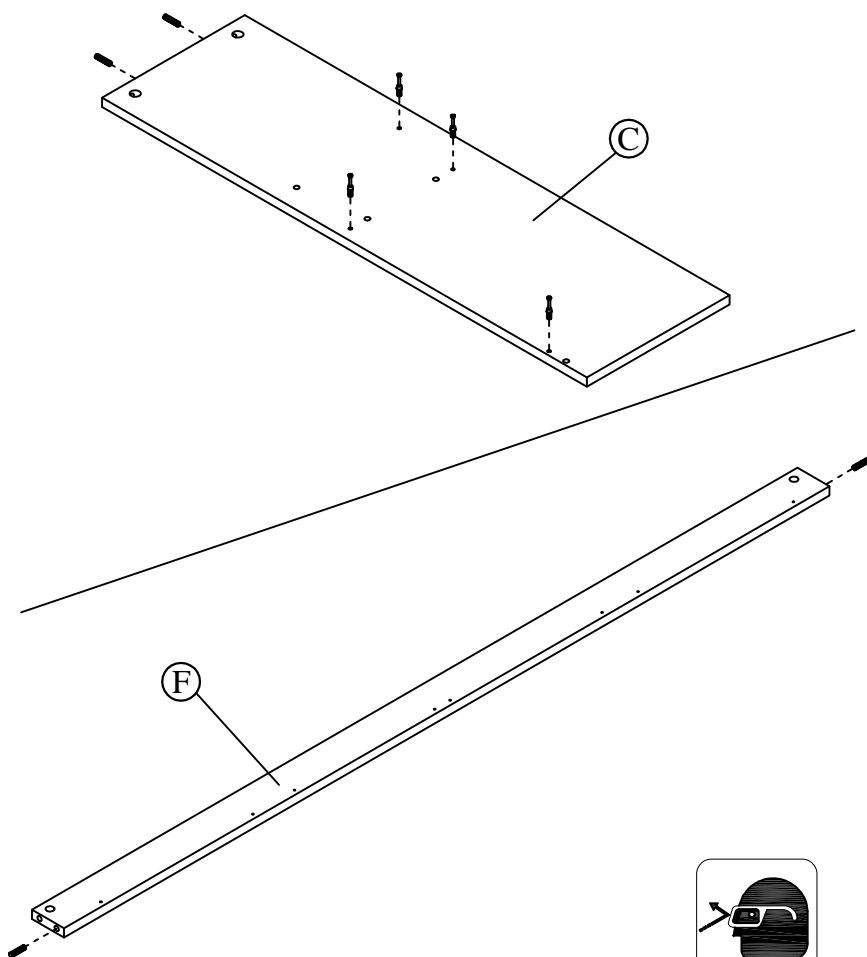

STEP 6



[6]

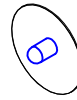

[6]

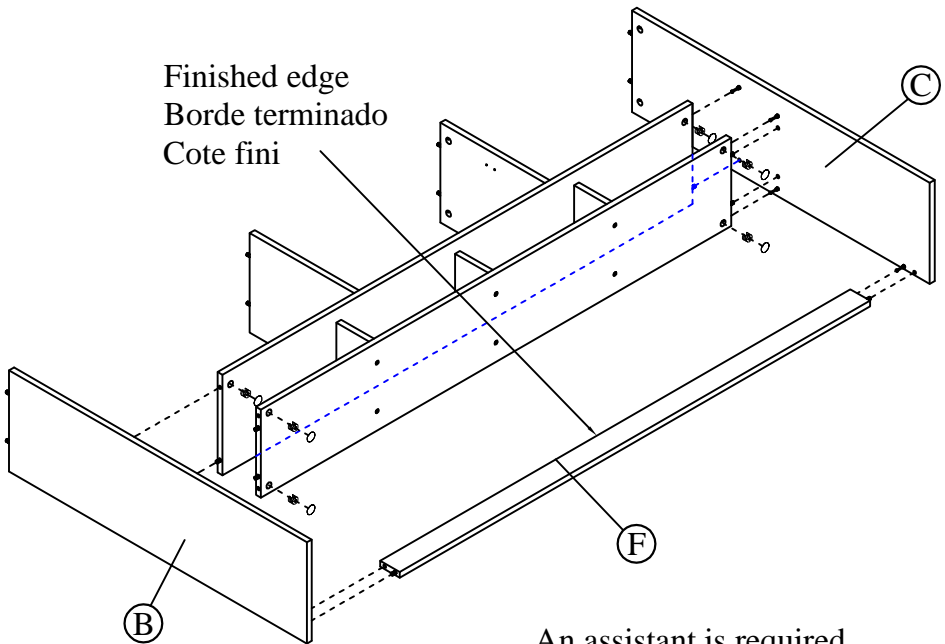

An assistant is required.
Es necesario un ayudante.
Un assistant est nécessaire.

STEP 7

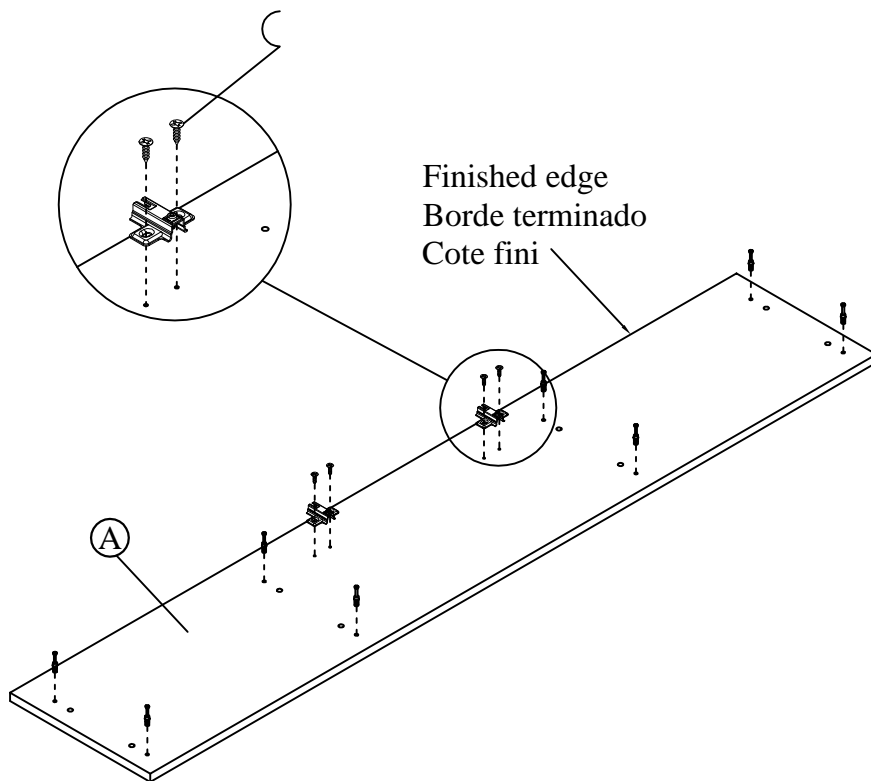
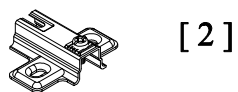

STEP 8

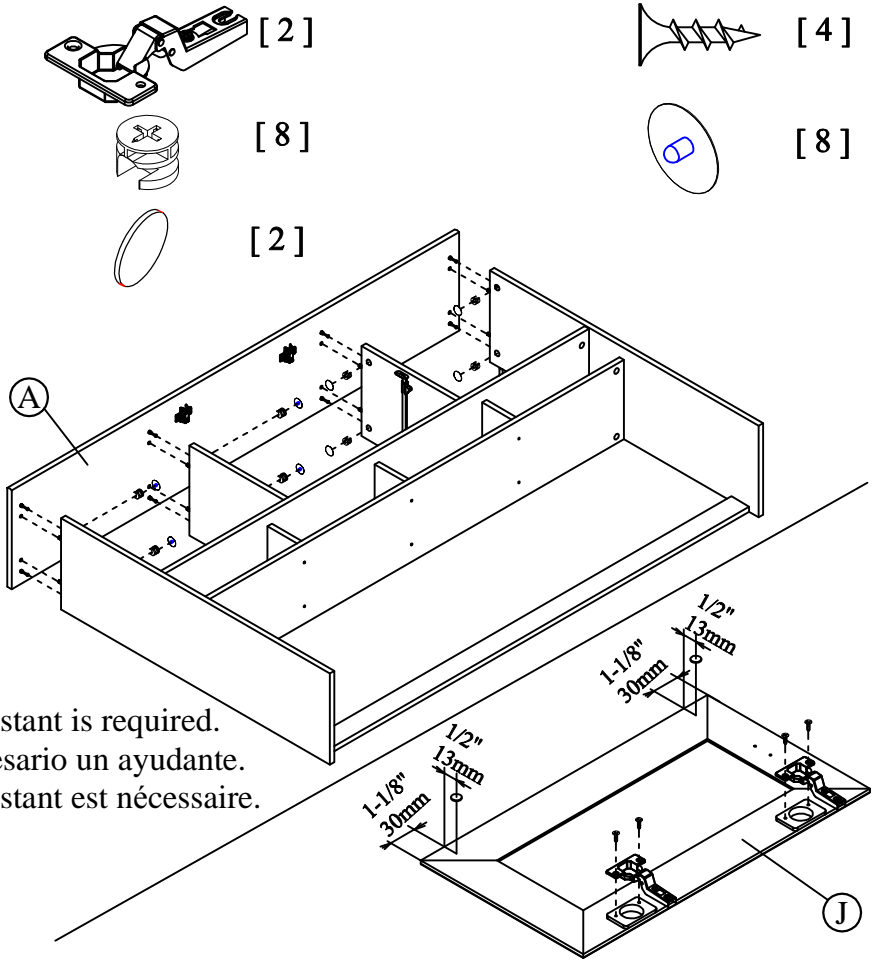

An assistant is required.
 Es necesario un ayudante.
 Un assistant est nécessaire.



CAUTION



Risk of breaking glass. Handle glass carefully during assembly. Use eye and hand protection. Improper handling can result in cuts or lacerations.

Riesgo de romper el vidrio. Maneje el vidrio con cuidado al ensamblar esta unidad. Use protección para sus ojos y sus manos. El manejo inapropiado del vidrio puede causarle cortaduras o laceraciones.

Risque de bris de verre. Faites attention lors de la manipulation du verre pendant l'assemblage. Utilisez des protections pour les yeux et les mains. Une mauvaise manipulation peut provoquer des coupures ou des lacérations.

STEP 9



[2]

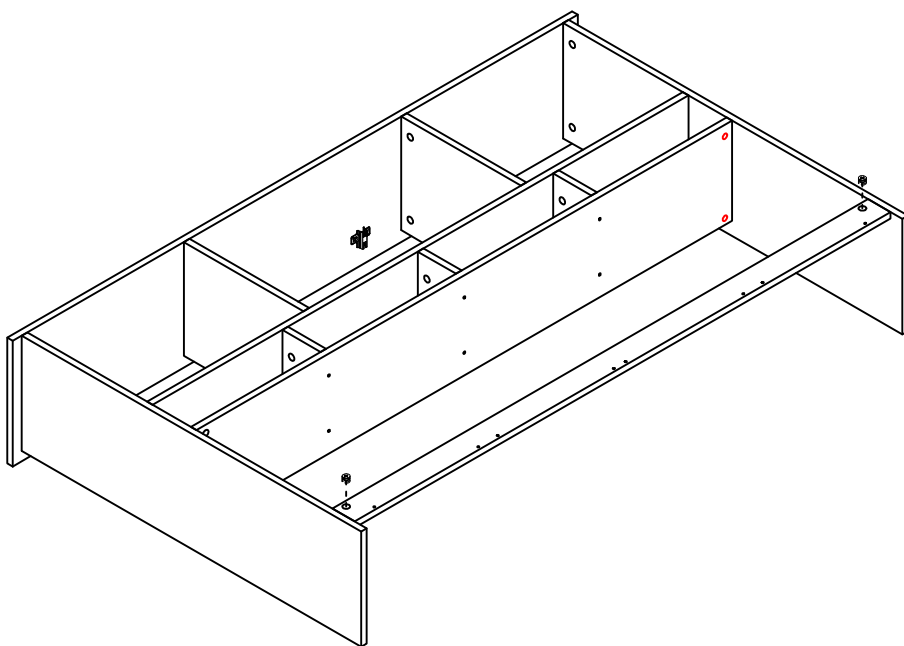

STEP 10



An assistant is required.
Es necesario un ayudante.
Un assistant est nécessaire.

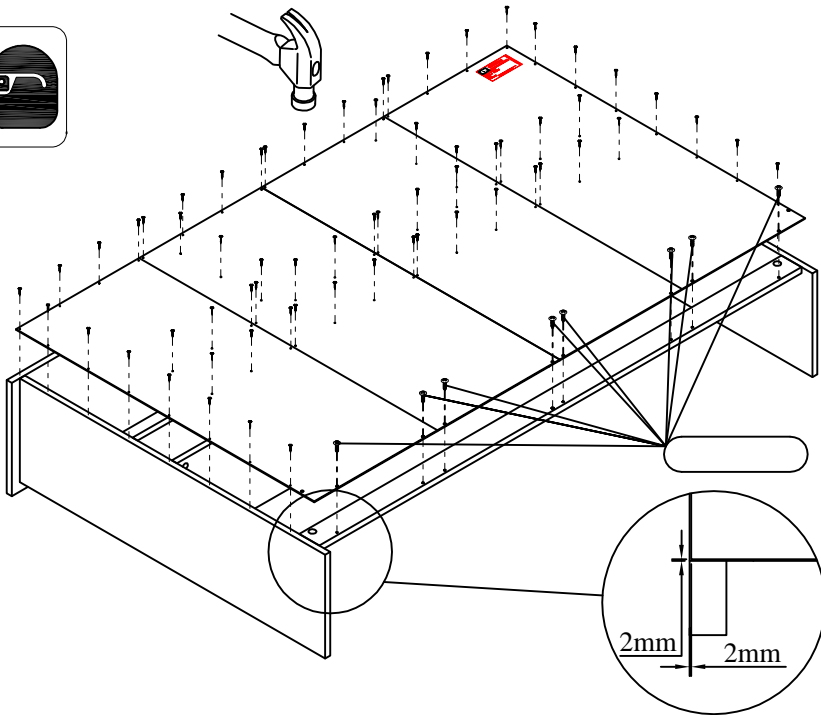

WARNING

Do not load unit without properly attaching back panel. Doing so could cause instability, product collapse, and/or serious injury.

No cargue esta unidad sin el panel de atrás. Hacerlo Puede causar inestabilidad, que el producto se derrumbe, y/o heridas (golpes) serias.

Ne pas charger le produit sans attacher correctement le panneau arrière. Faire ainsi peut causer l'instabilité ou l'effondrement du produit et peut vous causer des endommagements sérieux.

STEP 11

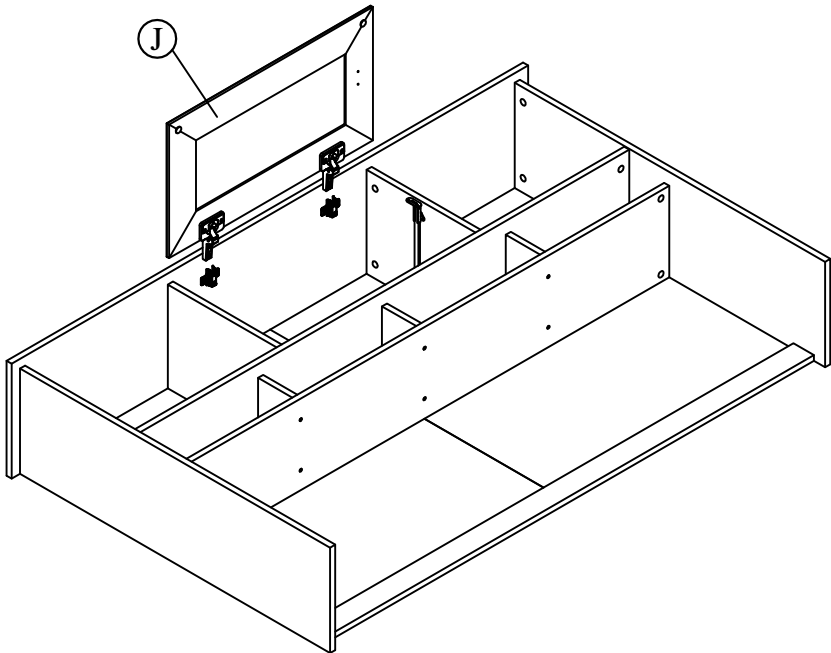
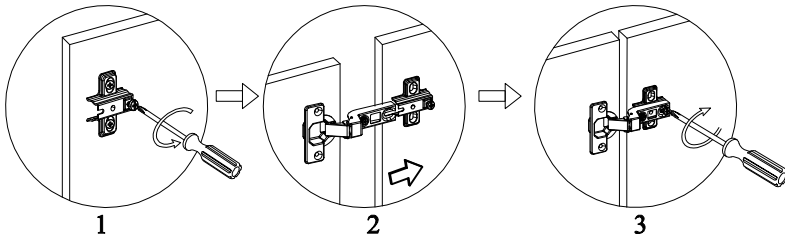

CAUTION



Risk of breaking glass. Handle glass carefully during assembly. Use eye and hand protection. Improper handling can result in cuts or lacerations.

Riesgo de romper el vidrio. Maneje el vidrio con cuidado al ensamblar esta unidad. Use protección para sus ojos y sus manos. El manejo inapropiado del vidrio puede causarle cortaduras o laceraciones.

Risque de bris de verre. Faites attention lors de la manipulation du verre pendant l'assemblage. Utilisez des protections pour les yeux et les mains. Une mauvaise manipulation peut provoquer des coupures ou des lacérations.

STEP 12

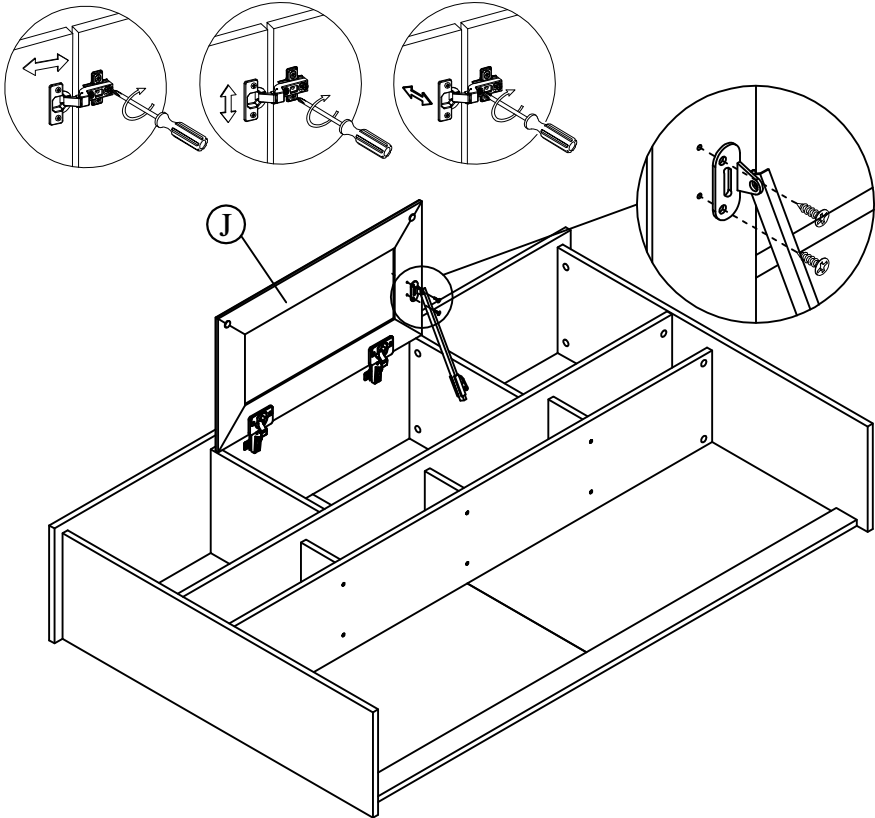

CAUTION



Risk of breaking glass. Handle glass carefully during assembly. Use eye and hand protection. Improper handling can result in cuts or lacerations.

Riesgo de romper el vidrio. Maneje el vidrio con cuidado al ensamblar esta unidad. Use protección para sus ojos y sus manos. El manejo inapropiado del vidrio puede causarle cortaduras o laceraciones.

Risque de bris de verre. Faites attention lors de la manipulation du verre pendant l'assemblage. Utilisez des protections pour les yeux et les mains. Une mauvaise manipulation peut provoquer des coupures ou des lacérations.

STEP 13

The following assembly and attachment steps apply to either the left or right mounting options.
El procedimiento descrito aplica a ambas opciones de ensamblaje: izquierda y derecha.
Les étapes suivantes pour l'assemblage et la fixation s'appliquent aux options de montage sur la gauche ou sur la droite.

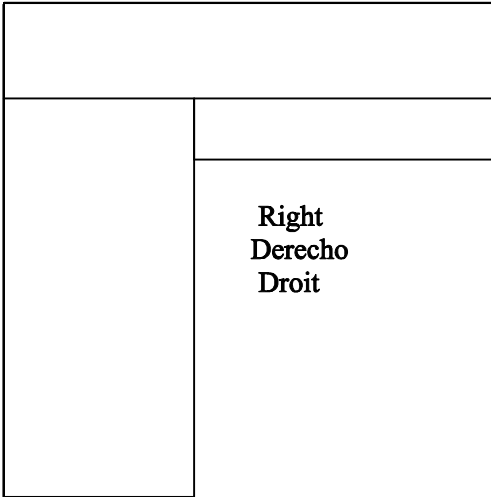

Right
Derecho
Droit

Go to step 14.
Proceda al paso 14.
Allez à l'étape 14.

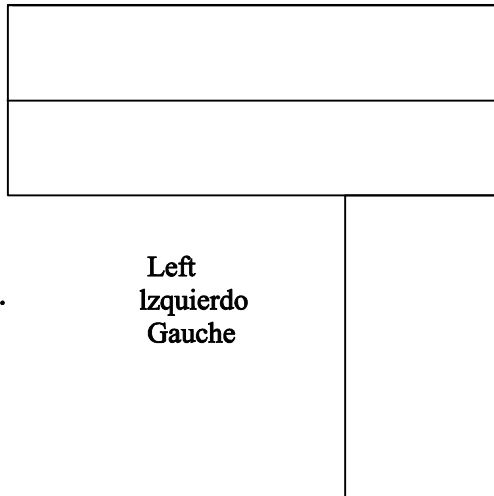

Go to step 15.
Proceda al paso 15.
Allez à l'étape 15.

Left
Izquierdo
Gauche

STEP 14

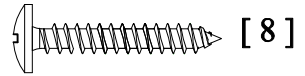
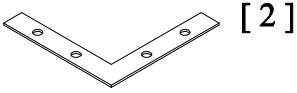

An assistant is required.
Es necesario un ayudante.
Un assistant est nécessaire.

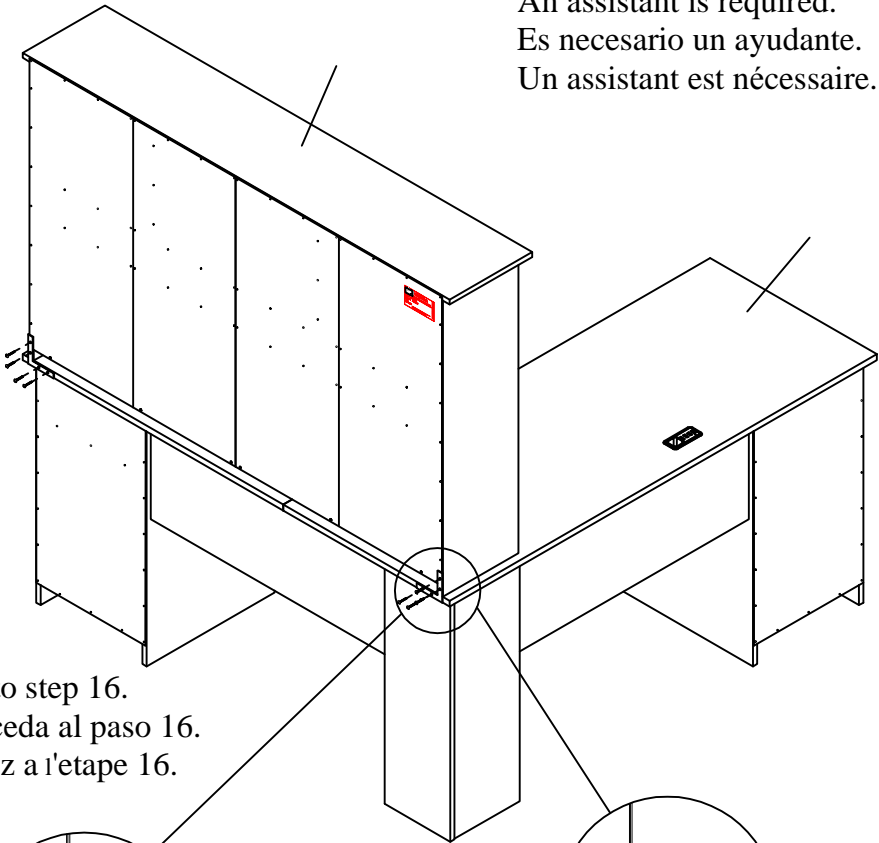

Go to step 16.
Proceda al paso 16.
Allez a l'etape 16.

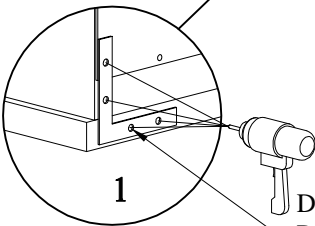

Drill (8) 1/8" holes 3/4" deep.
Perfore (8) agujeros de 3mm a 19mm de profundo.
Percer (8) trous de 3mm de diamètre et 19mm de profondeur.

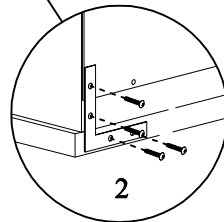

STEP 15

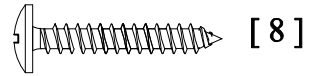
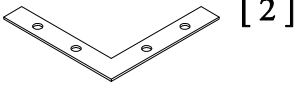

An assistant is required.
Es necesario un ayudante.
Un assistant est nécessaire.

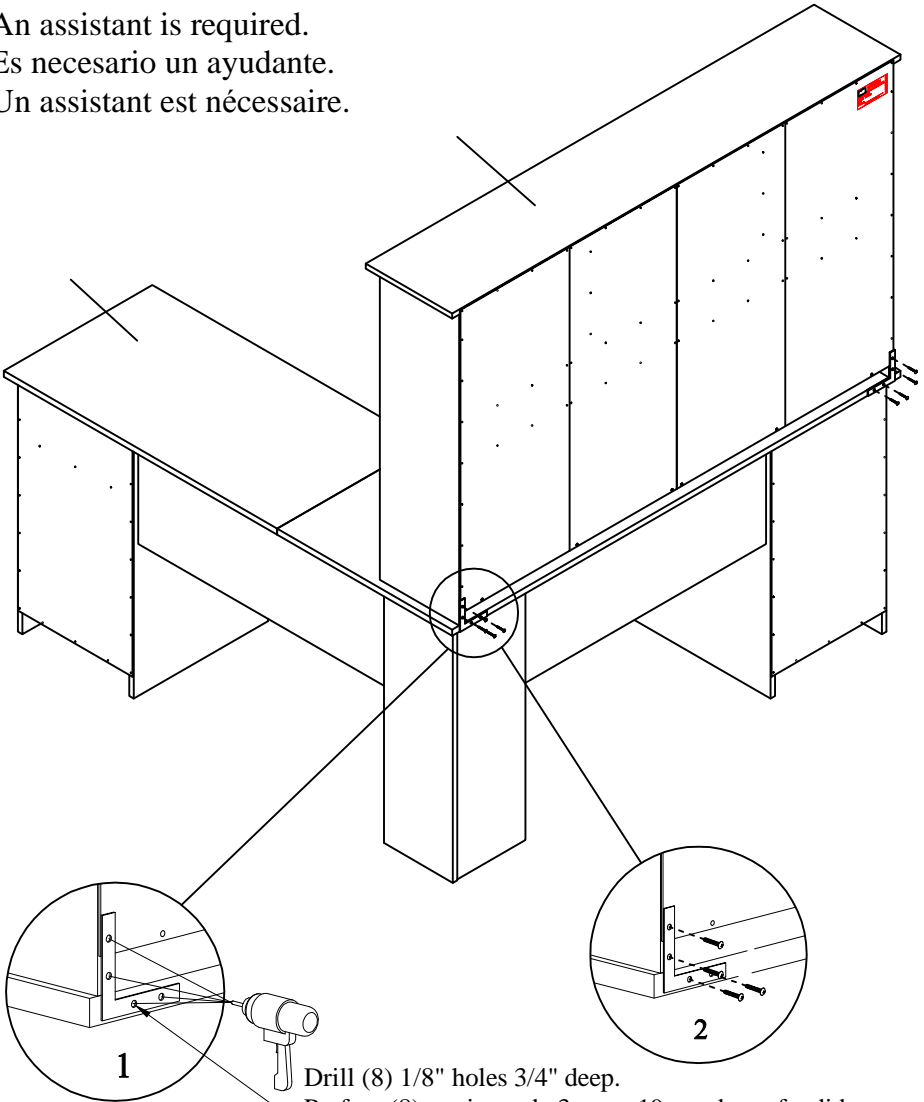

Drill (8) 1/8" holes 3/4" deep.
Perfore (8) agujeros de 3mm a 19mm de profundidad.
Percer (8) trous de 3mm de diamètre et 19mm de profondeur.

STEP 16

**Maximum Weight: 0 Lbs.
Peso Máximo: 0 Libras
Poids Maximum: 0 kilogramme**

**Maximum Weight: 25 Lbs.
Peso Máximo: 25 Libras
Poids Maximum: 11.3 kilogramme**

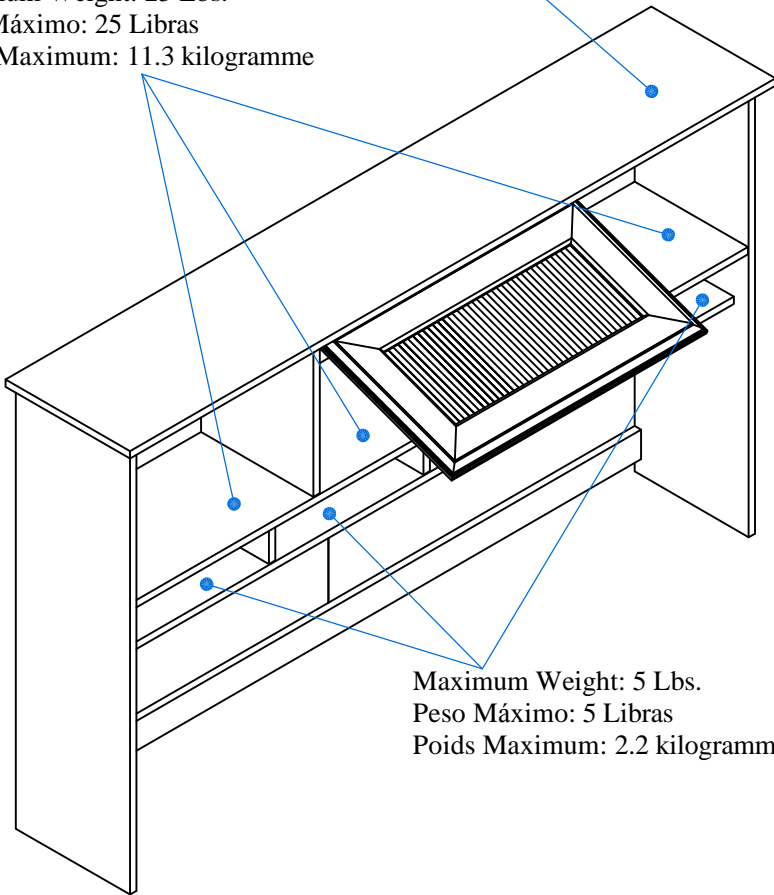

**Maximum Weight: 5 Lbs.
Peso Máximo: 5 Libras
Poids Maximum: 2.2 kilogramme**