

# Installation & Assembly

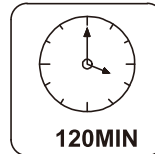

**EN\_IMPORTANT, RETAIN FOR FUTURE REFERENCE: READ CAREFULLY.**

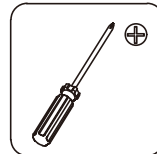
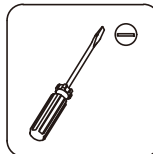
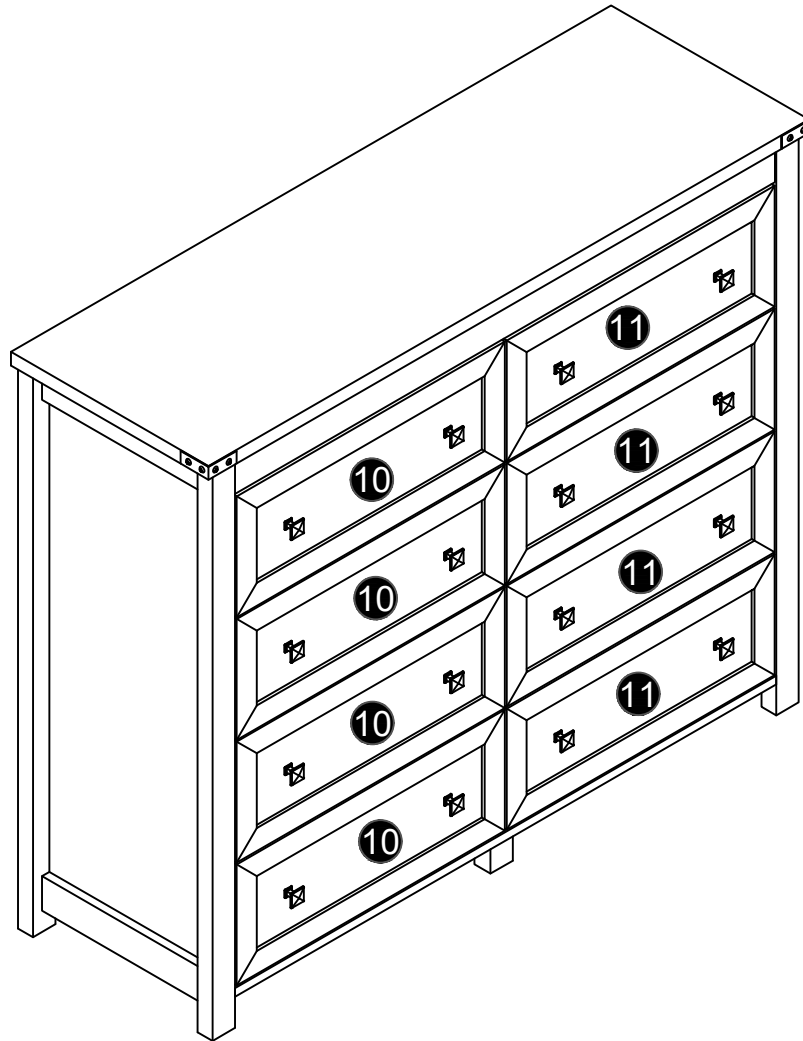
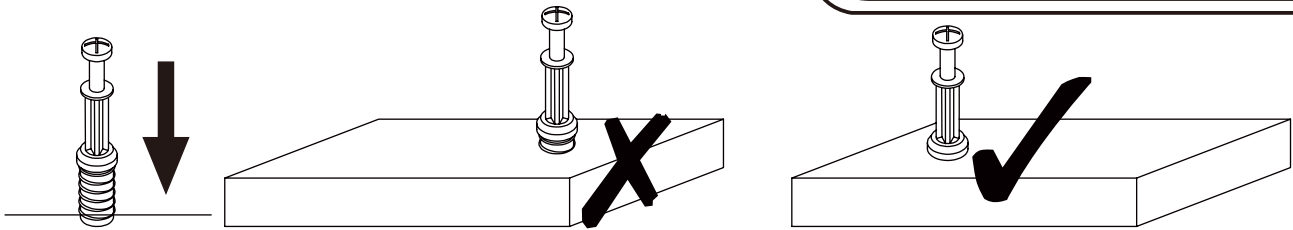

**EN\_QUICKFIT:** Tighten quickfit until shoulder is flush with panel. Do not overtighten or undertighten.

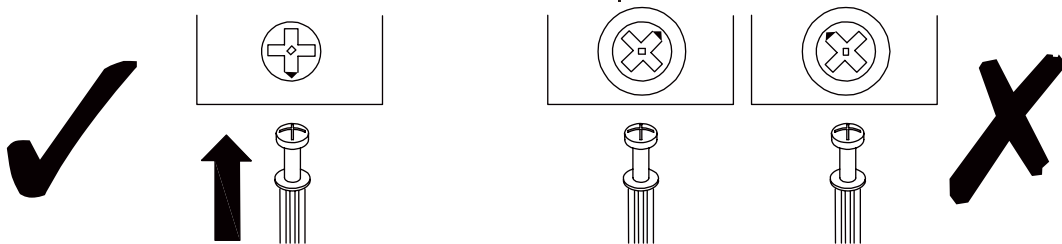

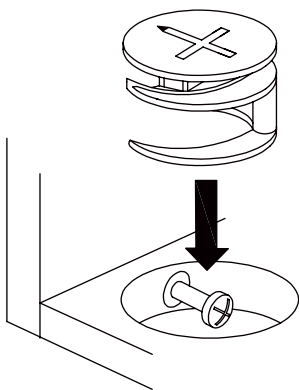

**EN\_CAM LOCK:** When fitting cam lock, ensure starting position is correct before you insert connecting quickfit.

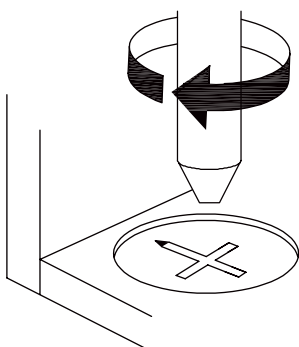

**EN\_Quickfit** head should be in the centre of the cam lock when the two panels are joined.  
Cam lock should be inserted before quickfit.



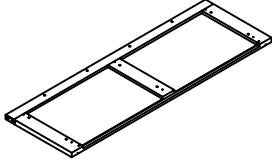
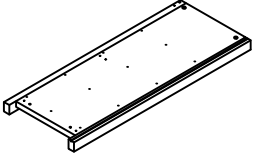
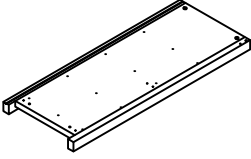
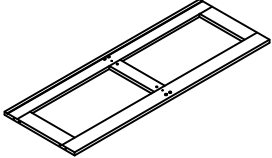

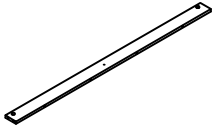
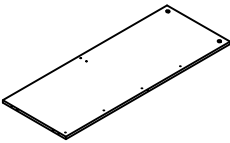
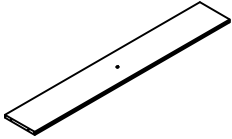
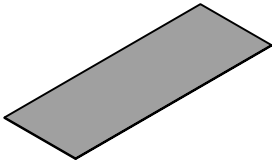
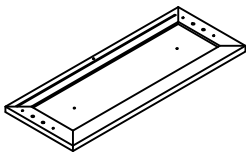

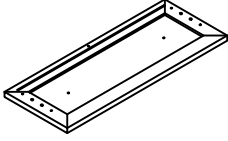
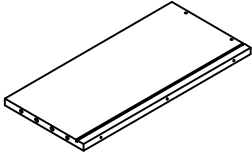
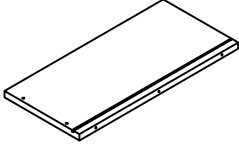
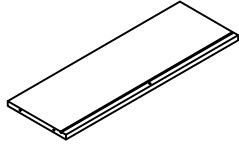
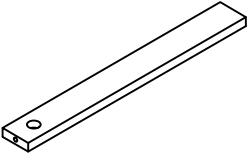
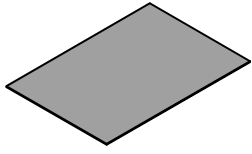
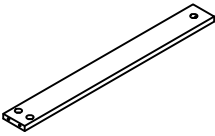
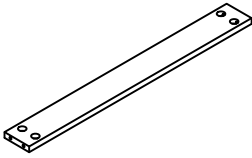
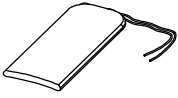

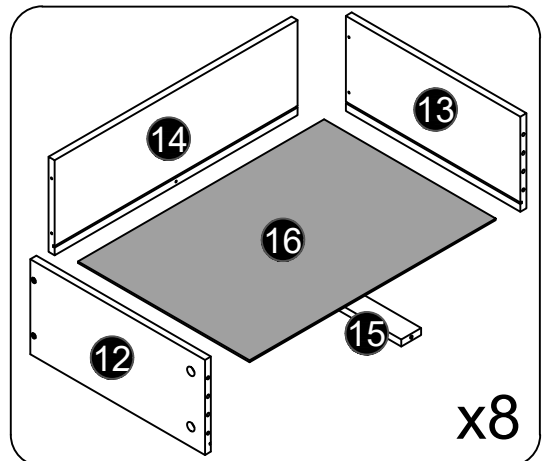
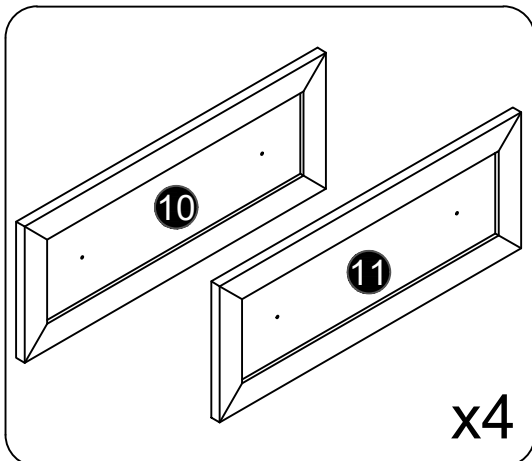
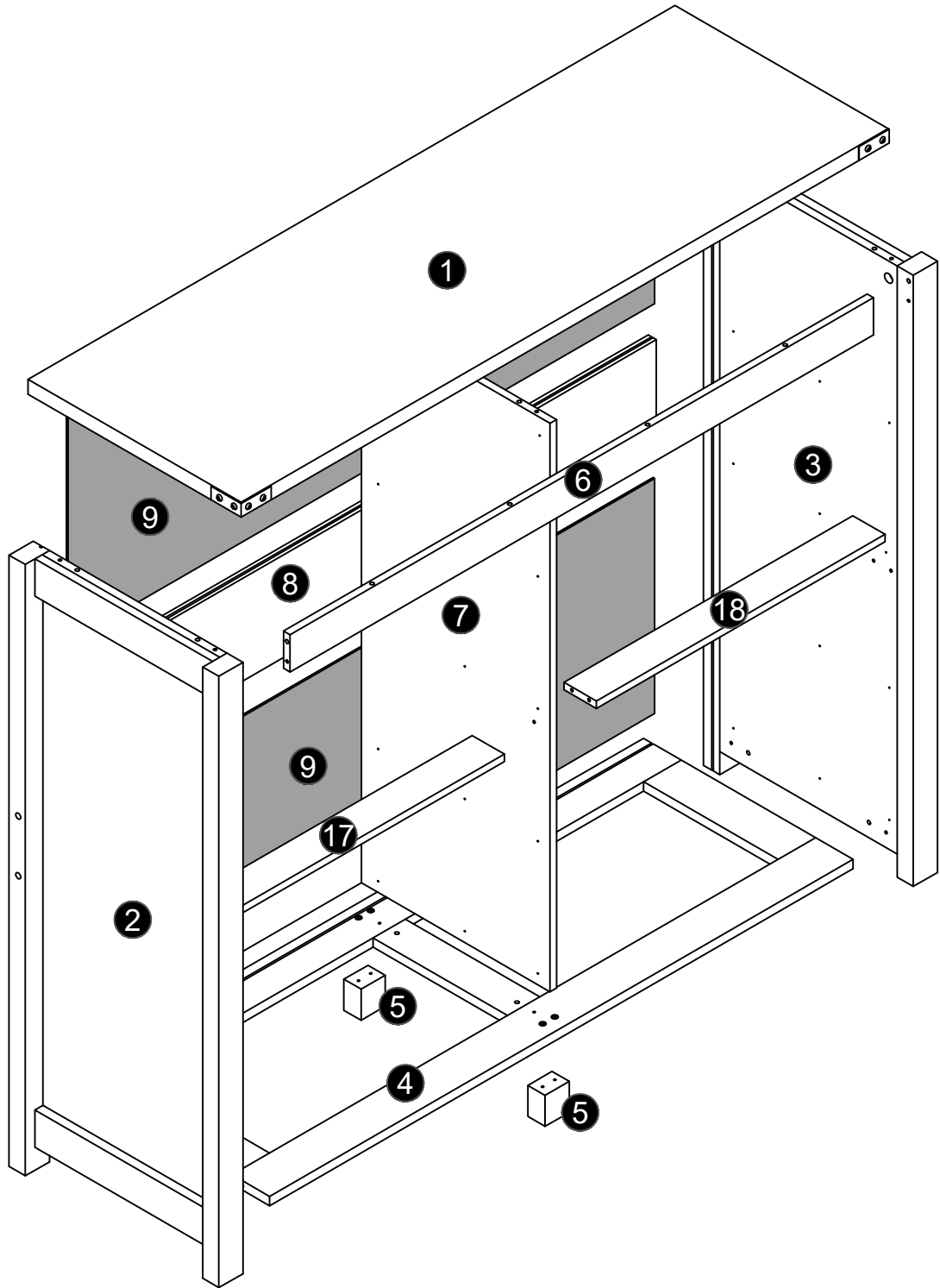

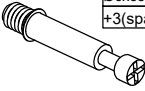

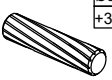
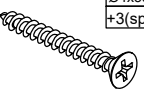



**EN\_Turn** cam lock clockwise to tighten.

NO.	PARTS	QTY	SPARE
①		x1	
②		x1	
③		x1	
④		x1	
⑤		x2	
⑥		x1	
⑦		x1	
⑧		x1	
⑨		x2	
⑩		x4	

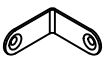
NO.		QTY	SPARE
⑪		x4	
⑫		x8	
⑬		x8	
⑭		x8	
⑮		x8	
⑯		x8	
⑰		x1	
⑱		x1	
	 Hardware Kit	x1	

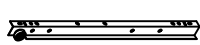

<p><b>A</b> x59 Ø6x35mm +3(spare)</p> 	<p><b>B</b> x59 Ø15x10mm +3(spare)</p> 	<p><b>C</b> x50 Ø6x30mm +3(spare)</p> 	<p><b>D</b> x47 Ø4x35mm +3(spare)</p> 	<p><b>E</b> x98 Ø3.5x12mm +4(spare)</p> 	<p><b>F</b> x4</p> 
<p><b>G</b> x4</p> 	<p><b>H</b> x16 H-1 H-2</p> 	<p><b>I</b> x2 I-1 I-2</p> 	<p><b>J</b> x12 +1(spare) J-1 J-2</p> 	<p><b>K</b> x2 K-1 K-2</p> 	<p><b>L</b> x4</p> 
<p><b>M</b> x1</p> 	<p><b>N</b> x2</p> 				
<p><b>CL</b> x8 L350mm</p> 	<p><b>CR</b> x8 L350mm</p> 	<p><b>DL</b> x8 L350mm</p> 	<p><b>DR</b> x8 L350mm</p> 		

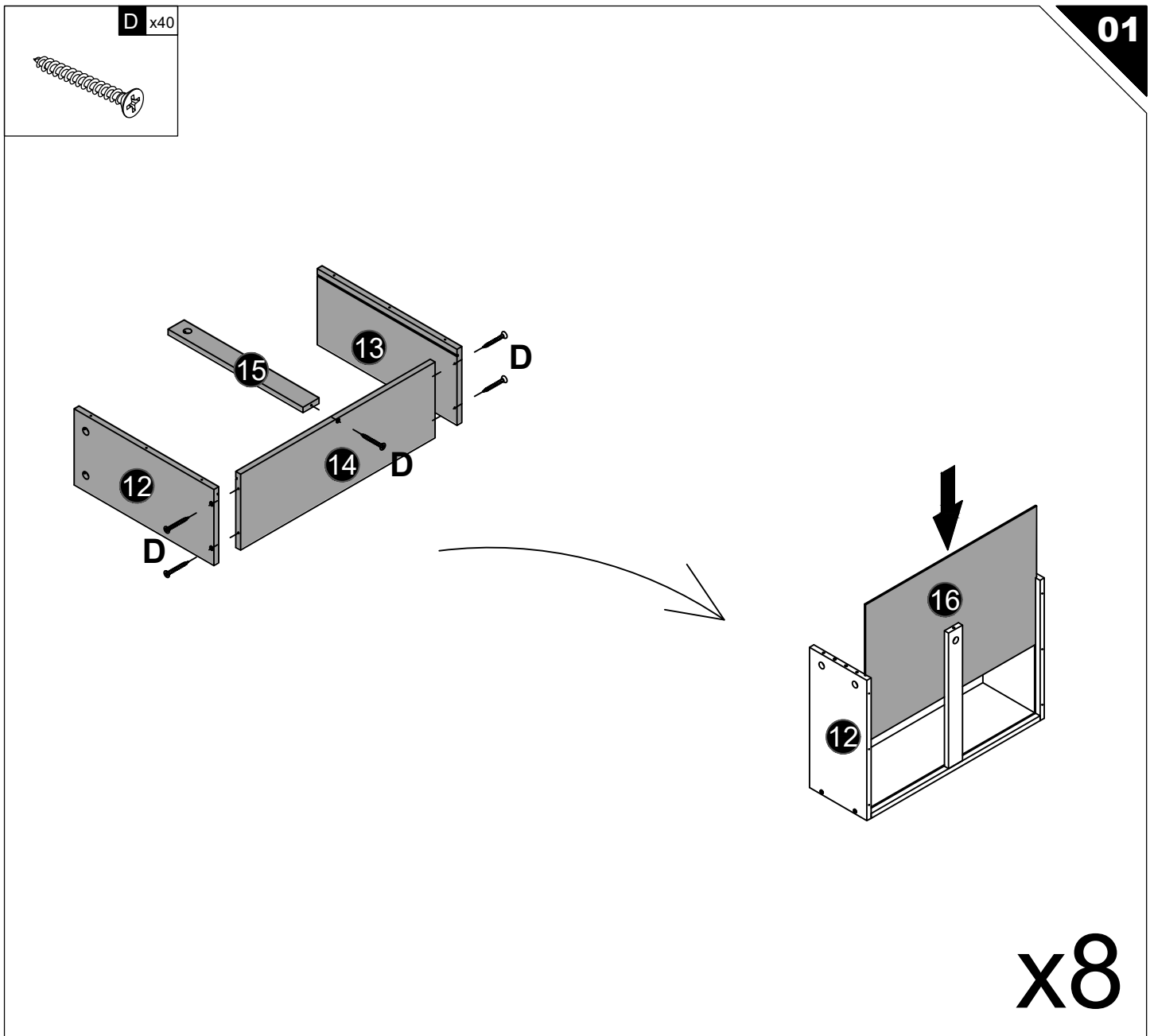

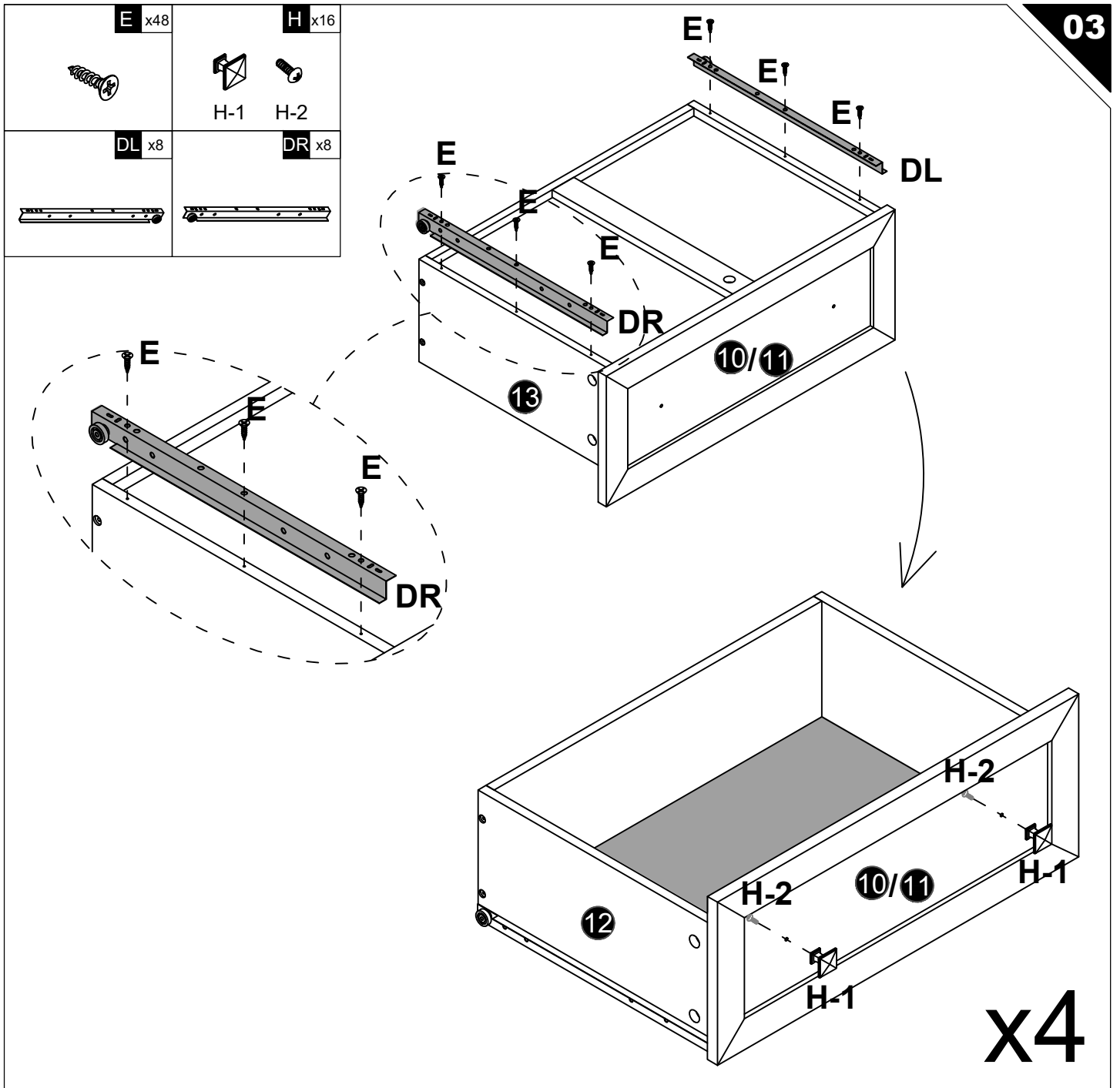
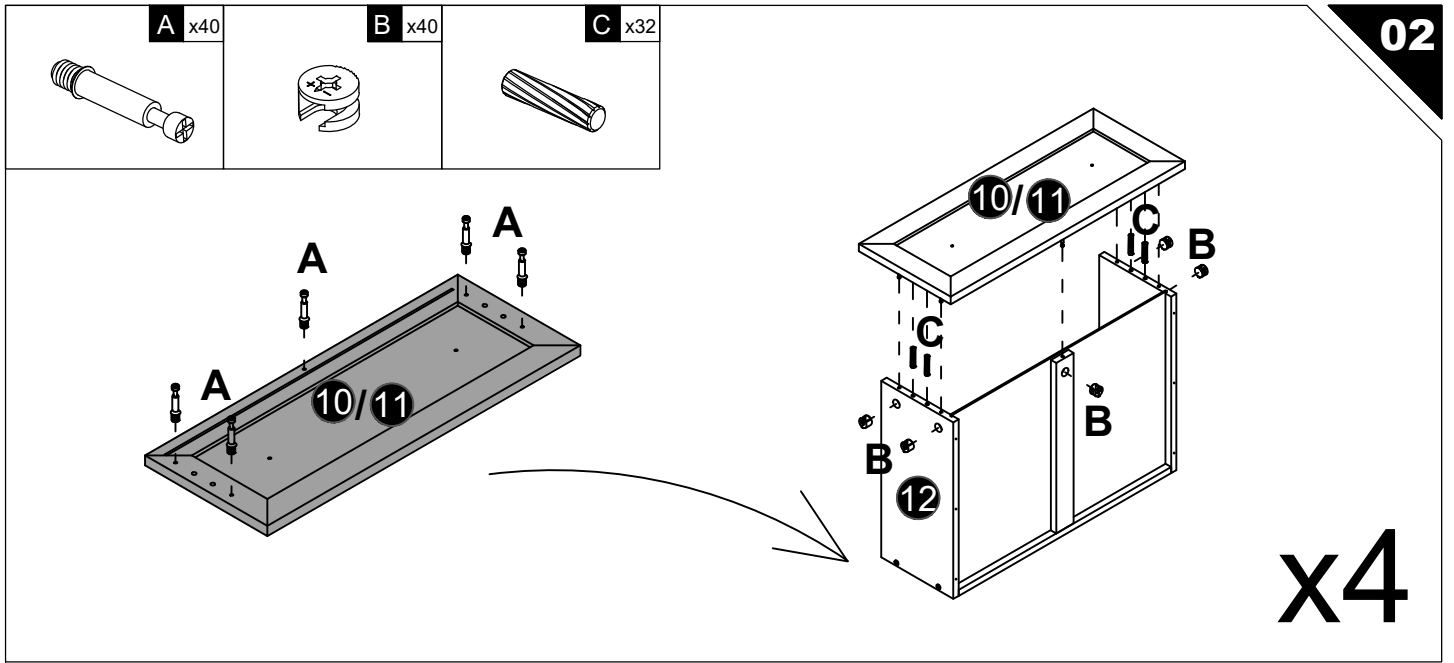

A x3

E x48

CL x8

CR x8

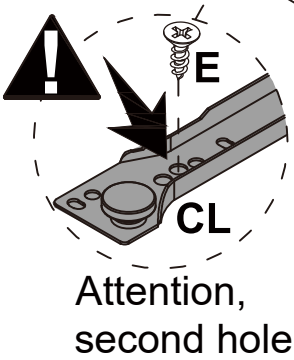
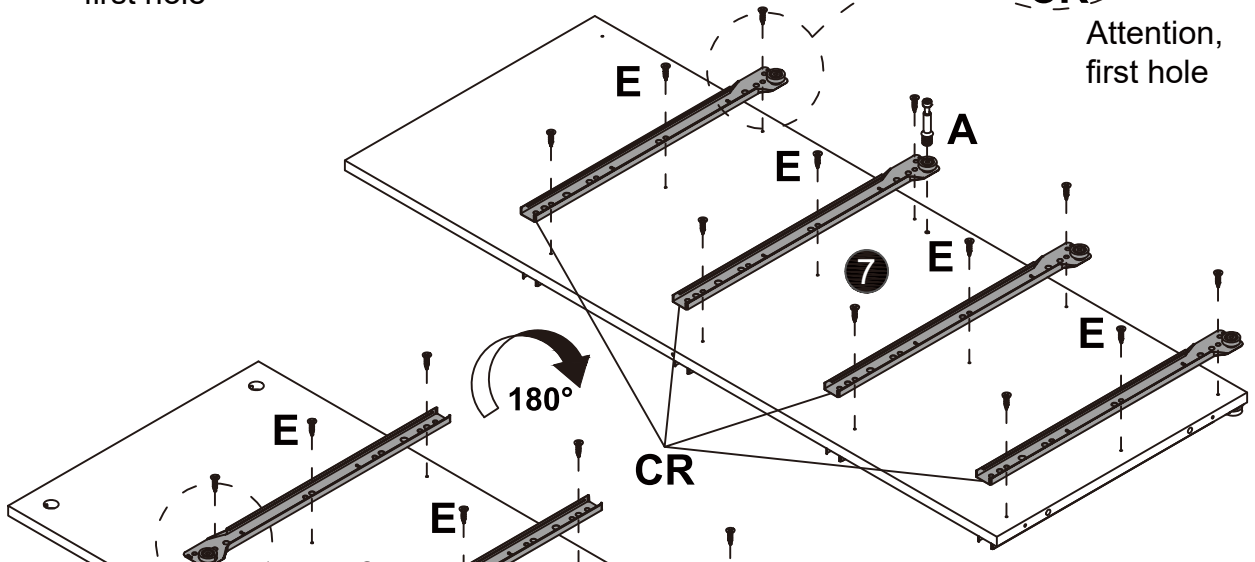
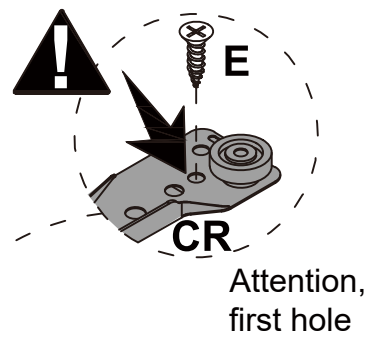
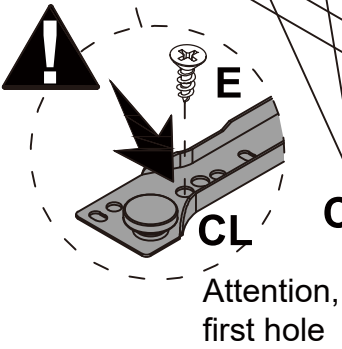
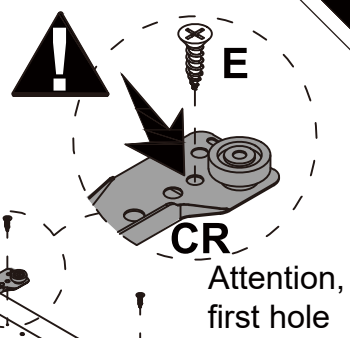
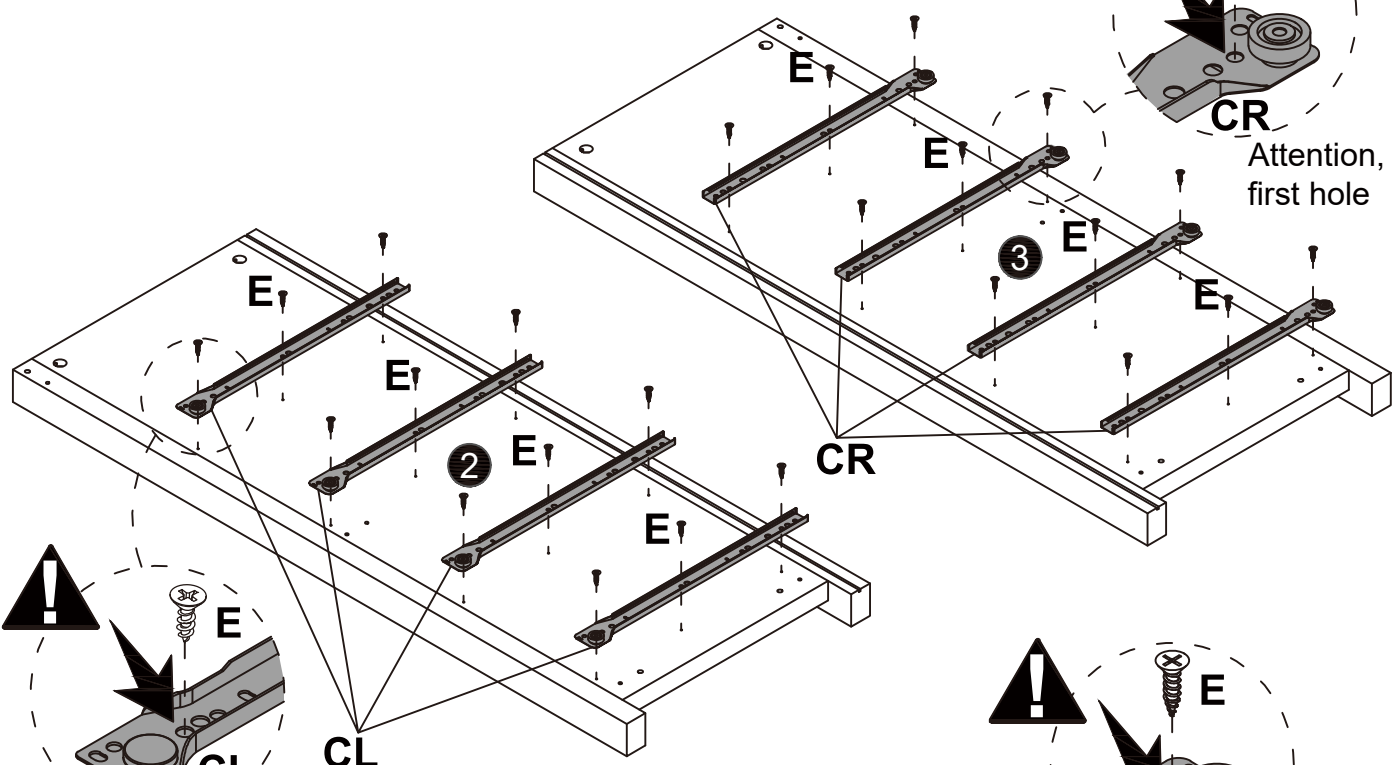
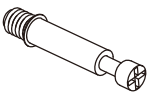



C x2

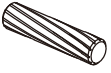

D x2

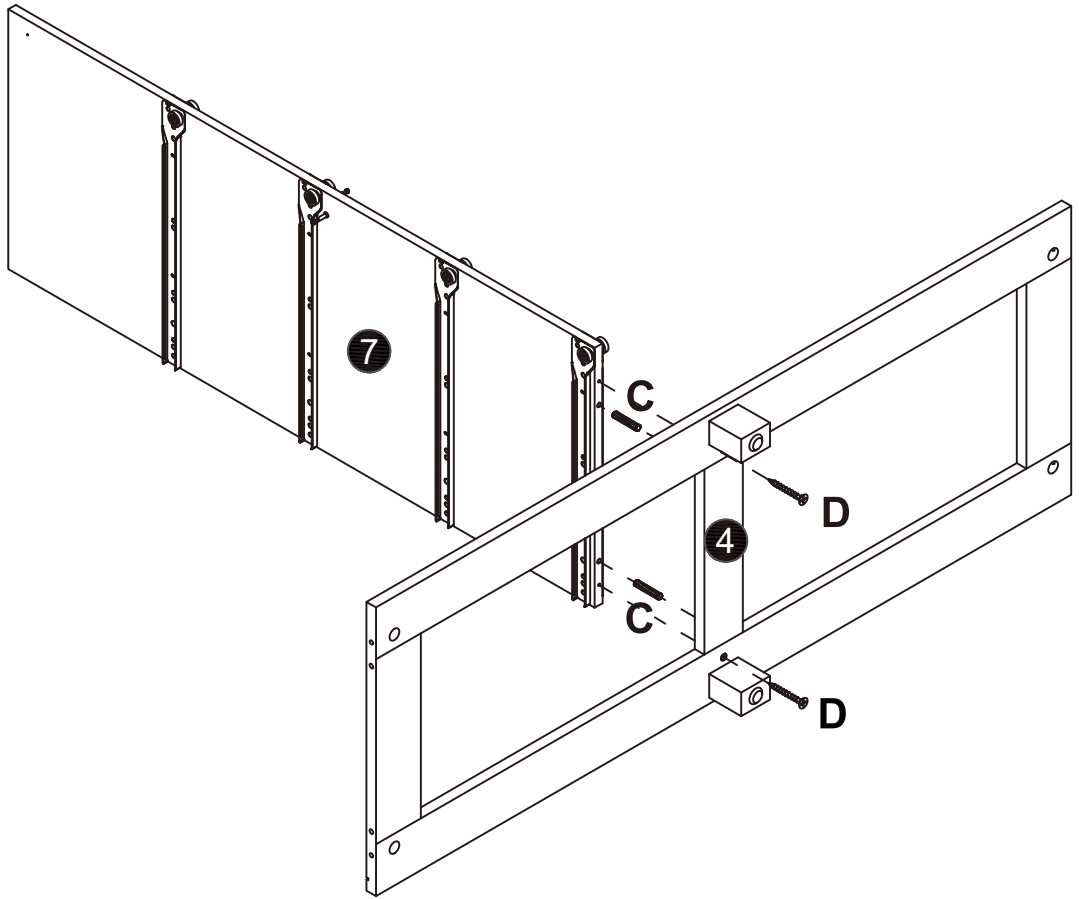
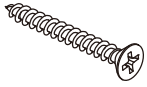

B x3

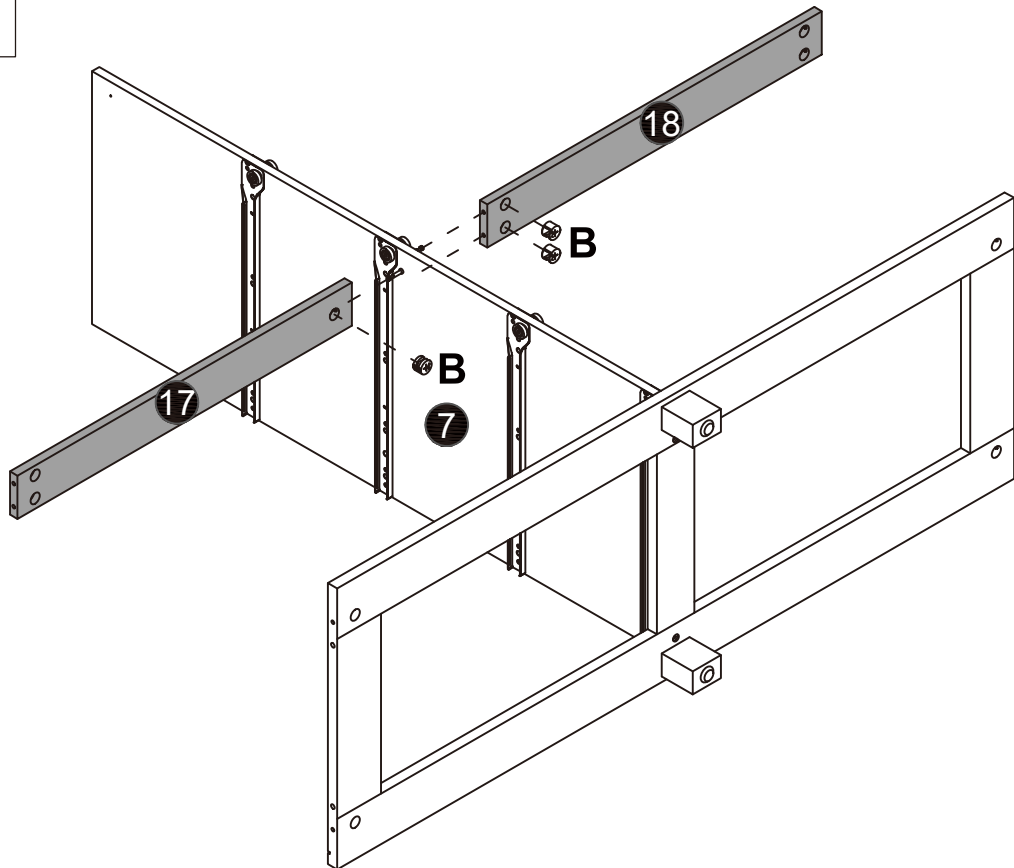

C x3

B x5

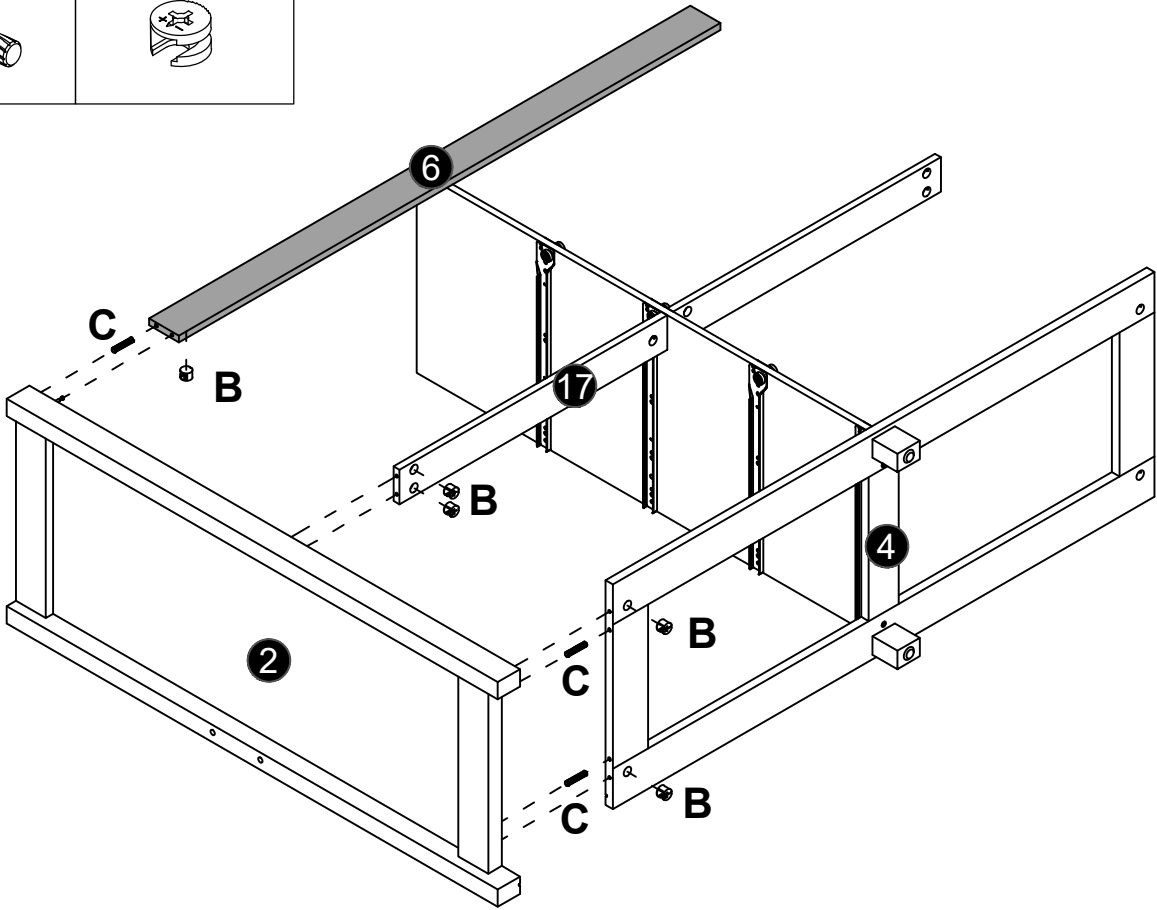
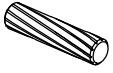

C x3

B x5

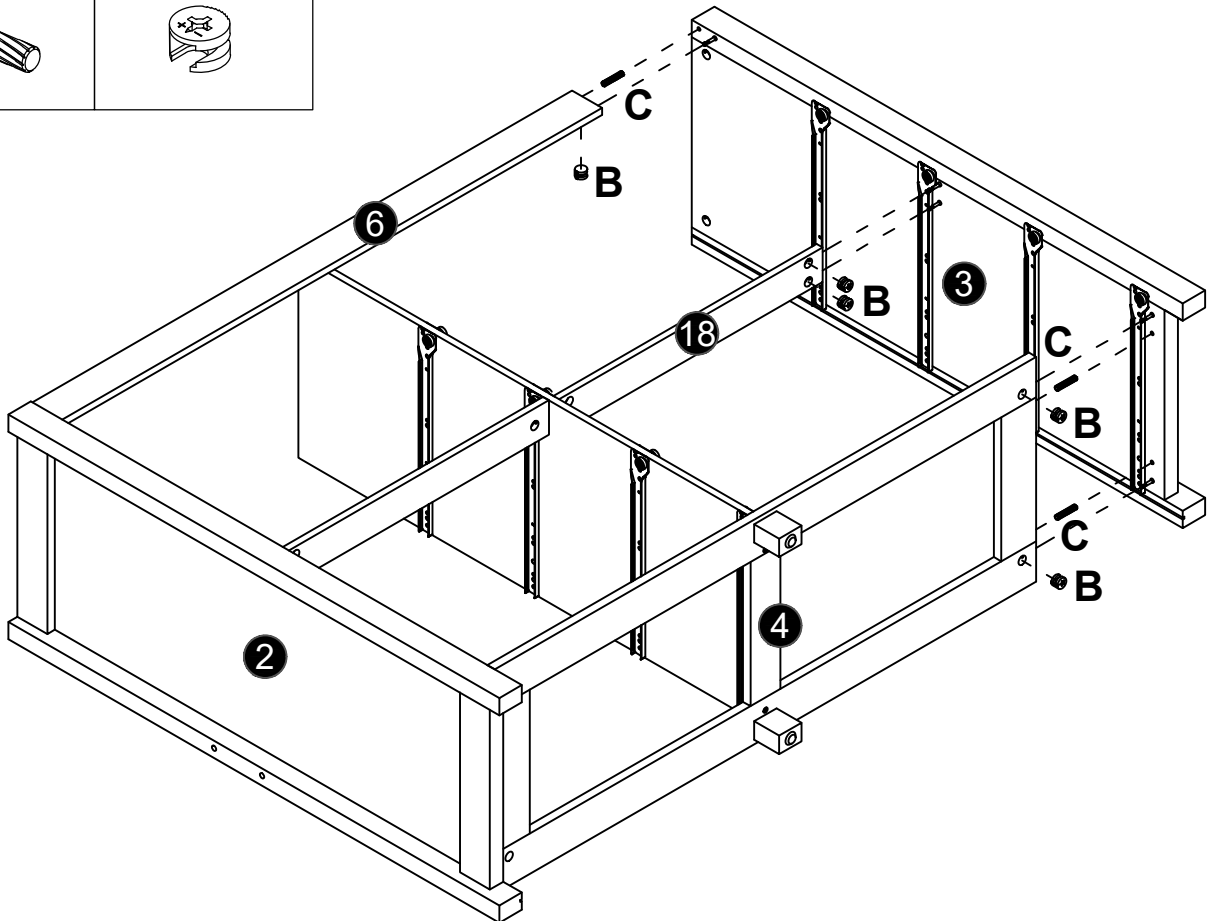
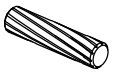

E x2



M x1

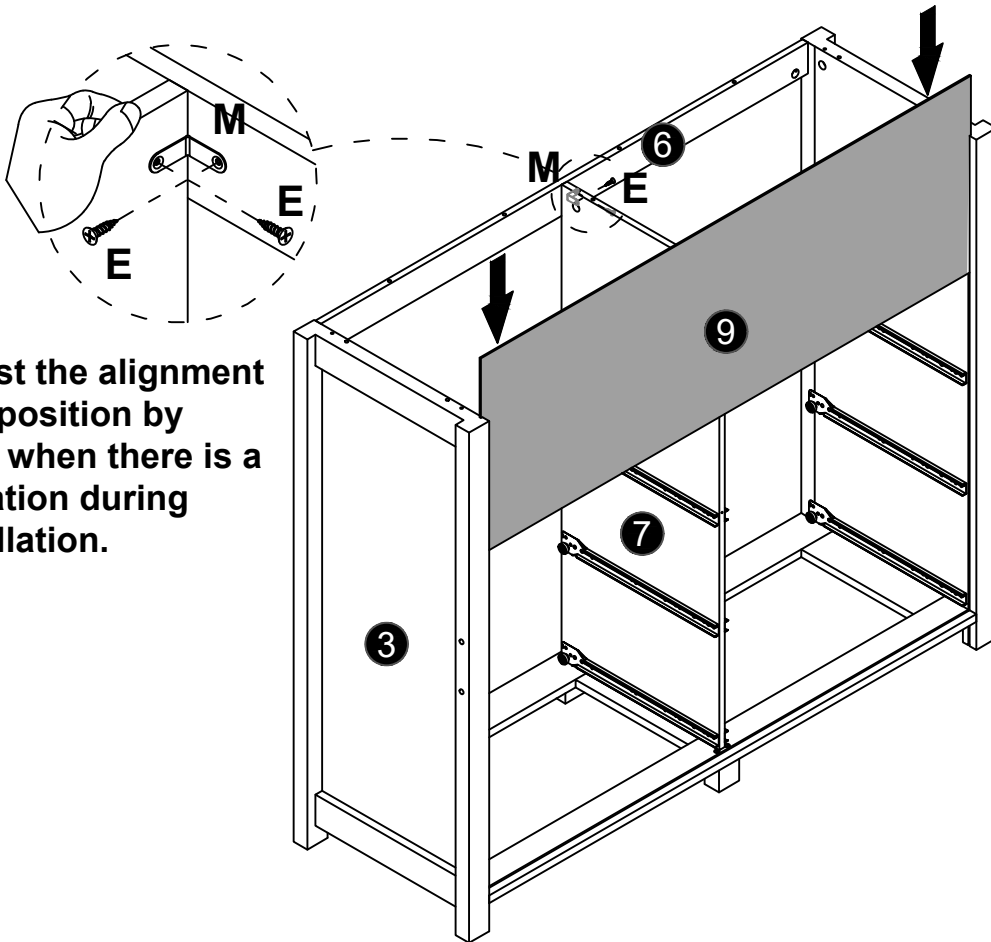
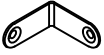

Adjust the alignment hole position by hand when there is a deviation during installation.

D x1

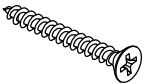

F x4

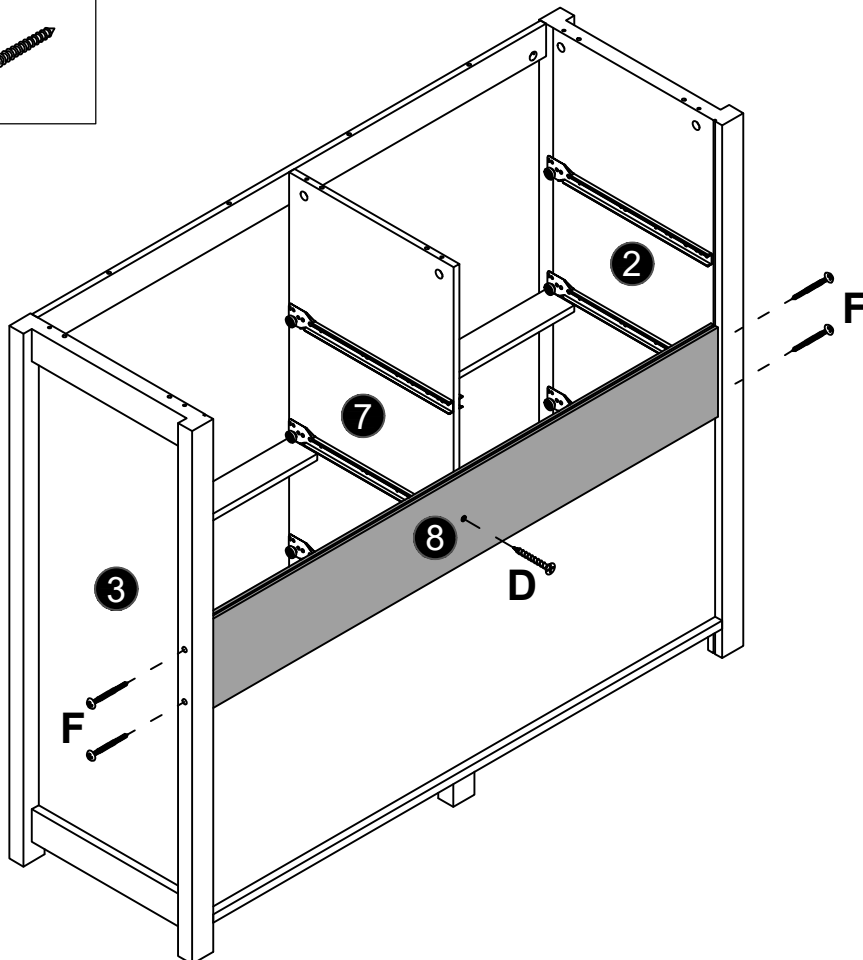

C x10

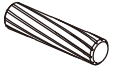

13

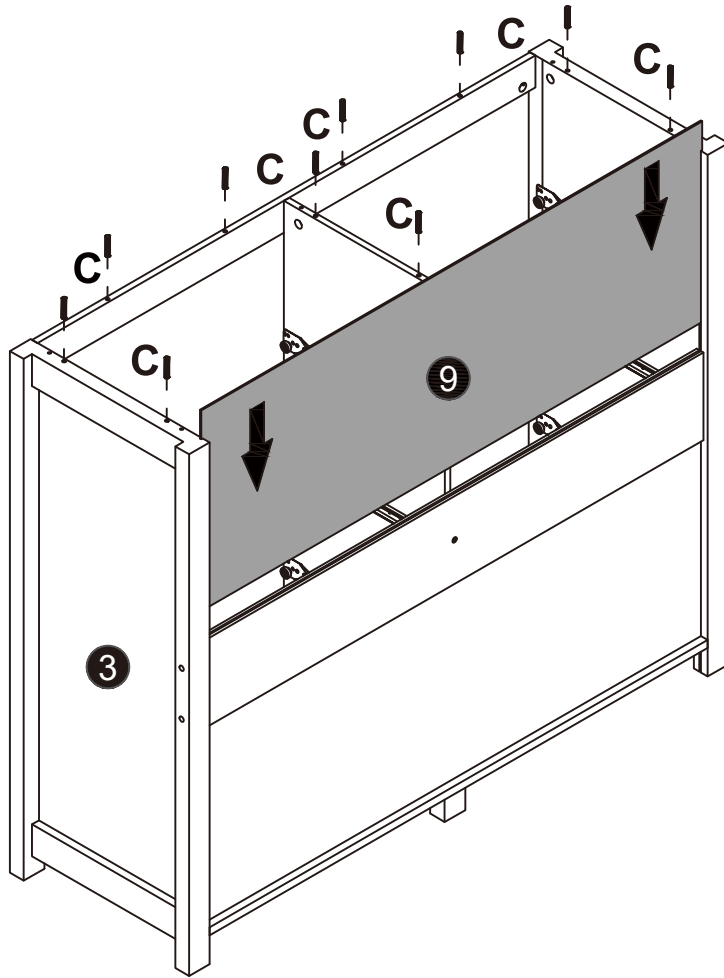

A x6

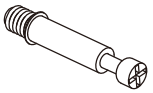

14

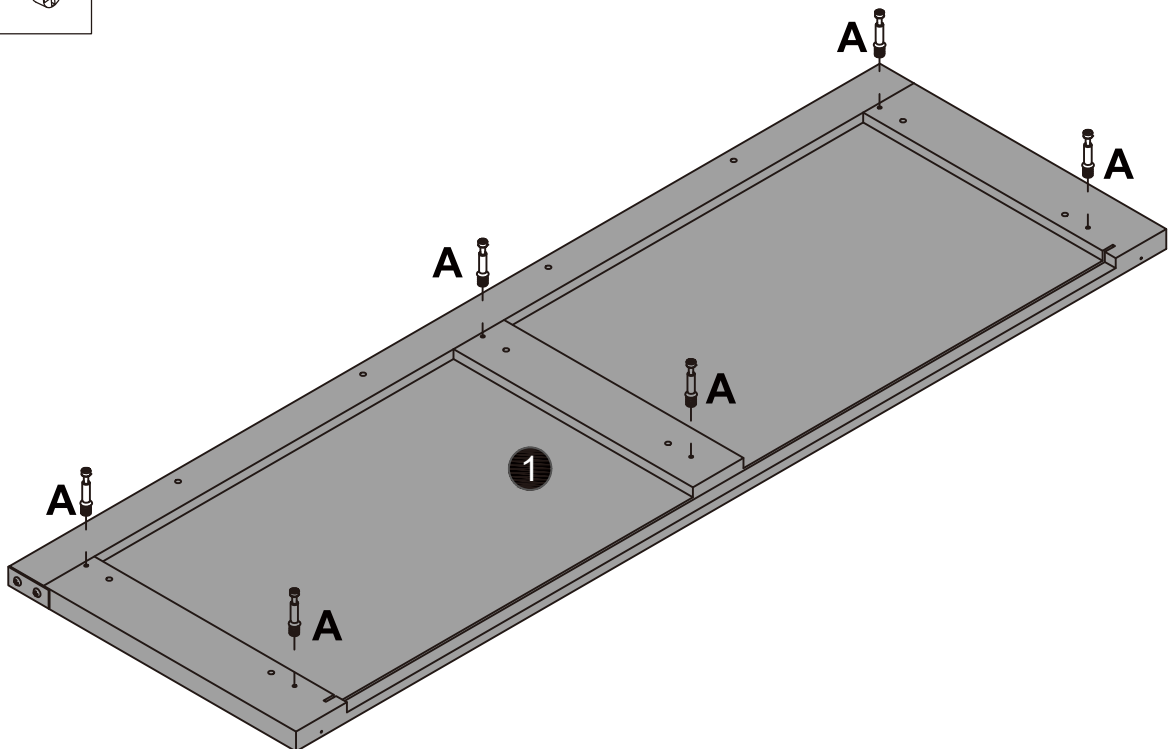

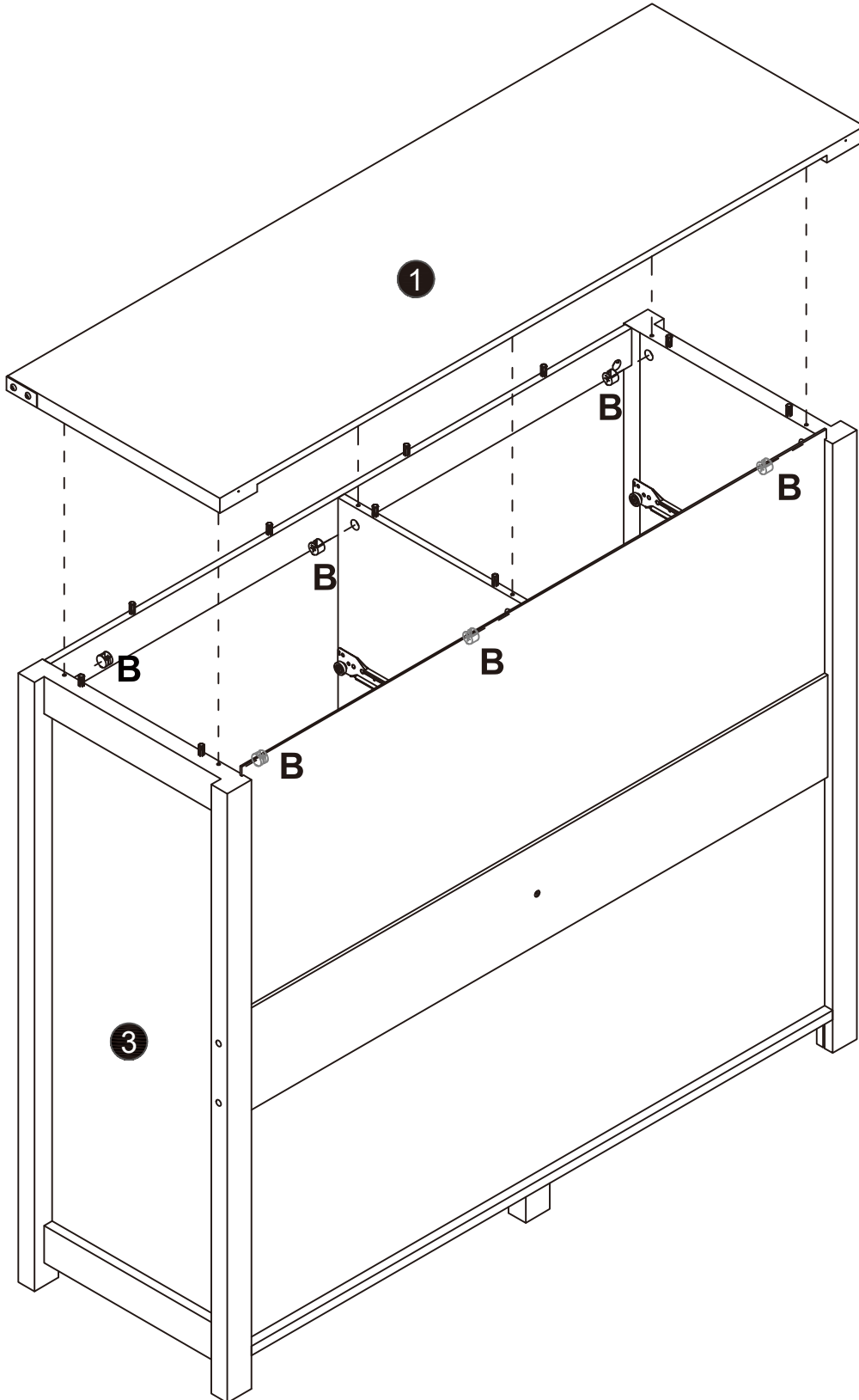

J x12

G x4



J-1



J-2

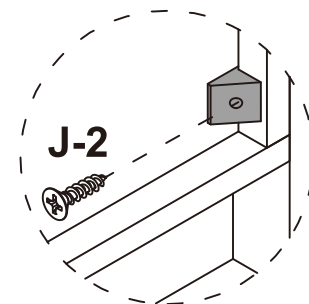
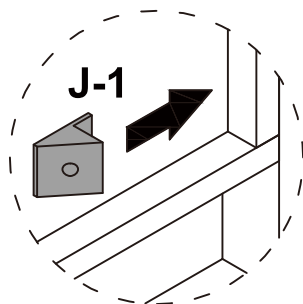
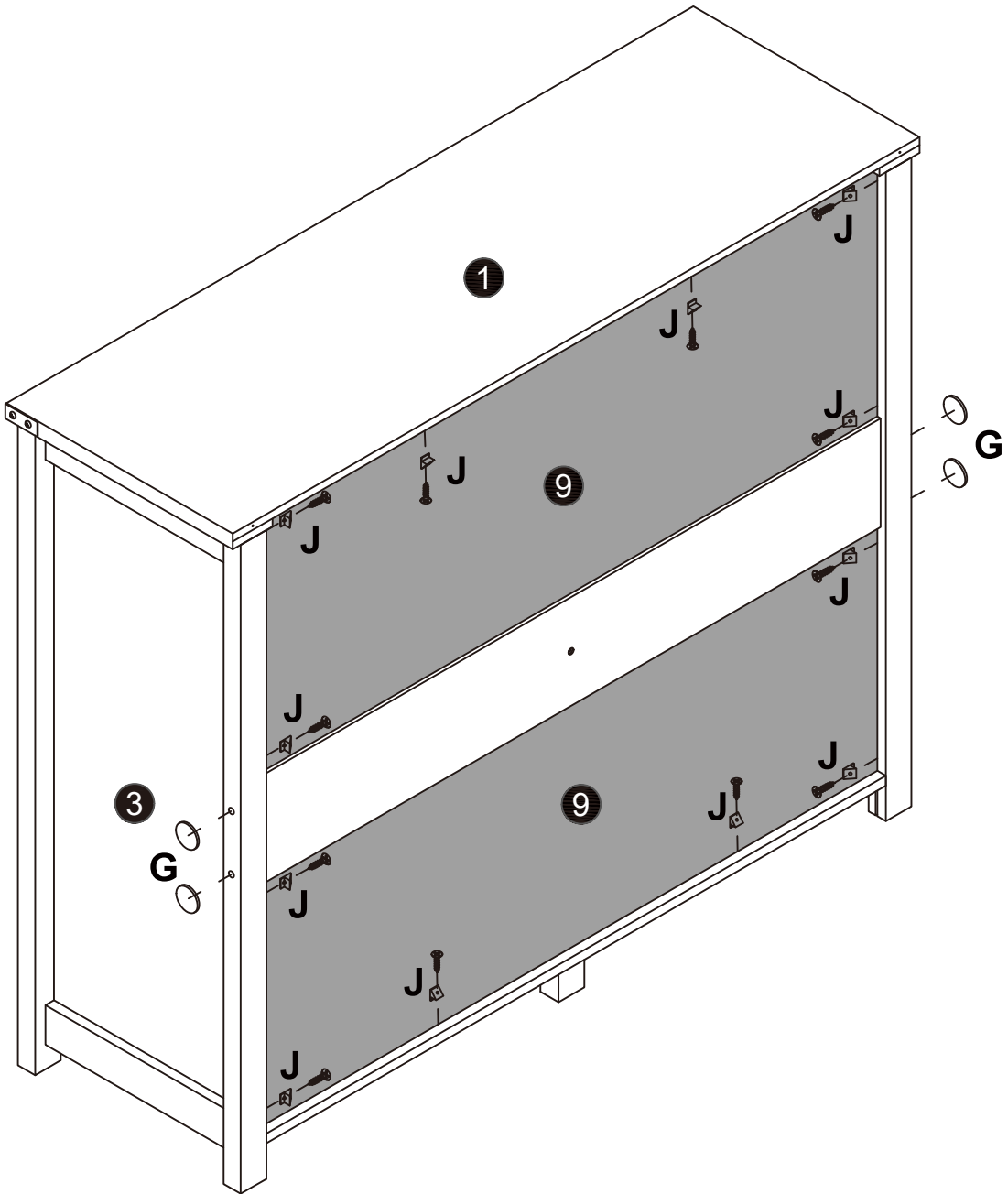

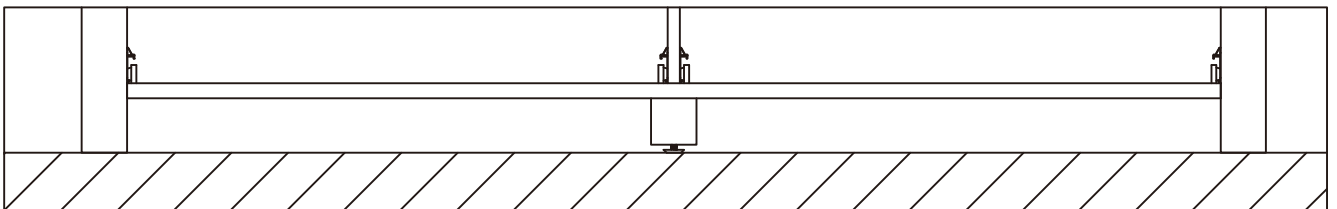
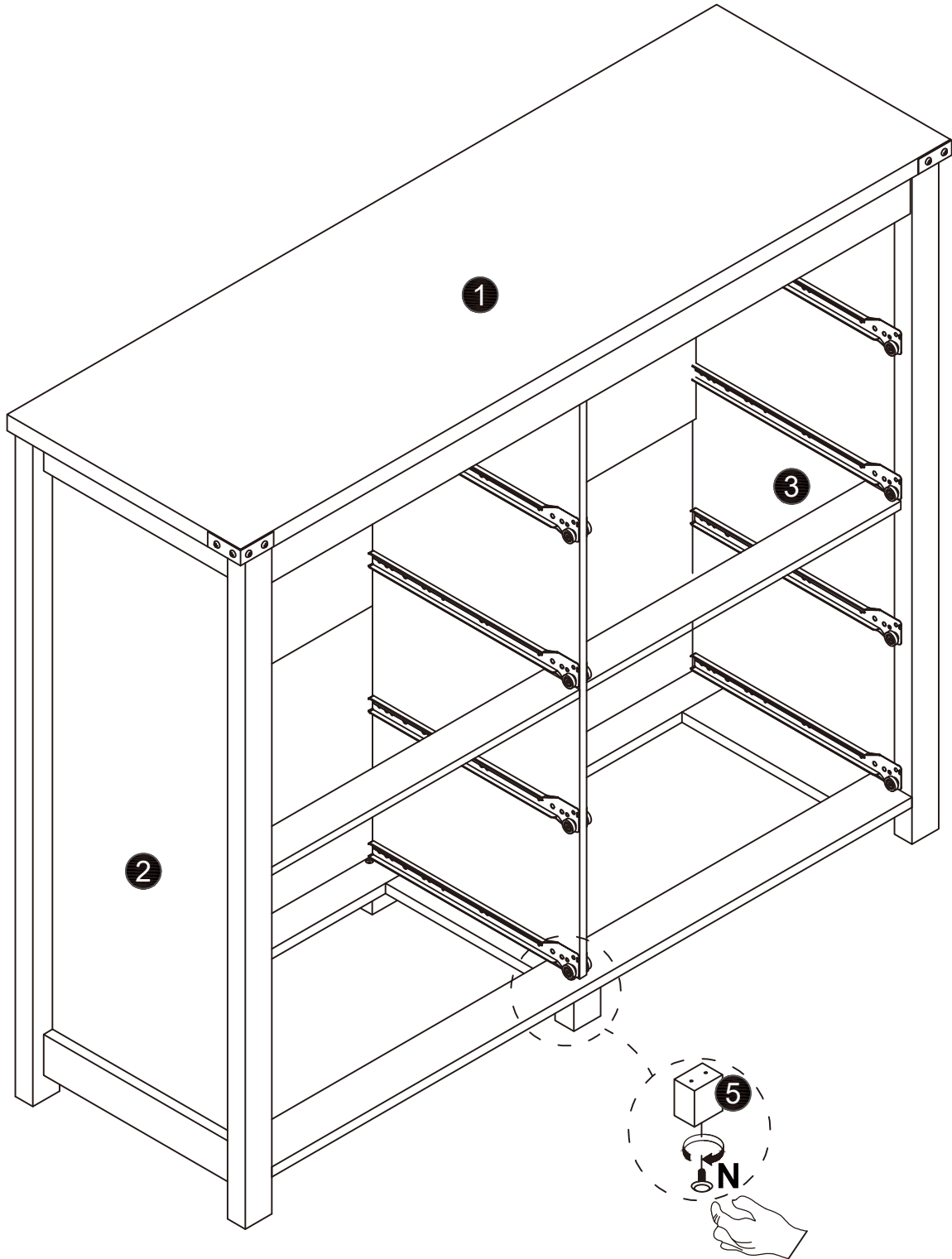

**If the cabinet is unstable on the ground, please rotate the No. N adjustment foot pad on the No. 5 support leg.**

**Attention:** The drawer is divided into left drawer and right drawer.



The picture shows the left drawer installed in the cabinet.

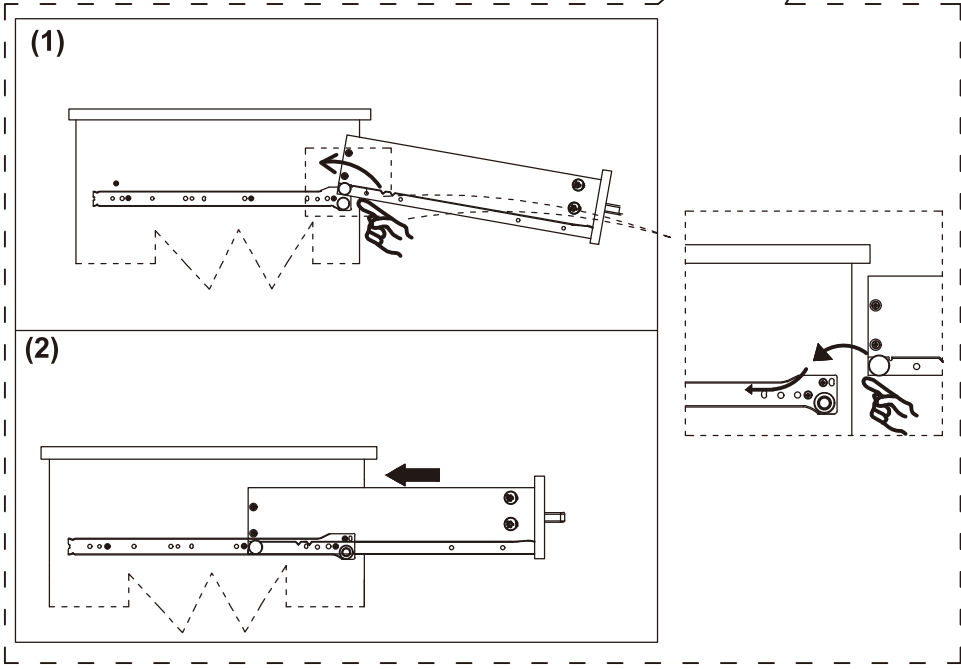
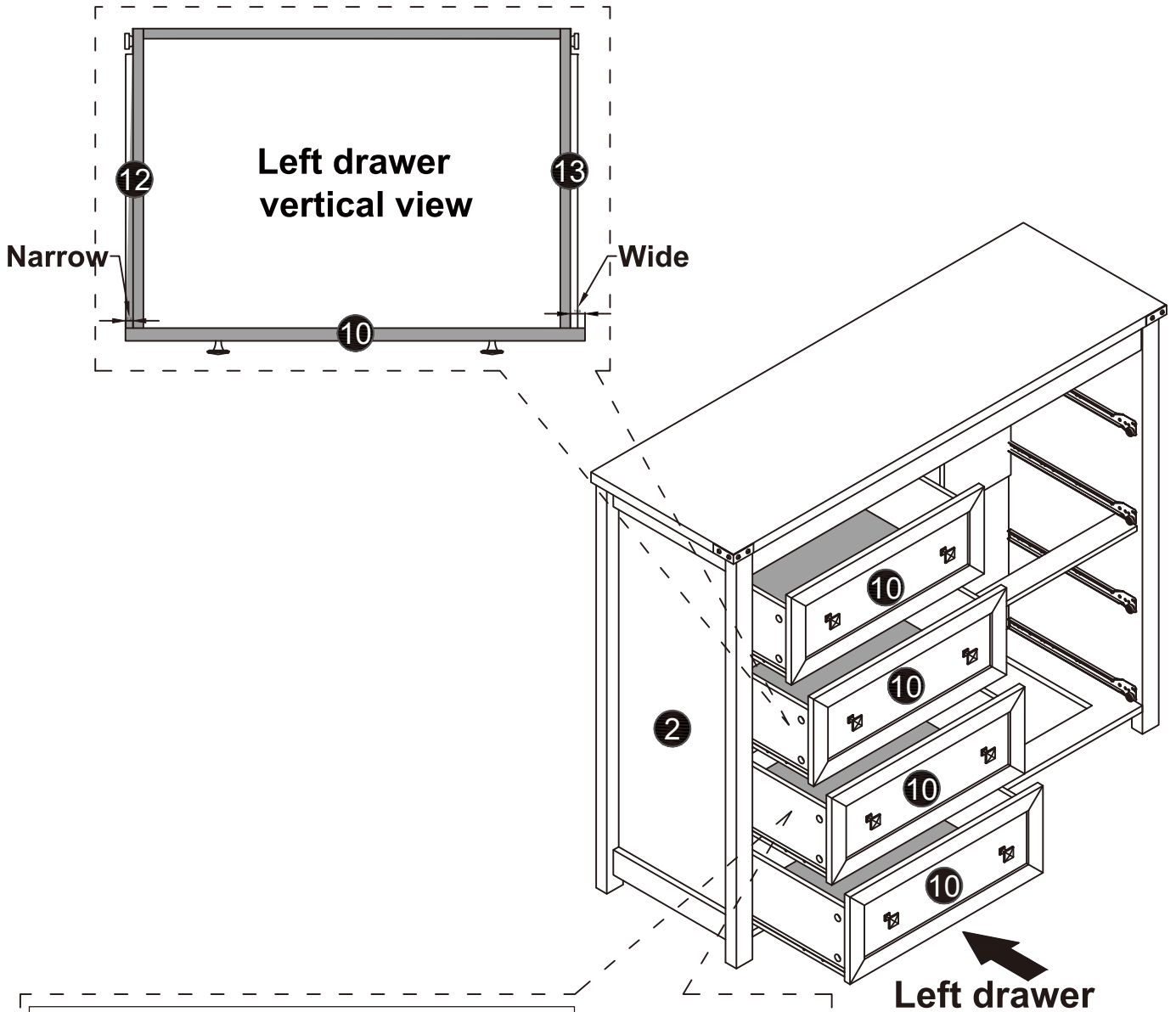

**Attention: The drawer is divided into left drawer and right drawer.**



**The picture shows the Right drawer installed in the cabinet.**

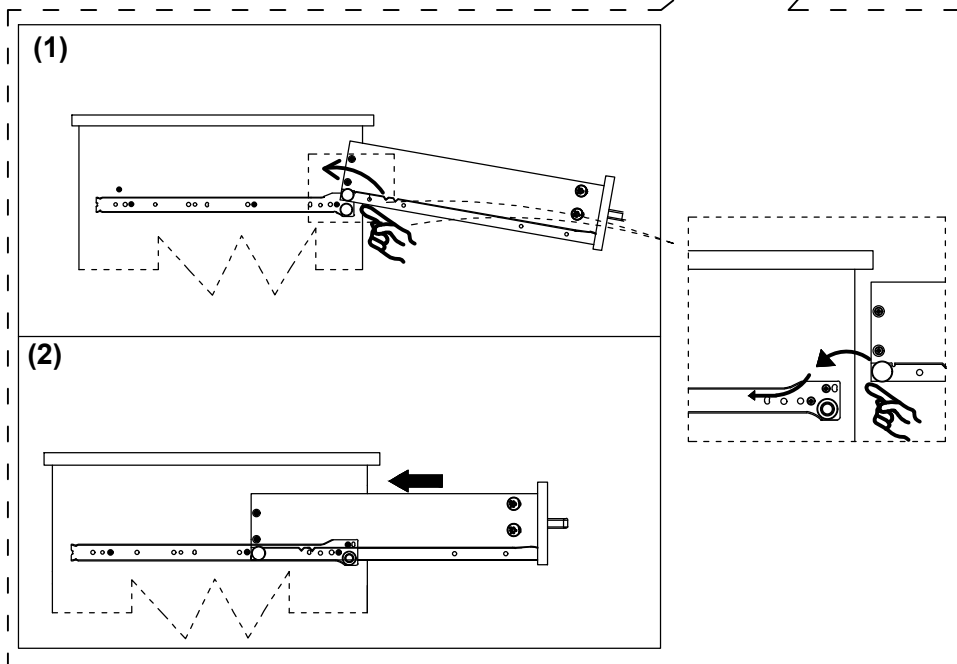
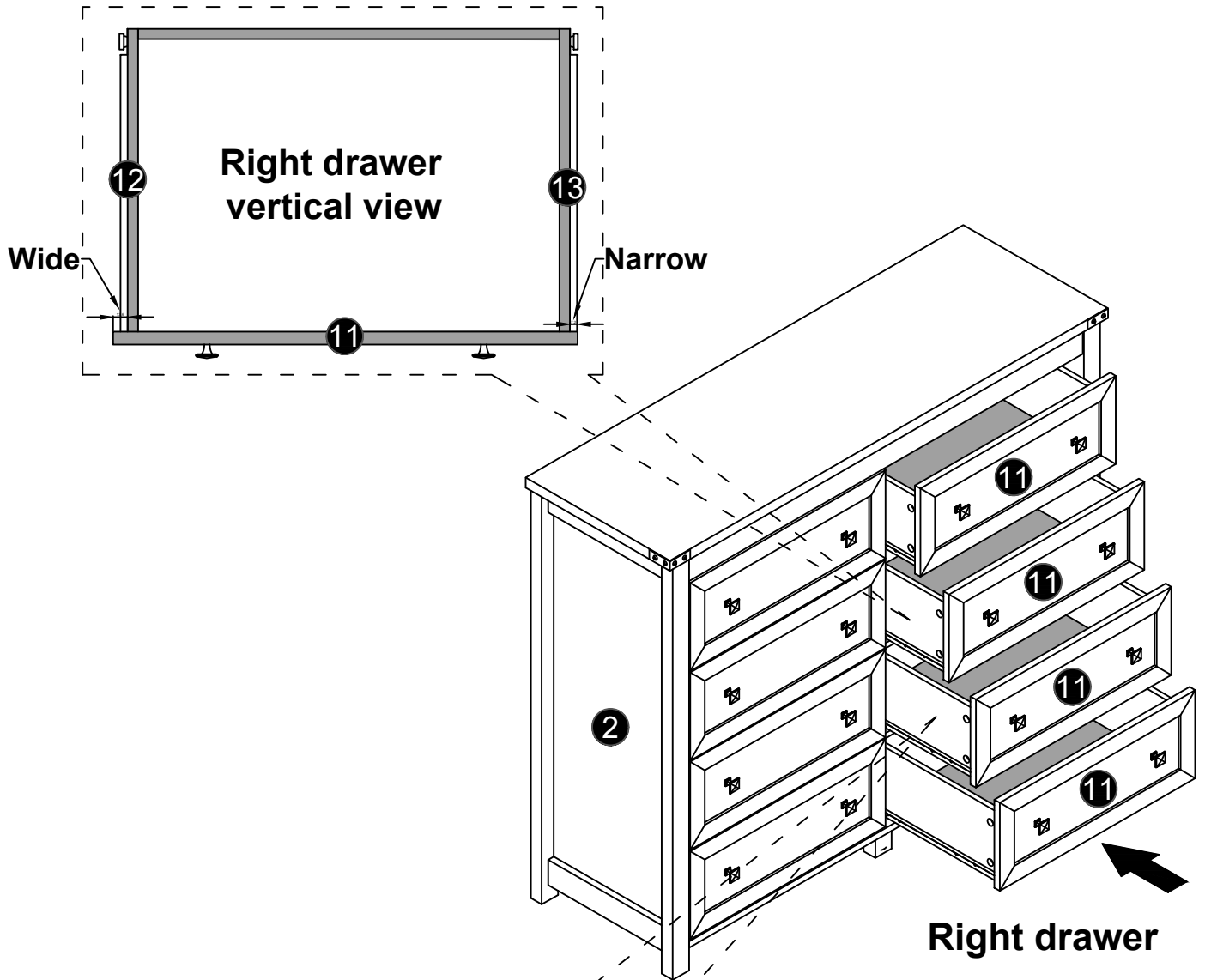

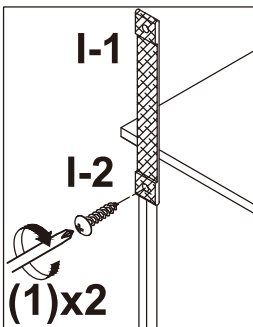
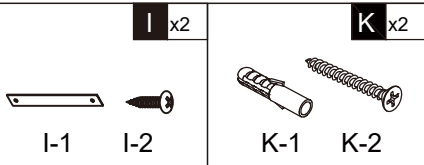

First fix the anti-rewind screw in the reserved hole of the product.

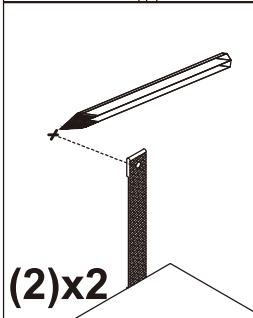

then, use a ruler to measure the approximate height of the product on the wall, and then mark it with a pen.

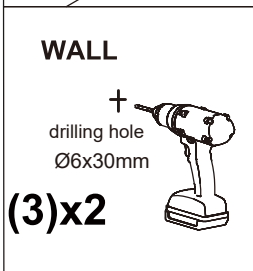

Then use a tape drill to make holes in the wall that are suitable for the product screws.

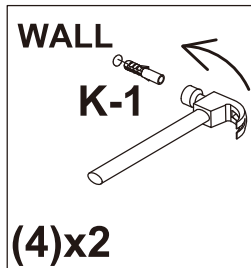

Then, put the expansion bolt into the hole

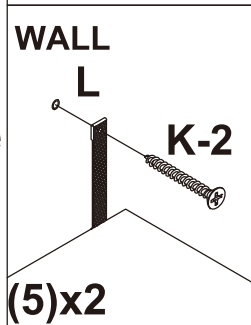

Finally, pass the matching screws through the "anti-rewind" and tighten them to fix them on the wall.

