

ASSEMBLY INSTRUCTION



Assembly Instruction

ASSEMBLY TIPS:

1. Remove hardware from box and sort by size.
2. Please check to see that all hardware and parts are present prior to start of assembly.
3. Please follow attached instructions in the same sequence as numbered to assure fast & easy assembly.

Warning!

1. Don't attempt to repair or modify parts that are broken or defective. Please contact the store immediately.
2. This product is for home use only and not intended for commercial establishment.

PARTS IDENTIFICATION: Z HARDWARE PACKAGE

(A) BACK  1PC

(B) SEAT  1PC

(C) RIGHT ARM  1PC

(D) LEFT ARM  1PC



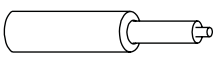

(E) ADJUSTING PLATE  1PC

(F) COVER FOR GAS LIFT  1PC

(G) GAS LIFT  1PC

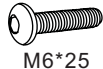
(H) BASE  1PC

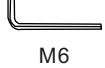
(I) CASTER  5PCS

NO	DESCRIPTION	FIGURE	Q'TY
1	LONG BOLT	 M6*25	8PCS
2	SHORT BOLT	 M6*20	4PCS
3	ALLEN WRENCH	 M6	1PC
4	CAP		8PCS
5	WASHER	 M6*18*1.2	4PCS

STEP 1

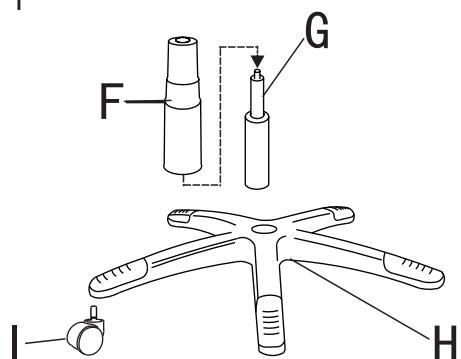

STEP 2

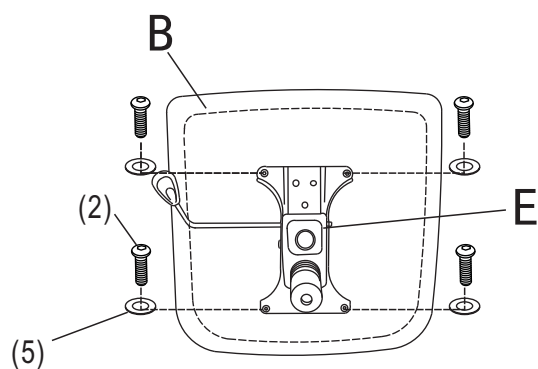

STEP 3

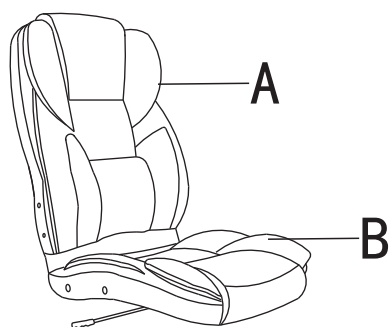

STEP 4

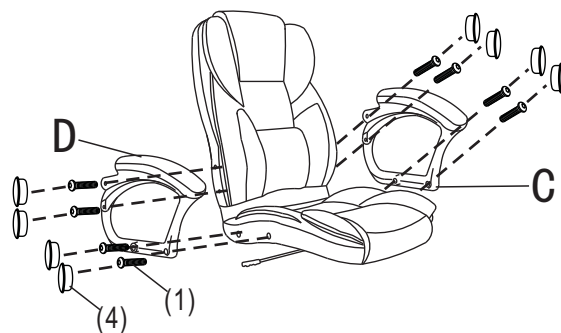

STEP 5

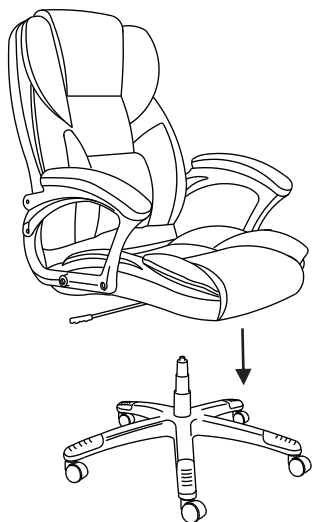

STEP 6

