

*2

Single back

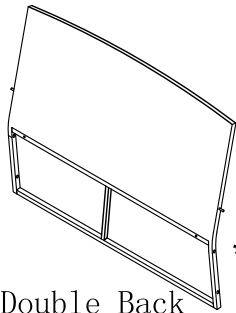

*1

Double Back

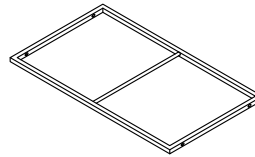

*1

Table base

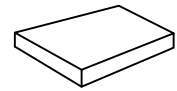

Assembly bag

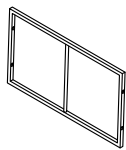

*2

Single Front Panel

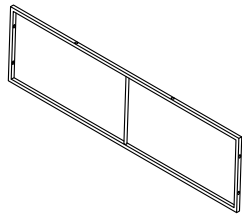

*1

double front panel

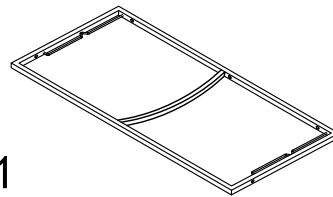

*1

Double Seat Base

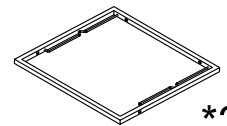

*2

Single Seat Base

**Carton
1/3**

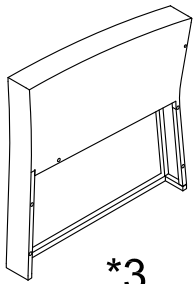

*3

Right Arm

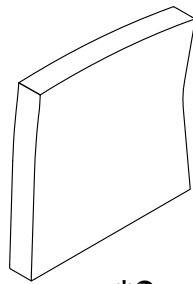

*3

Left Arm

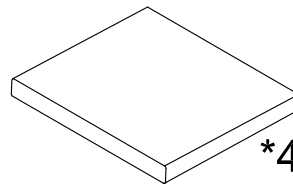

*4

Seat Cushion

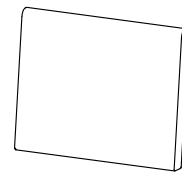

*2

Back Cushion

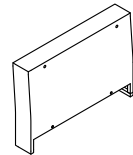

*2

Table leg



*2

Pillow

**Carton
2/3**

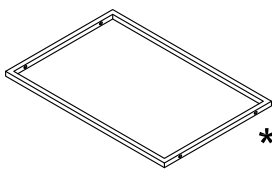

*1

Table Top

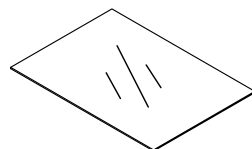

*1



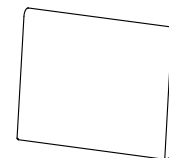

Glass top





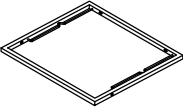

*2

Back Cushion

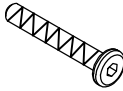
**Carton
3/3**

Item no.	Reference Image	Description	Qty.
A		Left Arm	1
B		Right Arm	1
C		Single back	1
D		Seat base	1
E		Front Panel	1

Item no.	Reference Image	Description	Qty.
F		Leveling Foot	4
G		M6*50 Socket Head Cap Screw	10
H		M6*30 Socket Head Cap Screw	2
J		Nut	10
K		Flat Washer	22

TOOL LIST

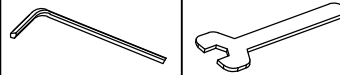

Single Sofa

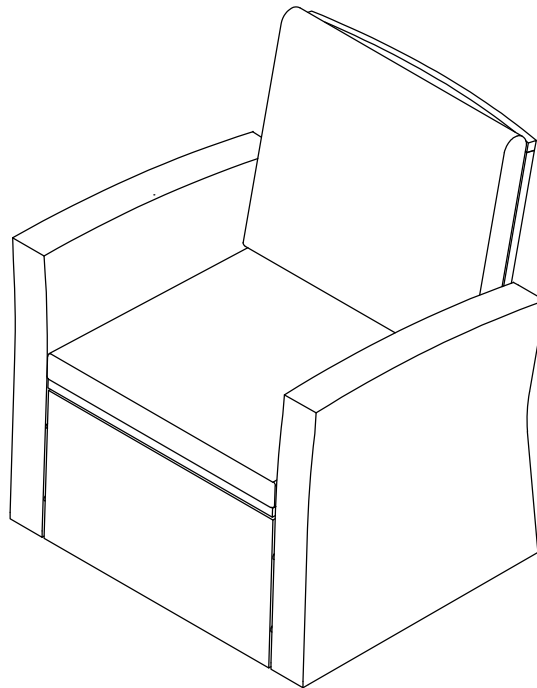

DO not fully tighten all screws until assembly is completed.

1

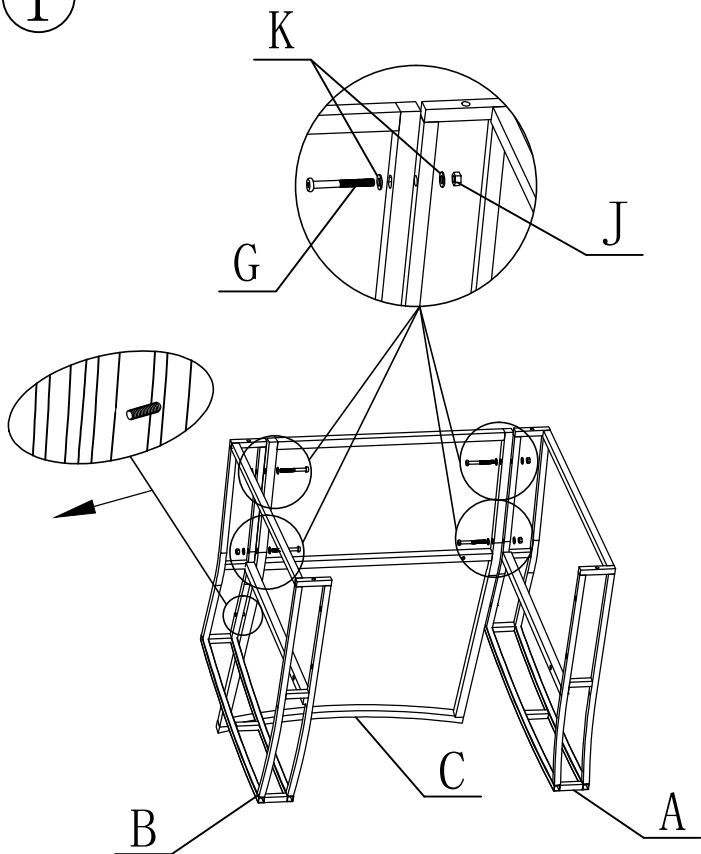

2

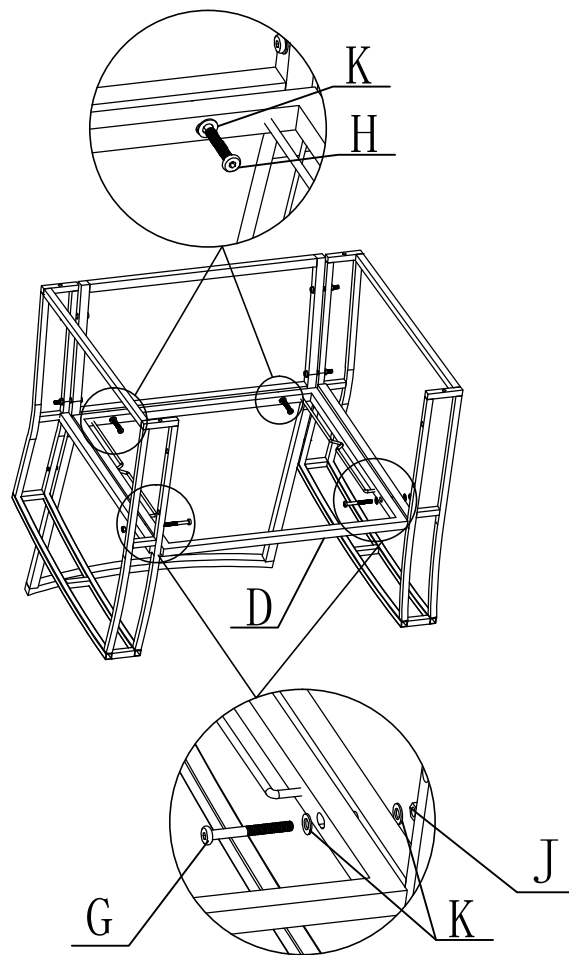



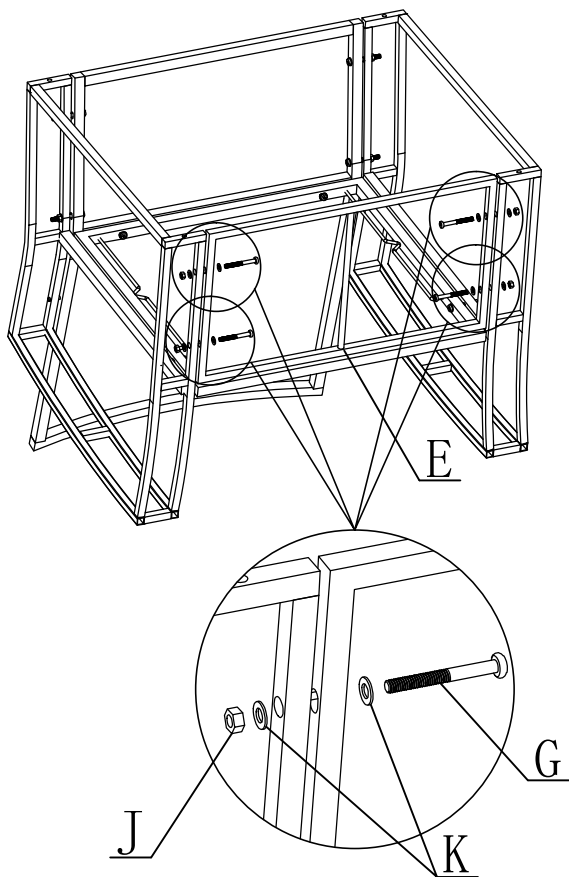

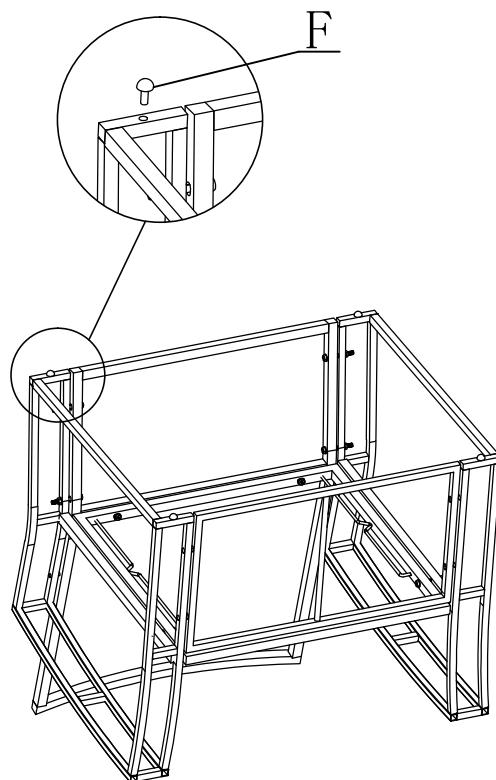

3

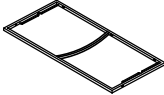
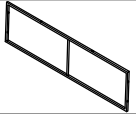

4

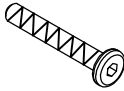
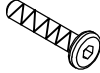

Item no.	Reference Image	Description	Qty.
A		Left Arm	1
B		Right Arm	1
C		Back	1
D		Seat base	1
E		Front Panel	1

Item no.	Reference Image	Description	Qty.
F		Leveling Foot	4
G		M6*50 Socket Head Cap Screw	10
H		M6*30 Socket Head Cap Screw	5
J		Nut	10
K		Flat Washer	25

TOOL LIST

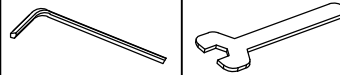

Duble Sofa

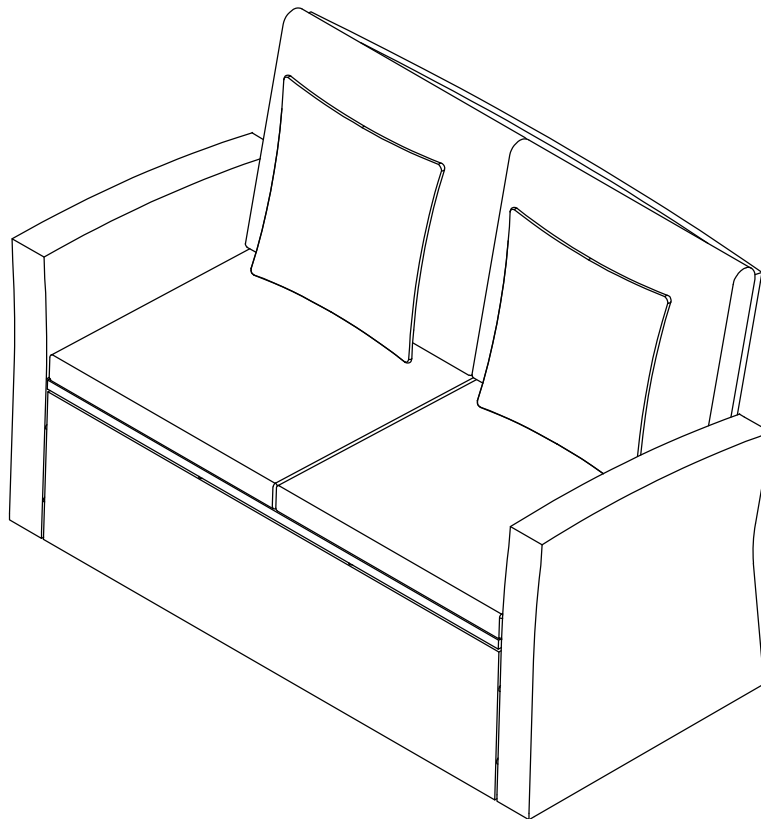

DO not fully tighten all screws until assembly is completed.

1

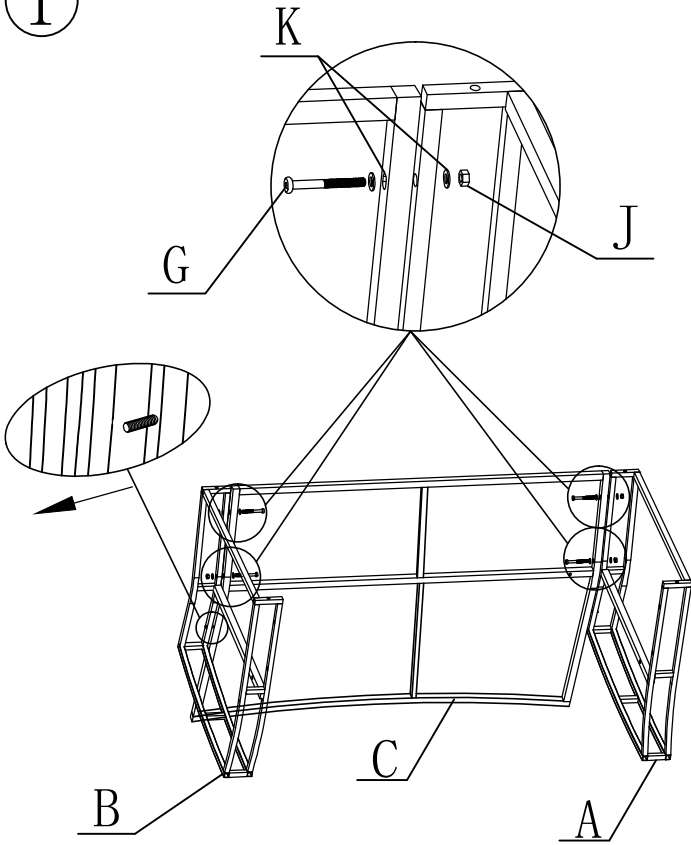

2

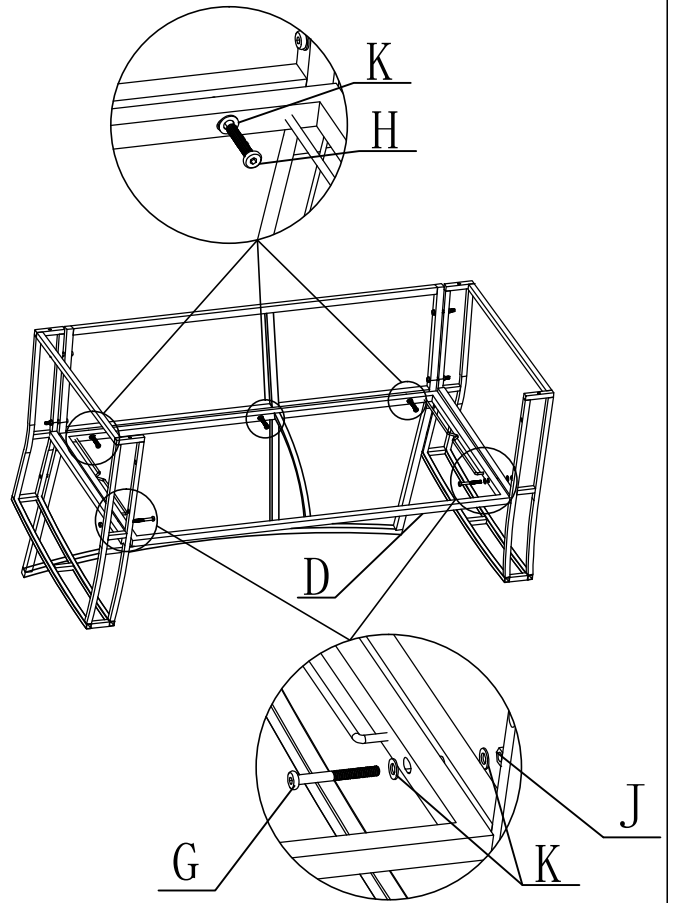



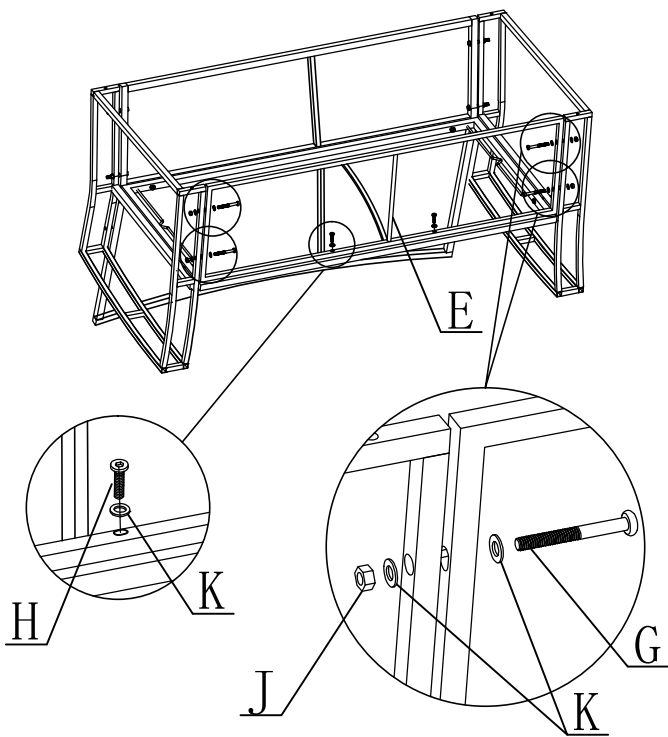

3

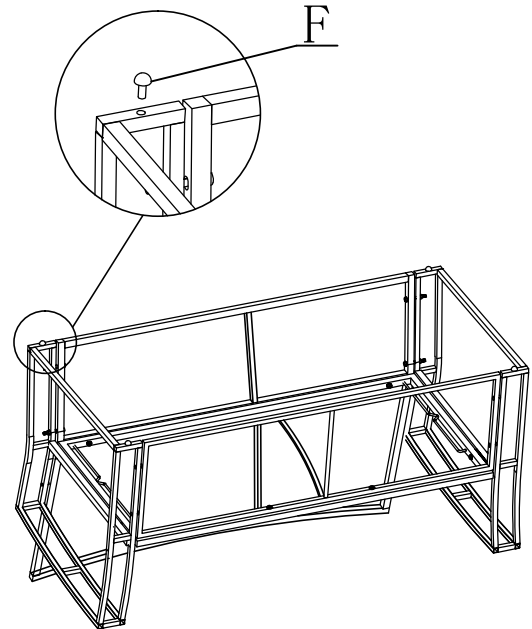

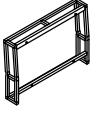
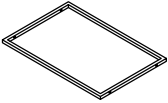
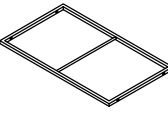
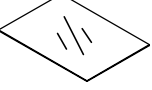
4



Item no.	Reference Image	Description	Qty.
A		Table leg	2
B		Table top	1
C		Table base	1
D		Glass Top	1

Item no.	Reference Image	Description	Qty.
E		Leveling Foot	4
F		M6*30 Socket Head Cap Screw	8
G		Flat Washer	8
TOOL LIST			
			

Coffee Table

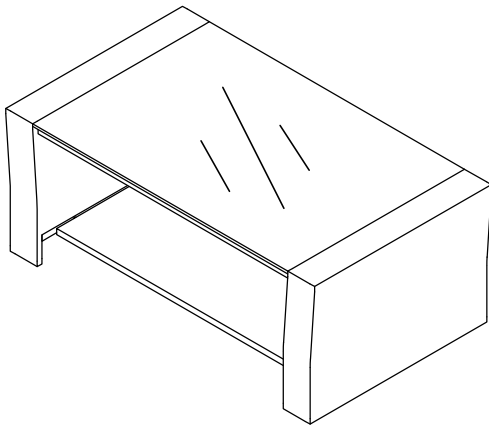

DO not fully tighten all screws until assembly is completed.

