

A

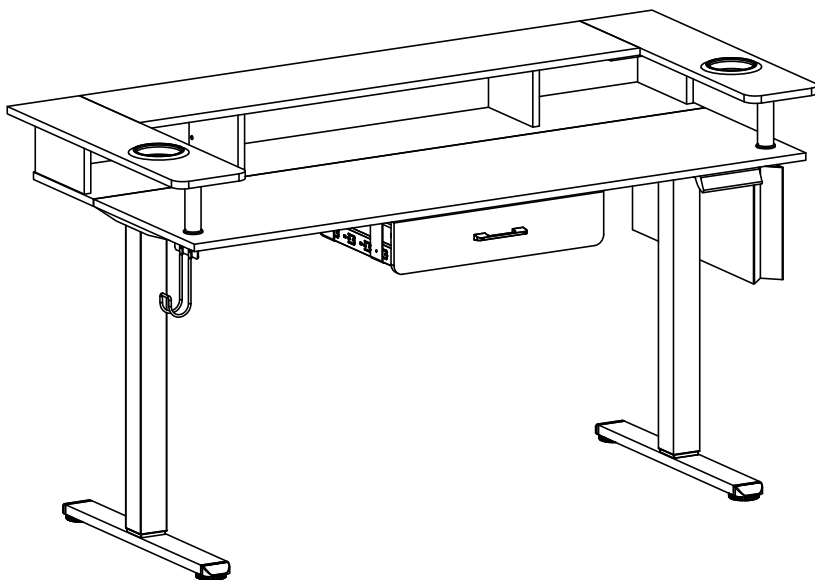

B

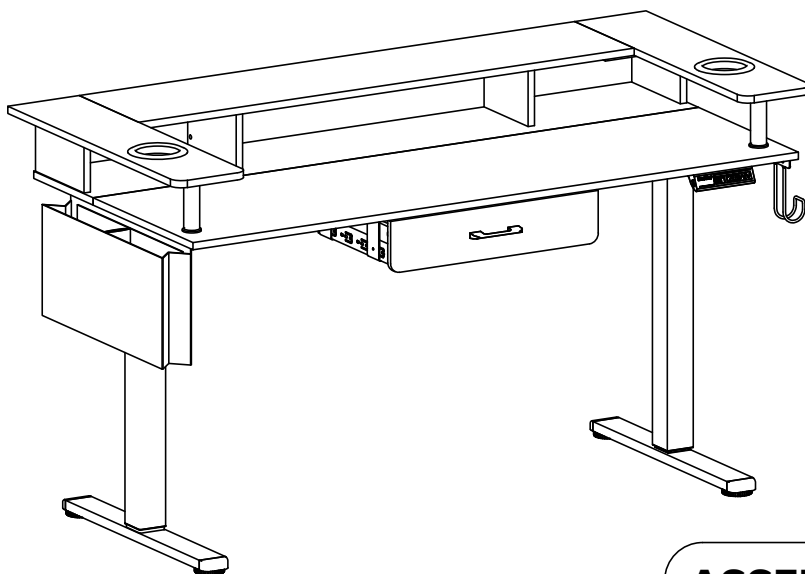

ASSEMBLY INSTRUCTION

Montageanleitung
Instructions De Montage
Istruzioni Per L'assemblaggio
Instrucciones De Montaje
組立説明書
安裝說明書



HELPFUL HINTS

BEFORE YOU START

- Inspect product packaging to ensure the appearance is good.
- Read the assembly instruction carefully and follow it step by step.
- To avoid any scratching, putting a soft blanket on the floor is suggested.
- Identify, sort and count all the parts with tags.
- Find out installation position according to the drawing and install it in correct steps.

OTHER

- People needed for assembly: 1-2.
- Estimated assembly time: 1-1.5h.

CAUTION

- Be cautious when using a power drill or power screwdriver.
- Please be aware to slow down and stop when screw is nearly tight.
- Do Not use any harsh chemicals or abrasive cleaners for this item.
- Push, pull or drag this item carefully.

ASTUCES UTILES

AVANT DE COMMENCER

- Inspectez l'emballage du produit pour vous assurer que l'apparence est bonne.
- Lisez attentivement les instructions de montage et suivez-les étape par étape.
- Pour éviter toute rayure, posez une couverture douce sur le sol est suggéré.
- Identifiez, triez et comptez toutes les pièces avec des étiquettes.
- Trouver la position d'installation selon le dessin et l'installer dans les étapes correctes.

AUTRE

- Personnes nécessaires pour l'assemblage : 1-2.
- Temps de montage estimé : 1-1.5 h.

AVERTIR

- Soyez prudent lorsque vous utilisez une perceuse électrique ou un tournevis électrique.
- Veuillez être conscient de ralentir et d'arrêter lorsque la vis est presque serrée.
- N'utilisez pas de produits chimiques corrosifs ou de nettoyeurs abrasifs pour cet article.
- Poussez, tirez ou tirez cet article avec précaution.

CONSEJOS ÚTILES

ANTES DE EMPEZAR

- Inspeccione el paquete del producto para asegurarse de que la apariencia es buena.
- Lea atentamente las instrucciones de montaje y sígalas paso a paso.
- Para evitar rayas, se sugiere poner una manta suave en el suelo.
- Identifique, clasifique y enumere todas las piezas con etiquetas.
- Averigüe la posición de instalación según el dibujo e instálela en los pasos correctos.

OTROS

- Personas necesarias para el montaje: 1-2.
- Tiempo de montaje estimado: 1-1.5 h.

PRECAUCIÓN

- Tenga cuidado al utilizar un taladro eléctrico o un destornillador eléctrico.
- Tenga en cuenta que debe hacerlo más despacio y detenerse cuando el tornillo esté casi apretado.
- No utilice productos químicos agresivos ni limpiadores abrasivos para este artículo.
- Empuje, tire o arrastre este elemento con cuidado.

SUGGERIMENTI UTILI

PRIMA DI INIZIARE

- Controllare la confezione del prodotto per assicurarsi che sia in buono stato.
- Leggere con attenzione le istruzioni per l'assemblaggio e seguirle passo dopo passo.
- Per evitare graffi al pavimento, suggeriamo di stendervi una coperta morbida.
- Identificare, suddividere e contare tutte le parti con etichetta.
- Trovare la posizione adatta per il montaggio in base al disegno e montare lo scaffale seguendo correttamente i vari passaggi.

ALTRO

- Persone necessarie per l'assemblaggio: 1-2.
- Tempo di assemblaggio stimato: 1-1.5 ora.

ATTENZIONE

- Prestare molta attenzione quando si utilizza un trapano elettrico o un cacciavite elettrico.
- Rallentare con accortezza e fermarsi quando una vite è già sufficientemente serrata.
- Non utilizzare prodotti chimici aggressivi o detergenti abrasivi su questo articolo.
- Spingere, tirare o trascinare questo articolo con cautela.

NÜTZLICHE HINWEISE

⚠️ BEVOR SIE BEGINNEN

- Überprüfen Sie die Produktverpackung auf Schäden.
- Lesen Sie sich die Montageanleitung sorgfältig durch und befolgen Sie sie Schritt für Schritt.
- Um etwaiges Zerkratzen zu vermeiden, wird das Auslegen einer weichen Decke auf dem Boden empfohlen.
- Identifizieren, sortieren und zählen Sie alle Teile mit Tags nach.
- Identifizieren Sie die Montageposition gemäß der Zeichnung und bauen Sie das Regal den richtigen Schritten entsprechend auf.



SONSTIGES

- Für den Zusammenbau erforderliche Anzahl an Menschen: 1-2.
- Ungefähre Montagedauer: 1-1.5 h.

⚠️ VORSICHT

- Seien Sie bei der Verwendung einer Bohrmaschine oder eines Akkuschraubers vorsichtig.
- Bitte vergessen Sie nicht darauf, langsamer zu werden und zu stoppen, sobald die Schraube fast festgezogen ist.
- Verwenden Sie keinerlei aggressive Chemikalien oder scheuernden Reinigungsmittel für dieses Produkt.
- Schieben oder ziehen Sie dieses Produkt vorsichtig.

温馨提示

⚠️ 组立前说明

- 检查产品包装，确保外观良好。
- 仔细阅读组装说明，并按步骤操作。
- 为了避免任何刮伤，建议在地板上放一条柔软的毯子。
- 用标签识别、分类和计数所有部件。
- 根据图纸找到安装位置，按正确步骤安装。



其他:

- 组装所需人员: 1-2人。
- 预计组装时间: 1-1.5小时。

⚠️ 注意:

- 建议优先使用电动螺丝刀组装, 使用电钻或电动螺丝刀时请谨慎。
- 当螺丝快要拧紧时, 请注意减速并停止。
- 不要使用任何粗糙的化学物质或研磨清洁剂。
- 小心地推、拉或拖此产品。

役に立つヒント

⚠️ 組立の場所を確保し、順番通りに組み立てる

- 組立場所 (充分広くて平たい場 所) を確保してください。
- 床や壁、商品を傷つけないように、商品の下に厚めの布や段ボールなどを敷いてください。
- 組立の順番を守らないと、組立できなくなったり、商品を傷つけたりします。



その他

- 組み立てに必要な人: 1-2。
- 組立時間: 約1~1.5時間。

⚠️ 部品を確認する

- ネジ類などの部品番号、形状を説明書の部品一覧で確認してください。
- 部品をなくさないように纏めて置いてください。
- 部品を取り出すときに使う分だけ取り出してください。

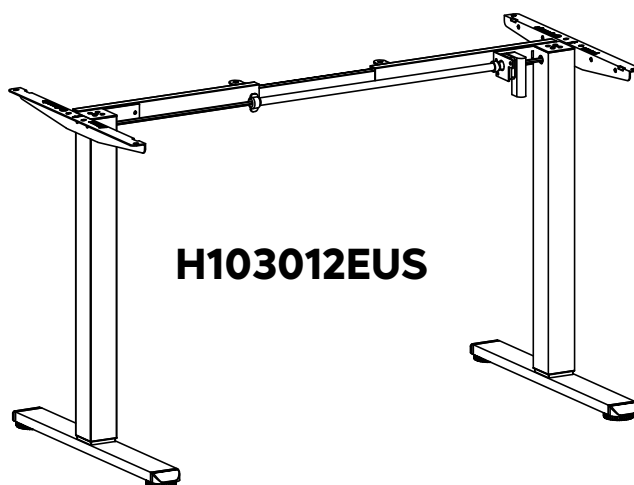

⚡ Power Input 100V-240V

- Entrée d'alimentation 100V-240V
- Eingangsleistung 100V-240V
- Alimentazione 100V-240V
- Potencia de entrada: 100-240 V
- 電源入力100V~240V
- 功率輸入 100V-240V

⚡ Speed 20 mm/s

- Vitesse 20 mm/s
- Geschwindigkeit 20 mm/s
- Velocità 20 mm/s
- Velocidad: 20 mm/s
- 速度20mm/s
- 速度20mm/s

🔊 Motion Noise < 55dB

- Bruit de mouvement < 55dB
- Bewegungsgeräusch < 55dB
- Rumore in movimento < 55dB
- Ruido de movimiento: < 55 dB
- 動作ノイズ < 55dB
- 运动噪音 < 55dB

📦 Load Capability 154 lbs / 70 kg

- Capacité de charge 154 lbs / 70 kg
- Ladekapazität 154 Pfunde / 70 kg
- Capacità di carico 154 lbs / 70 kg
- Capacidad de carga: 70 kg (154 libras)
- 最大負荷 154 lbs/ 70 kg
- 负载能力 154 lbs / 70 kg

- 3 Height Position Memory
- Vertical Range: 72-118cm
- Desk top Dimensions: 95-135cm

- | | | |
|---|--|--|
| <ul style="list-style-type: none">• 3 Mémoire de la position en hauteur• Plage verticale : 72-118 cm• Dimensions du dessus de table : 95-135 cm | <ul style="list-style-type: none">• 3 posizioni di altezza memorizzabili• Gamma di altezza verticale: 72 - 118 cm• Dimensioni del piano della scrivania: 95-135 cm | <ul style="list-style-type: none">• 3つの高さ調整メモリ• 高さの範囲: 72~118 cm• デスクトップの寸法: 95-135 cm |
| <ul style="list-style-type: none">• Speicherung von 3 Höhenpositionen• Vertikaler Bereich: 72-118 cm• Tischplatte Abmessungen: 95-135 cm | <ul style="list-style-type: none">• Memoria de 3 posiciones de altura• Alcance vertical: 72-118 cm• Tamaño de mesa: 95-135 cm | <ul style="list-style-type: none">• 3 高度位置记忆• 高度范围: 72-118 cm• 桌面尺寸: 95-135 厘米 |

• CAUTION: DO NOT EXCEED MAXIMUM LISTED WEIGHT CAPACITY.SERIOUS INJURY OR PROPERTY DAMAGE MAY OCCUR!

- ATTENTION : NE PAS DEPASSER LA CAPACITE DE CHARGE MAXIMALE INDIQUEE. DES BLESSURES GRAVES OU DES DOMMAGES MATERIELS PEUVENT SURVENIR !
- ACHTUNG: ÜBERSCHREITEN SIE NICHT DIE ANGEGEBENE GEWICHTSKAPAZITÄT., UM SCHWERE VERLETZUNGEN ODER SACHSCHÄDEN ZU VERMEIDEN!
- ATTENZIONE: NON SUPERARE IL CARICO MASSIMO CONSENTITO: RISCHIO DI GRAVI DANNI A COSE E PERSONE!
- PRECACUIÓN: ¡NO SE DEBE EXCEDER LA CAPACIDAD DE PESO MÁXIMA QUE HEMOS MENCIONADO, DE LO CONTRARIO PODRÍA PRODUCIR LESIONES GRAVES O DAÑOS A LA PROPIEDAD!
- 注意: 記載されている最大負荷を超えないようにしてください。深刻な怪我や物的損害が生じるおそれがあります!
- 注意: 请勿超过列出的最大载重量, 否则可能会造成严重的伤害或财产损失!

DETAILS

DETAILS
DÉTAILS/POINTS DE MONTAGE
NOTE PARTICOLARI

DETALLES
組み立てのポイント
詳細情報

UNIT: INCH/CM/厘米

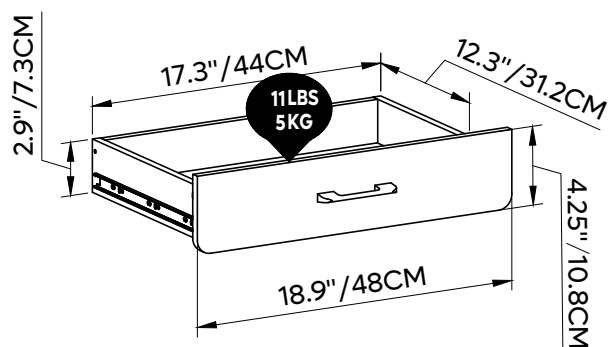
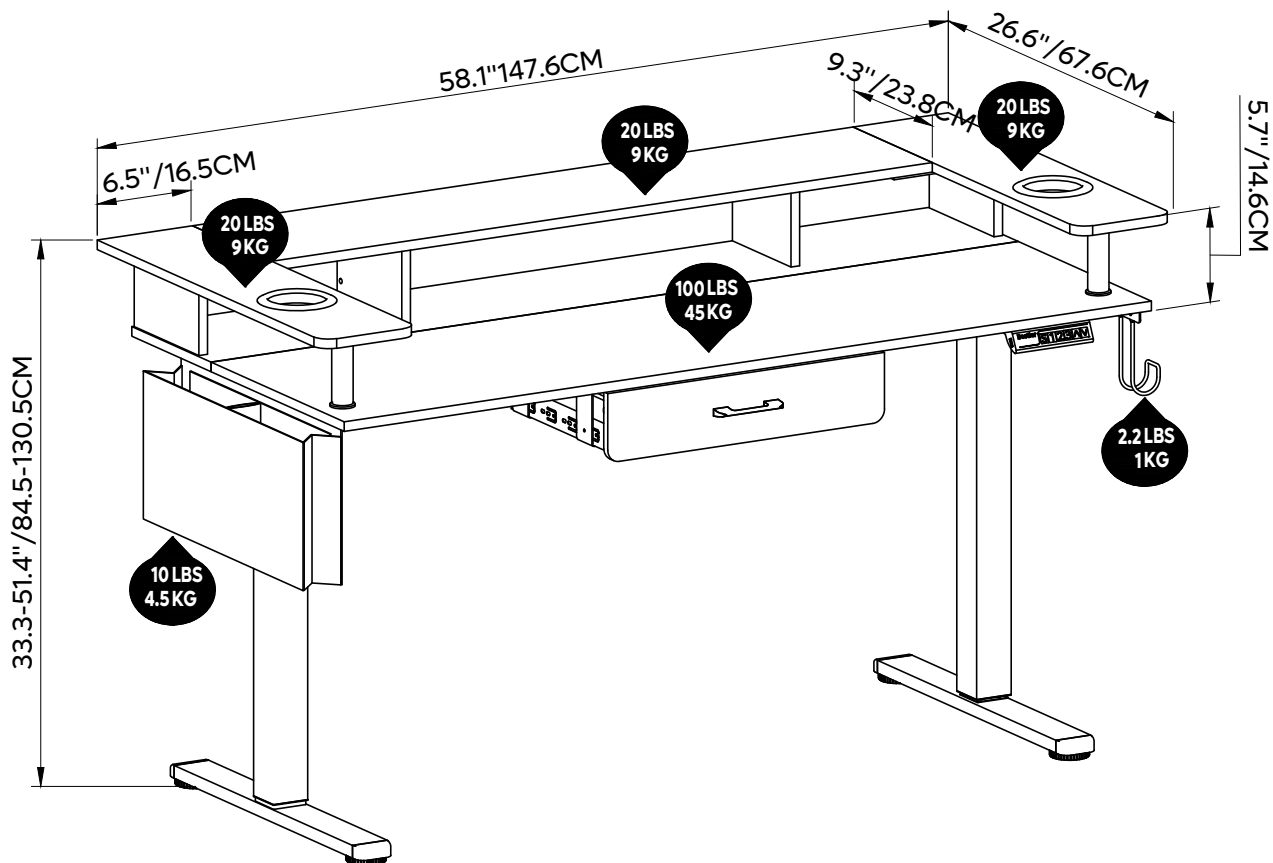

DETAILS

DETAILS
DÉTAILS/POINTS DE MONTAGE
NOTE PARTICOLARI



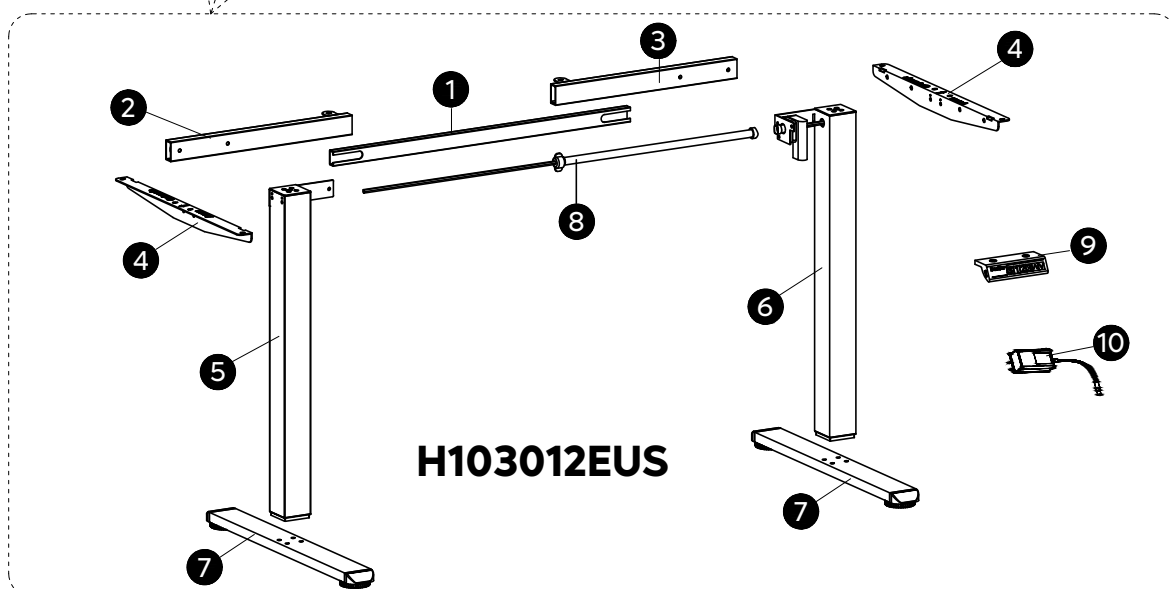
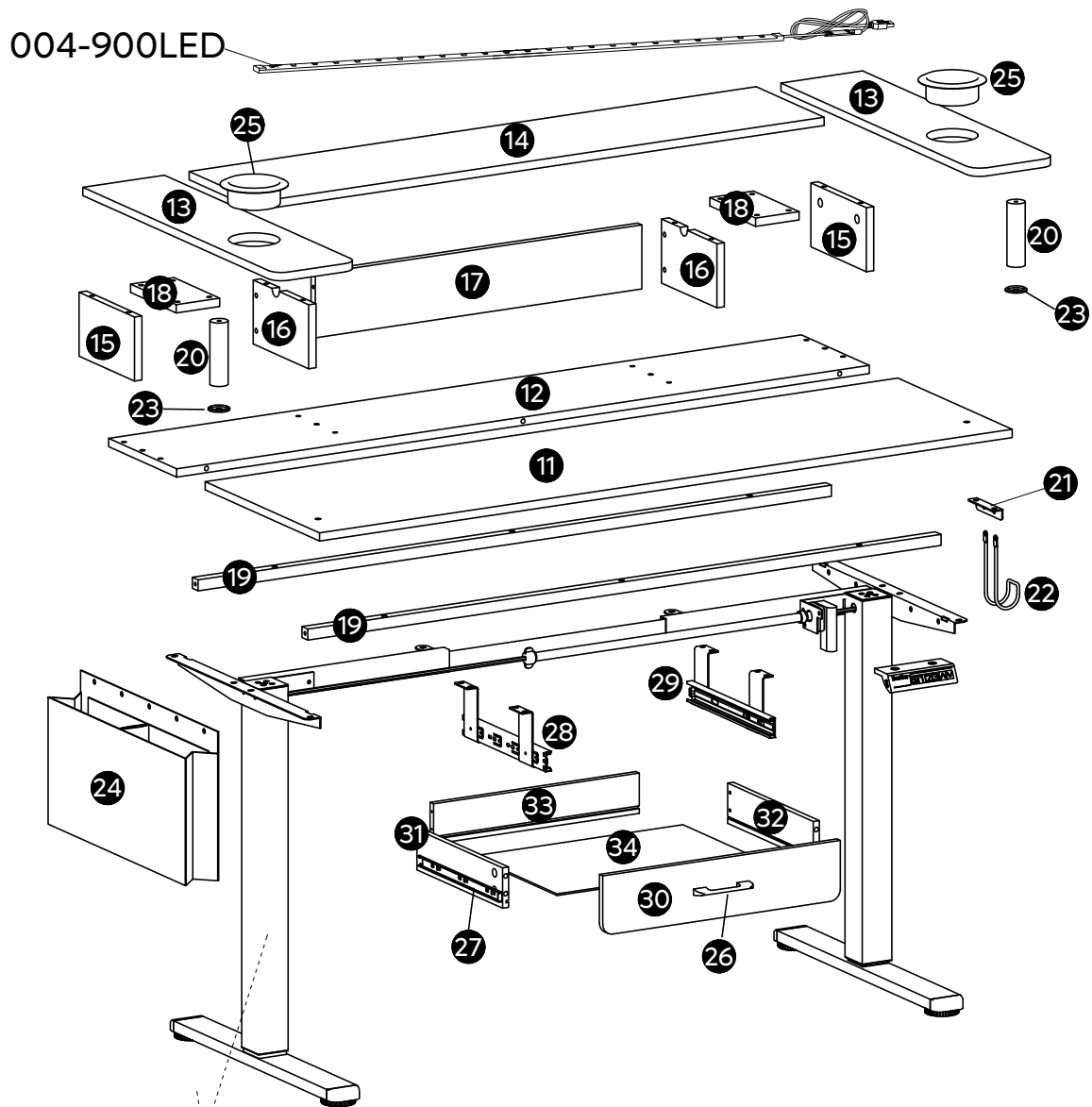









DETALLES
組み立てのポイント
詳細情報

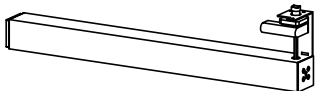
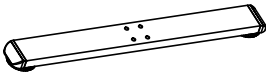

PART LIST

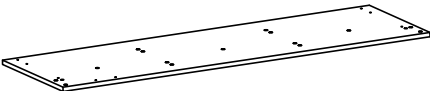
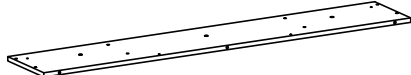
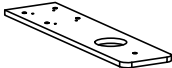
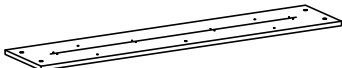
STÜCKLISTE
LISTE DES PIÈCES
ELENCO DEI PEZZI









LISTA DE PIEZAS
部品の確認
部件清單

<p>①</p>  <p>X1</p>	<p>②</p>  <p>X1</p>	<p>③</p>  <p>X1</p>
<p>④</p>  <p>X2</p>	<p>⑤</p>  <p>X1</p>	<p>⑥</p>  <p>X1</p>
<p>⑦</p>  <p>X2</p>	<p>⑧</p>  <p>X1</p>	<p>⑨</p>  <p>X1</p>
<p>⑩</p>  <p>X1</p>	<p>⑪</p>  <p>X1</p>	<p>⑫</p>  <p>X1</p>
<p>⑬</p>  <p>X2</p>	<p>⑭</p>  <p>X1</p>	<p>⑮</p>  <p>X2</p>
<p>⑯</p>  <p>X2</p>	<p>⑰</p>  <p>X1</p>	<p>⑱</p>  <p>X2</p>

PART LIST

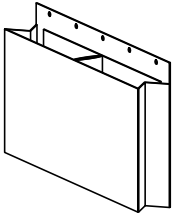
STÜCKLISTE
LISTE DES PIÈCES
ELENCO DEI PEZZI

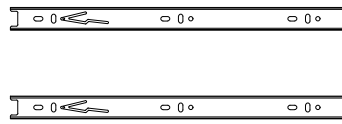
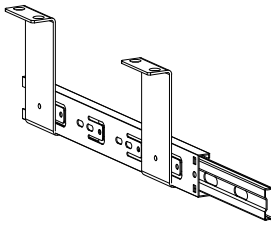
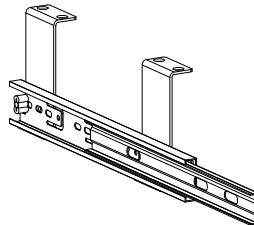
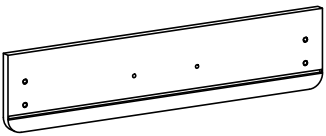
LISTA DE PIEZAS
部品の確認
部件清单

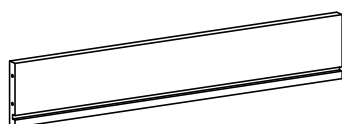
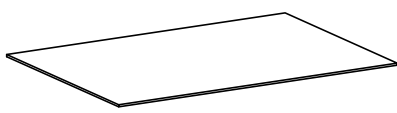
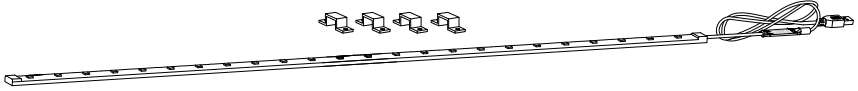
<p>19</p>  <p>X2</p>	<p>20</p>  <p>X2</p>	<p>21</p>  <p>X1</p>
<p>22</p>  <p>X1</p>	<p>23</p>  <p>X2</p>	<p>24</p>  <p>X1</p>
<p>25</p>  <p>X2</p>	<p>26</p>  <p>X1</p>	<p>27</p>  <p>1SET</p>
<p>28</p>  <p>X1</p>	<p>29</p>  <p>X1</p>	<p>30</p>  <p>X1</p>
<p>31</p>  <p>X1</p>	<p>32</p>  <p>X1</p>	<p>33</p>  <p>X1</p>
<p>34</p>  <p>X1</p>	<p>004-900LED</p>  <p>X1</p>	

PART LIST

STÜCKLISTE
LISTE DES PIÈCES
ELENCO DEI PEZZI

LISTA DE PIEZAS
部品の確認
部件清单

- Part #1~Part #10 are positioned in the packing box of the base.
- Les accessoires de la partie no 1 jusqu'à la partie no 10 sont rangés dans le carton d'emballage de la base.
- Teil #1~Teil #10 sind in der Verpackungsbox des Sockels untergebracht.
- Le parti da 1 a 10 si trovano nella scatola di imballaggio della base.
- Pieza #1~Pieza #10 se colocan en la caja de embalaje de la base.
- 部品#1~部品#10は、台座の梱包箱に入っています。
- Part #1~Part #10在基座的包装箱里。

※Please follow the instruction for installation and ignore the instruction in the packing box of the base.
※Veuillez suivre les consignes d'installation et ignorer les consignes qui sont dans le carton d'emballage de la base.
※Bitte befolgen Sie die Installationsanleitung und ignorieren Sie die Anleitung in der Verpackungsbox des Sockels.
※Installare secondo questo manuale di istruzioni e ignorare le istruzioni nella scatola di imballaggio di base.
※Siga las instrucciones de instalación e ignore las instrucciones de la caja de embalaje de la base.
※取り付けに関する指示に従い、台座の梱包箱にある指示は無視してください。
※请按照此说明书进行安装，忽略基座包装箱里的说明书。

ACCESSORY LIST

ZUBEHÖRLISTE
LISTE DES ACCESSOIRES
ELENCO DEGLI ACCESSORI





LISTA DE ACCESORIOS
付属品部品の確認
配件清單

Part 1

Partie 1
Teil 1

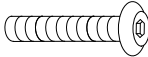
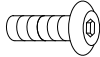
Parte 1
Parte 1

パート1
第一部分

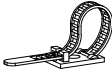

A	M6x35mm	8	
B	M6x11mm	12	
C	M5x16mm	12	
D		10	
E	S=2mm	1	
F	S=5mm	1	
G		4	

SPARE PARTS

Pièces détachées
Ersatzteile

Pezzi di ricambio
Piezas de recambio

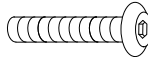
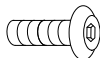
スペアパーツ
备件

A	M6x35mm	1	
B	M6x11mm	2	
C	M5x16mm	2	
D		2	

- The above hardware accessories are positioned in the packing box of the base.
- Les accessoires matériels ci-dessous sont rangés dans le carton d'emballage de la base.
- Die oben genannten Zubehörteile befinden sich in der Verpackungsbox des Sockels.
- Gli accessori hardware sopra indicati si trovano nella scatola di imballaggio della base.
- Los accesorios de hardware anteriores se colocan en la caja de embalaje de la base.
- 上記ハードウェアアクセサリは、台座の梱包箱に入っています。
- 以上五金配件在基座的包装箱里。

ACCESSORY LIST

ZUBEHÖRLISTE
LISTE DES ACCESSOIRES
ELENCO DEGLI ACCESSORI









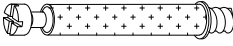

LISTA DE ACCESORIOS
付属品部品の確認
配件清單

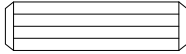
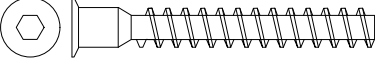
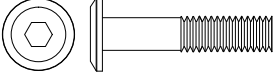
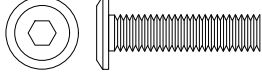
Part **2**

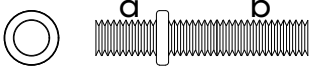
Partie 2
Teil 2

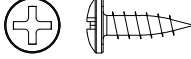
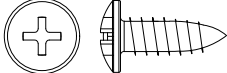
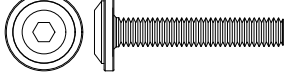
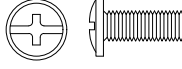
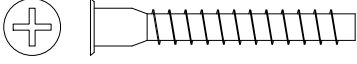
Parte 2
Parte 2

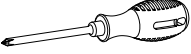
パート2
第二部分

H	ST6x35mm	12+1	
I	Ø15mm	12+1	
J	Ø8x30mm	7+2	
K	ST7x50mm	12+1	
L	M6x28mm	6+1	
M	M6x25mm	12+1	
N	M6x12mm	14+1	
O	M6x35mm	2	
P	M6mm	4+1	
Q	ST3.5x12mm	14+1	
R	ST5x14mm	12+1	
S	M6x35mm	2	
T	M4x16mm	2	
U	ST5x35mm	4+1	
	S=4mm	1	
		1	
		1	

Detailed Installation for Accessory H I

Installation détaillée pour l'accessoire H I
 Detaillierte Installation des Zubehörs H I
 Installazione dettagliata per l'accessorio H I
 Instalación detallada del accesorio H I
 カムロック取り付け方
 配件H、I详细安装

1

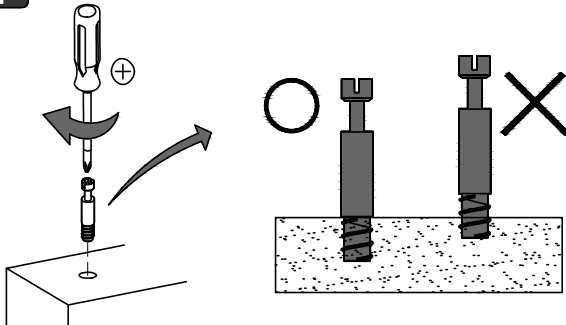

Screw cam dowel on the panel.
 Vissez la goupille de came au panneau.
 Nockendübel auf die Platte schrauben.
 Avvitare il tassello a camme sul pannello.
 tornillo de pasador de leva en el panel.
 カムロックネジを部品に取り付ける。
 螺杆用十字螺丝刀装入对应的预留孔内

Place another panel via the dowel.
 Placez un autre panneau par le goujon.
 Setzen Sie eine weitere Platte über den Dübel ein.
 Posizionare un altro pannello tramite il tassello.
 Coloque otro panel a través del pasador.
 カムロックネジをカムロック穴に差し込む。
 螺杆插入对应孔位，将两块板材对接起来。

2

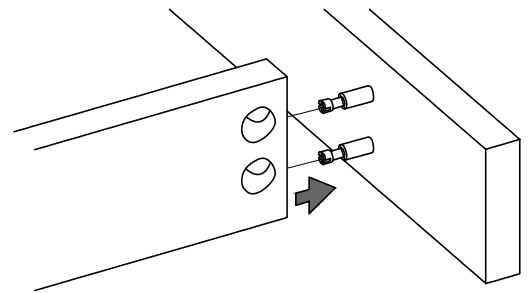

3

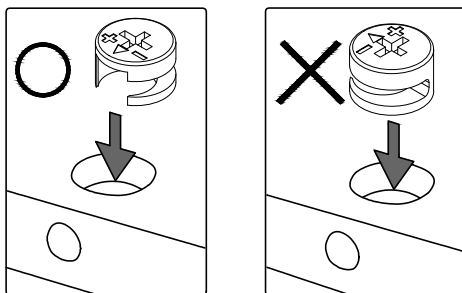

Pay attention to the direction of cam lock when putting it into hole.

Faites attention à la direction du verrou à came en entrant dans le trou.

Achten Sie auf die Richtung des Nockenschlosses, wenn Sie es in das Loch stecken.

Fare attenzione alla direzione della serratura a camme quando lo si inserisce nel foro.

Preste atención a la dirección de la leva de fijación al insertarla en el orificio.

カムロックネジの方向にカムロックの穴の穴の向きを合わせ取り付け。

装入锁扣圆盘，注意锁扣圆盘的方向；

Tighten up cam lock clockwise until it stops.
 Serrez le verrou à came dans le sens des aiguilles d'une montre jusqu'à ce qu'il s'arrête.
 Ziehen Sie die Nockenverriegelung im Uhrzeigersinn bis zum Anschlag an.
 Stringere la serratura a camme in senso orario fino all'arresto.
 Apriete la leva de fijación en sentido horario hasta el tope.
 カムロックをドライバーで締め固定する。
 顺时针旋转锁扣圆盘并锁紧。

4

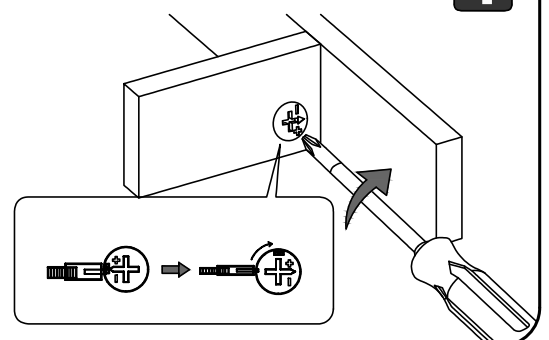

Detailed Installation for LED Strip

Installation détaillée de la bande LED
 Ausführliche Anbringungsanleitung für LED-Streifen
 Installazione dettagliata della striscia LED
 Instalación detallada de la tira de LED
 LEDストリップライトの設置に関する詳細説明
 LED 灯带安装方法

- 1**
- Remove about 25mm (1") of adhesive tape at both ends of LED light strip.
 - Retirez environ 25 mm de ruban adhésif à chaque extrémité de la bande lumineuse LED.
 - An beiden Enden des LED-Streifens etwa 25 mm (1 Zoll) des Klebebandes entfernen.
 - Rimuovere circa 25 mm di nastro adesivo su entrambe le estremità della striscia luminosa a LED.
 - Retire unos 25 mm (1") de la cinta adhesiva en ambos extremos de la tira de luces LED.
 - LEDストリップライトの両端にある粘着テープを約25mm (1") はがしてください。
 - 揭开LED灯带两端的胶纸约25mm (1")。

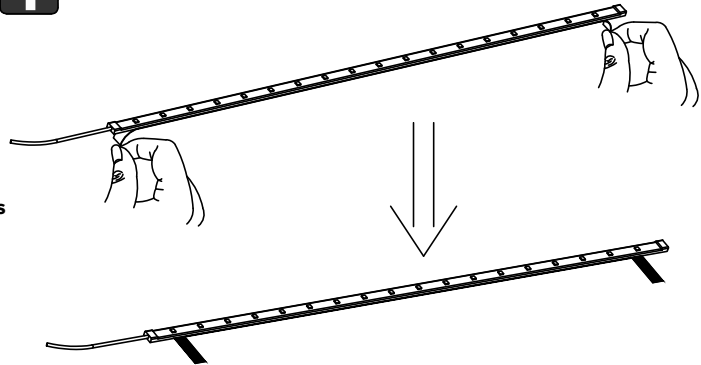

- 2**
- The head and tail of the LED light strip are pasted in a straight line, and the fixing parts at both ends are locked with screws.
 - Tête et queue du ruban LED collé sur une ligne droite, et les pièces de fixation situées à chaque extrémité sont sécurisées par des vis.
 - Kopf und Heck des LED-Lichtstreifens sind in einer geraden Linie geklebt und die Befestigungselemente anschrauben.
 - La testa e la coda della striscia luminosa LED sono incollati in un dritto Linea, e le parti di fissaggio ad entrambe le estremità sono bloccate con viti.
 - La cabeza y la cola del cinturón de Luz LED se pegan en línea recta Cable, las piezas de fijación en ambos extremos están cerradas con tornillos.
 - LEDライトバンドの頭部と尾部を直線に貼り付けるワイヤ、両端の固定具はネジでロックします。
 - LED灯带头尾沿着直线粘贴,用螺丝将两端的固定件锁住。

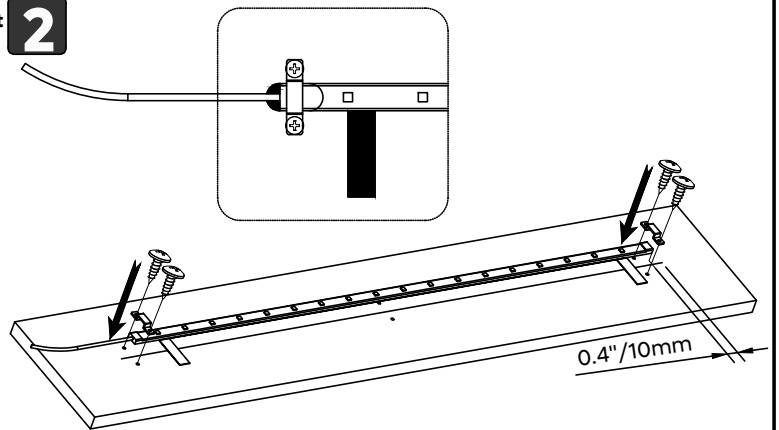

- 3**
- Tear off the whole protective paper, and flatten the strip light so that the LED light strip is completely adhered to the wood.
 - Arrachez tout le papier de protection et aplatissez la bande lumineuse de manière à ce que la bande lumineuse à DEL soit complètement collée au bois.
 - Die gesamte Schutzfolie abziehen und den LED-Streifen so flach andrücken, dass er vollständig auf dem Holz aufliegt.
 - Strappare l'intera carta protettiva e appiattire la striscia luminosa in modo da farla aderire completamente al legno.
 - Retire todo el papel protector y aplane la tira de luz para que la tira de luz LED quede completamente adherida a la madera.
 - 全体の保護ペーパーをはがしてLEDストリップライトを平らにして、木材に完全に貼り付けるようにします。
 - 将整条保护纸撕掉,并压平整条灯带,使LED灯带完全粘在木板上。

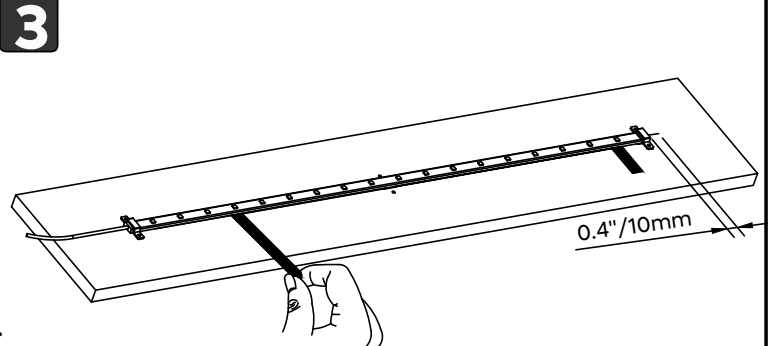

- 4**
- Lock the remaining fixings.
 - Verrouillez les autres fixations.
 - Die restlichen Befestigungen anziehen.
 - Bloccare i restanti elementi di fissaggio.
 - Bloquee las fijaciones restantes.
 - 残りの固定具を留めます。
 - 锁上剩下的固定件。

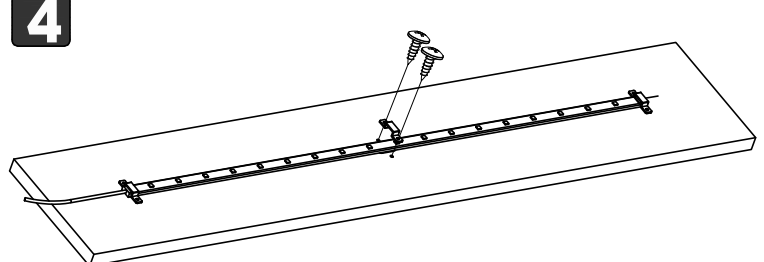

1

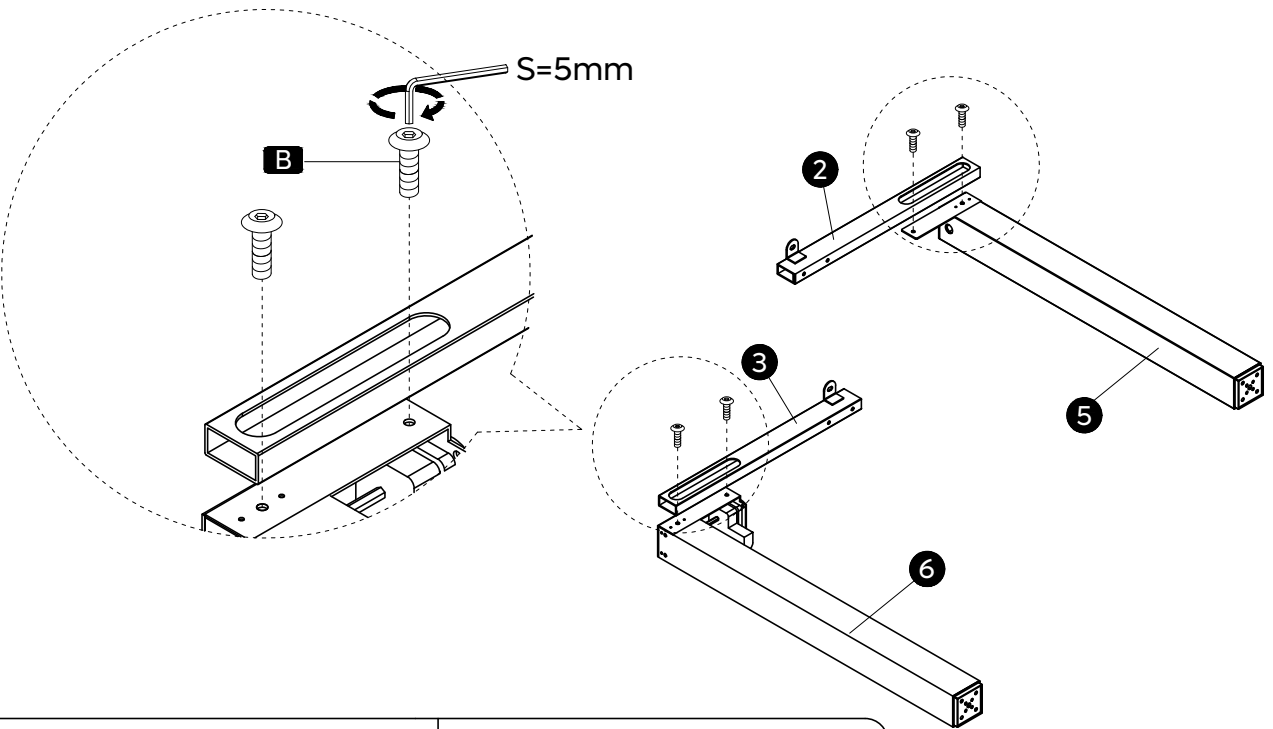

B

M6x11mm(x4)

F

S=5mm

2

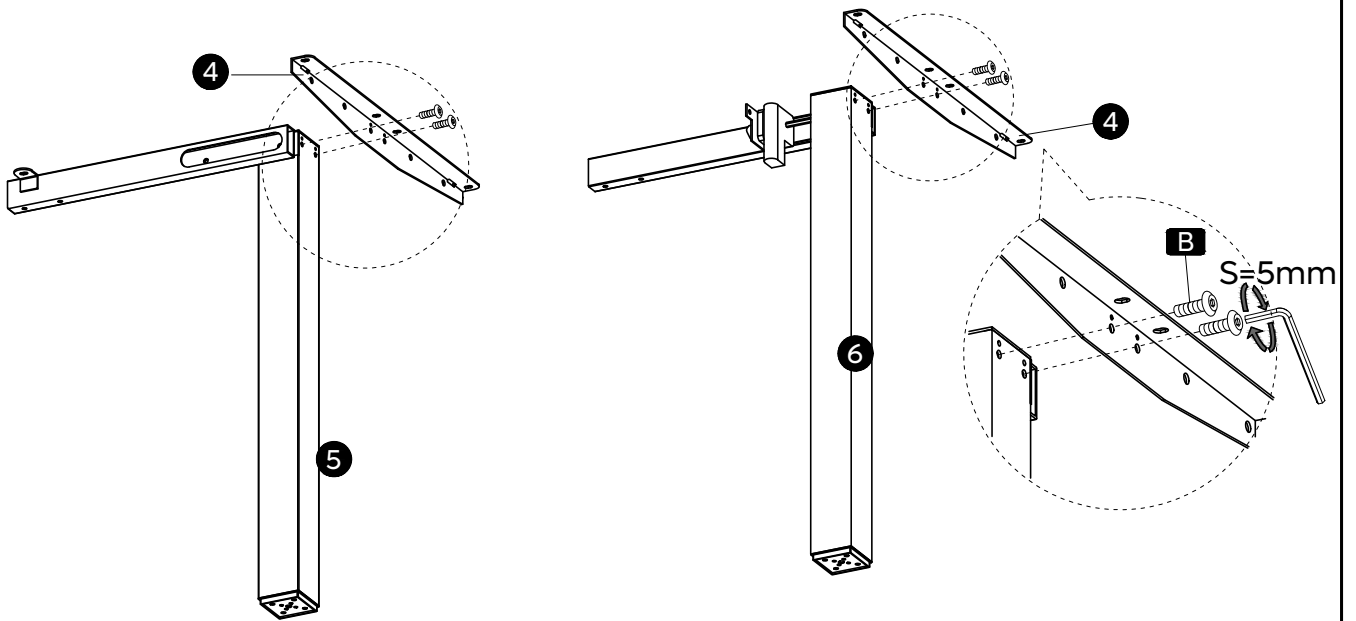

B

M6x11mm(x4)

F

S=5mm

3

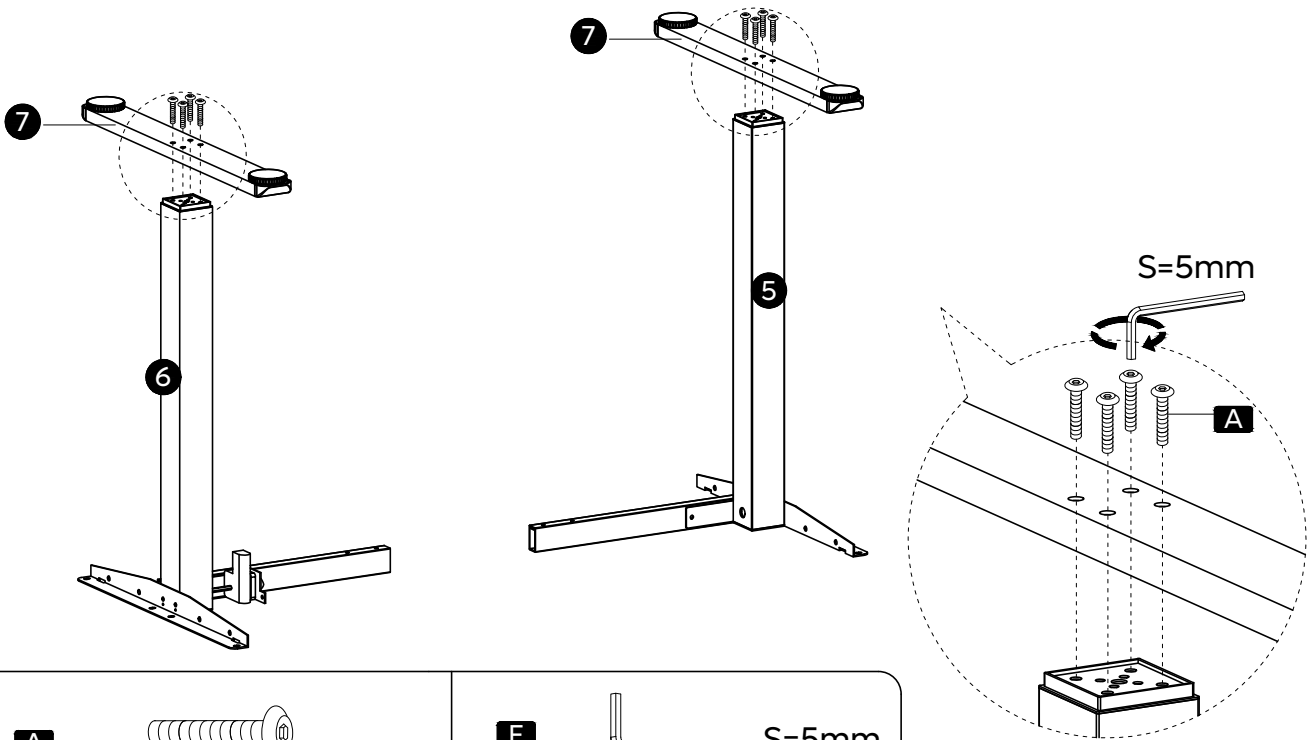

A

M6x35mm(x8)

F

S=5mm

4

80%
 80% tighten
 80 % serré
 80% festziehen
 Serraggio al 80%
 80 % reforzado
 80%締め付け
 80%锁紧

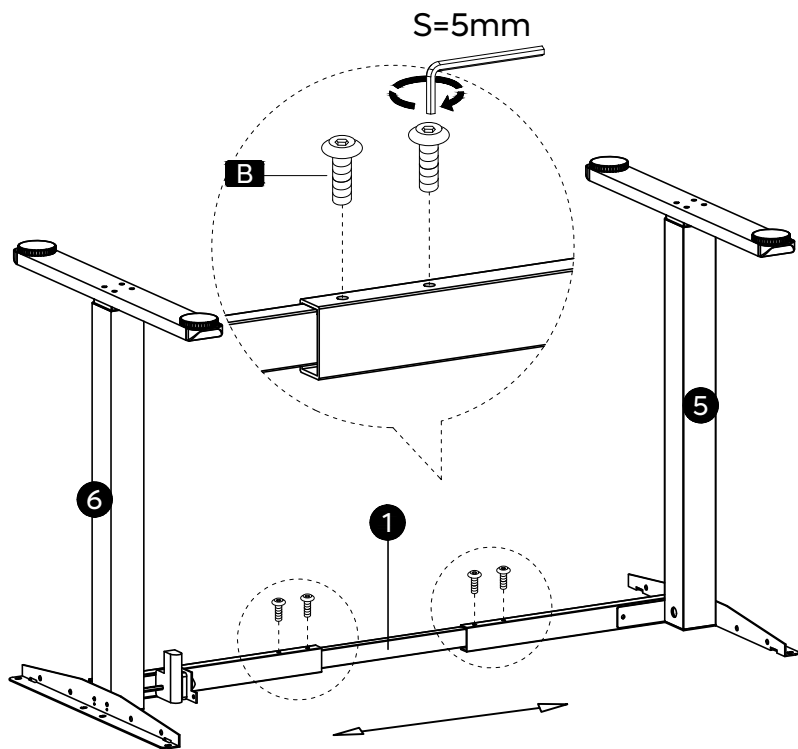

B

M6x11mm(x4)

F

S=5mm

5

80% tighten
 80 % serré
 80% festziehen
 Serraggio al 80%
 80 % reforzado
 80%締め付け
 80%锁紧

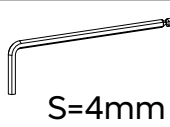
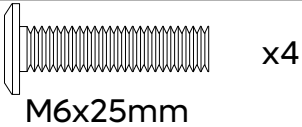
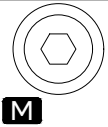
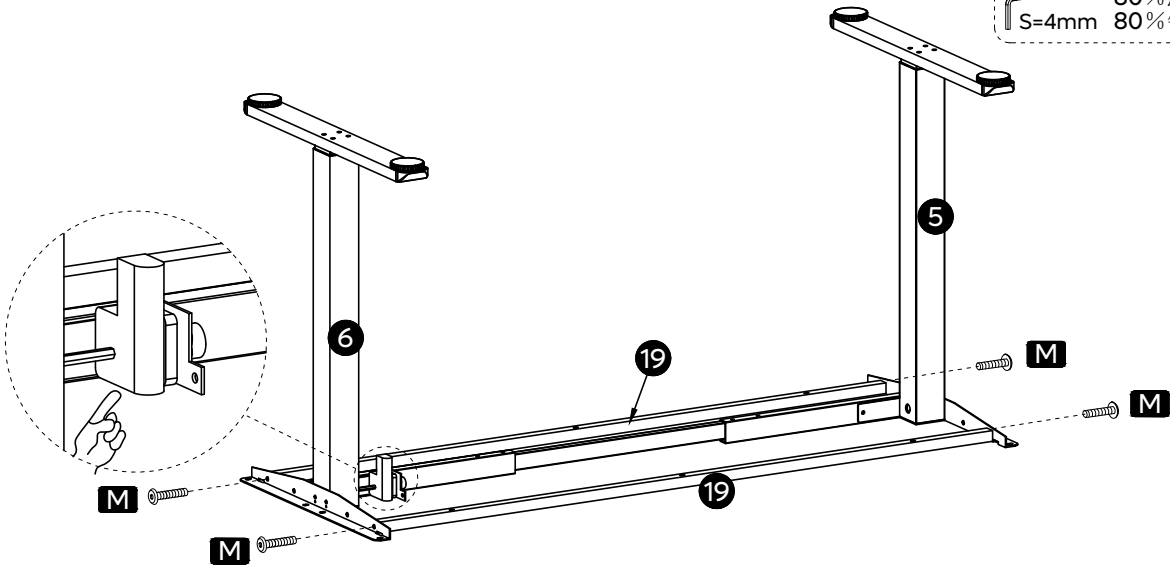
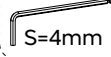

6

- ※ Two persons are needed.
- ※ Deux personnes sont nécessaires.
- ※ Zwei Personen sind erforderlich.
- ※ Sono necessarie due persone.
- ※ Se necesitan dos personas.
- ※ 必ず2人で作業してください。
- ※ 需要另外1个人协助。

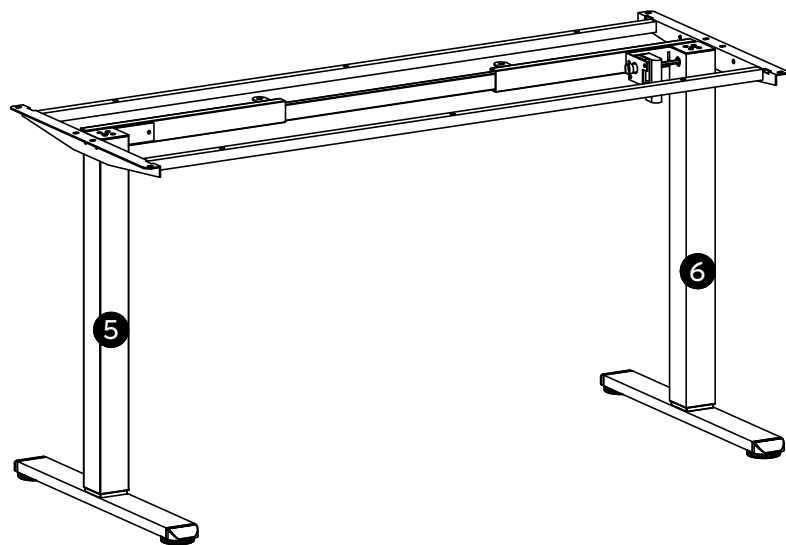
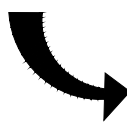
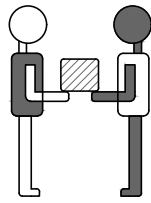

7

E

S=2mm

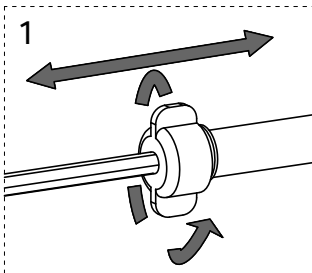
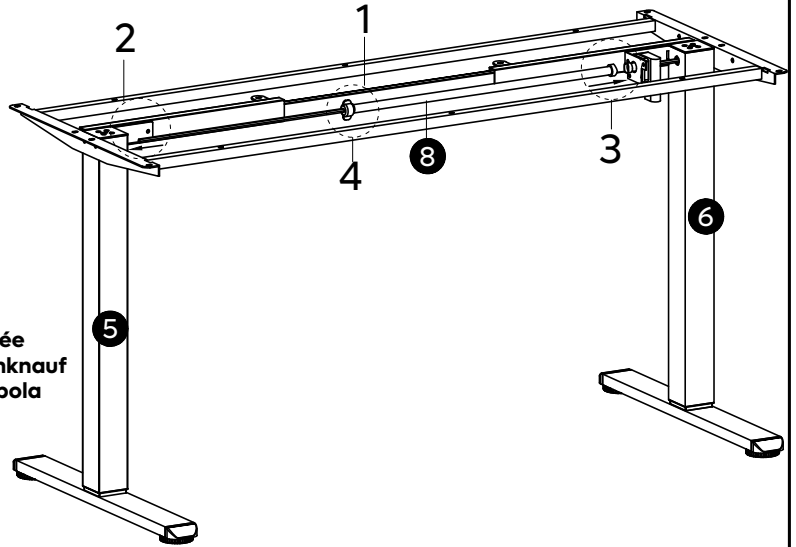

- Loosen the knob
- Desserrez la poignée
- Lösen Sie den Drehknopf
- Allentare la manopola
- Aflojar la perilla
- ノブを緩めます
- 拧松旋钮

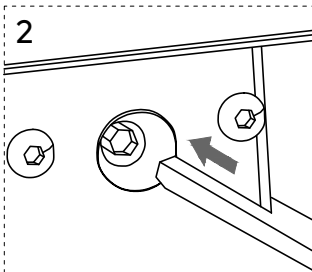

- Insert the transmission rod into the hex hole and turn the transmission rod clockwise until the left leg goes to the lowest position.
- Insérez la tige de transmission dans le trou hexagonal et tournez la tige de transmission dans le sens des aiguilles d'une montre jusqu'à ce que la jambe gauche atteigne la position la plus basse.
- Stecken Sie die Übertragungsstange in die Sechskantbohrung ein und drehen Sie die Übertragungsstange im Uhrzeigersinn, bis das linke Bein in die unterste Position einrastet.
- Inserire la barra di trasmissione nel foro esagonale e ruotare la barra di trasmissione in senso orario fin quando la gamba sinistra non raggiunge la posizione più bassa.
- Introducir la varilla de transmisión en el orificio con forma hexagonal y girar en el sentido de las agujas del reloj hasta que la pata izquierda esté en la posición más baja.
- 六角穴に伝達ロッドを挿入し、左脚が一番低い位置になるまで、伝達ロッドを時計回りに回します。
- 将传动杆插入六角孔中，顺时针转动传动杆直至左支脚到达最低位置。

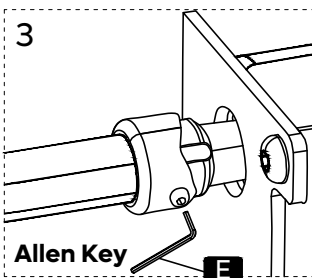

- Insert the other end of transmission rod to the slot on the leg (You may rotate the rod slightly for better installation). Secure the transmission rod to the slot by tightening the pre-assembled set screw using the small Allen key.
- aiguilles d'une montre jusqu'à ce que la jambe gauche atteigne la position la plus basse. Insérez l'autre extrémité de la tige de transmission dans la fente de la jambe (vous pourriez tourner légèrement la tige pour une meilleure installation). Fixez la tige de transmission à la fente en serrant la vis de blocage pré-montée à l'aide de la petite clé Allen.
- Führen Sie das andere Ende der Übertragungsstange in den Schlitz am Bein ein (Sie können die Stange für eine bessere Installation leicht drehen). Sichern Sie die Übertragungsstange im Schlitz, indem Sie die vormontierte Feststellschraube mit dem kleinen Inbusschlüssel anziehen.
- Inserire l'altra estremità della barra di trasmissione nella fessura sulla gamba (è possibile ruotare leggermente la barra per facilitare il montaggio). Fissare la barra di trasmissione alla fessura serrando la vite di arresto preinserita con la piccola chiave a brugola.
- Introducir el otro extremo de la varilla de transmisión en la ranura de la pata (hay que girar la varilla ligeramente para que se instale mejor). Fijar la varilla de transmisión en la ranura de la pata apretando el conjunto de tornillos premontados con una nave Allen pequeña.
- 伝達ロッドのもう一方の端を足の溝に挿入します（ロッドを少し回転させると取り付けやすくなります）。小さい六角レンチを使って、あらかじめ組み立てられた止めネジを締めることで、伝達ロッドを溝に固定します。
- 将传动杆的另一端插入支脚上的插槽内（为了确保安装更紧固，您可以稍微转动传动杆），用小型内六角扳手拧紧预先安装好的固定螺丝，将传动杆固定在插槽内。

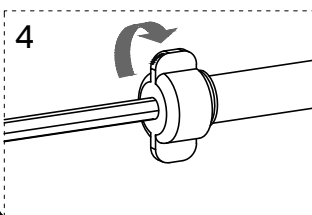

- Tighten the knob
- Serrer la poignée
- Ziehen Sie den Drehknopf
- Serrare la manopola
- Apriete la perilla
- ノブを締めます
- 拧紧旋钮

H1024147BUS

8

- Please refer to "Detailed Installation for LED Strip" on page "12".
- Veuillez consulter "Installation détaillée de la bande LED" sur la page "12".
- Siehe Seite "12" der "Ausführlichen Anbringungsanleitung für LED-Streifen".
- Fare riferimento a "Installazione dettagliata della striscia LED" a pagina "12".
- Consulte "Instalación detallada de la tira de LED" en la página "12".
- "12"ページにある"LEDストリップライトの設置に関する詳細説明"を参照してください。
- 请参考第 "12" 页 "LED 灯带安装方法"

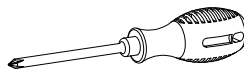
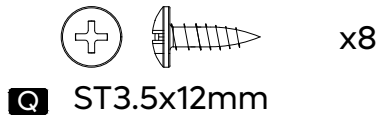
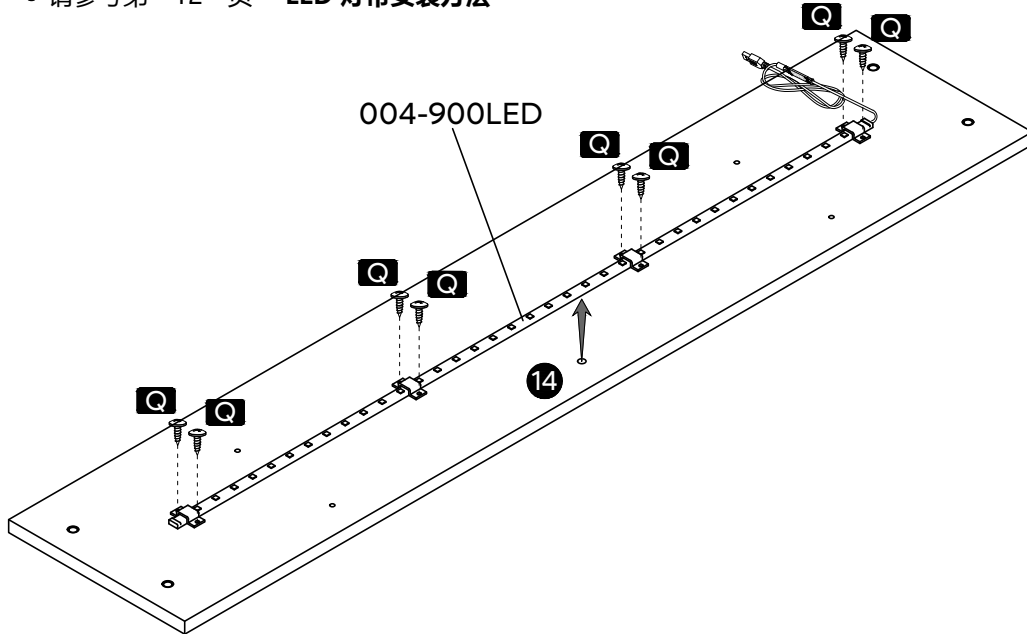

9

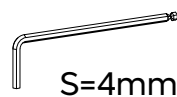
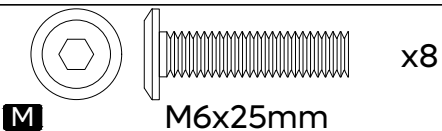
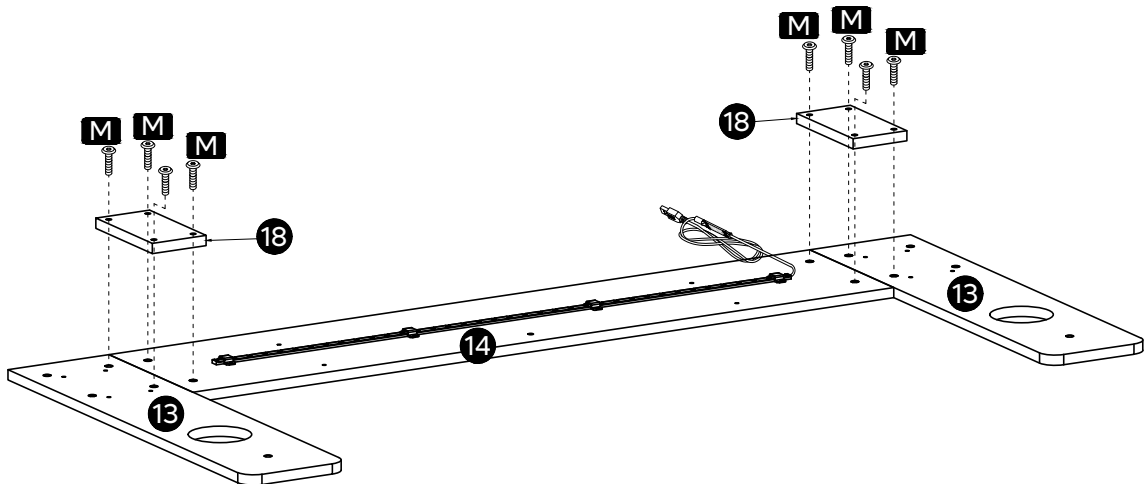

10

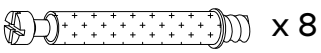
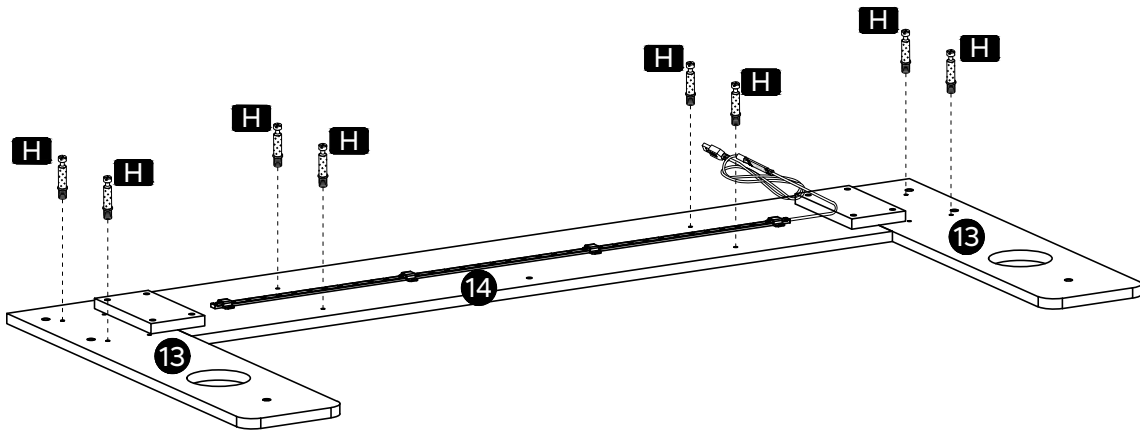

H ST6x35mm

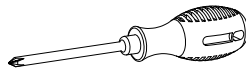

11

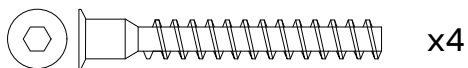
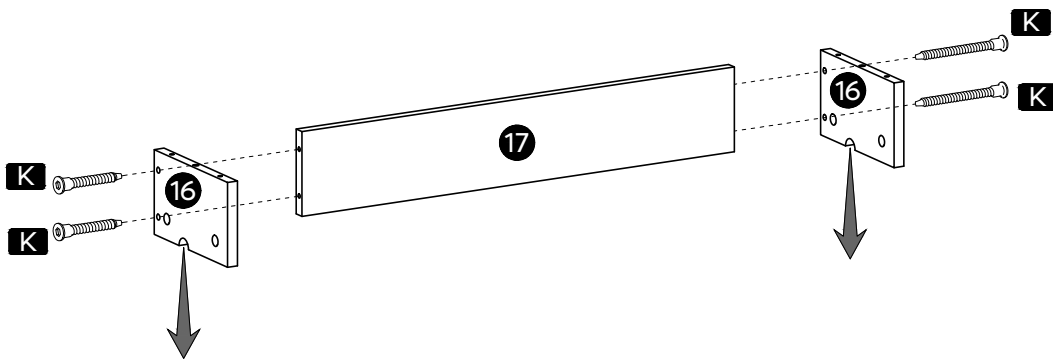

K ST7x50mm



S=4mm

H1024147BUS

12

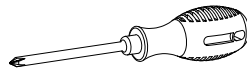
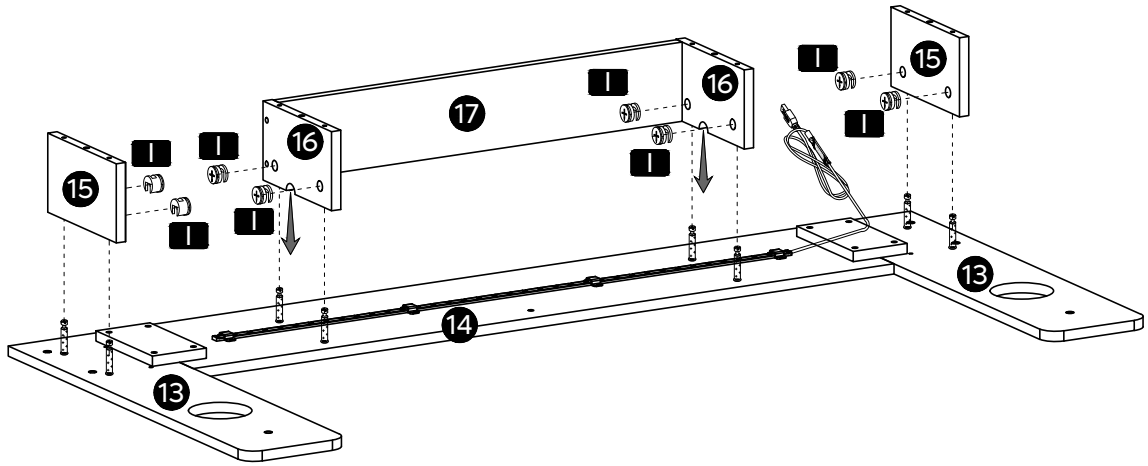

13

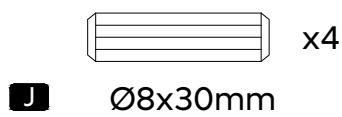
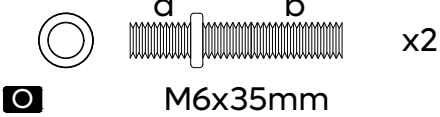
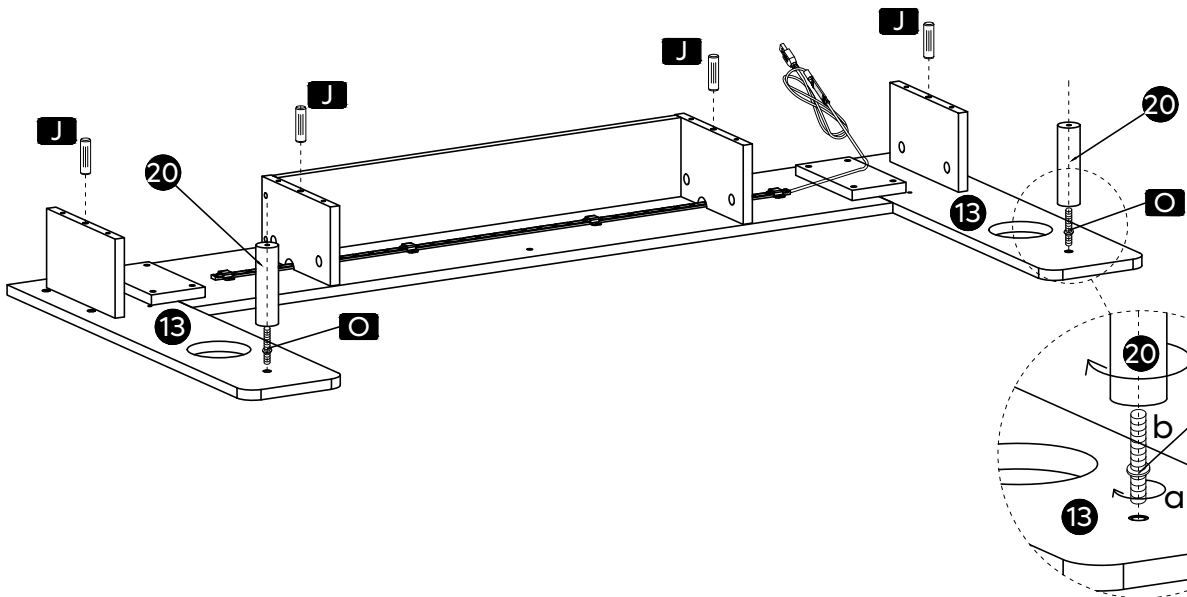

14

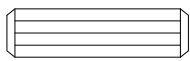
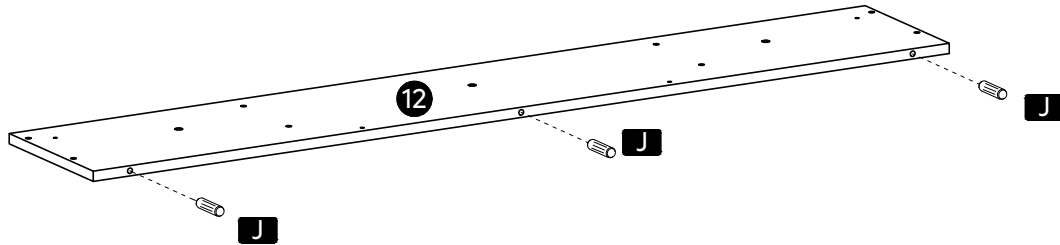

x3

J Ø8x30mm

15

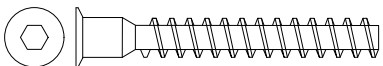
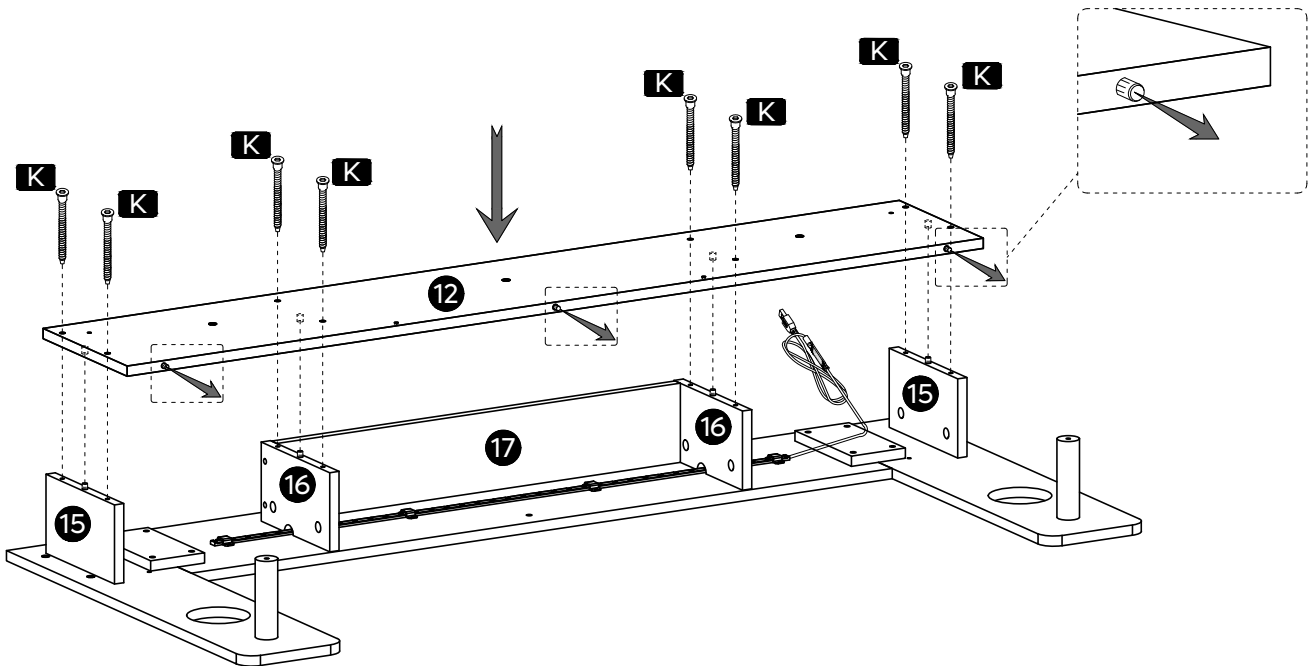

x8

K ST7x50mm

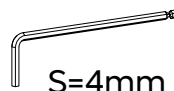

S=4mm

H1024147BUS

16

- ※ Two persons are needed.
- ※ Deux personnes sont nécessaires.
- ※ Zwei Personen sind erforderlich.
- ※ Sono necessarie due persone.
- ※ Se necesitan dos personas.
- ※ 必ず2人で作業してください。
- ※ 需要另外1个人协助。

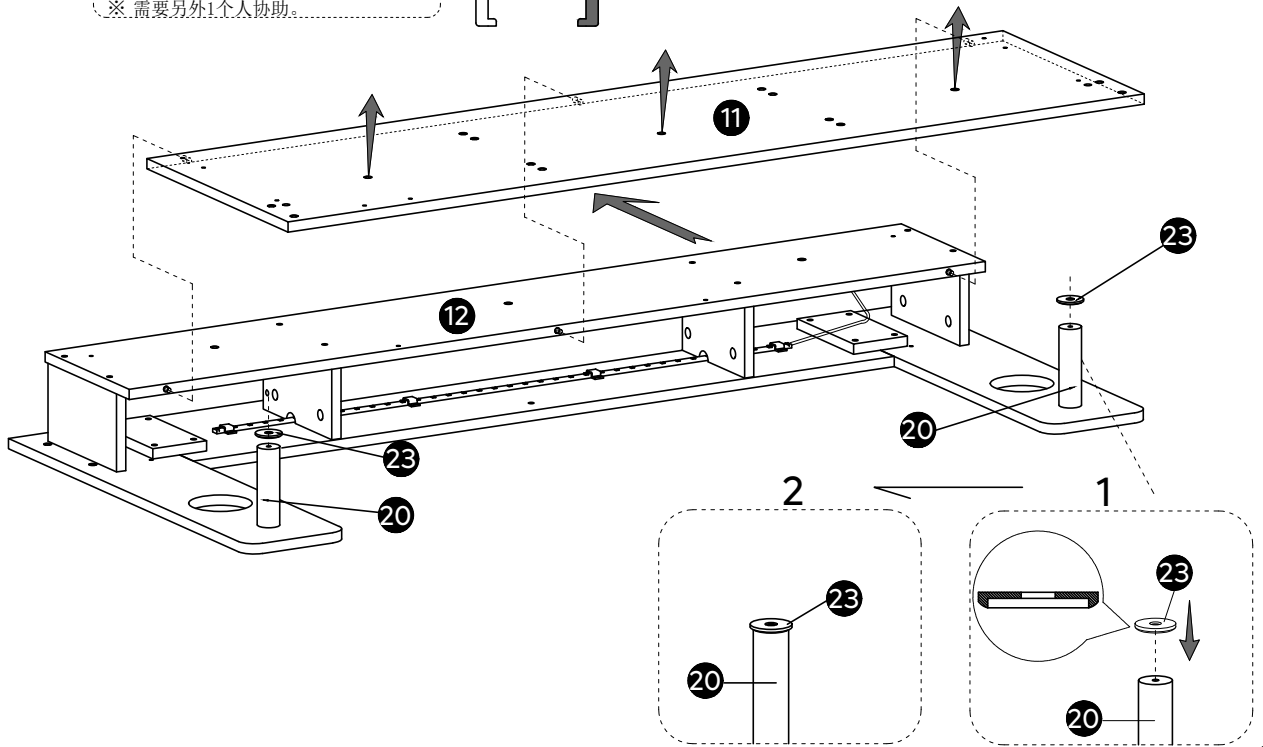
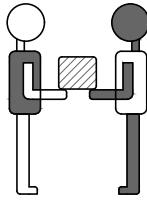

17

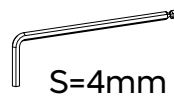
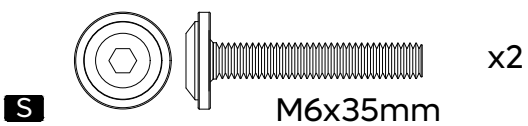
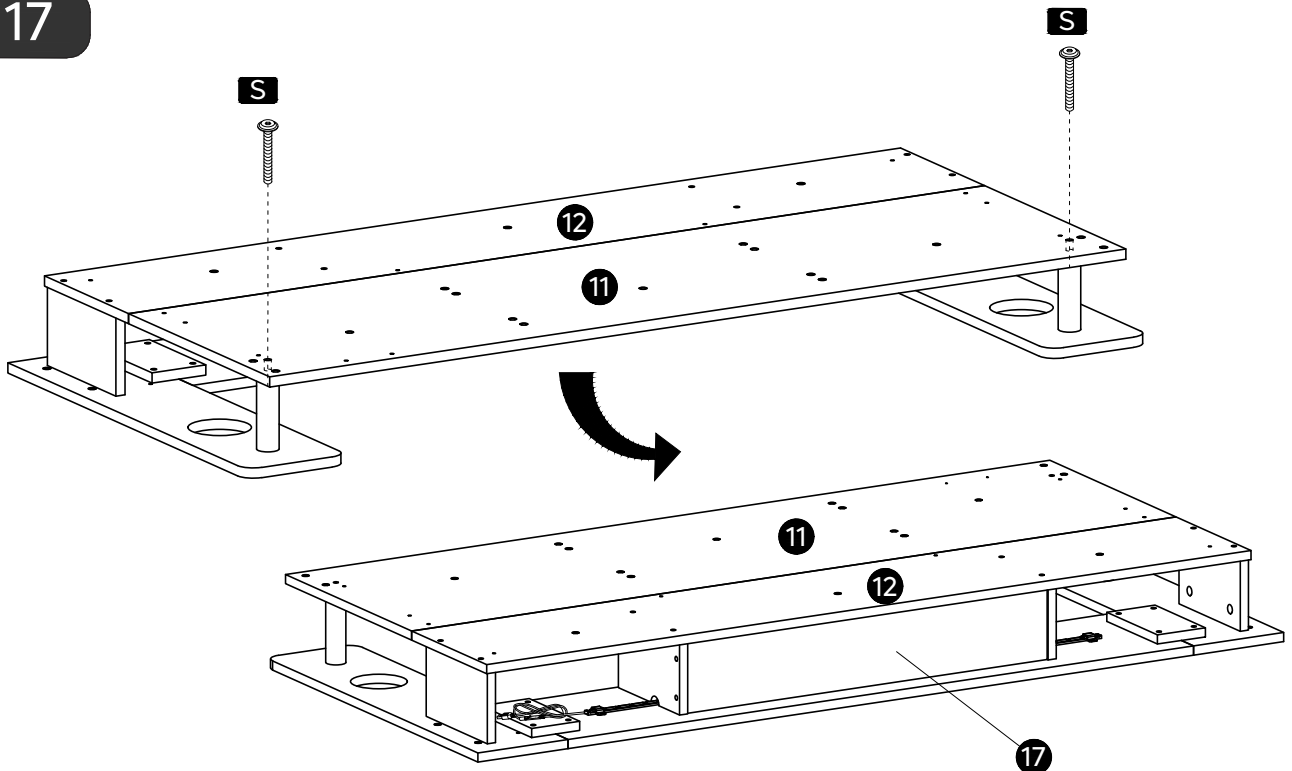

18

80% tighten
 80 % serré
 80% festziehen
 Serraggio al 80%
 80 % reforzado
 80%締め付け
 80%锁紧

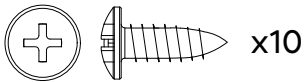
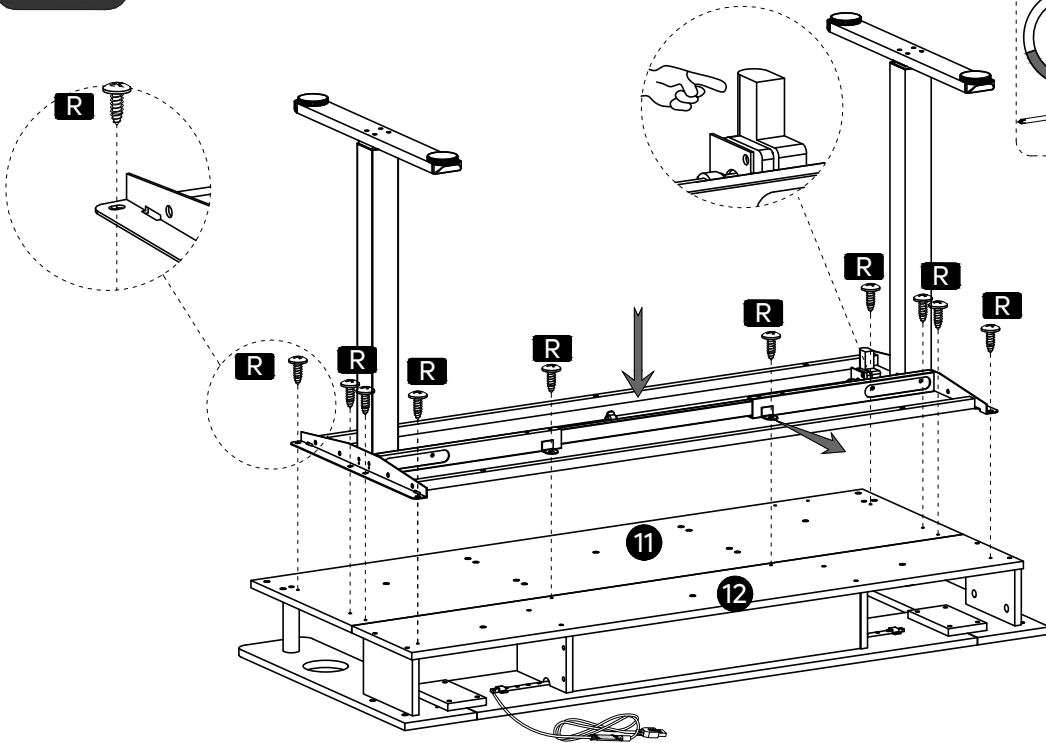

R ST5x14mm

x10

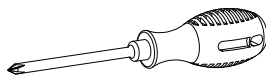

19

100% tighten
 100 % serré
 100% festziehen
 Serraggio al 100%
 100 % reforzado
 100%締め付け
 100%锁紧

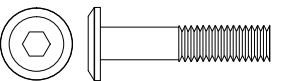
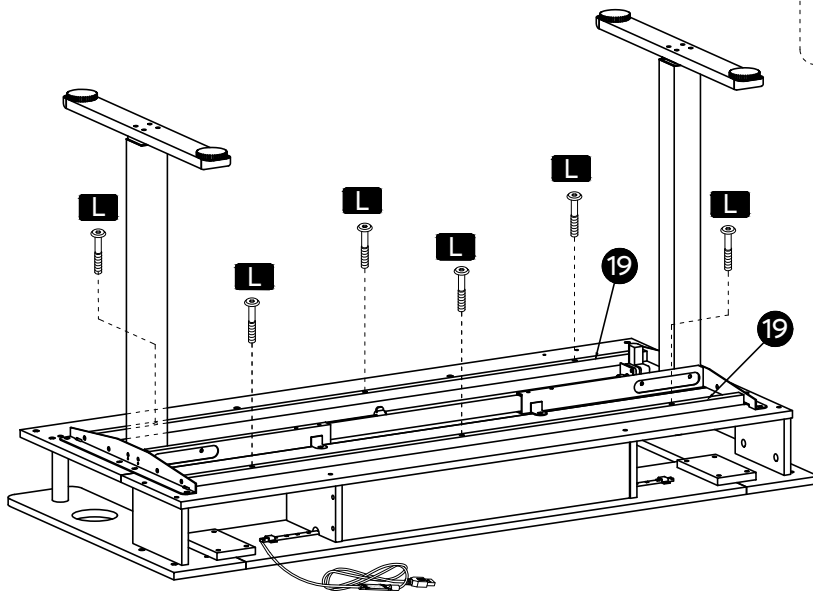

L M6x28mm

x6



S=4mm

H1024147BUS

20

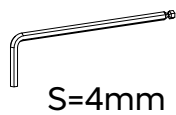
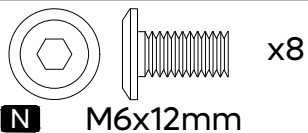
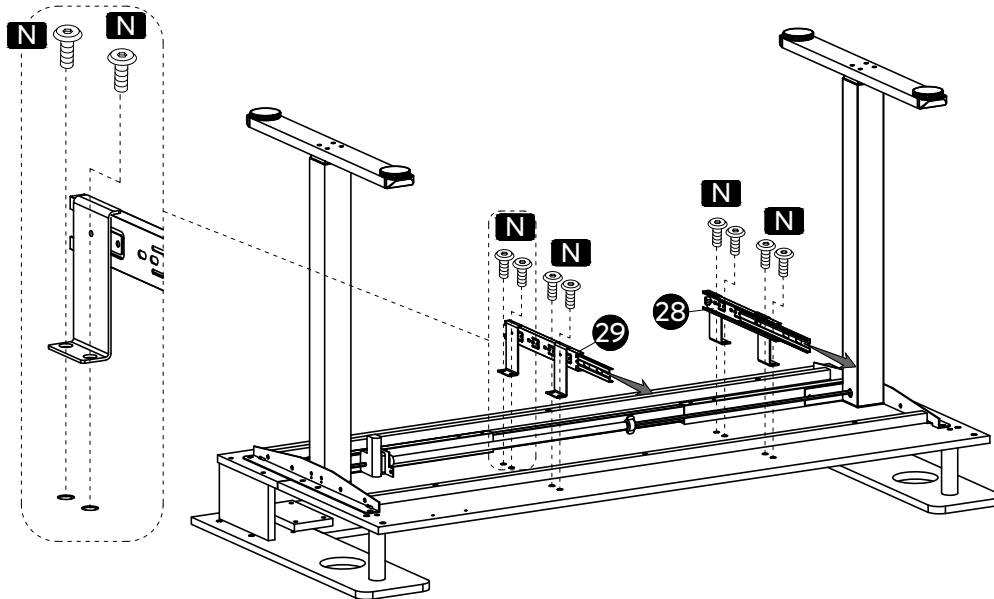

21

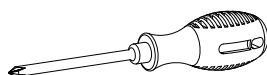
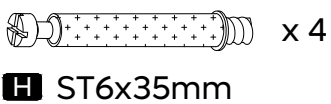
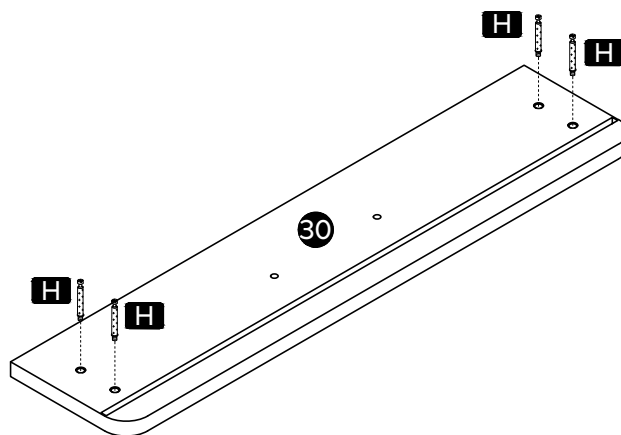

22

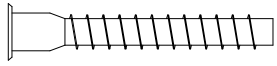
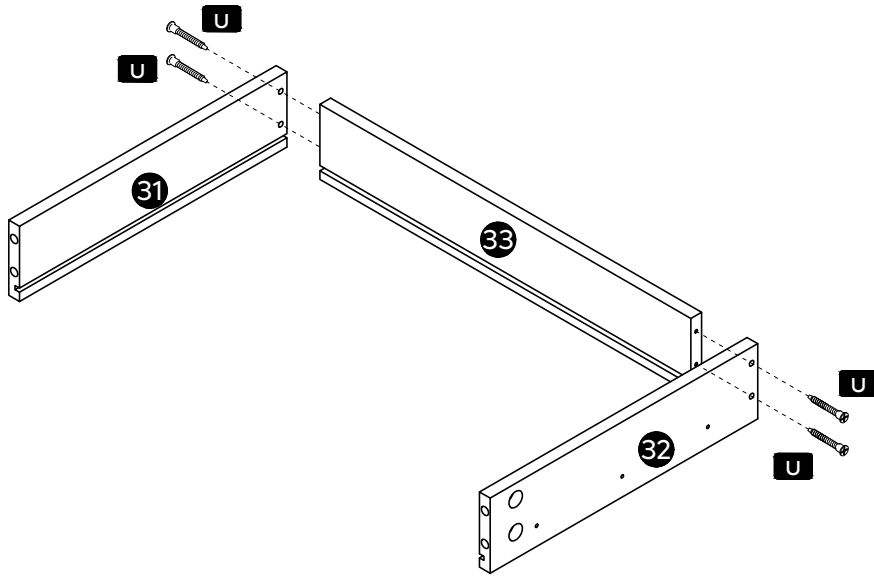

x 4

U ST5x35mm

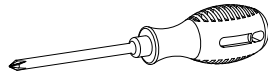

23

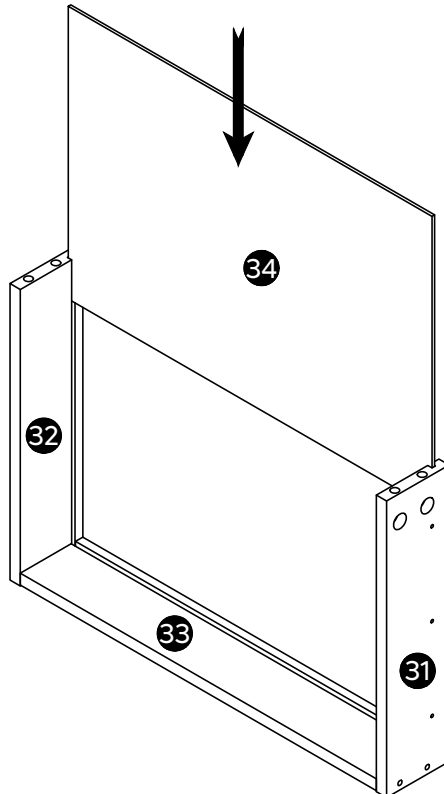

24

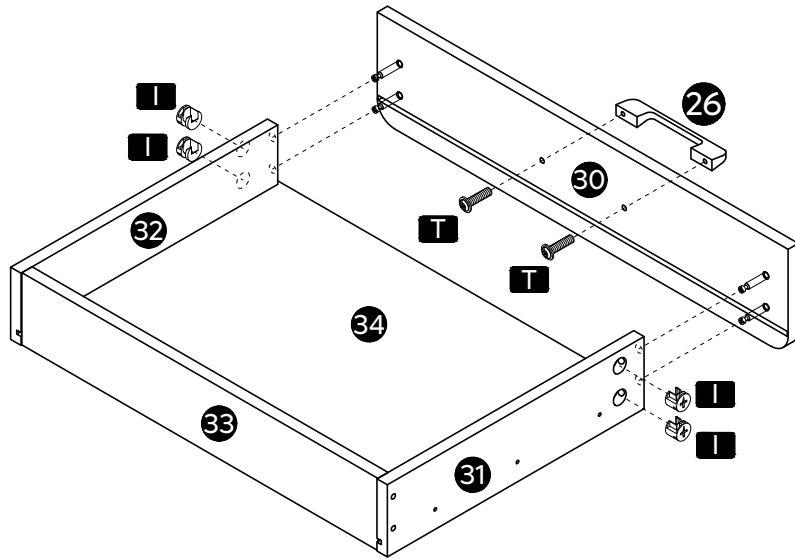

x 4

I Ø15mm



x 2

T M4x16mm

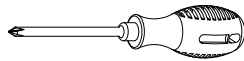

25

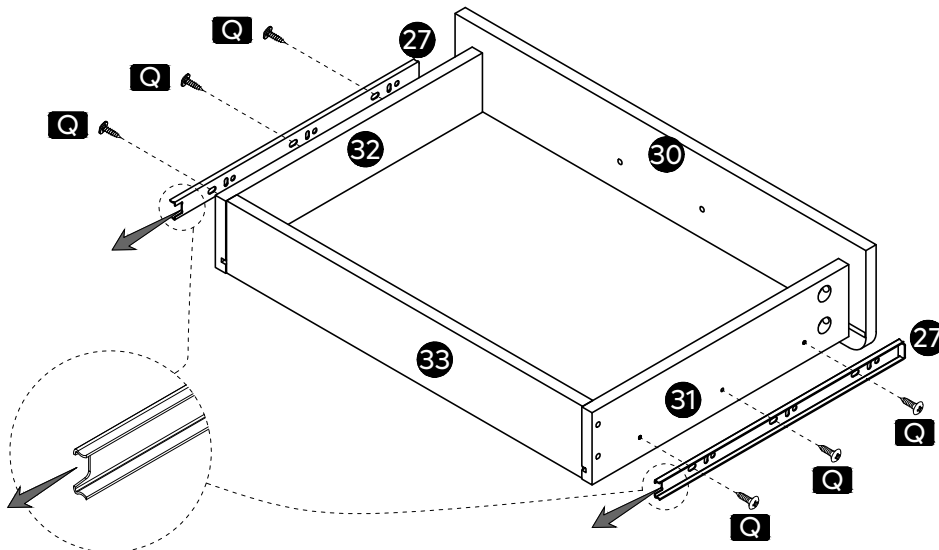

x 8

Q ST3.5x12mm

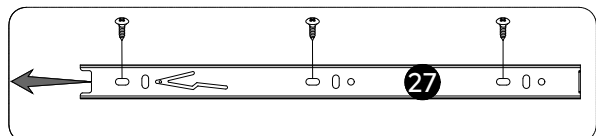
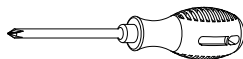

A

Style A: Step 1-25, 26-31
Style A : Étape 1-25, 26-31
Ausführung A: Schritt 1-25, 26-31
Stile A: Step 1-25, 26-31
Estilo A: paso 1-25, 26-31
スタイルA: ステップ 1-25, 26-31
安装方式A: 步骤1-25, 26-31

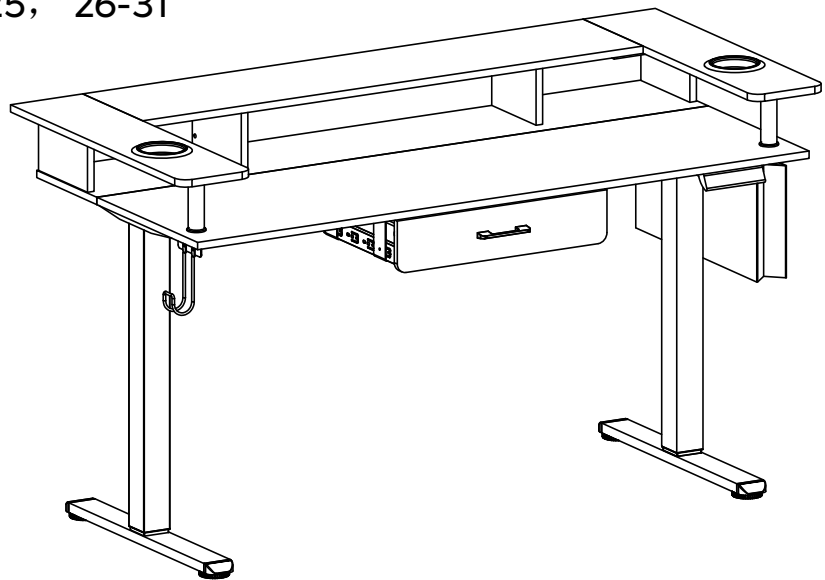

B

Style B: Step 1-25, 32-37
Style B : Étape 1-25, 32-37
Ausführung B: Schritt 1-25, 32-37
Stile B: Step 1-25, 32-37
Estilo B: paso 1-25, 32-37
スタイルB: ステップ 1-25, 32-37
安装方式B: 步骤1-25, 32-37

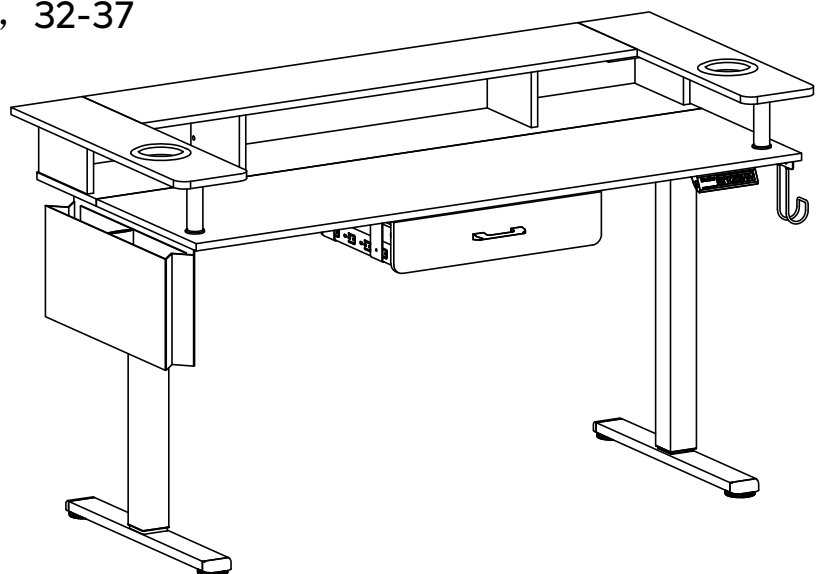

26

A

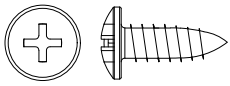
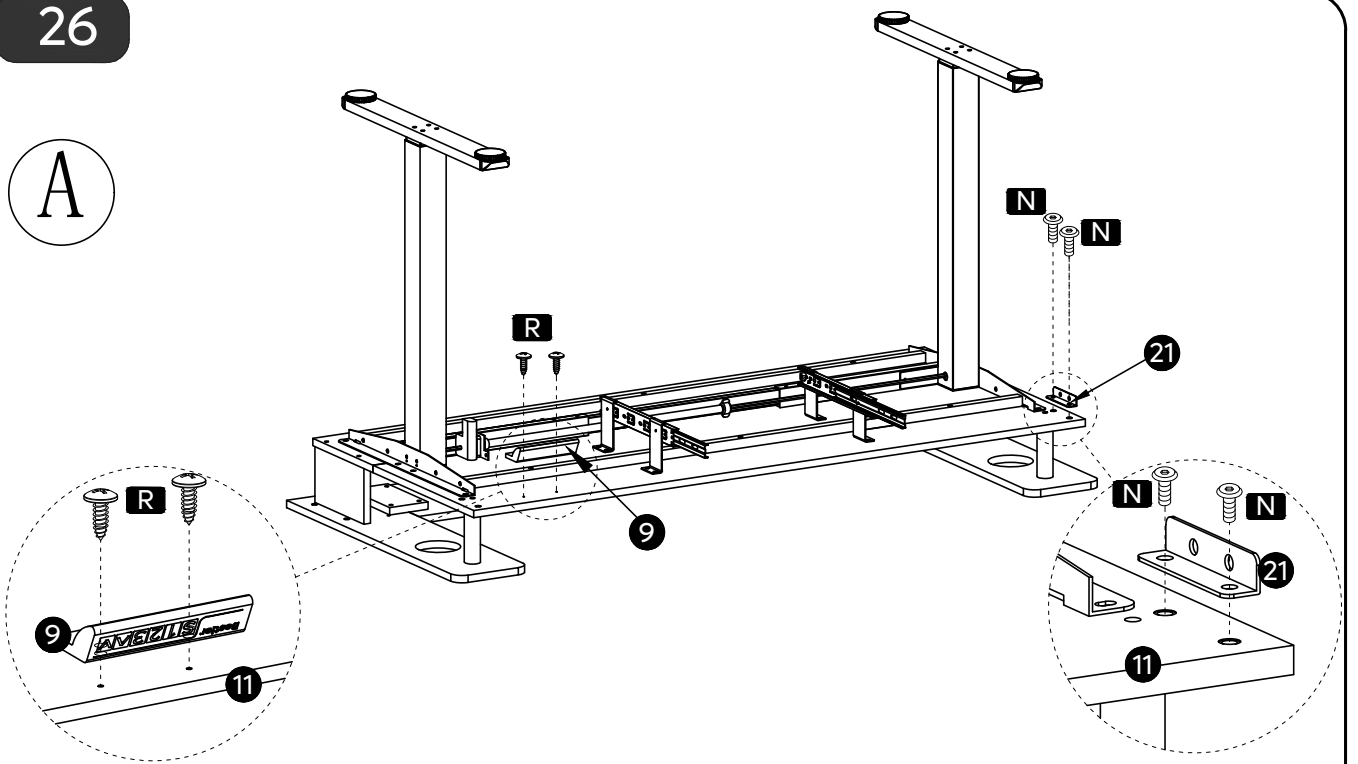

R ST5x14mm

x2



N M6x12mm

x2

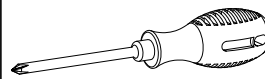

S=4mm

27

A

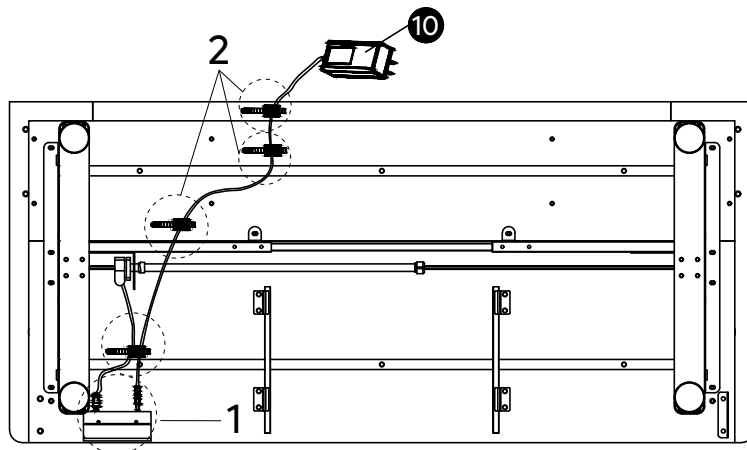

G



x4

1

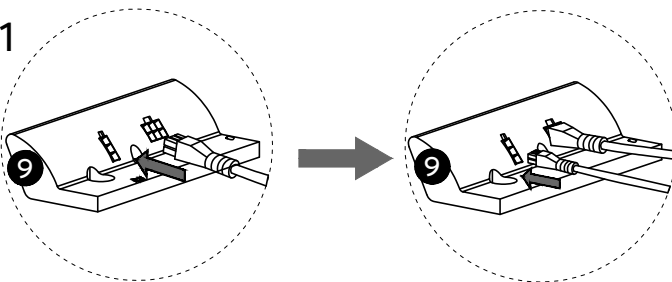

2

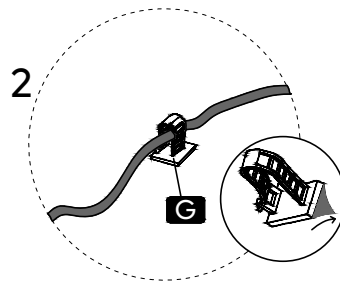

28

A

- ※ Two persons are needed.
- ※ Deux personnes sont nécessaires.
- ※ Zwei Personen sind erforderlich.
- ※ Sono necessarie due persone.
- ※ Se necesitan dos personas.
- ※ 必ず2人で作業してください。
- ※ 需要另外1个人协助。

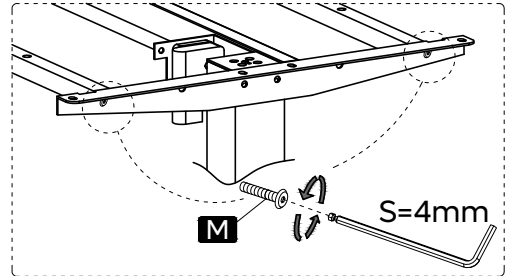
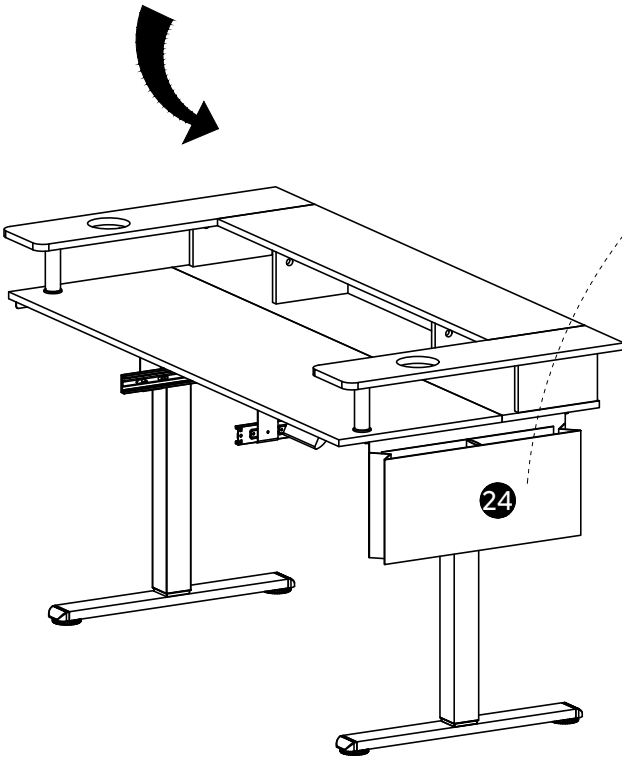
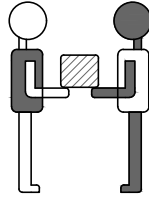

1

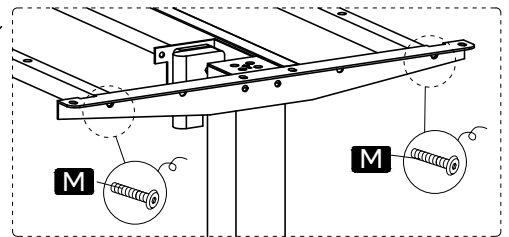

2

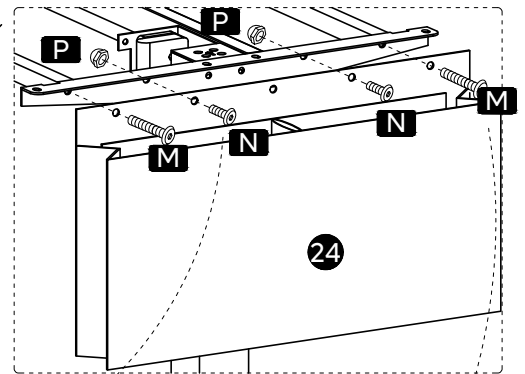

3

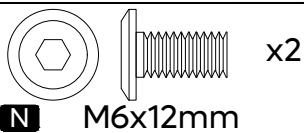
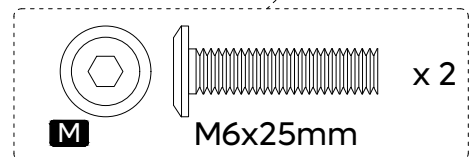
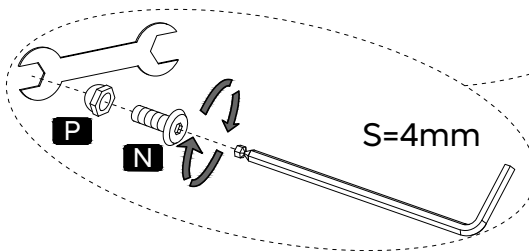

N M6x12mm



P M6mm

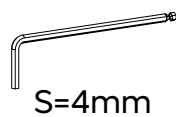

S=4mm

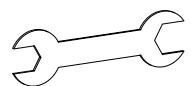

H1024147BUS

29

29

A

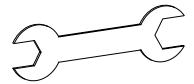
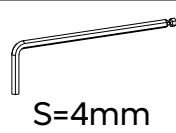
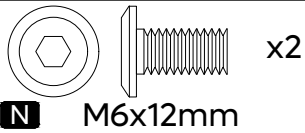
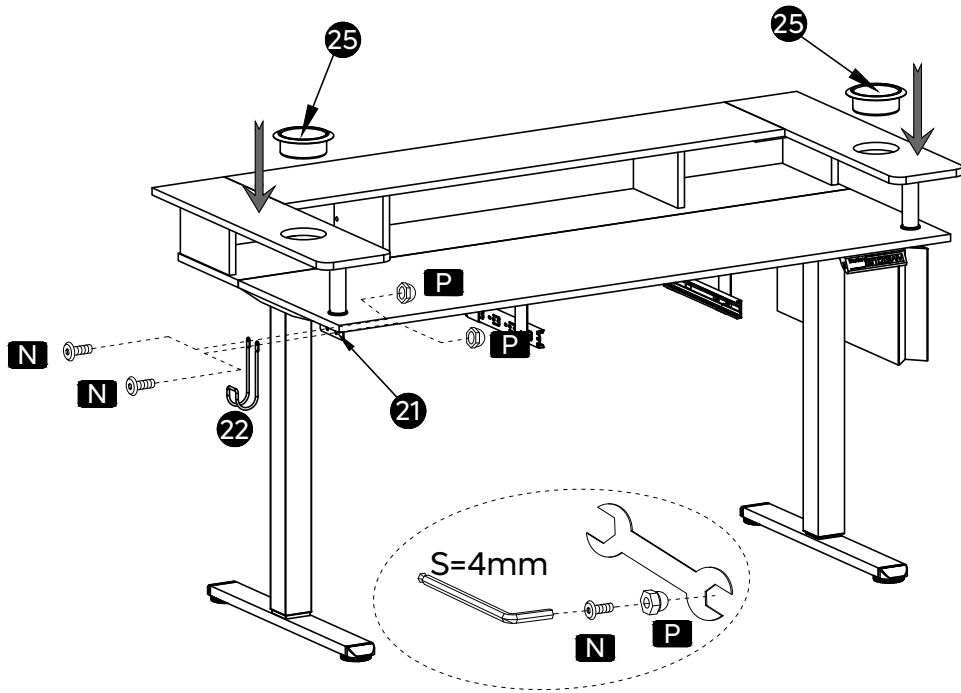

30

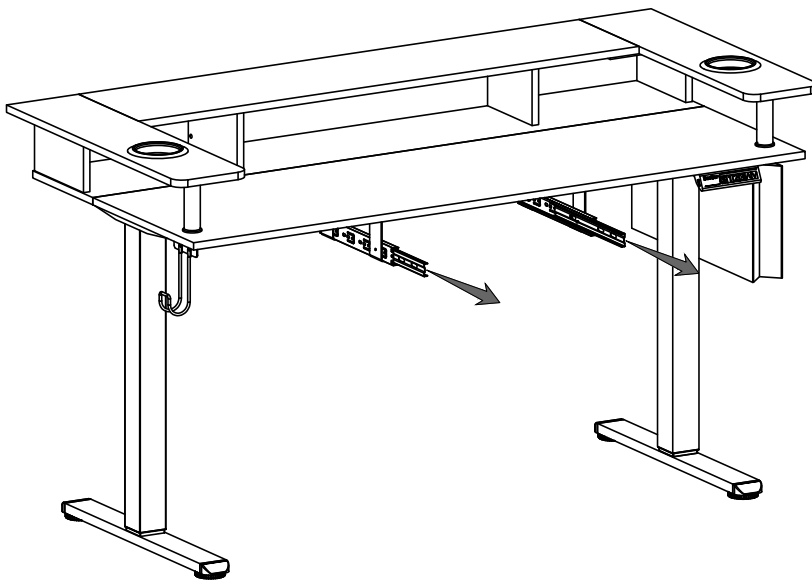

31

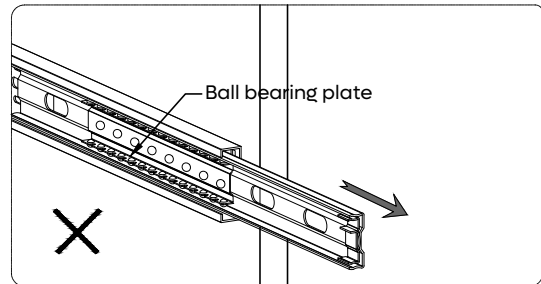
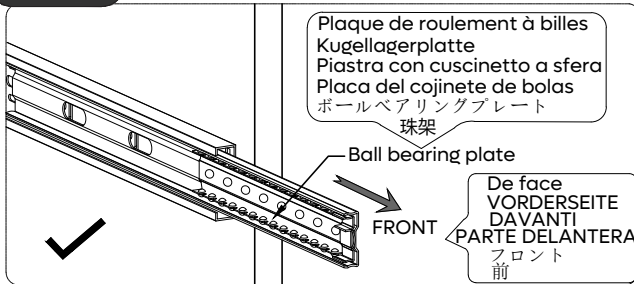

1

※Before inserting the Drawer, make sure to slide the ball bearing plates located on the Side Frames to the FRONT of the unit as illustrated.

※Avant d'insérer le tiroir, assurez-vous de faire glisser les plaques de roulement à billes situées sur les cadres latéraux à l'AVANT de l'unité, comme illustré.

※Bevor Sie die Schublade einsetzen, schieben Sie die Kugellagerplatten an den Seitenrahmen wie abgebildet nach VORN.

※Prima di inserire il cassetto, assicurarsi di far scorrere le piastre con cuscinetto a sfera situate sui telai laterali verso la parte anteriore dell'unità, come illustrato.

※Antes de insertar el cajón, asegúrese de hacer deslizar las placas de los cojinetes de bolas situadas en los marcos laterales hasta la parte FRONTAL de la unidad, como puede verse en la ilustración.

※引き出しを挿入する前に、図のように、サイドフレームにあるボールbearingプレートをユニットの前面にスライドさせてください。

※将两侧板上的导轨球架移至导轨最前端；

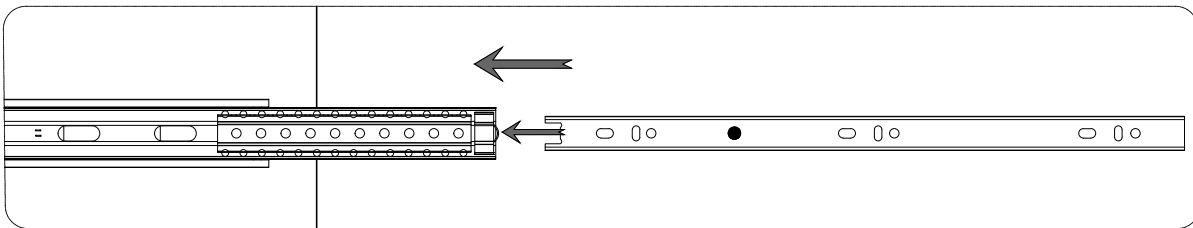

2

※Insert the rails on both sides of the drawer into the ball bearing plate and slowly push in horizontally.

※Insérez les rails des deux côtés du tiroir dans la plaque de roulement à billes et poussez doucement à l'horizontale.

※Führen Sie die Schienen auf beiden Seiten der Schublade in die Kugellagerplatte ein und schieben Sie sie langsam und waagrecht hinein.

※Inserire le guide su entrambi i lati del cassetto nella piastra con cuscinetto a sfera e spingere lentamente in orizzontale.

※Inserte los carriles de ambos lados del cajón en la placa de cojinete de bolas y empuje lentamente en dirección horizontal.

※引き出しの両側にあるレールをボールbearingプレートに差し込み、ゆっくりと水平に押し込みます。

※将抽屉两侧的导轨片，对准导轨最前端，水平缓慢将其推入；

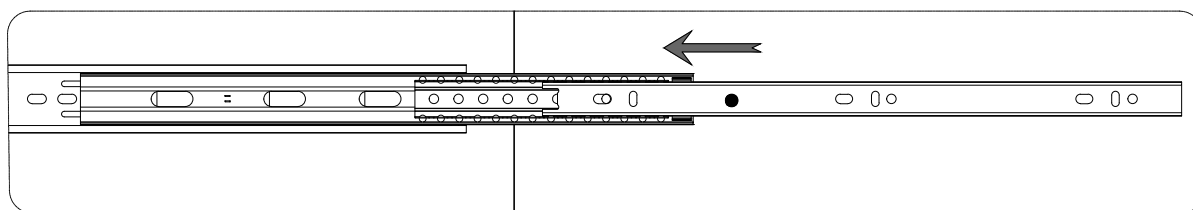

3

※Note: Push in slowly and horizontally.

※Remarque : poussez lentement et à l'horizontale.

※Hinweis: Schieben Sie sie langsam und waagrecht ein.

※Nota: Spingere lentamente e orizzontalmente.

※Nota Empuje lenta y horizontalmente.

※注意: ゆっくり水平に押し込みます。

※注意: 水平缓慢推入。

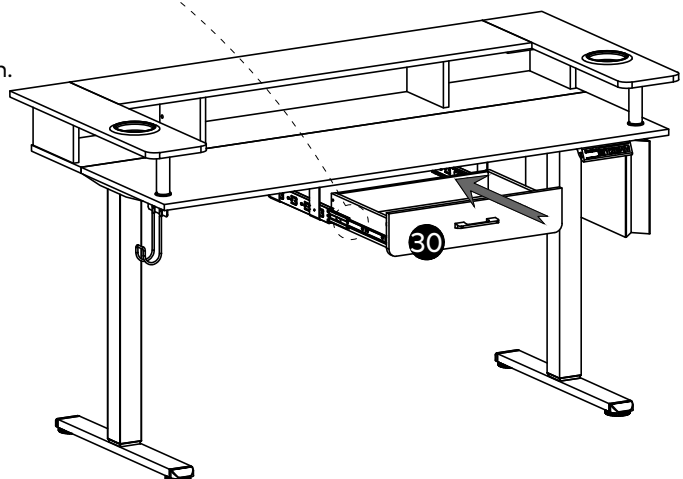

32

B

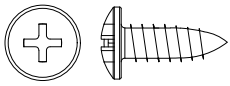
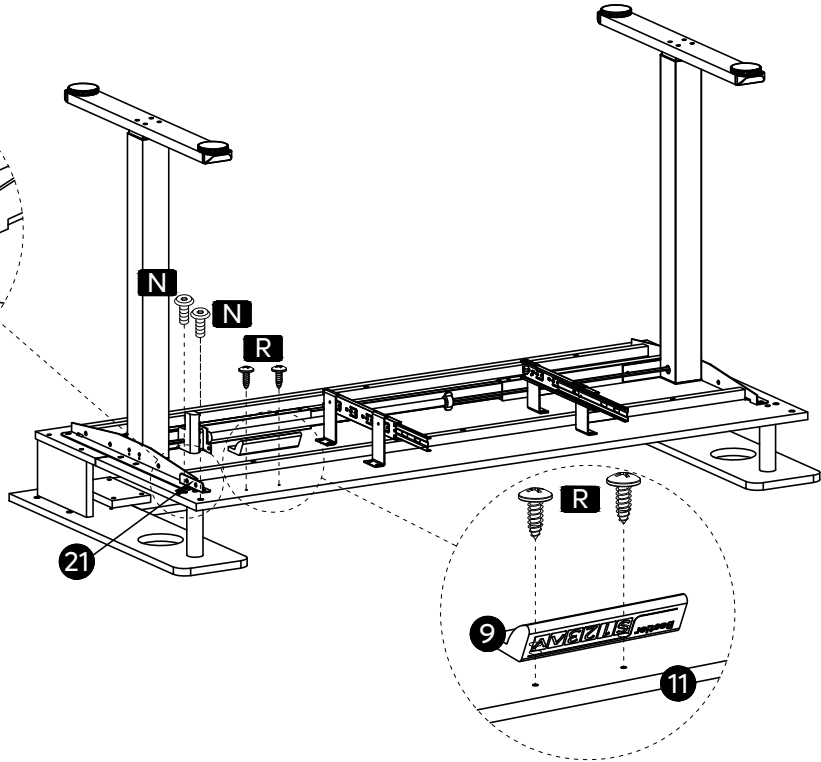
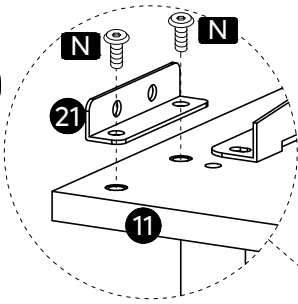

x2

R ST5x14mm



x2

N M6x12mm



S=4mm

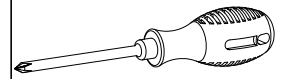

33

B

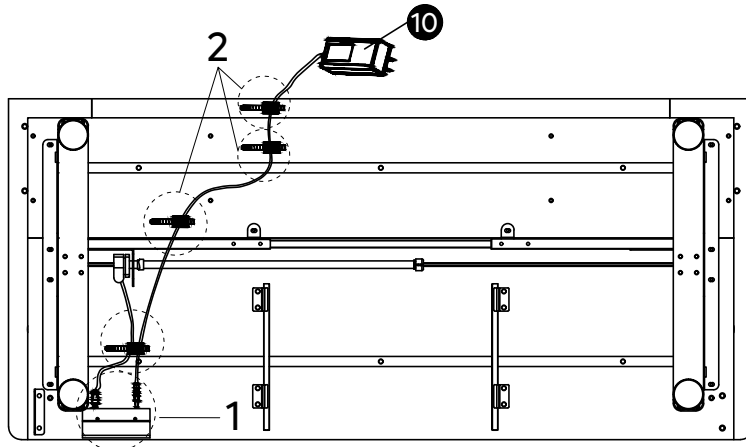

G



x4

1

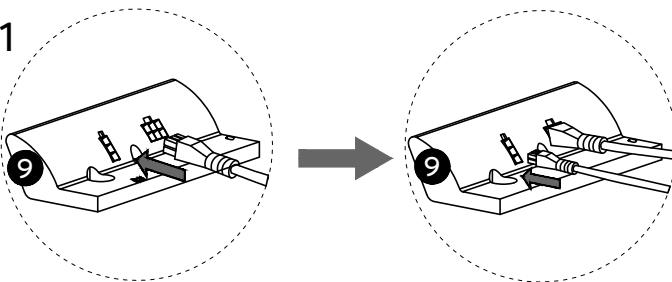

2

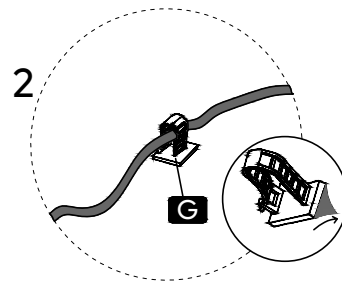

34

- ※ Two persons are needed.
- ※ Deux personnes sont nécessaires.
- ※ Zwei Personen sind erforderlich.
- ※ Sono necessarie due persone.
- ※ Se necesitan dos personas.
- ※ 必ず2人で作業してください。
- ※ 需要另外1个人协助。

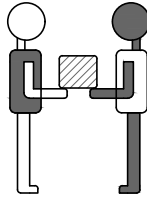

B

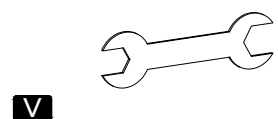
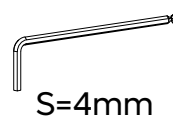
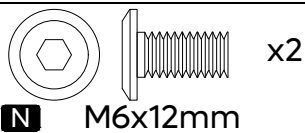
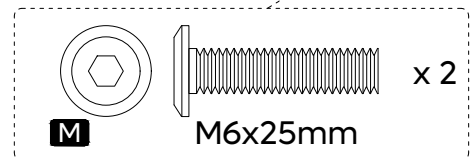
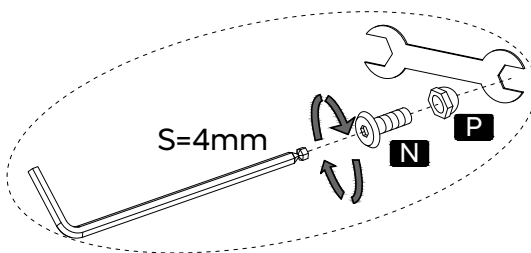
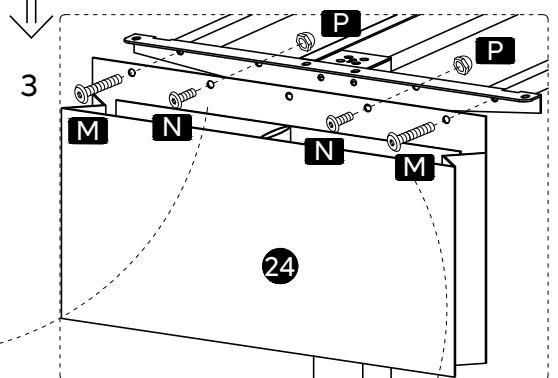
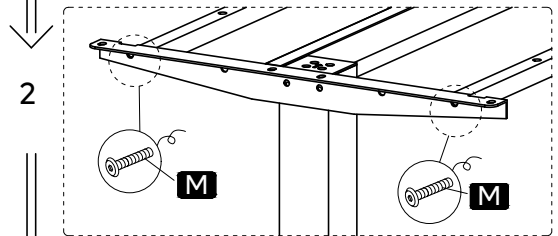
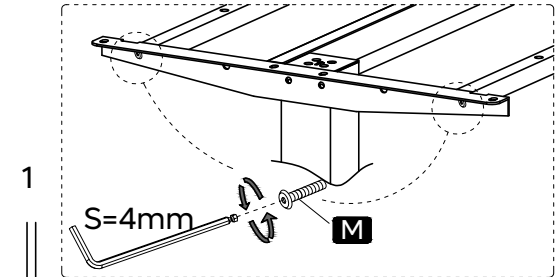
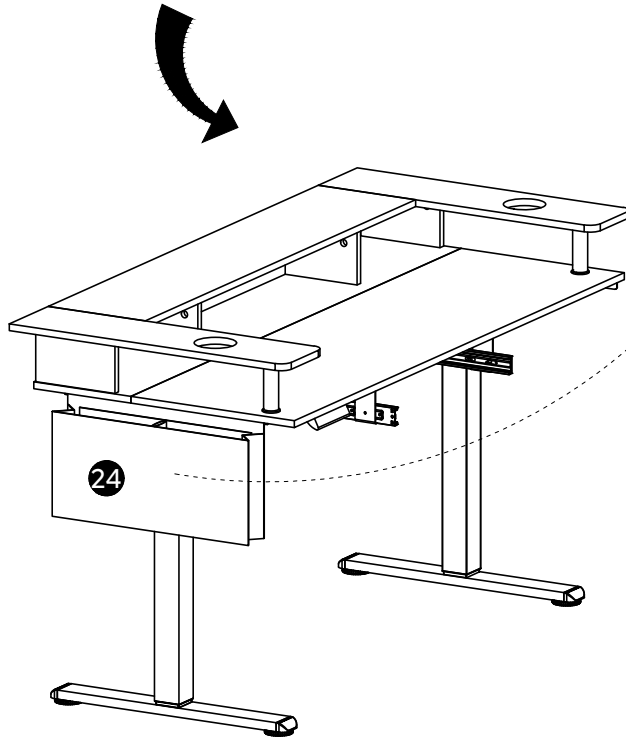

H1024147BUS

35

B

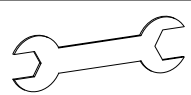
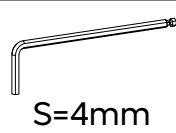
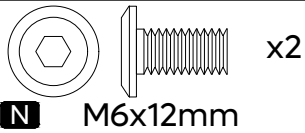
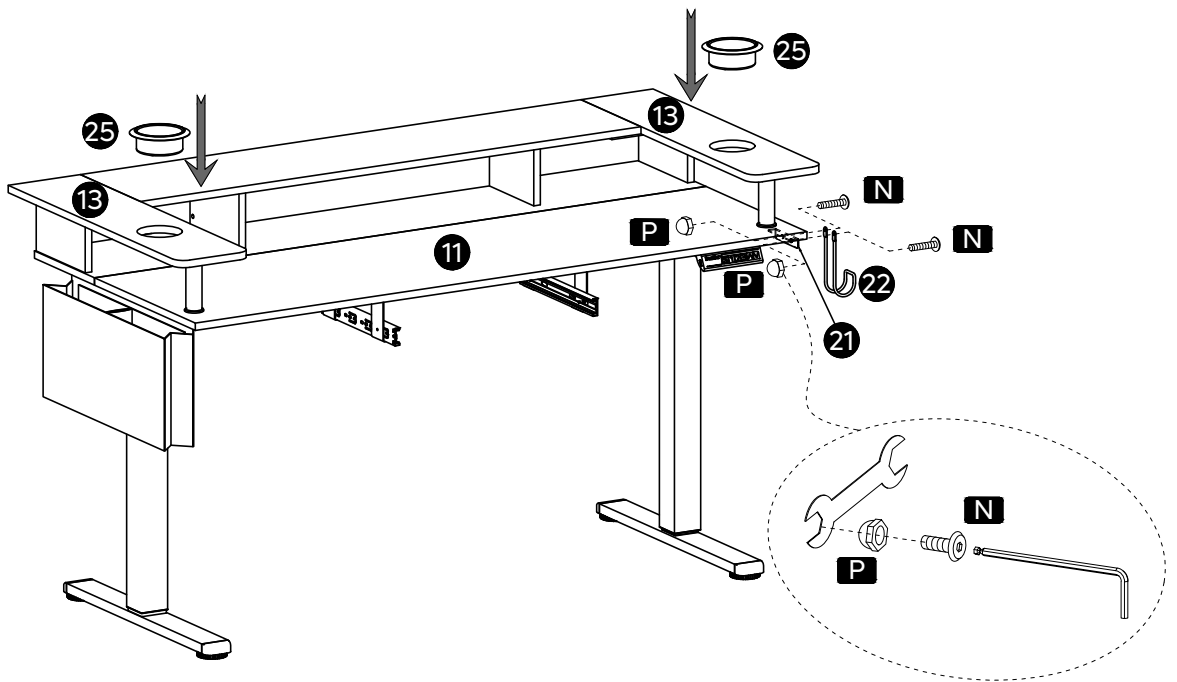

36

B

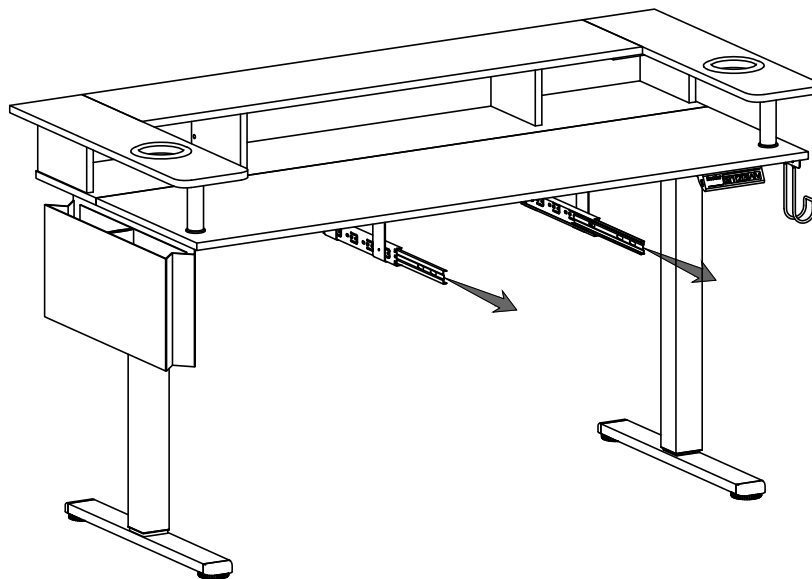

37

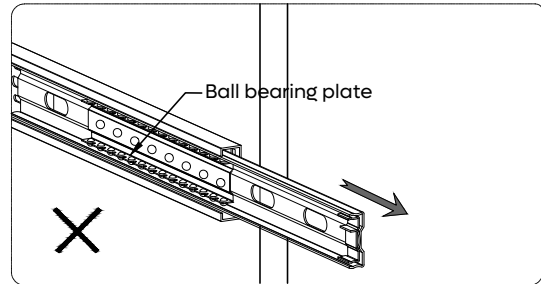
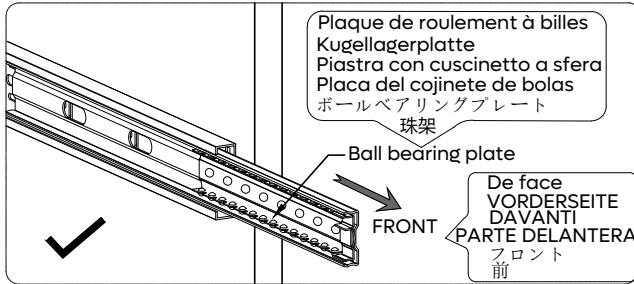

1

※Before inserting the Drawer, make sure to slide the ball bearing plates located on the Side Frames to the FRONT of the unit as illustrated.

※Avant d'insérer le tiroir, assurez-vous de faire glisser les plaques de roulement à billes situées sur les cadres latéraux à l'AVANT de l'unité, comme illustré.

※Bevor Sie die Schublade einsetzen, schieben Sie die Kugellagerplatten an den Seitenrahmen wie abgebildet nach VORN.

※Prima di inserire il cassetto, assicurarsi di far scorrere le piastre con cuscinetto a sfera situate sui telai laterali verso la parte anteriore dell'unità, come illustrato.

※Antes de insertar el cajón, asegúrese de hacer deslizar las placas de los cojinetes de bolas situadas en los marcos laterales hasta la parte FRONTAL de la unidad, como puede verse en la ilustración.

※引き出しを挿入する前に、図のように、サイドフレームにあるボールベアリングプレートをユニットの前面にスライドさせてください。

※将两侧板上的导轨珠架移至导轨最前端；

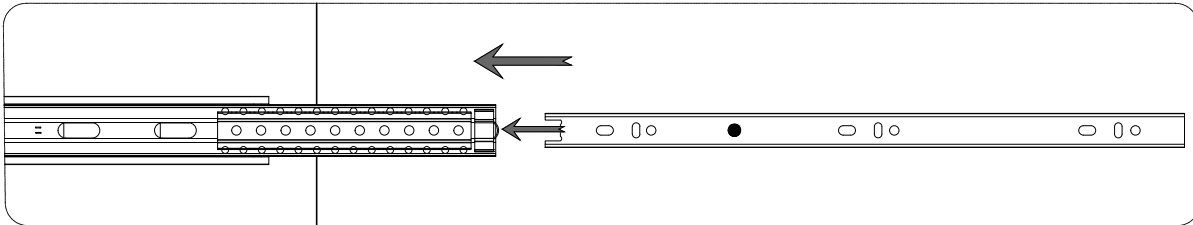

2

※Insert the rails on both sides of the drawer into the ball bearing plate and slowly push in horizontally.

※Insérez les rails des deux côtés du tiroir dans la plaque de roulement à billes et poussez doucement à l'horizontale.

※Führen Sie die Schienen auf beiden Seiten der Schublade in die Kugellagerplatte ein und schieben Sie sie langsam und waagrecht hinein.

※Inserire le guide su entrambi i lati del cassetto nella piastra con cuscinetto a sfera e spingere lentamente in orizzontale.

※Inserte los carriles de ambos lados del cajón en la placa de cojinete de bolas y empuje lentamente en dirección horizontal.

※引き出しの両側にあるレールをボールベアリングプレートに差し込み、ゆっくりと水平に押し込みます。

※将抽屉两侧的导轨片，对准导轨最前端，水平缓慢将其推入；

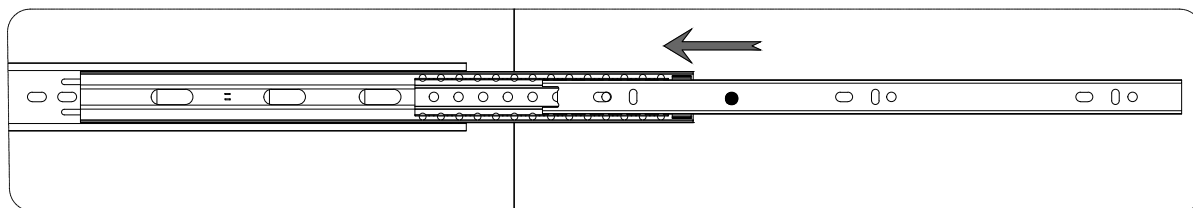

3

※Note: Push in slowly and horizontally.

※Remarque : poussez lentement et à l'horizontale.

※Hinweis: Schieben Sie sie langsam und waagrecht ein.

※Nota: Spingere lentamente e orizzontalmente.

※Nota Empuje lenta y horizontalmente.

※注意: ゆっくり水平に押し込みます。



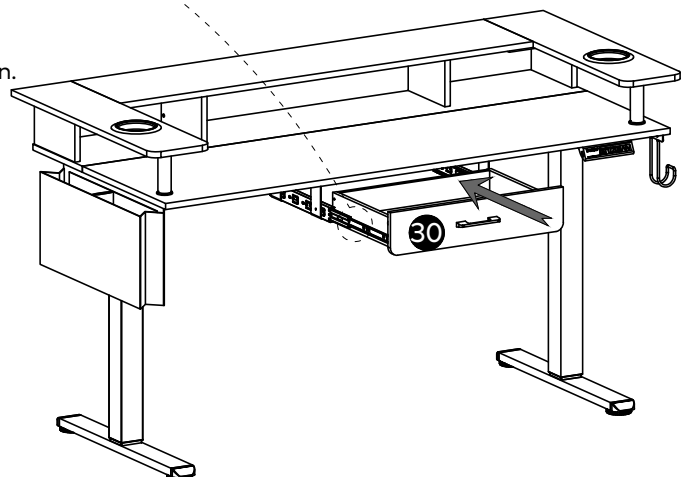









































※注意: 水平缓慢推入。



USING THE CONTROLLER

Utilisation du contrôleur
Bedienung des Controllers
Utilizzo del controller















Usò del controlador
コントローラの使用
控制器的使用















	<ul style="list-style-type: none"> • Short-press the  button, and the display will flash. Press the , , or  button to save the current height setting to that button.
	<ul style="list-style-type: none"> • Press the  button, and the desk will move to the height that was previously set for that button.
	<ul style="list-style-type: none"> • Press the  button, and the desk will move to the height that was previously set for that button.
	<ul style="list-style-type: none"> • Press the  button, and the desk will move to the height that was previously set for that button.
	<ul style="list-style-type: none"> • Press the  button to raise the desk continuously until it reaches the highest position of 46.5" (118cm) or the button is released.
	<ul style="list-style-type: none"> • Press the  button to lower the desk continuously until it reaches the lowest position of 28.3" (72cm) or the button is released.
	<ul style="list-style-type: none"> • Appuyez brièvement sur la touche , et l'affichage clignote. Appuyez sur le bouton , , ou  pour enregistrer le réglage actuel de la hauteur sur ce bouton.
	<ul style="list-style-type: none"> • Appuyez sur le bouton , et le bureau se déplacera à la hauteur précédemment réglée pour ce bouton.
	<ul style="list-style-type: none"> • Appuyez sur le bouton , et le bureau se déplacera à la hauteur précédemment réglée pour ce bouton.
	<ul style="list-style-type: none"> • Appuyez sur le bouton , et le bureau se déplacera à la hauteur précédemment réglée pour ce bouton.
	<ul style="list-style-type: none"> • Appuyer sur le bouton  pour élever le bureau en continu jusqu'à ce qu'il atteigne la position la plus haute de 46,5" (118cm) ou que le bouton soit relâché.
	<ul style="list-style-type: none"> • Appuyez sur le bouton  pour abaisser le bureau en continu jusqu'à ce qu'il atteigne la position la plus basse de 28,3" (72cm) ou que le bouton soit relâché.
	<ul style="list-style-type: none"> • Drücken Sie kurz die Taste  und die Anzeige wird blinken. Drücken Sie auf die Tasten , , oder , um mit dieser Taste die aktuelle Höheneinstellung zu speichern.
	<ul style="list-style-type: none"> • Drücken Sie auf die Taste  und der Schreibtisch wird sich in die zuvor für diese Taste gespeicherte Höhe verstellen.
	<ul style="list-style-type: none"> • Drücken Sie auf die Taste  und der Schreibtisch wird sich in die zuvor für diese Taste gespeicherte Höhe verstellen.
	<ul style="list-style-type: none"> • Drücken Sie auf die Taste  und der Schreibtisch wird sich in die zuvor für diese Taste gespeicherte Höhe verstellen.
	<ul style="list-style-type: none"> • Drücken Sie auf die Taste , um den Schreibtisch stetig zu erhöhen, bis er seine höchste Position von 118 cm (46,5") erreicht hat oder die Taste zuvor losgelassen wird.
	<ul style="list-style-type: none"> • Drücken Sie auf die Taste , um den Schreibtisch stetig zu senken, bis er seine niedrigste Höhe von 72 cm (28,3") erreicht hat oder die Taste zuvor losgelassen wird.















USING THE CONTROLLER

Utilisation du contrôleur
Bedienung des Controllers
Utilizzo del controller

Uso del controlador
コントローラの使用
控制器的使用

	<ul style="list-style-type: none"> ● Premere brevemente il pulsante  e il display lampeggerà. Premere i pulsanti ,  o .
	<ul style="list-style-type: none"> ● Premere il pulsante : la scrivania si regolerà all'altezza precedentemente salvata con quel pulsante.
	<ul style="list-style-type: none"> ● Premere il pulsante : la scrivania si regolerà all'altezza precedentemente salvata con quel pulsante.
	<ul style="list-style-type: none"> ● Premere il pulsante : la scrivania si regolerà all'altezza precedentemente salvata con quel pulsante.
	<ul style="list-style-type: none"> ● Tenere premuto il pulsante  per sollevare la scrivania fino a raggiungere l'altezza massima di 118 cm (46,5"); rilasciando prima il pulsante, la scrivania si ferma.
	<ul style="list-style-type: none"> ● Tenere premuto il pulsante  per abbassare la scrivania fino a toccare l'altezza minima di 72 cm (28,3"); rilasciando prima il pulsante, la scrivania si ferma.















	<ul style="list-style-type: none"> ● Hacer una pulsación corta al botón  y la pantalla parpadeará. Pulsar el botón , , o .
	<ul style="list-style-type: none"> ● Pulsar el botón  y el escritorio se moverá a la altura que había configurada antes en ese botón.
	<ul style="list-style-type: none"> ● Pulsar el botón  y el escritorio se moverá a la altura que había configurada antes en ese botón.
	<ul style="list-style-type: none"> ● Pulsar el botón  y el escritorio se moverá a la altura que había configurada antes en ese botón.
	<ul style="list-style-type: none"> ● Pulsar el botón  hasta elevar el escritorio continuamente hasta que alcance la posición más alta de 118 cm (46,5 pulgadas) o el botón se soltará.
	<ul style="list-style-type: none"> ● Pulsar el botón  para bajar el escritorio continuamente hasta que alcance la posición más baja de 72 cm (28,3 pulgadas) o el botón se soltará.















	<ul style="list-style-type: none"> ●  ボタンを短く押すと、ディスプレイが点滅します。ボタン , , または  を押すと、そのボタンに現在の高さ設定が保存されます。
	<ul style="list-style-type: none"> ● ボタン  を押すと、そのボタンに設定しておいた高さにデスクが移動します。
	<ul style="list-style-type: none"> ● ボタン  を押すと、そのボタンに設定しておいた高さにデスクが移動します。
	<ul style="list-style-type: none"> ● ボタン  を押すと、そのボタンに設定しておいた高さにデスクが移動します。
	<ul style="list-style-type: none"> ●  ボタンを押すと、最高の高さ(46.5"または118cm)になるまで、またはボタンを離すまで、デスクが徐々に上昇します。
	<ul style="list-style-type: none"> ●  ボタンを押すと、最低の高さ(28.3"または72cm)になるまで、またはボタンを離すまで、デスクが徐々に下降します。















USING THE CONTROLLER

Utilisation du contrôleur
Bedienung des Controllers
Utilizzo del controller

Usó del controlador
コントローラの使用
控制器的使用

	•短按  按钮,显示屏会闪烁。按下  、  或  按钮,将当前高度设置保存在该按钮上。
	•按下  按钮,升降桌将移动到之前为该按钮设定的高度。
	•按下  按钮,升降桌将移动到之前为该按钮设定的高度。
	•按下  按钮,升降桌将移动到之前为该按钮设定的高度。
	•按下  按钮,升降桌将持续升高,直至达到最高位置46.5英寸(118厘米)或松开按钮。
	•按下  按钮可连续降低升降桌,直至达到最低位置28.3英寸(72厘米)或松开按钮。













Settings		Paramètres Einstellungen Impostazioni	Configuraciones 設定 设置
Change Display Height Units	Press and hold the  button until a flashing'S'-is displayed. Press  again, and'Un'is displayed. Press  to select it, press  or  to switch between'IN'(imperial) and'SI'(metric), and press  to save your choice.		
Change Collision Detection Sensitivity	Press and hold the  button until a flashing'S'-is displayed. Press  again, and'Un'is displayed. Press  or  to switch to'CF'and press  to select it. Press  or  to switch between off, low, normal, and high sensitivity. Press  to save your choice.		
Reset	Press and hold the  button for 5 seconds, and the screen will show'RES.'Continue holding until the desk goes down to its lowest level and comes back up slightly.		















Changement des unités de hauteur d'affichage	Appuyez sur le bouton  et maintenez-le enfoncé jusqu'à ce qu'un "S-" clignotant s'affiche. Appuyez à nouveau sur  , et 'Un' s'affiche. Appuyez sur  pour le sélectionner, appuyez sur  ou  pour basculer entre 'IN'(impérial) et 'SI' (métrique), et appuyez sur  pour enregistrer votre choix.
Changement de la sensibilité de la détection de collision	Appuyez sur le bouton  et maintenez-le enfoncé jusqu'à ce qu'un "S-" clignotant s'affiche. Appuyez à nouveau sur  , et 'Un' s'affiche. Appuyez sur  ou  pour passer à 'CF'et appuyez sur pour le sélectionner. Appuyez sur  ou  pour basculer entre la sensibilité désactivée, faible, normale et élevée. Appuyez sur  pour enregistrer votre choix.
Réinitialisation	Appuyez sur le bouton  et maintenez-le enfoncé pendant 5 secondes ; l'écran affiche alors "RES. "Maintenez-le enfoncé jusqu'à ce que le pupitre descende à son niveau le plus bas et remonte légèrement.















USING THE CONTROLLER

Utilisation du contrôleur
Bedienung des Controllers
Utilizzo del controller

Uso del controlador
コントローラの使用
控制器的使用

Höheneinheiten des Displays ändern	Drücken und halten Sie die Taste  , bis ein blinkendes 'S-' angezeigt wird. Drücken Sie erneut auf  , bis 'Un' angezeigt wird. Drücken Sie zur Auswahl auf  oder  , um zwischen 'IN' (imperial) und 'SI' (metrisch) zu wählen und bestätigen Sie Ihre Auswahl mit  .
Ändern der Empfindlichkeit der Kollisionserkennung	Halten Sie die  Taste gedrückt, bis ein blinkendes 'S-' angezeigt wird. Drücken Sie erneut auf  , bis 'Un' angezeigt wird. Drücken Sie auf  oder  , um zu 'CF' zu wechseln und wählen Sie es per Tastendruck aus. Drücken Sie auf  oder  , um zwischen Aus, Niedriger, Normaler und Hoher Empfindlichkeit auszuwählen. Drücken Sie auf  , um Ihre Auswahl zu speichern.
Zurücksetzen	Halten Sie die  Taste 5 Sekunden gedrückt, bis auf dem Display 'RES' erscheint und der Schreibtisch in seine niedrigste Höhe hinunterfährt und langsam wieder hochfährt.

Modifica delle unità di misura dell'altezza sul display	Tenere premuto il pulsante  finché non appare una "S" lampeggiante. Premere nuovamente  : lo schermo visualizzerà "Un". Premere ancora  per selezionarla; premere  o  per passare da "IN" (imperiale) a "SI" (metrico decimale). Premere  per salvare la scelta.
Modifica della sensibilità del sensore di collisione	Tenere premuto il pulsante  finché non appare una "S" lampeggiante. Premere nuovamente  : il display mostrerà "Un". Premere  o  per passare a CF; premere per selezionarlo. Premere  o  per cambiare sensibilità: off, bassa, normale o alta. Premere  per salvare il livello selezionato.
Reimpostazione	Tenere premuto per 5 secondi il pulsante  : il display mostrerà "RES". Continuare a tenere premuto finché la scrivania non scende all'altezza minima e risale leggermente.

Cambiar las unidades de altura de la pantalla	Pulsar el botón  hasta que se muestre la 'S-' parpadeante. Pulsar  de nuevo hasta que se muestre 'Un'. Pulsar  para seleccionarlo y pulsar  o  para cambiar entre el sistema imperial o el métrico: 'IN' (imperial) o 'SI' (métrico). Pulsar  para guardar su elección.
Cambiar la sensibilidad de detección de colisiones	Pulsar el botón  hasta que se muestre la 'S-' parpadeante. Pulsar  de nuevo, y se mostrará 'Un'. Pulsar  o  para cambiar a 'CF' y pulsar para seleccionarlo. Pulsar  o  para cambiar entre apagado, bajo, normal y alta sensibilidad. Pulsar  para guardar su elección.
Reiniciar	Pulsar el botón  y mantenerlo pulsado durante 5 segundos, la pantalla mostrará 'RES'. Seguir pulsando el botón hasta que el escritorio baje a su posición más baja y luego volver a a subirlo un poco.

USING THE CONTROLLER

Utilisation du contrôleur
Bedienung des Controllers
Utilizzo del controller

Uso del controlador
コントローラの使用
控制器的使用

ディスプレイの高さの単位を変更	「S-」の表示が点滅するまで、 <input type="button" value="S"/> ボタンを押したままにします。 <input type="button" value="S"/> をもう一度押すと、「Un」が表示されます。 <input type="button" value="S"/> を押してそれを選択し、 <input type="button" value="IN"/> または <input type="button" value="SI"/> ボタンを押して「IN」（英単位）と「SI」（メートル単位）を切り替え、 <input type="button" value="S"/> を押して設定内容を保存します。
衝突検知感度を変更	「S-」の表示が点滅するまで、 <input type="button" value="S"/> ボタンを押したままにします。 <input type="button" value="S"/> をもう一度押すと、「Un」が表示されます。 <input type="button" value="CF"/> または <input type="button" value="CF"/> を押して「CF」に切り替え、それを押して選択します。 <input type="button" value="CF"/> または <input type="button" value="CF"/> を押してオフ、低感度、通常感度、または高感度に切り替えます。 <input type="button" value="S"/> を押して選択内容を保存します。
リセット	<input type="button" value="RES"/> ボタンを5秒間押したままにすると、画面に「RES」が表示されます。デスクが最低の高さに下がってから少し逆戻りするまで、ボタンを押したままにします。

更改显示屏高度单位	按住 <input type="button" value="S"/> 按钮, 直至显示屏开始闪烁“S-”。再按下 <input type="button" value="S"/> , 显示“Un”。按下 <input type="button" value="S"/> 以选中。按下 <input type="button" value="IN"/> 或 <input type="button" value="SI"/> 在“IN”（英制）和“SI”（公制）之间切换, 并按下 <input type="button" value="S"/> 保存您的选择。
更改碰撞检测灵敏度	按住 <input type="button" value="S"/> 按钮, 直至显示屏开始闪烁“S-”。再按下 <input type="button" value="S"/> , 则显示“Un”。按下 <input type="button" value="CF"/> 或 <input type="button" value="CF"/> 切换到“CF”, 并按下以选中。按下 <input type="button" value="CF"/> 或 <input type="button" value="CF"/> 以在关闭、低、正常和高灵敏度之间切换。按下 <input type="button" value="S"/> 保存您的选择。
重置	按住 <input type="button" value="RES"/> 按钮5秒钟, 屏幕将显示“RES”。继续按住, 直至升降桌下降至最低高度并略微上升。

Protection Mode Error Codes

Hot	Overheating Protection: When the motor has been working continuously for 5 minutes, it will stop operating to prevent damage from overheating. Wait for at least 15 minutes before making any further height adjustment.
E10	Sensor Malfunction Warning: Motor safety sensor can't be detected. Power off, check the connection between the motor and controller, and power back on again.
E20	Overloading Warning: Max load exceeded. If raising the desk, take the things off the desk and try again. If lowering the desk, power off, take the things off the desk, power back on, and try again.
E02	Operation Status Warning: The desk stops moving if vibration, impact, or incline are detected. If this detection is incorrect, follow the reset instructions before continuing use.
E32	Overvoltage Protection: Input voltage too high. If the correct AC adapter is being used, power off the desk, check the connection between power and the controller, and power on again.
E31	Undervoltage Protection: Input voltage too low. If the correct AC adapter is being used, power off the desk, check the connection between power and the controller, and power on again.
-	Cable Disconnection Warning: Check motor and controller cable connections. Normal operation should return once all connectors are properly connected.

Codes d'erreur du mode de protection

Hot	Protection contre la surchauffe : Lorsque le moteur fonctionne en continu depuis 5 minutes, il s'arrête de fonctionner pour éviter tout dommage dû à une surchauffe. Attendez au moins 15 minutes avant de procéder à un nouveau réglage de la hauteur.
E10	Avertissement de dysfonctionnement du capteur : Le capteur de sécurité du moteur ne peut pas être détecté. Mettez hors tension, vérifiez la connexion entre le moteur et le contrôleur, puis remettez sous tension.
E20	Avertissement de surcharge : Charge maximale dépassée. Si vous soulevez le bureau, retirez les objets du bureau et réessayez. Si vous abaissez le bureau, éteignez-le, enlevez les objets du bureau, rallumez-le et réessayez.
E02	Avertissement sur l'état de fonctionnement : Le bureau s'arrête de bouger si des vibrations, des chocs ou une inclinaison sont détectés. Si cette détection est incorrecte, suivez les instructions de réinitialisation avant de poursuivre l'utilisation.
E32	Protection contre la Surchauffe : Tension d'entrée trop élevée. Si l'adaptateur secteur AC utilisé est correct, mettez le bureau hors tension, vérifiez la connexion entre l'alimentation et le contrôleur, puis remettez sous tension.
E31	Protection contre les Sous-tensions : Tension d'entrée trop faible. Si l'adaptateur secteur AC utilisé est correct, mettez le bureau hors tension, vérifiez la connexion entre l'alimentation et le contrôleur, puis remettez sous tension.
-	Avertissement de déconnexion de câble : Vérifiez les connexions des câbles du moteur et du contrôleur. Le fonctionnement normal devrait revenir une fois que tous les connecteurs sont correctement branchés.

Fehlercodes im Schutzmodus

Hot	Überhitzungsschutz: Wenn der Motor 5 Minuten ununterbrochen lief, wird der Betrieb unterbrochen, um Schäden durch Überhitzung zu vermeiden. Warten Sie mindestens 15 Minuten, bevor Sie neue Höhenverstellungen vornehmen.
E10	Warnung vor Sensorfehlfunktionen: Der Motorsicherheitssensor konnte nicht erkannt werden. Schalten Sie das Gerät aus, überprüfen Sie die Verbindung zwischen dem Motor und dem Controller und schalten Sie das Gerät wieder ein.
E20	Warnung vor Überladung: Höchstlast überschritten. Entfernen Sie beim Anheben des Schreibtischs Gegenstände, die auf dem Schreibtisch stehen und versuchen Sie es erneut. Schalten Sie den Schreibtisch beim Absenken aus, entfernen Sie Gegenstände von seiner Oberfläche und schalten Sie ihn nun wieder an, um es erneut zu versuchen.
E02	Warnung zum Betriebsstatus: Der Schreibtisch stoppt, wenn Vibrationen, Stöße oder Neigungen erkannt werden. Wenn ein Fehlalarm vorliegt, befolgen Sie die Anweisungen zum Zurücksetzen, bevor Sie den Schreibtisch erneut verwenden.
E32	Überspannungsschutz: Zu hohe Eingangsspannung. Falls das richtige Netzteil verwendet wird, schalten Sie den Schreibtisch aus, überprüfen die Verbindung zwischen Strom und Controller und schalten ihn wieder ein.
E31	Unterspannungsschutz: Zu niedrige Eingangsspannung. Falls das richtige Netzteil verwendet wird, schalten Sie den Schreibtisch aus, überprüfen die Verbindung zwischen Strom und Controller und schalten ihn wieder ein.
-	Warnung bei getrenntem Kabel: Überprüfen Sie, ob das Kabel am Motor und dem Controller angeschlossen ist. Wenn alle Anschlüsse ordnungsgemäß angeschlossen sind, sollte der Betrieb wieder hergestellt werden.

Codici di errore in modalità protezione

Hot	Protezione dal surriscaldamento: Nel caso il motore sia stato attivo per 5 minuti consecutivi, smetterà di operare per evitare danni da surriscaldamento. Attendere almeno 15 minuti prima di procedere con ulteriori regolazioni in altezza.
E10	Avviso di malfunzionamento del sensore: Non è possibile rilevare il sensore di sicurezza del motore. Spegnerne, verificare il collegamento tra motore e controller e riaccendere.
E20	Avviso di sovraccarico: È stato superato il carico massimo consentito. Se l'avviso appare in fase di sollevamento della scrivania, togliere oggetti dalla superficie e riprovare. Se l'avviso appare in fase di abbassamento della scrivania, spegnere, togliere oggetti dalla superficie, riaccendere e riprovare.
E02	Avviso sullo stato operativo: La scrivania smetterà di muoversi se rileva vibrazioni, impatti o inclinazioni. Nel caso questo avviso sia errato, seguire le istruzioni per il ripristino prima di proseguire.
E32	Protezione dalle sovratensioni: La tensione in ingresso è troppo alta. Nel caso sia utilizzato l'adattatore AC corretto, spegnere la scrivania, verificare il collegamento tra alimentazione e controller e riaccendere.
E31	Protezione dalle sottotensioni: La tensione in ingresso è troppo bassa. Nel caso sia utilizzato l'adattatore AC corretto, spegnere la scrivania, verificare il collegamento tra alimentazione e controller e riaccendere.
-	Avviso di distacco del cavo: Verificare i collegamenti di motore e controller. Il funzionamento dovrebbe tornare regolare una volta ripristinate correttamente tutte le connessioni.

Códigos de error del modo de protección

Hot	Protección de sobrecalentamiento: Cuando el motor ha estado trabajando de manera continuada durante 5 minutos, dejará de funcionar para evitar cualquier daño debido al sobrecalentamiento. Es necesario esperar 15 minutos, como mínimo, antes de volver a hacer algún ajuste a la altura.
E10	Aviso de mal funcionamiento del sensor: No se puede detectar el sensor de seguridad del motor. Apagarlo, comprobar la conexión entre el motor y el controlador y volver a encenderlo.
E20	Aviso de sobrecarga: Se ha excedido la carga máxima. Si se está elevando el escritorio, quitar las cosas del escritorio y volver a intentarlo. Si se está bajando el escritorio, apagarlo, quitar las cosas del escritorio, volver a encenderlo e intentarlo de nuevo.
E02	Aviso del estado de la operación: El escritorio deja de moverse si detecta vibraciones, algún impacto o inclinación. Si esta detección no es correcta, seguir las instrucciones para reiniciarlo antes de seguir utilizándolo.
E32	Protección de sobretensión: El voltaje de entrada es demasiado alto. Si el adaptador de CA que se está usando es el adecuado, desconectar el escritorio, comprobar la conexión entre el subministro de energía y el controlador y volver a conectar el escritorio.
E31	Protección de voltaje bajo: El voltaje de entrada es demasiado bajo. Si el adaptador de CA que se está usando es el adecuado, desconectar el escritorio, comprobar la conexión entre el subministro de energía y el controlador y volver a conectar el escritorio.
-	Aviso de desconexión del cable: Comprobar las conexiones del motor y el cable del controlador. Debería volver a funcionar con normalidad cuando todos los conectores estén conectados correctamente.

保護モードのエラーコード

Hot	過熱保護: モーターが5分間続けて稼働すると、過熱による損傷を防ぐために動作が停止します。15分以上待ってから、高さ調整を再開してください。
E10	センサー誤作動の警告: モーターの安全センサーを検出できません。電源を切り、モーターとコントローラの接続を確認してから、電源を入れ直してください。
E20	過負荷の警告: 最大負荷を超えています。デスクを上昇させている場合は、デスク上の物を取り除いてからもう一度お試しください。デスクを下降させている場合は、電源を切り、デスク上の物を取り除き、電源を入れ直してからもう一度お試しください。
E02	動作ステータスの警告: 振動、衝撃や傾きを検知した場合、デスクの動作が停止します。誤検知である場合は、リセット作業を行ってから使用を再開してください。
E32	過電圧保護: 入力電圧が高すぎます。正しいACアダプタを使用している場合は、デスクの電源を切り、電源とコントローラの接続を確認してから、電源を入れ直してください。
E31	不足電圧保護: 入力電圧が低すぎます。正しいACアダプタを使用している場合は、デスクの電源を切り、電源とコントローラの接続を確認してから、電源を入れ直してください。
-	ケーブル未接続の警告: モーターとコントローラのケーブル接続を確認します。コネクタがすべて正しく接続されたら、通常の動作に戻るはずですが。

保护模式错误代码

Hot	过热保护: 当电机连续工作5分钟后, 它将停止工作, 以防止过热造成的损坏。等待至少15分钟后方可进行进一步的高度调整。
E10	传感器故障警告: 如果无法检测到电机安全传感器, 则关闭电源, 检查电机和控制器之间的连接, 然后重新通电。
E20	超载警告: 超过最大负载。如果提升升降桌, 把物件从升降桌上移除后重试。如果降低升降桌, 请关闭电源, 把物件从升降桌上移除后重新通电并重试。
E02	操作状态警告: 如果检测到振动、冲击或倾斜, 则升降桌停止移动。如果该检测有误, 请在继续使用前按照复位说明进行操作。
E32	过压保护: 输入电压过高。如果使用的是正确的交流适配器, 请关闭升降桌电源, 检查电源和控制器之间的连接, 然后再次通电。
E31	欠压保护: 输入电压太低。如果使用的是正确的交流适配器, 请关闭升降桌电源, 检查电源和控制器之间的连接, 然后再次通电。
-	电缆断线警告: 检查电机和控制器的电缆连接。如果所有接头均正确连接, 则应恢复正常运行。

Bestier



Love coming home.

Comfort Zone Co.,Limited

RM1903 19F BeiYou technology Building, Yuehai Street,
No.42 Gaoxin South Ring Road,Nanshan,Shenzhen

CUSTOMER SUPPORT

North American	Europe	Asia
888-666-1086 Service@bestier.net	Service.UK@bestier.net Service.FR@bestier.net Service.ES@bestier.net	Service.DE@bestier.net Service.IT@bestier.net 04-8888-0283 Service.JP@bestier.net
Global Service@bestier.net		