

FULL BED ASSEMBLY INSTRUCTION

Thank you for purchasing this quality product. Be sure to check all packing material carefully for small parts which may have come loose inside the carton during shipment. Separate, identify and count all parts and hardware. Compare with the parts list to be sure all parts are present.

IMPORTANT : PLEASE READ INSTRUCTION BEFORE STARTING THE ASSEMBLY.

"DO NOT TIGHTEN SCREWS UNTIL COMPLETELY ASSEMBLED"

"DO NOT OVERTIGHT ANY HARDWARE"

WARNING : SMALL PARTS AND HARDWARE NOT FOR CHILDREN UNDER 3 YEARS. ADULT ASSEMBLY REQUIRED.

TABLE OF CONTENTS

HARDWARES LIST	PAGE 2
PARTS LIST	PAGE 3 - 4
PARTS' LOCATION	PAGE 5
ASSEMBLY STEPS	PAGE 6 - 10

ASSEMBLY TOOLS REQUIRED

1.Screwdriver (not provide)

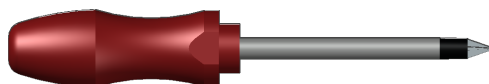

2.Hammer (not provide)

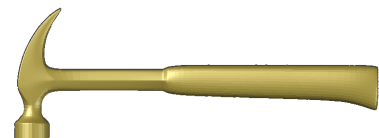





Skip the power drill this time.



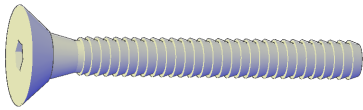
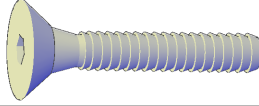
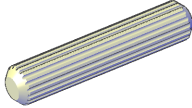

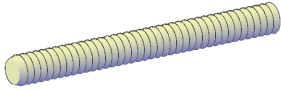
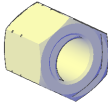

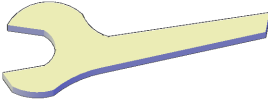
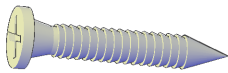
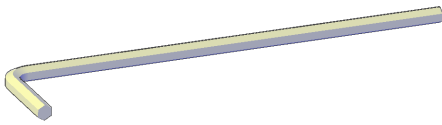
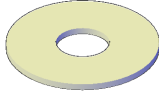
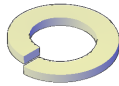
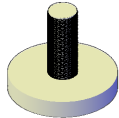
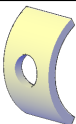
ASSEMBLY INSTRUCTION

HARDWARES LIST

ITEM	DESCRIPTION	DRAWING	QTY
A	JCBC SCREW M6 x 90 MM		4 PCS
B	JCBC SCREW M6 x 40 MM		8 PCS
C	WOOD DOWEL M10 x 40 MM		4 PCS
D	BARREL NUT M6 X 13 MM		4 PCS
E	STUD BOLT M6 x 60 MM		12 PCS
F	HEX NUT M6		12 PCS
G	BEND WASHER Ø7.5 MM		12 PCS
H	SPANNER 10 MM (M6)		1 PC
I	CSK SCREW M4 x 25 MM		8 PCS
J	M4 ALLEN KEY		1 PC
K	M6x19 MM FLAT WASHER		8 PCS
L	M6x12 MM SPRING WASHER		8 PCS
M	SUPPORT LEG ADJUSTABLE FEET		4 PCS
N	BEND WASHER 15 X 25MM		12 PCS

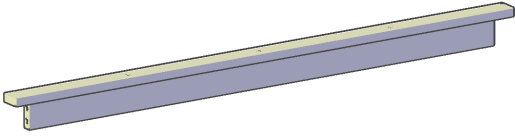
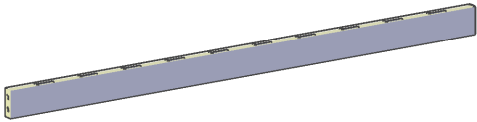
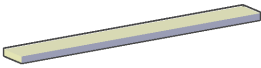
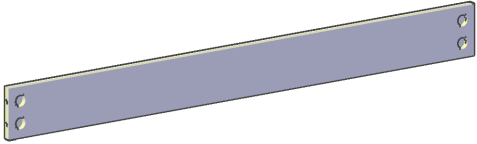
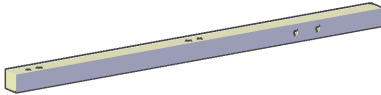
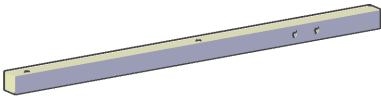

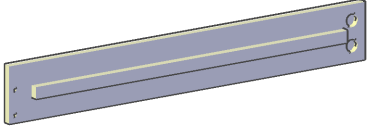
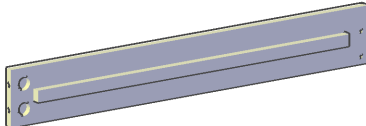
ASSEMBLY INSTRUCTION

PARTS LIST

ITEM	DESCRIPTION	DRAWING	QTY
1	HEADBOARD TOP PANEL		1 PC
2	HEADBOARD BOTTOM PANEL		1 PC
3	HEADBOARD WOODEN STRIPS		10 PCS
4	FOOTBOARD		1 PC
5	HEADBOARD LEG (L)		1 PC
6	HEADBOARD LEG (R)		1 PC
7	FOOTBOARD LEG (L)		1 PC
8	FOOTBOARD LEG (R)		1 PC
9	SIDE RAIL (i)		2 PCS
10	SIDE RAIL (ii)		2 PCS
11	SIDE RAIL LEG		2 PCS

ASSEMBLY INSTRUCTION

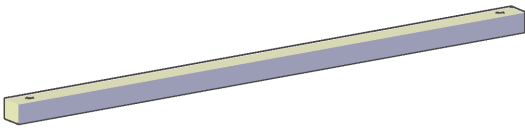
PARTS LIST

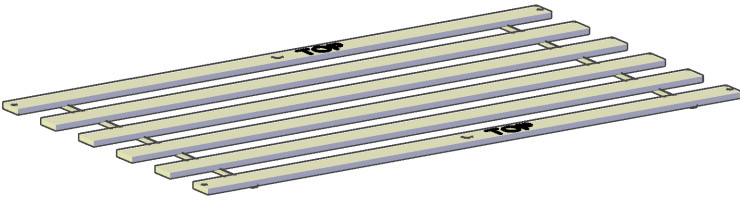
ITEM	DESCRIPTION	DRAWING	QTY
12	SLAT SUPPORT		2 PCS
13	SUPPORT LEG		4 PCS
14	SLAT		2 SET

ASSEMBLY INSTRUCTION

PARTS LOCATION

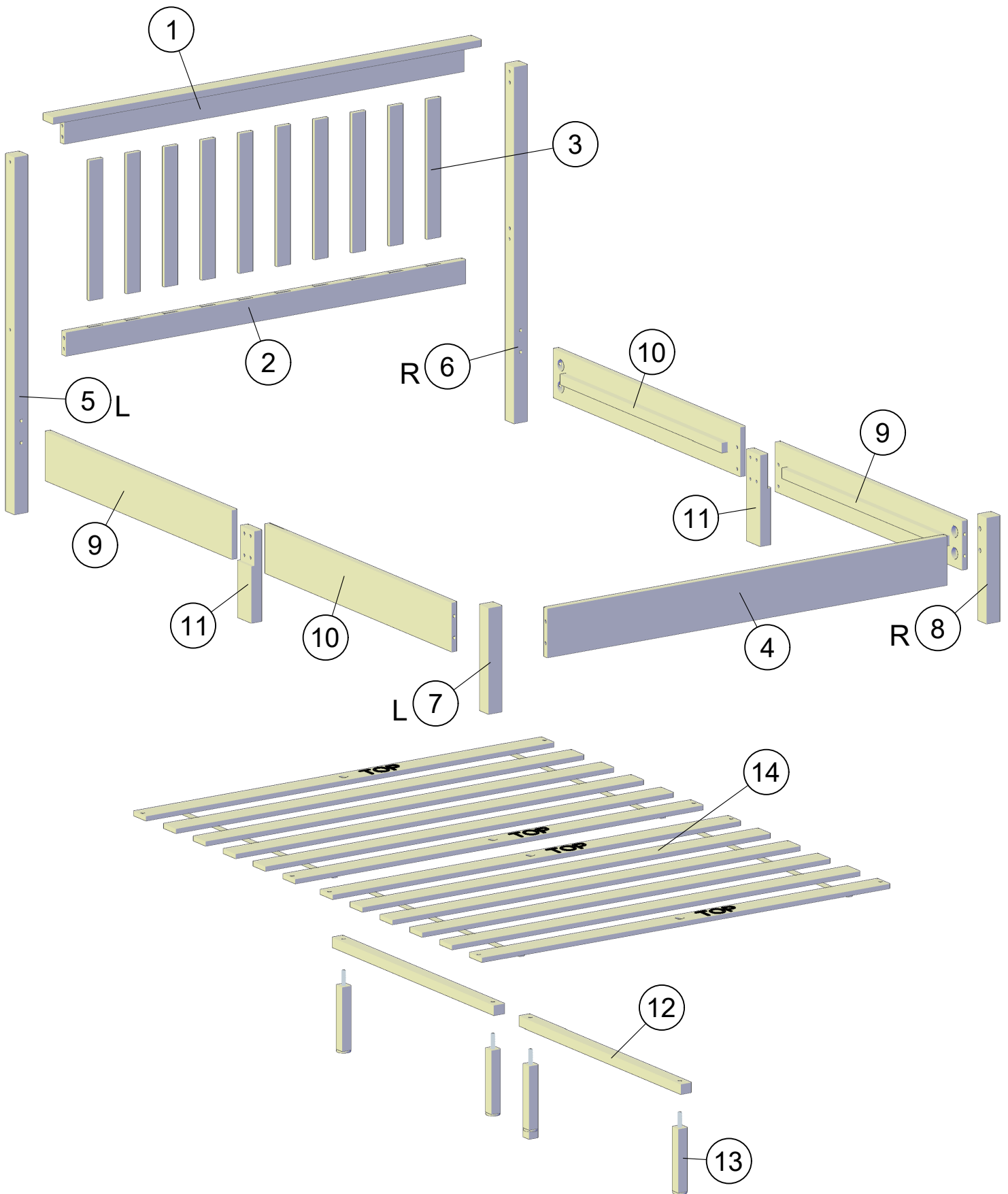

ASSEMBLY INSTRUCTION

STEP 1

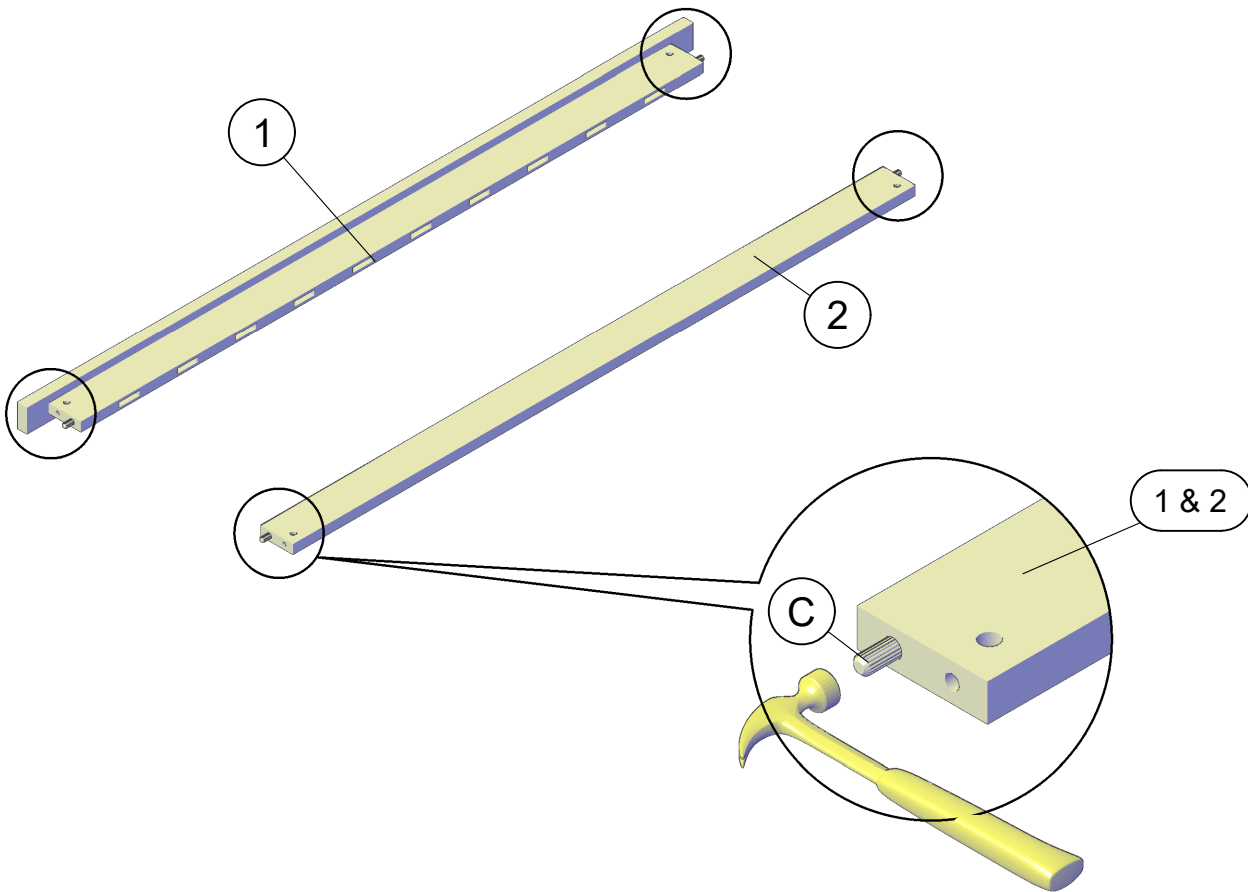

STEP 2

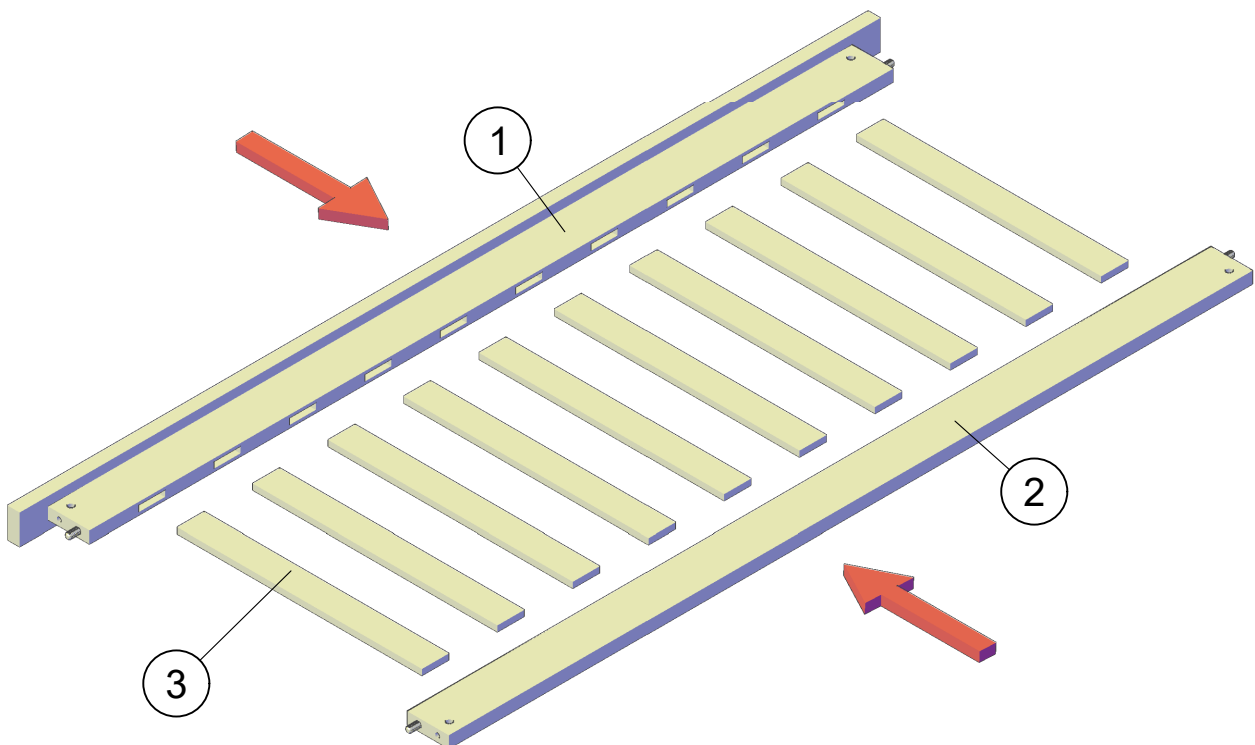

ASSEMBLY INSTRUCTION

STEP 3

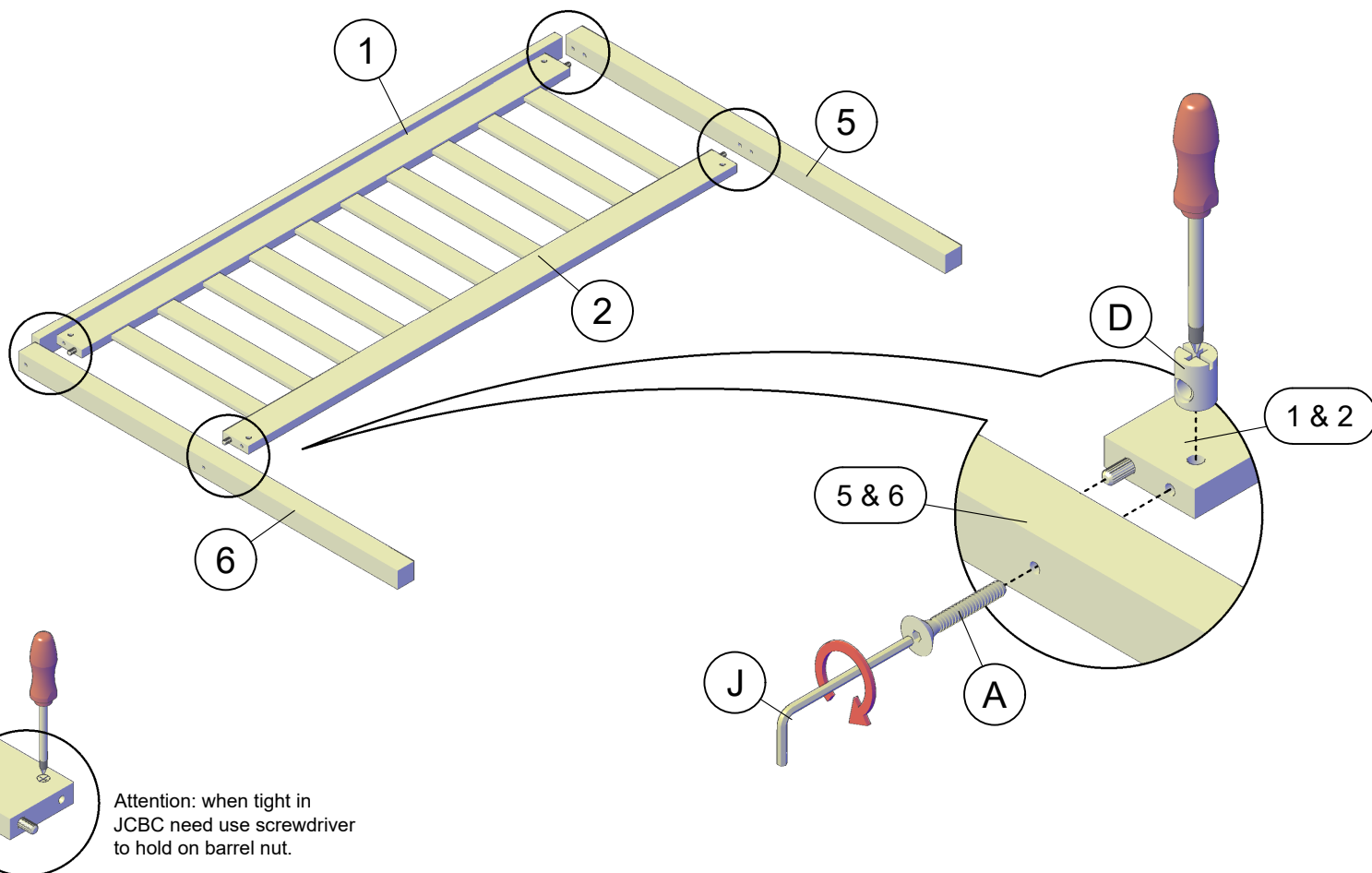

STEP 4

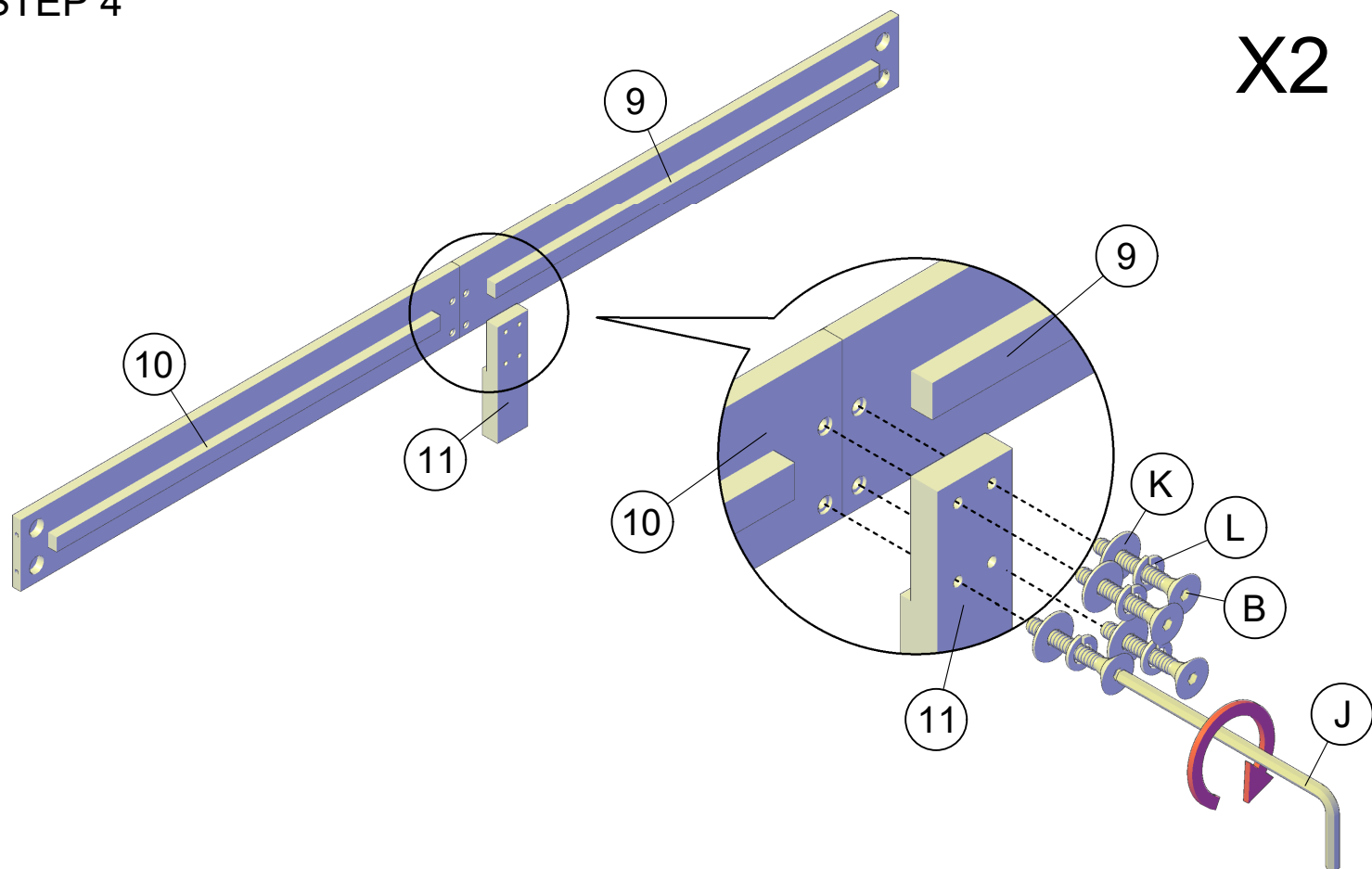

ASSEMBLY INSTRUCTION

STEP 5

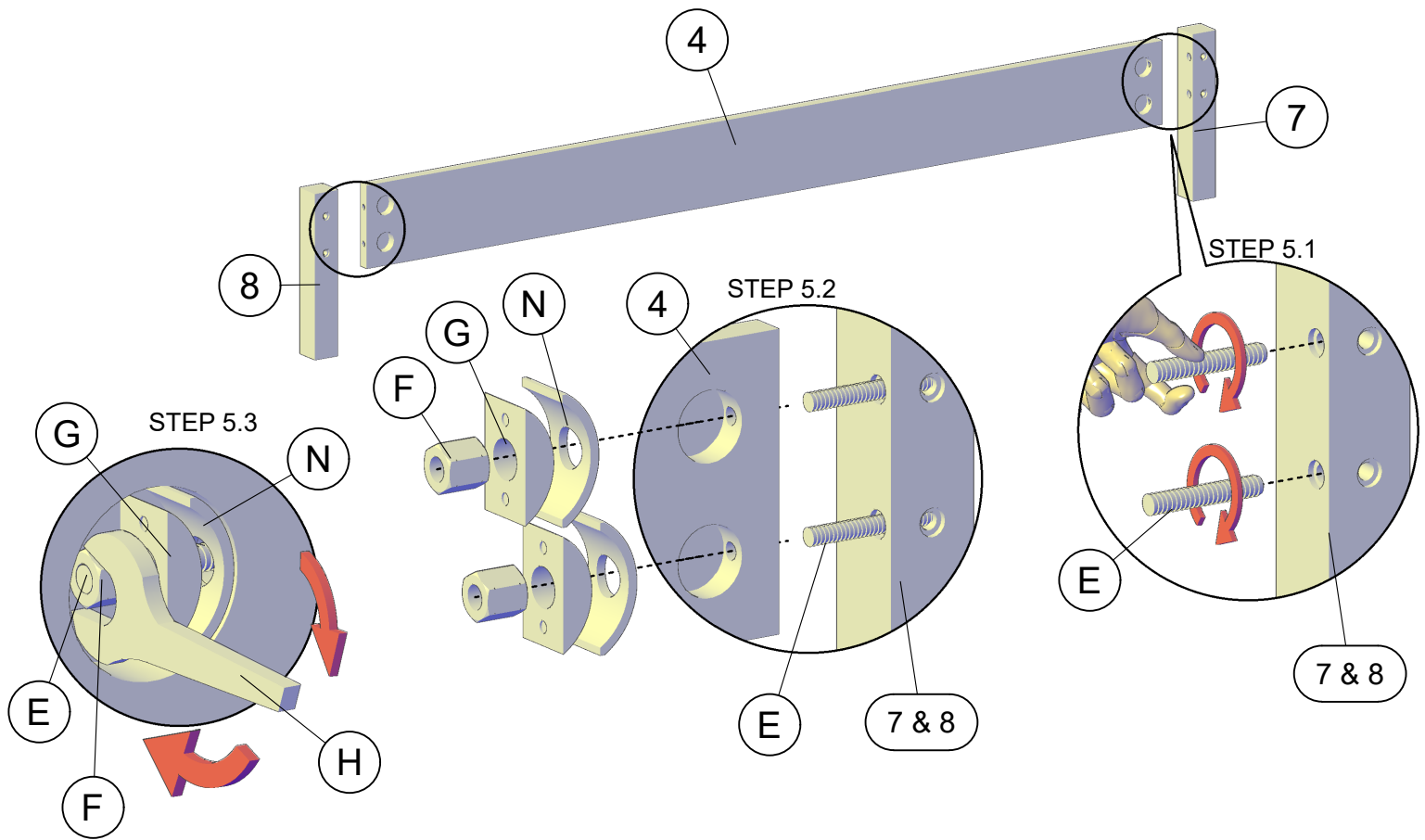

STEP 6

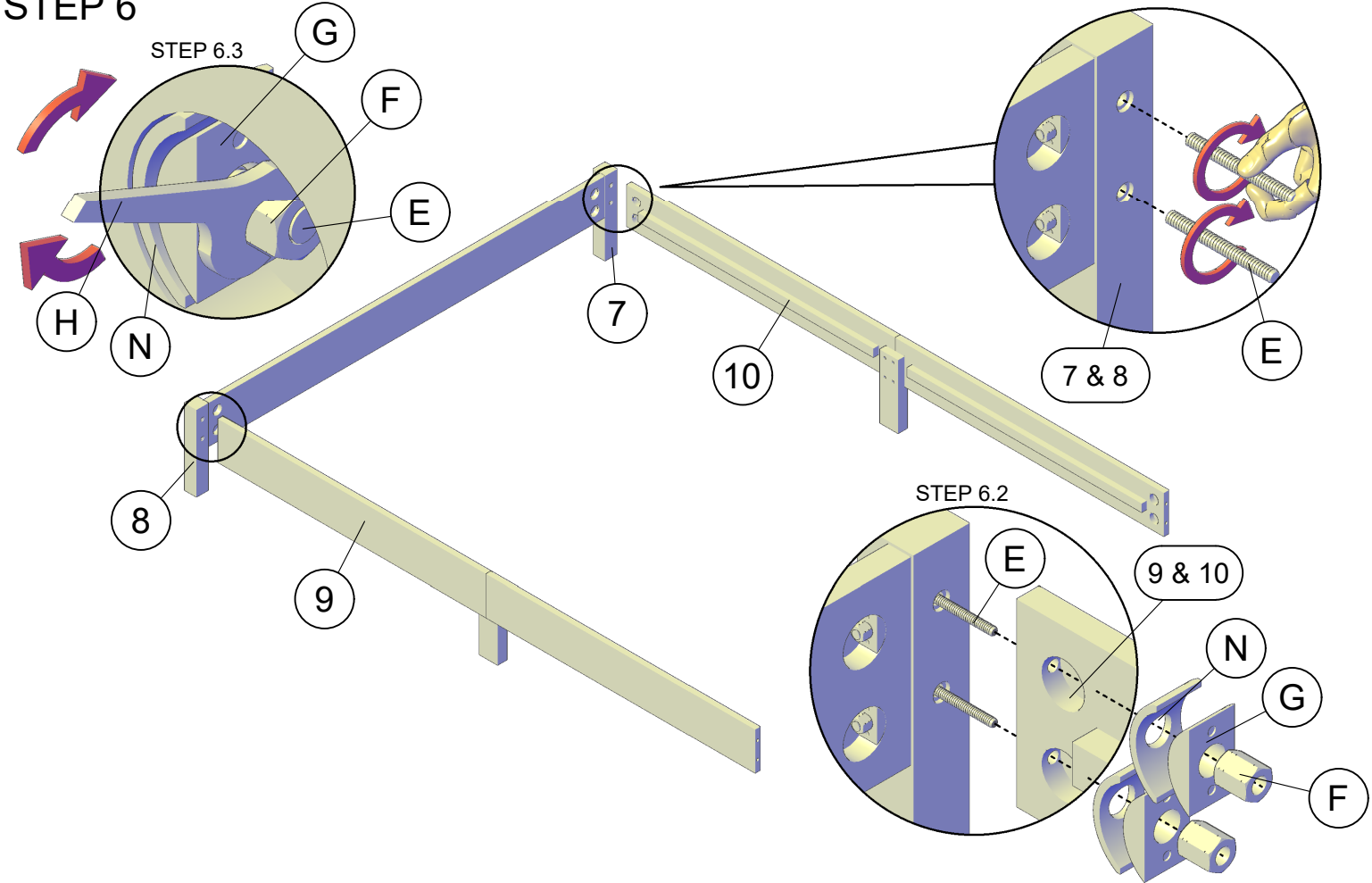

ASSEMBLY INSTRUCTION

STEP 7

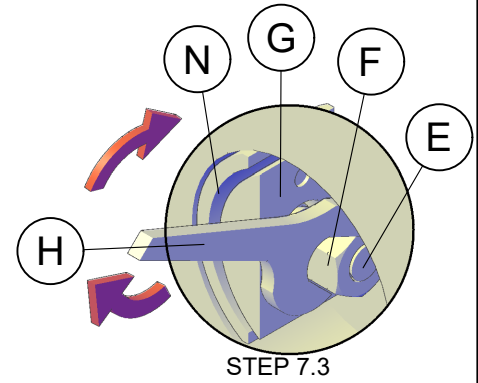
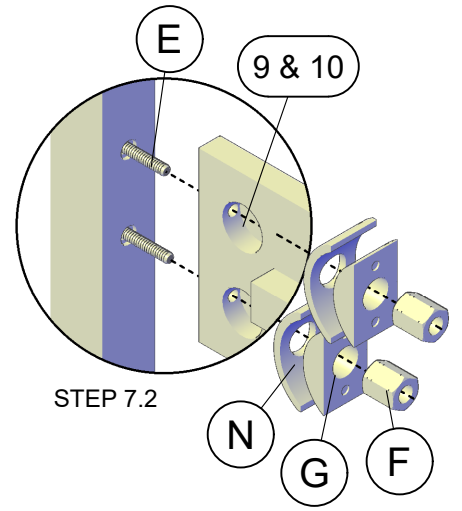
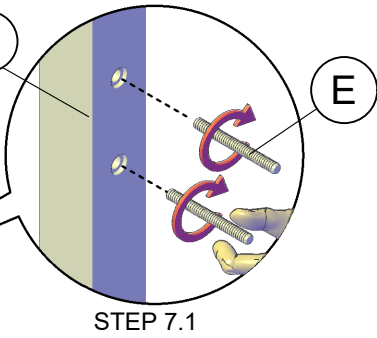
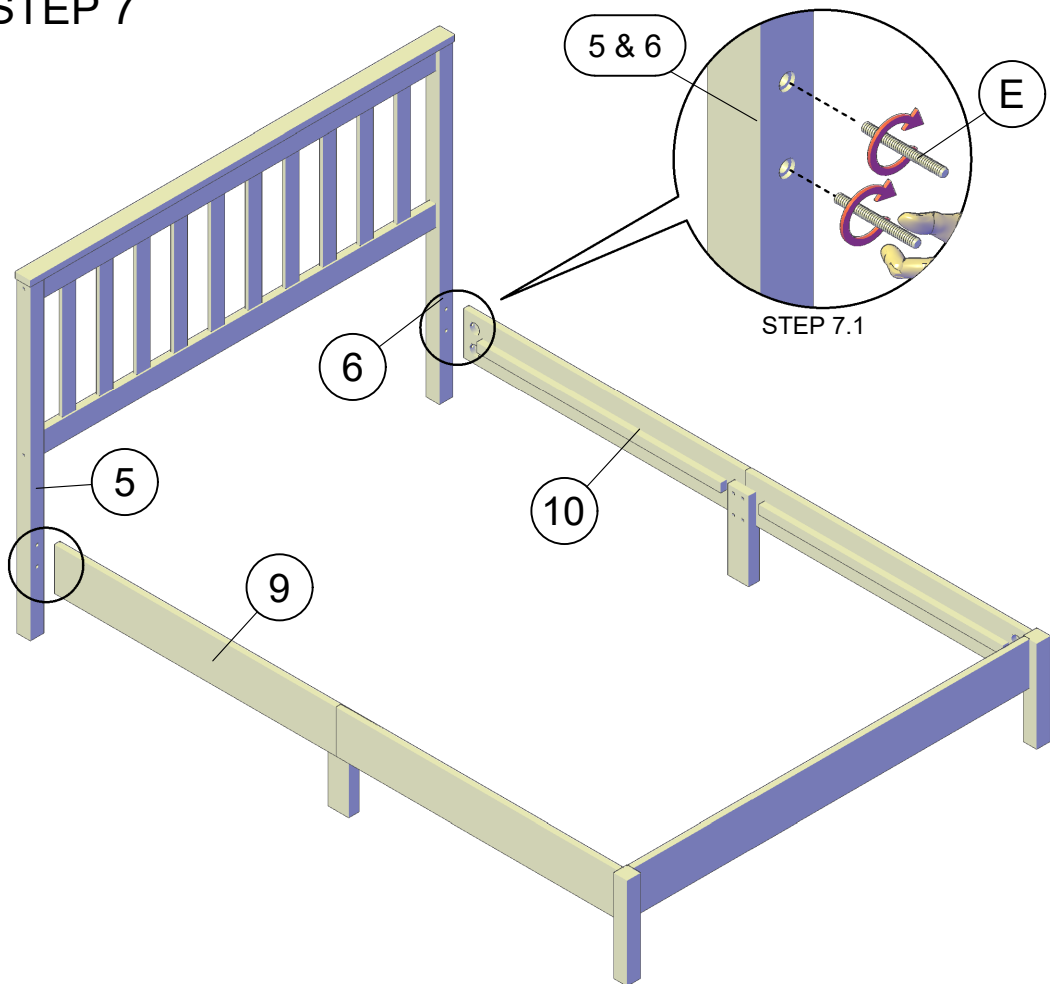

STEP 8

BOTTOM VIEW

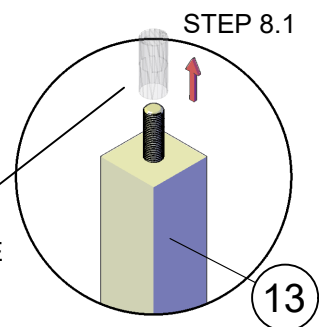
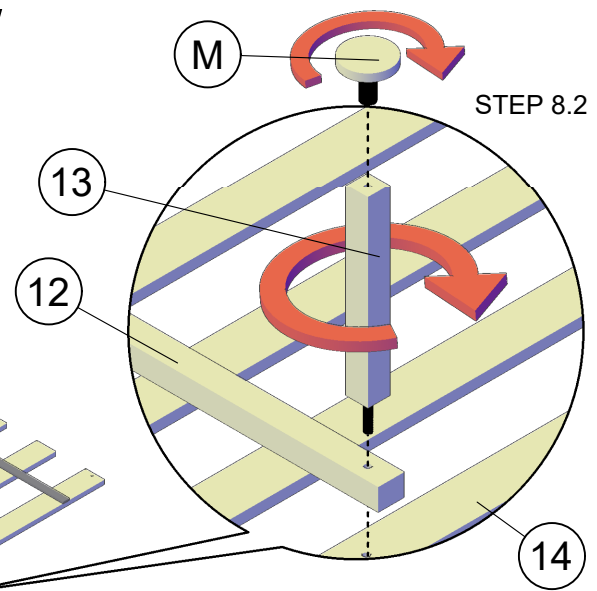
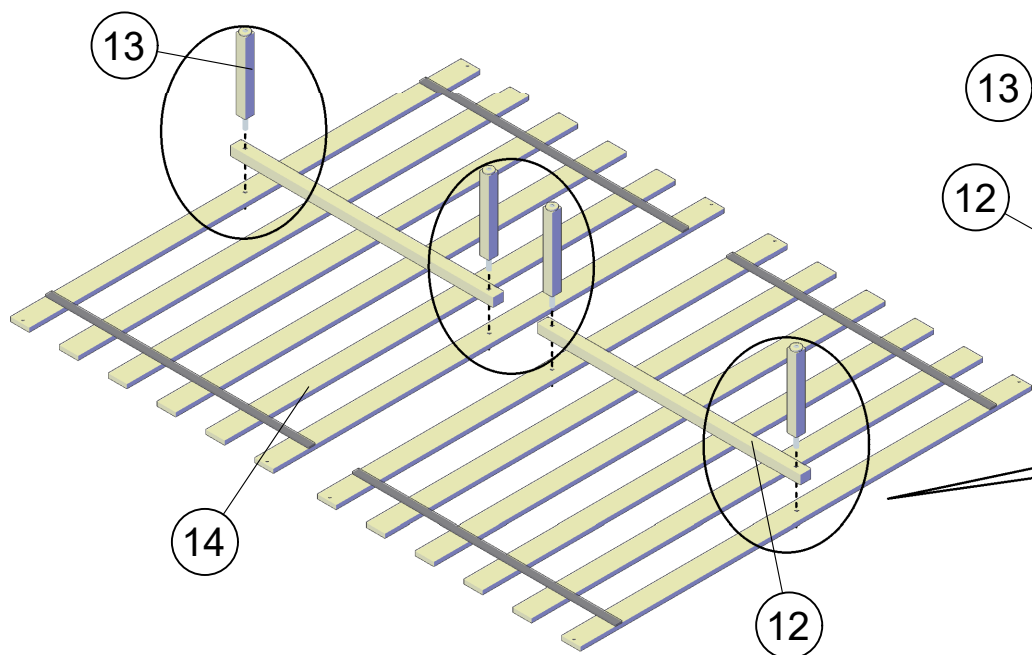

ASSEMBLY INSTRUCTION

STEP 9

Please push the side rail inward to ensure it is fully aligned with both ends of the slats.

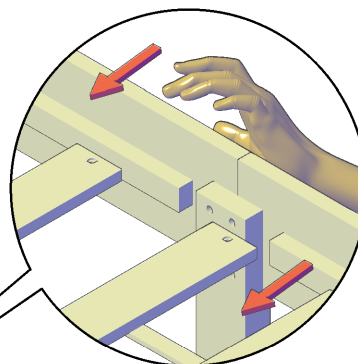
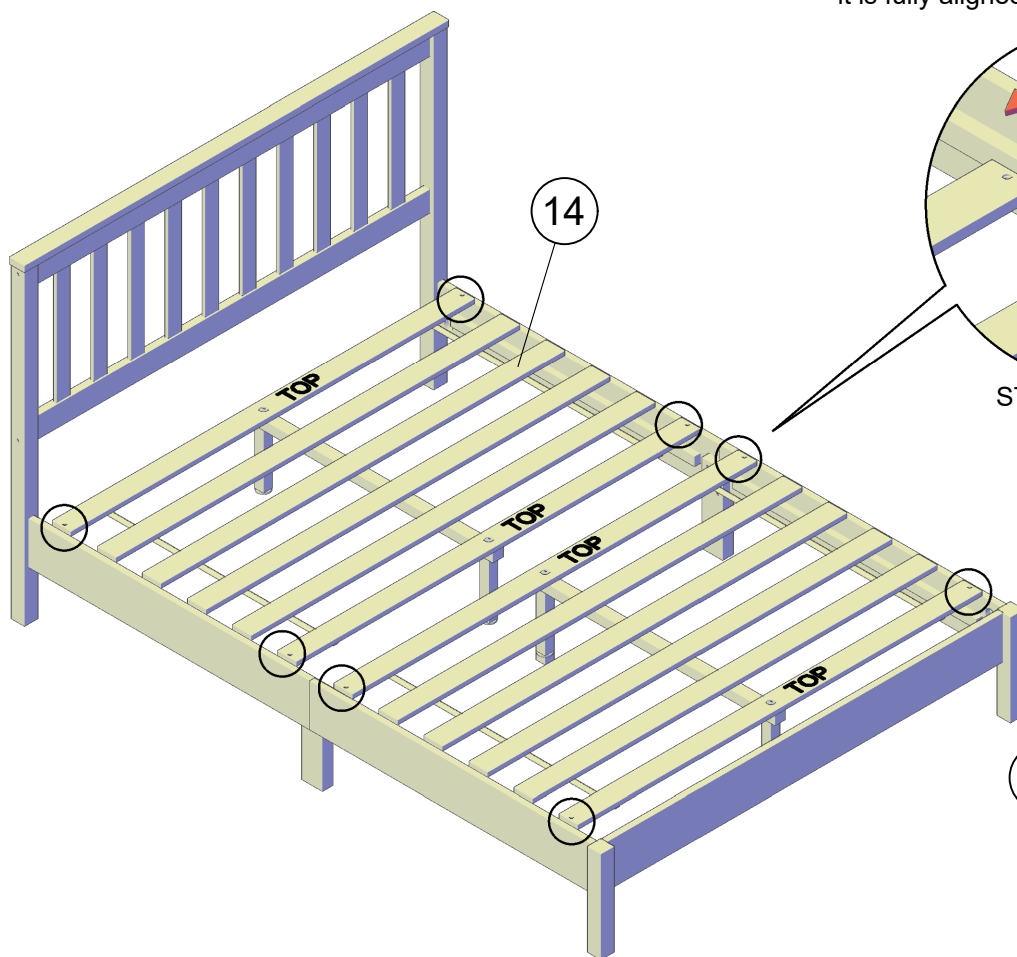

STEP 9.1

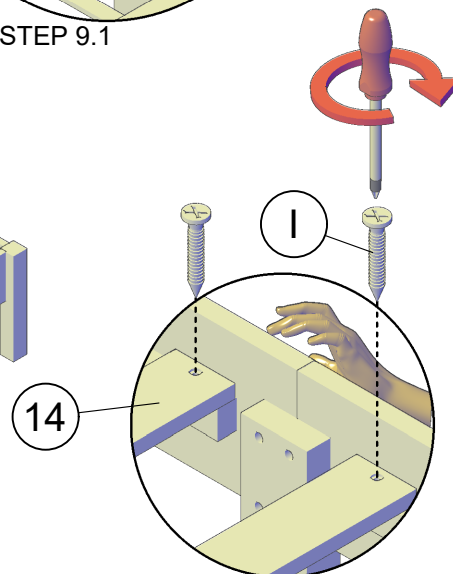

STEP 9.2

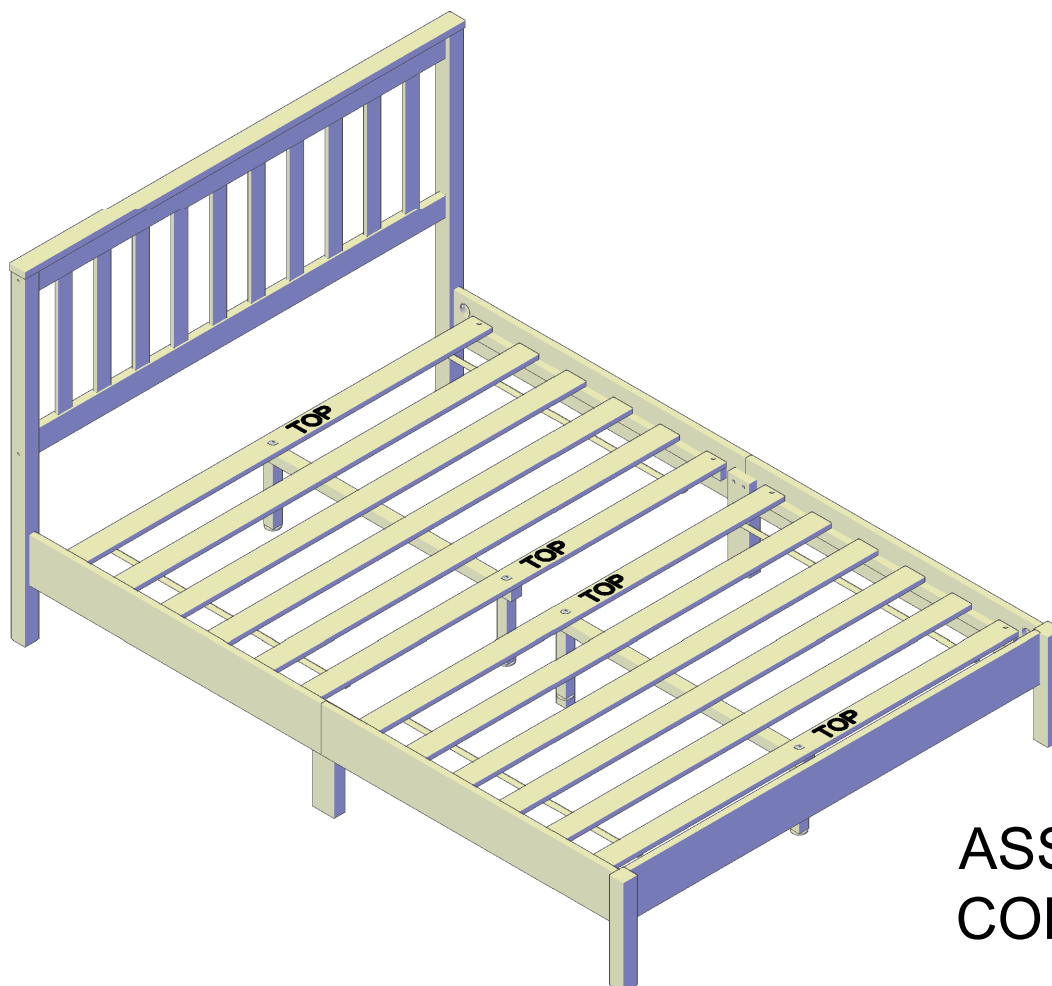

ASSEMBLY COMPLETE