

YardMaster

THE ORIGINAL No. 1

1113NG

487

DG034

Please Direct Enquires to:

Yardmaster International
Cahore Rd
Draperstown
BT45 7AP
Tel: 028 796 28449
Email: info@yardmaster.co.uk

Bitte alle Anfragen an:

I.N.I.
Kaistraße 7-9
40221 Düsseldorf
Tel: 02505 / 939027-0
Email: service@yardmaster.co.uk

Demandes De Renseignements A:

Trigano Jardin
Service Commercial
Usine du Boulay
41170 Cormenon
Mondoubleau
Tel: (02) 54 73 55 55
Fax: 02 54 73 55 61
Email: Sav.Amca@Trigano.Fr

**Assembly
Instructions**

**Instructions
D'assemblage
Abris en Métal**

**Opbouwbeschrijving
Metalen Bergingen**

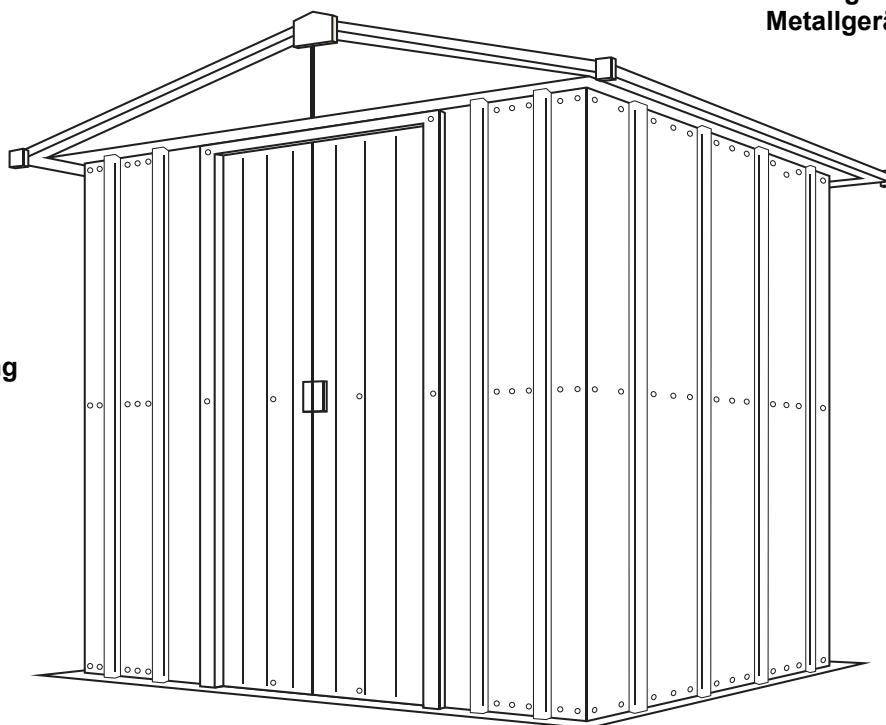

**Montageanweisungen
Metallgerätekäuser**

66 GEYZ / AEYZ

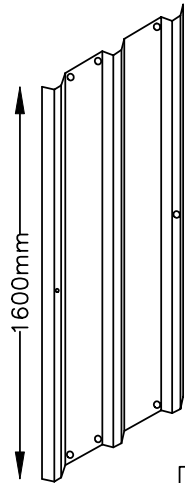
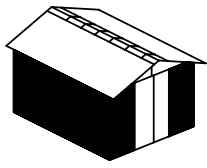

102.26 X 10

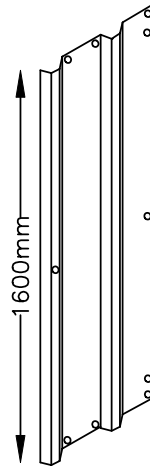

104.25 X 2

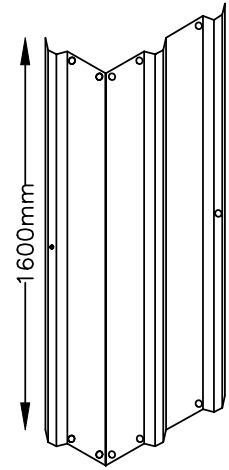

103.26 X 4

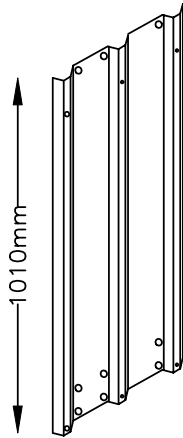
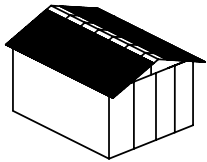

202.27 X 6

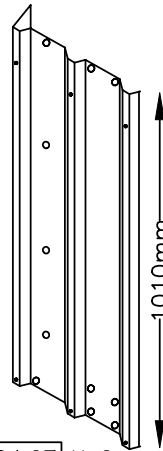

204.27 X 2

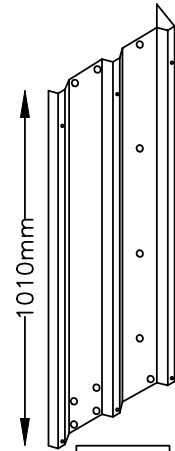

203.27 X 2

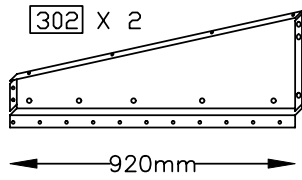
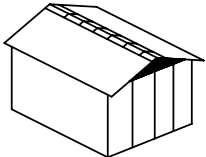

302 X 2

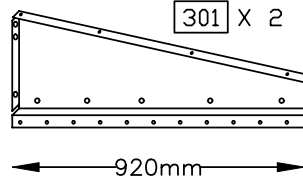

301 X 2

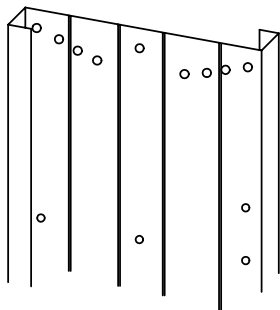
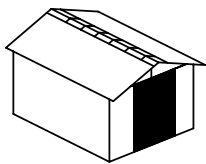
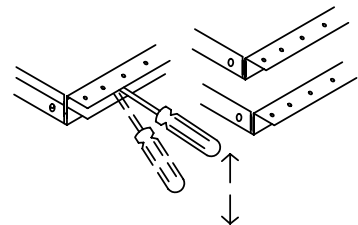

601 X 1 (1593mm)

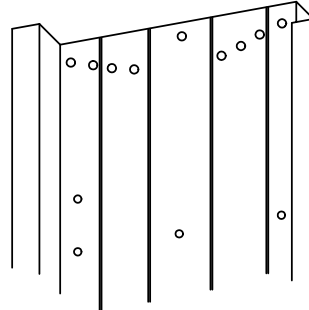

602 X 1 (1593mm)

106.03 X 2 (1600mm)

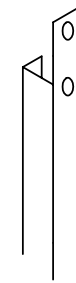

604.01 X 2 (1600mm)

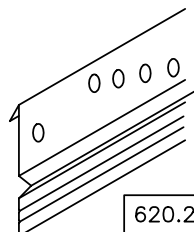
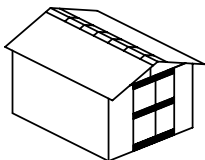

620.2 X 6 (420mm)

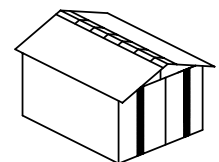

X 1790 X 1 (1790mm)

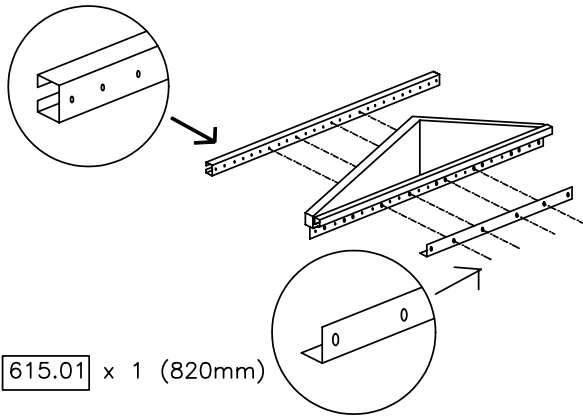

615.01 x 1 (820mm)

603.2 X 2 (1800mm)

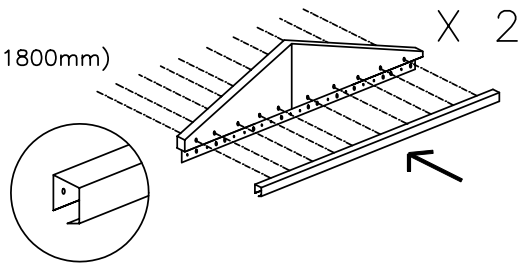

X 2

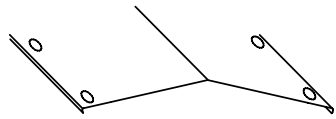

503.08 X 2 (690mm)

503.02 X 1 (615mm)

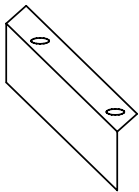
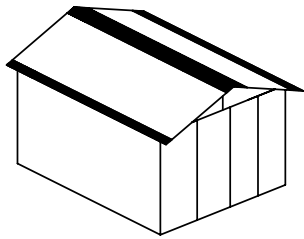

504.01 X 4 (1015mm)

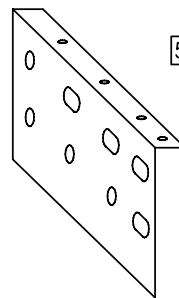

502.2 X 2 (1834mm)

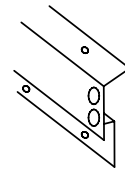
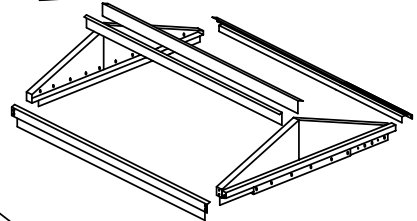

501.2 X 2 (1834mm)

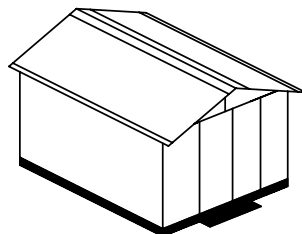

401.2 X 3 (1833mm)

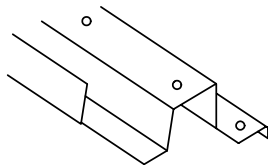
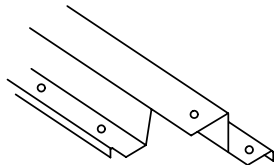

408409.2EA X 2 (634mm)

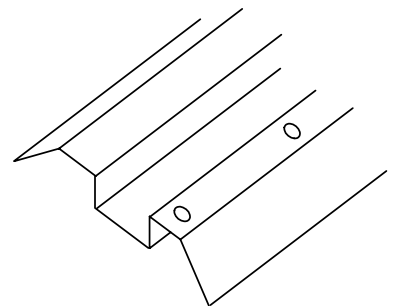

608.2EA X 1 (820mm)

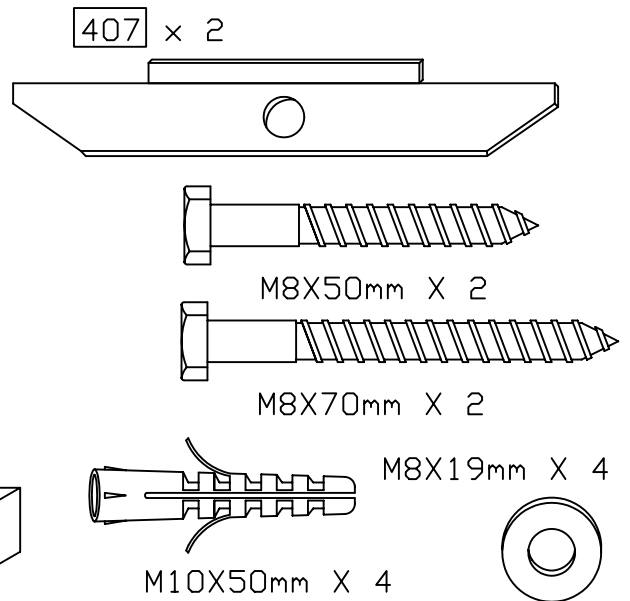
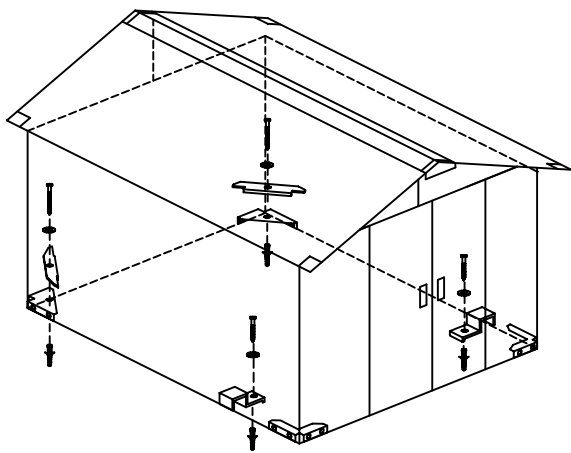
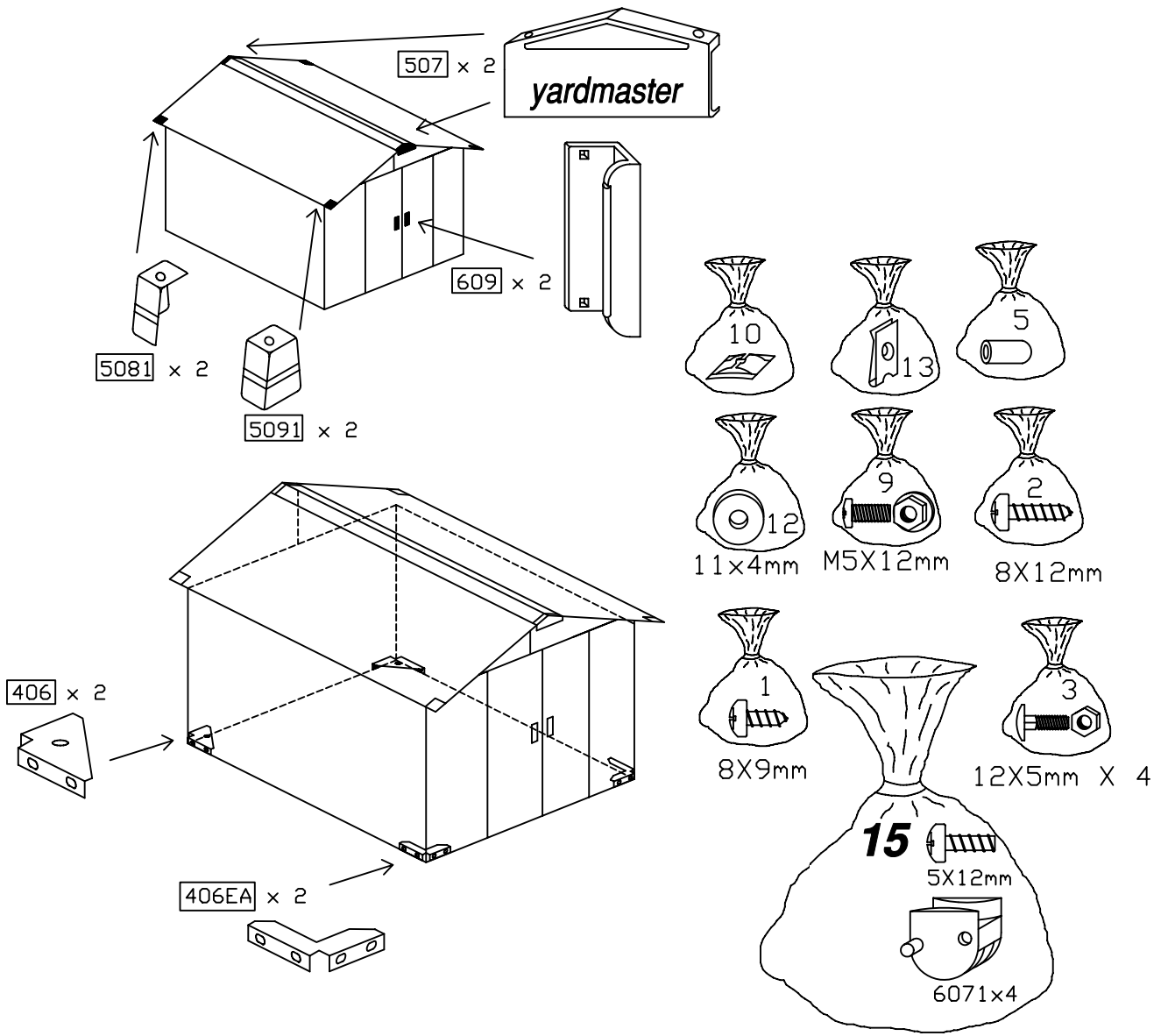

ASSEMBLY INSTRUCTIONS (ENGLISH).

Before starting, read through the assembly instructions carefully. Check thoroughly all the parts you have received against the parts list (page 1-3). Ensure that no parts are damaged.

THINGS TO REMEMBER !

- 1. WEATHER WARNING ! DO NOT ERECT YOUR BUILDING ON A WINDY DAY. ANY BUILDING LEFT PARTIALLY CONSTRUCTED MAY BE SERIOUSLY DAMAGED (FIG.1).**
- 2. ALWAYS ASSEMBLE THE ROOF FIRST STEPS 2 & 3, ESPECIALLY IF YOU DO NOT INTEND TO COMPLETE CONSTRUCTION ON THE SAME DAY.**
- 3. ALL ASSEMBLY OPERATIONS MUST TAKE PLACE ON A COMPLETELY LEVEL SURFACE (FIG. 1)**
- 4. UNLESS OTHERWISE STATED SCREWS AND FIBRE WASHERS (BAGS 1 AND 12) MUST BE USED IN ALL ASSEMBLY OPERATIONS.**
- 5. IT IS RECOMMENDED THAT YOU WEAR GLOVES WHEN ASSEMBLING THIS PRODUCT.**
- 6. THE SHED SHOULD BE SECURELY ANCHORED TO A FIRM LEVEL BASE EG CONCRETE, PAVING SLABS WOOD ETC FOR CONCRETE BASE SEE BELOW.**

SITE PREPARATION CONCRETE.

1. Concrete should be laid a minimum of 75mm thick and at least 100mm greater than the overall size of the metal base frame at approx. 25mm above ground level. A sheet of heavy duty polythene placed under the base area will help prevent dampness rising from the ground into the shed. For concrete base measurements see fig. 2.

NOTICE DE MONTAGE .

Avant de commencer à lire attentivement la notice de montage, vérifier précisément si vous avez bien reçu toutes les pièces énoncées sur la liste page 1-3, ainsi que sur le schéma page 1-3. Assurez vous qu'aucune pièce n'a été endommagée.

N'OUBLIEZ PAS !

- 1. TEMPÊTE DE VENT: NE JAMAIS MONTER VOTRE ABRI PAR GRAND VENT. NE PAS LAISSER UN ABRI PARTIELLEMENT MONTÉ, LES PIÈCES POUVANT ÊTRE ENDOMMAGÉES (FIG. 1).**
- 2. ASSEMBLER EN PRIORITÉ LE TOIT (ÉTAPE 2 ET 3) SURTOUT SI VOUS**

PENSEZ NE PAS FINIR LE MONTAGE DANS LA JOURNÉE.

- 3. TOUTES LES OPÉRATIONS DE MONTAGE DOIVENT ÊTRE RÉALISÉES SUR UNE SURFACE PLANE (fig 1).**
- 4. UTILISER SUR TOUTES LES VIS À MÉTAUX D'ASSEMBLAGE (SAC NO 1) LES RONDELLES D'ÉTANCHÉITÉ EN FIBRE (SAC NO 12).**
- 5. IL EST RECOMMANDÉ DE PORTER DES GANTS DE TRAVAIL PENDANT LE MONTAGE.**
- 6. L'ABRI DOIT ÊTRE FIXE AU SOL SUR UNE SURFACE PLANE, PAR EXEMPLE, BÉTON, DALLES EN BÉTON, BOIS ETC. POUR UNE SURFACE DE BÉTON, VOIR CI-DESSUS.**

PRÉPARATION DE LA DALLE:

1. Le béton doit être coulé sur une épaisseur de 75mm, et dépasser de 100mm la hauteur du profilé de base soit 25mm au dessus du niveau du sol. L'utilisation d'une toile de polythène épaisse et résistante, placée sous la base aidera à empêcher l'humidité de monter du sol dans l'abri. Pour les dimensions de la dalle en béton, vous reporter à la fig. 2.

MONTAGEANLEITUNG

VOR BEGINN:

1. Machen Sie sich mit den Montageanweisungen vertraut.
2. Überzeugen Sie sich an Hand der Teilleiste (Seite 1-3) und der Schaubilder (seite 1-3), ob alles vollzählig ist und die Teile nicht beschädigt sind.

WICHTIG

- 1. STELLEN SIE DAS HAUS NICHT AN EINEM STÜRMISCHEN TAG AUF. JEDES HAUS WÜRDE UNTER SOLCHEN WETTER-BEDINGUNGEN BESCHÄDIGT WORDEN.**
- 2. DER GARTENSCHUPPEN MUß AUF EINER VOLLSTÄNDIG EBENEN FLÄCHE ERRICHTET WERDEN.**
- 3. SOFERN NICHT ANDERS ANGEZEIGT BENÜTZEN SIE DIE SCHRAUBEN UND WASSERDICHTEN FASERSCHEIBEN (BEUTEL 1 & 12) BEI ALLEN MONTAGEGÄNGEN.**
- 4. TRAGEN SIE DIE BELIEFERTEN HANDSCHUHE BEI DER MONTAGE.**
- 5. ES WIRD EMPFOHLEN, HANDSCHUHE BEI DER MONTAGE ZU TRAGEN.**

6. DAS HAUS MUß AUF EINER FESTEN EBENEN FLÄCHE VERANKERT WERDEN, Z.B. AUF BETON, BETONPLATTEN, HOLZ. BEI BETONFLÄCHEN SEHEN SIE UNTEN.

VORBEREITUNG DES BETONFUNDAMENTS:

Die Betonplattform soll mindestens 70-80mm stark und mindestens 100mm länger und breiter als der metall-grundrahmen sein. die plattform sollte außerdem mindestens 25mm über dem boden sein.

Ein laken aus hochleistungskunststoff unter dem fundament wird dazu helfen, feuchtigkeit vorzubeugen, die von der erde in den schuppen hineindringt.

BOUWHANDLEIDING

Voordat U met de bouw begint, maakt U zich dan eerst goed vertrouwd met de bouwaanwijzingen. Kruis alle ontvangen onderdelen op de onderdelenlijst (pagina 1-3) en diagram (pagina 1-3) aan. Controleer of de onderdelen niet zijn beschadigd.

BELANGRIJK !

- 1 MONTEER UW SCHUUR NIET OP EEN WINDERIGE DAG. DE KANS DAT ER TÏDENS HET MONTEREN BESCHADIGINGEN ONTSTAAN IS DAN ZEER GROOT AANWEZIG (Afb 1).**
- 2 HET IS AAN TE RADEN , OM EERST HET DAK TE MONTEREN, STAP 2 & 3 VOORAL ALS U NIET VAN PLAN BENT OM HET COMPLETE SCHUURTJE IN EIN DAG TE MONTEREN.**
- 3 DE BOUW DIENT UITGEVOERD TE WORDEN OP EEN GEHEEL VLAKKE ONDERGROND (Afb 1)**
- 4 TENZY ANDERS AANGEGEVEN MOETEN BIJ HET MONTEREN DE SCHROEVEN EN VEZELRINGEN UIT (Zak 1 en 12) WORDEN GEBR UIKT.**

5. HET IS AAN TE RADEN HANDSCHOENEN BIJ HET MONTEREN TE DRAGEN.

VOORBEREIDING VAN DE BOUWPLAATS VAN BETON

1 Het beton dient minimaal 75mm dik te worden gelegd. Ongeveer 25mm boven grondniveau dient het beton minstens 100mm breder te zijn dan de totale maal van het metalen funderingsraam.
Afb. 2.

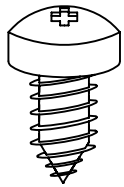

WASHERS TO BE USED ON ALL SCREWS
 VEZELRINGEN VOOR GEBRUIK ONDER ALLE SCHROEVEN
 RONDELLES POUR TOUTES LES VIS
 FASER SCHEIBEN FÜR VERWENDUNG MIT ALLEN SCHRAUBEN
 ARANDELAS QUE DEBEN USARSE CON TODOS LOS TORNILLOS
 ANILHAS PARA SEREM UTILIZADAS EM TODOSMOS PARAFUSOS

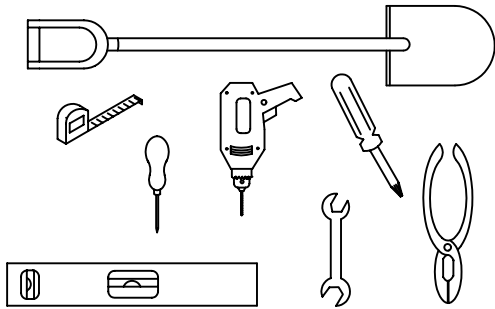
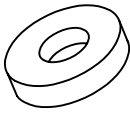
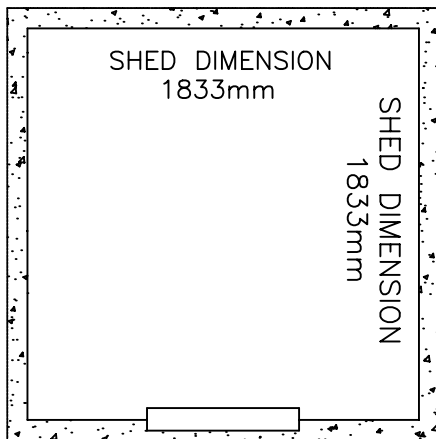

FIG. 2

FIG. 1



BASE DIMENSION
2000mm



FRONT DEVANT FREITE
 VOORKANT VORDERSEITE

STEP/ETAPE 1

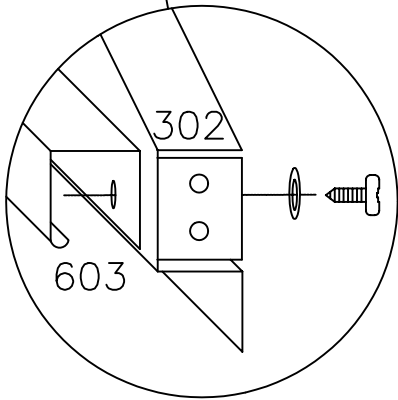
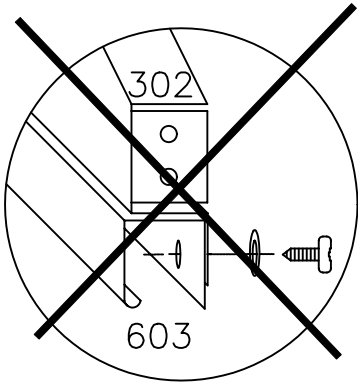
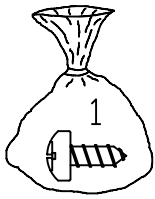
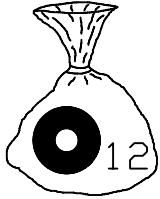
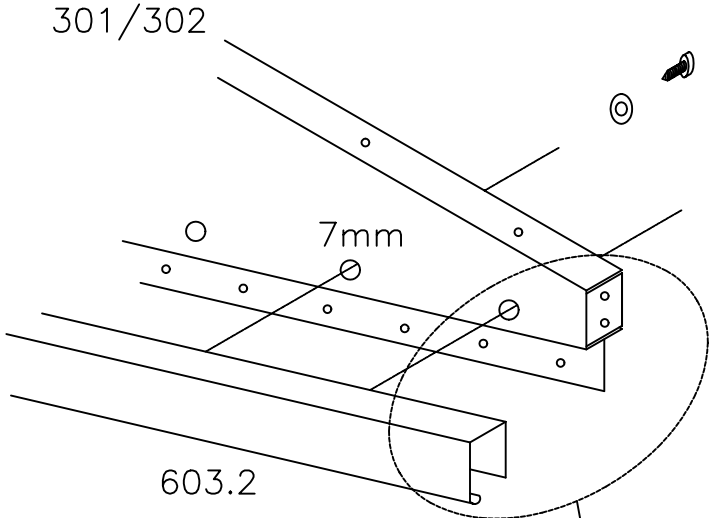
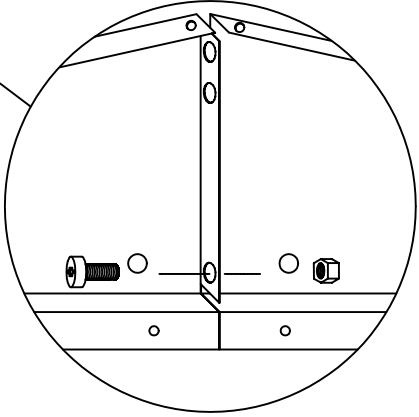
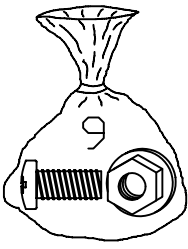
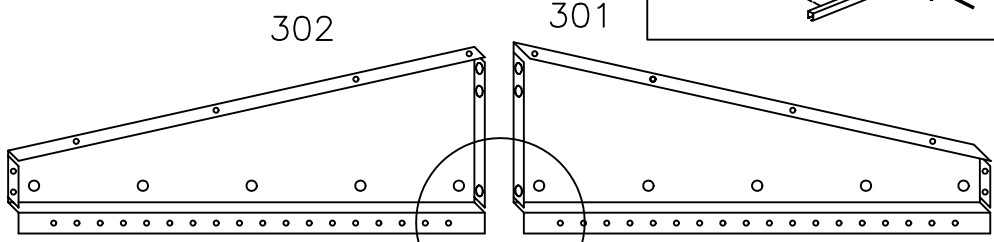
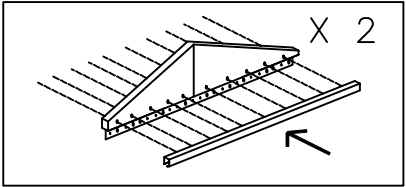

7mm Holes / Trou

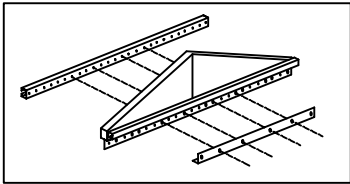

302

301

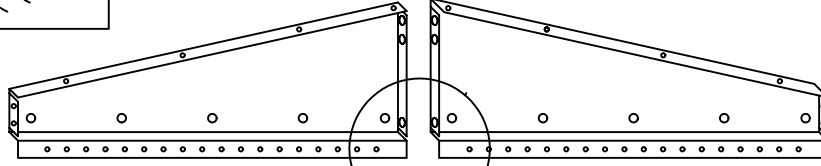

FRONT GABLES
PIGNON-AVANT

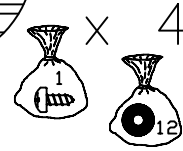
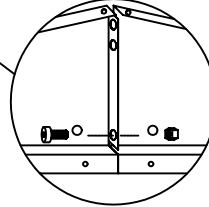

X 4

302

615

301

603.2

X 1790

X 1790

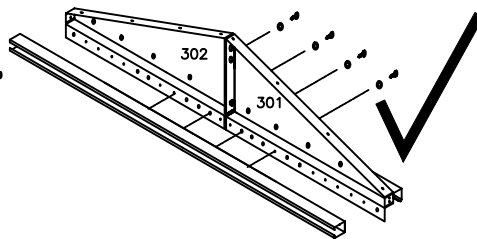
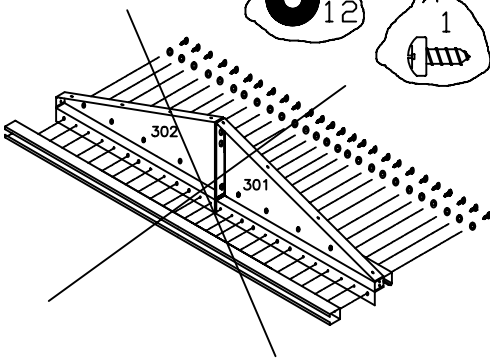
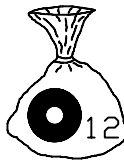
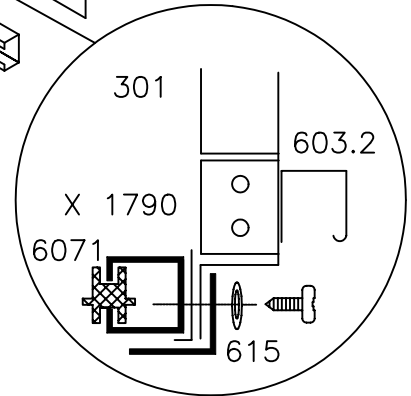
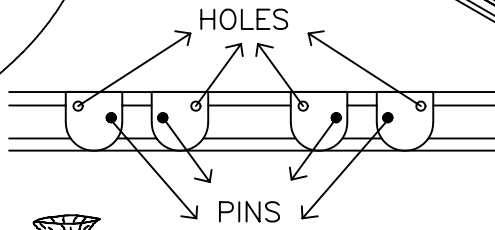
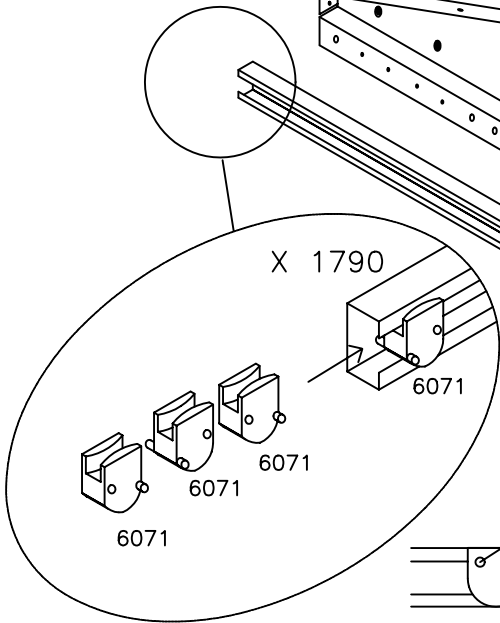

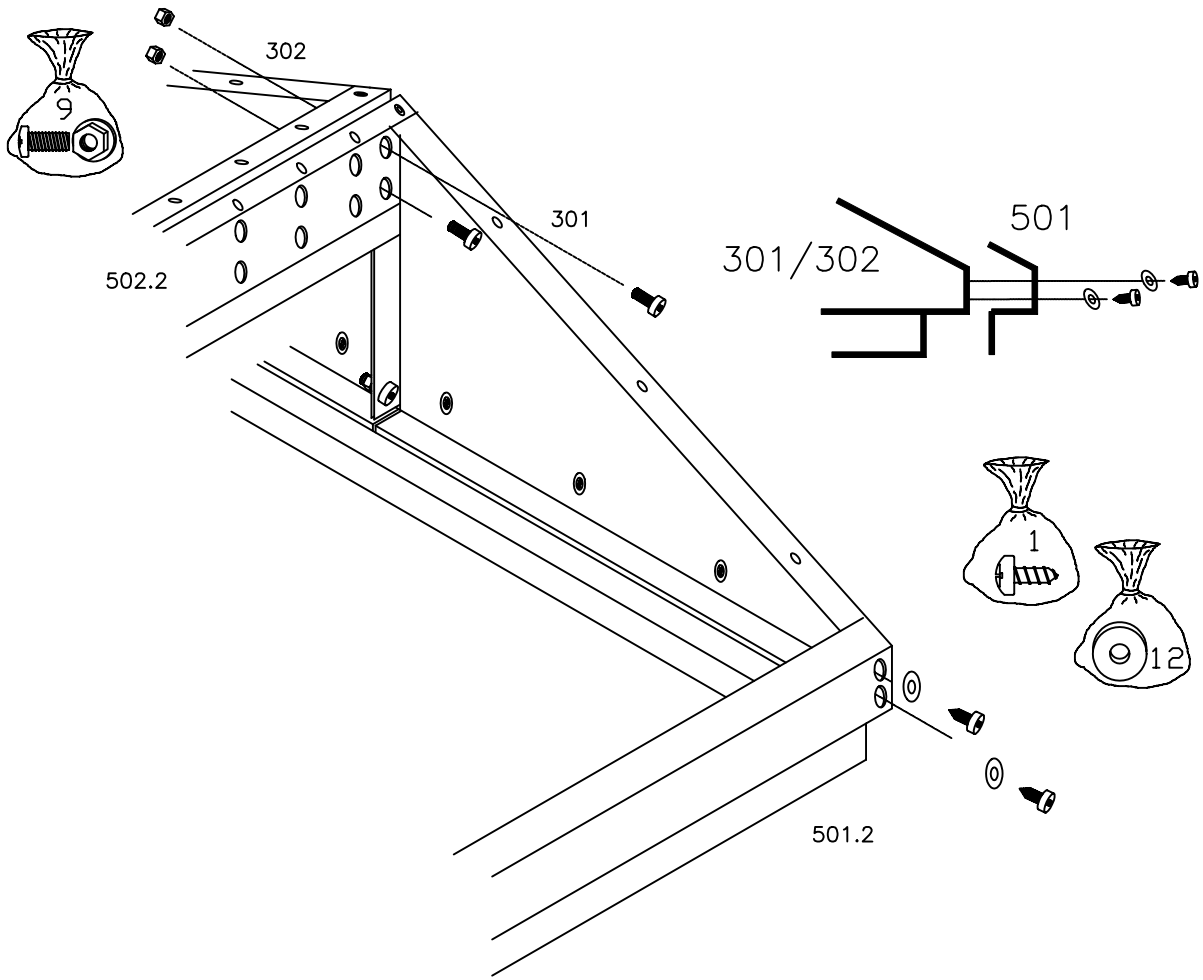
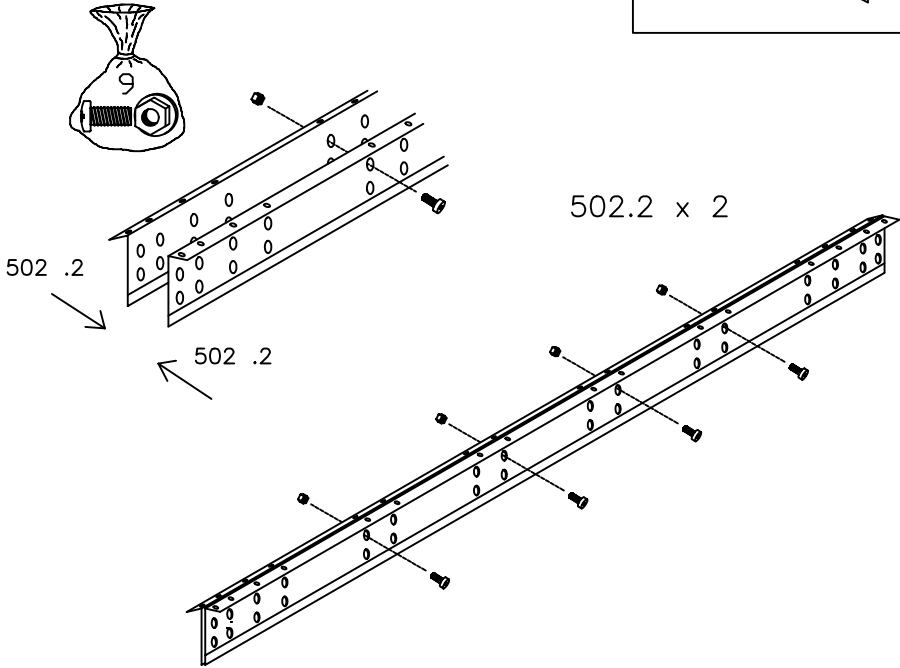
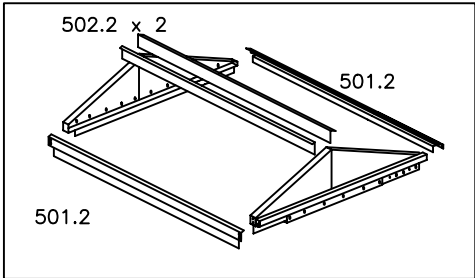

STEP/ETAPE 2

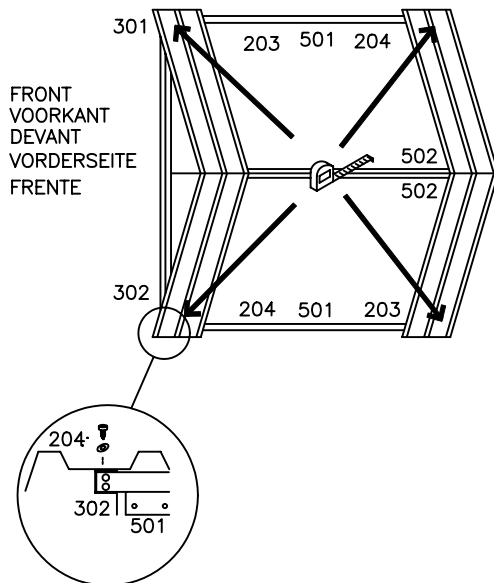
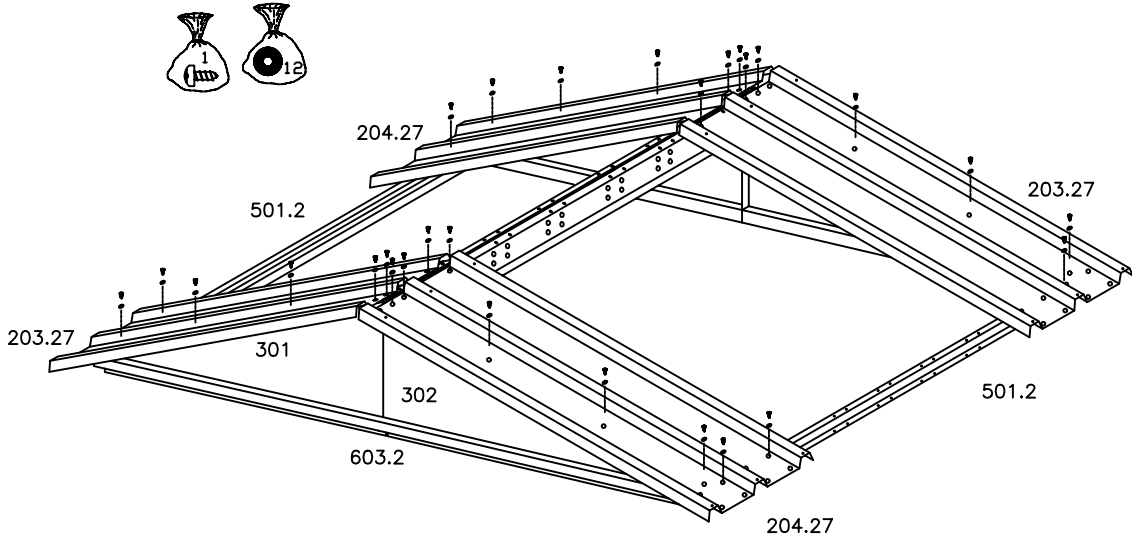
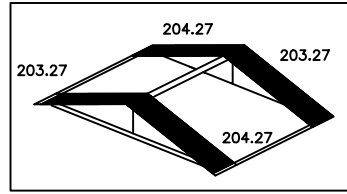

FRONT
VOORKANT
DEVANT
VORDERSEITE
FRENTE

ENSURE ROOF FRAME
IS "SQUARE" BEFORE
SECURING PANELS

DACHRAHMEN RECHTWINKLIG
VOR DACHPLATTEN
FESTZUMACHEN

EQUARREZ LE METIER
AVANT DE FIXER
LES PANNEAUX

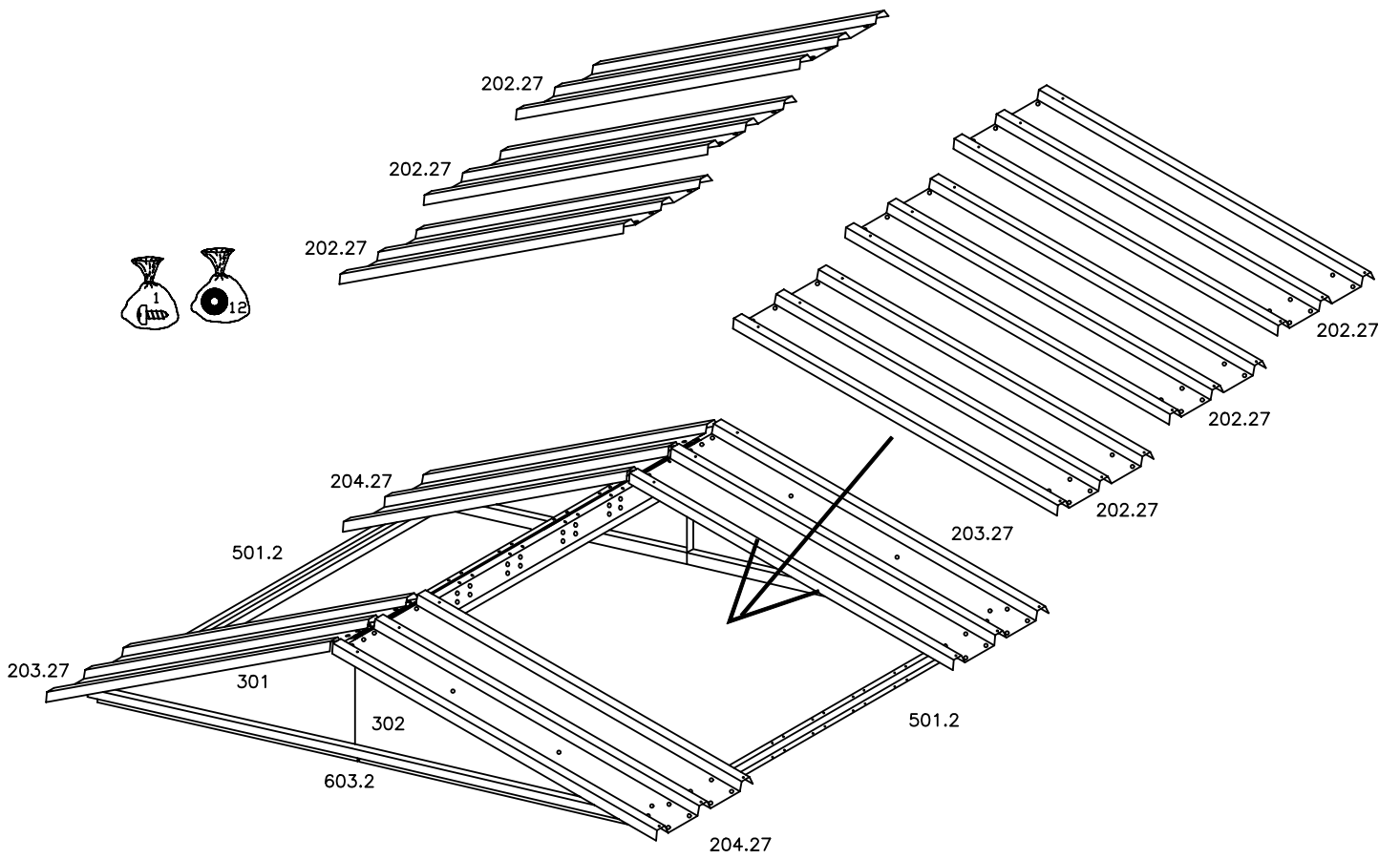
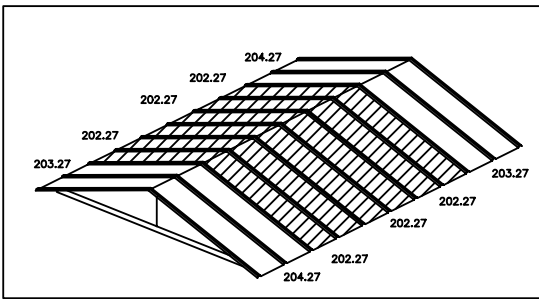

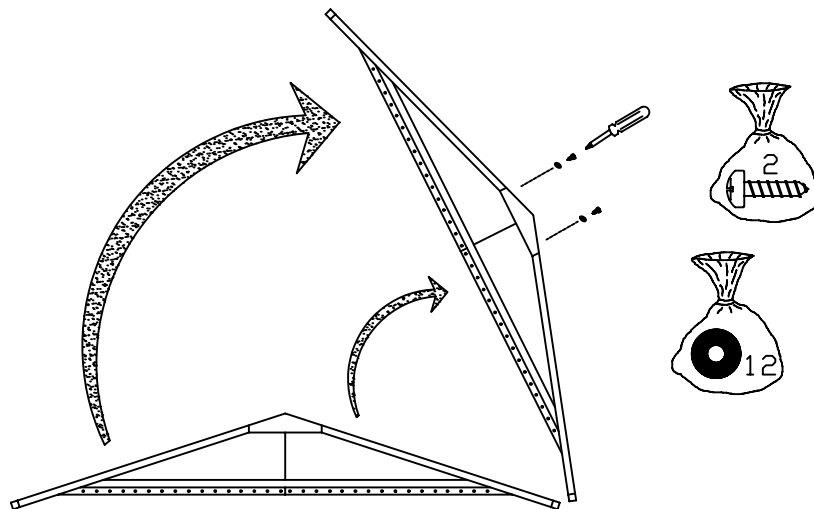
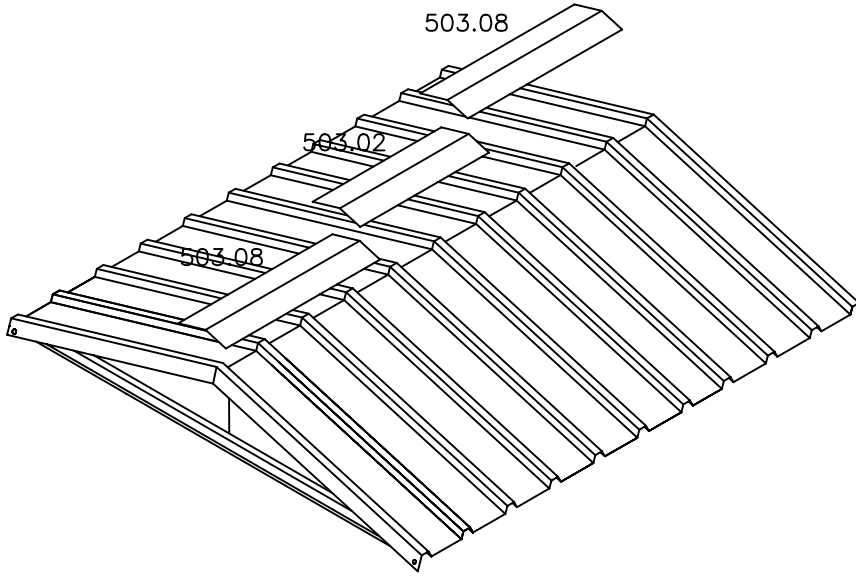
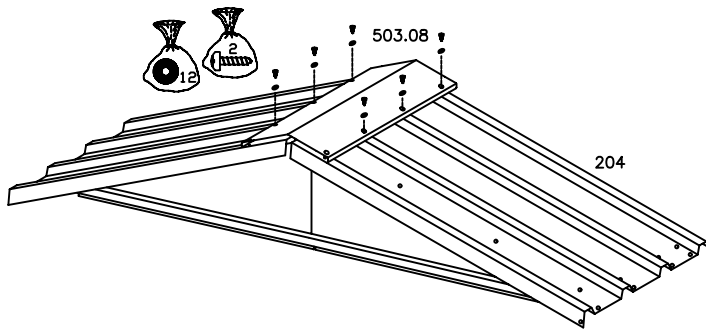

STEP/ETAPE 3

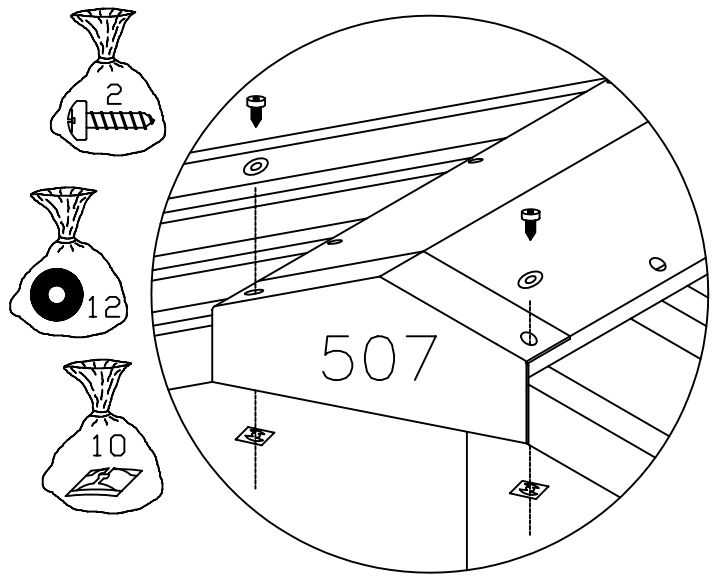
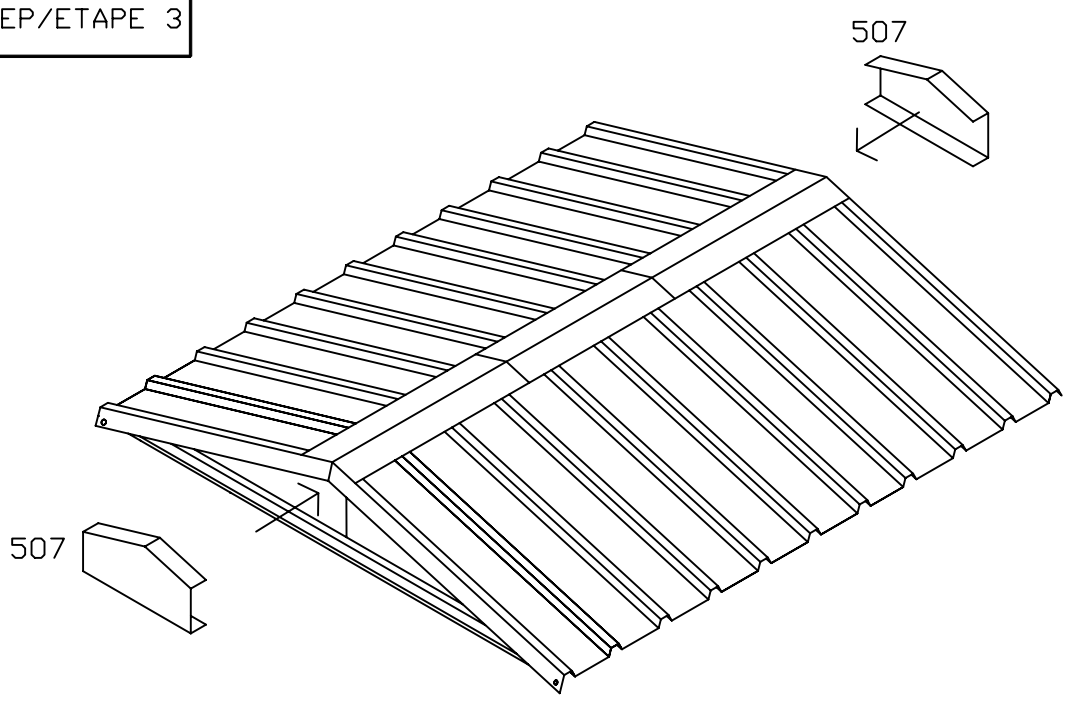

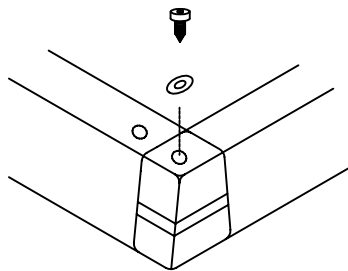
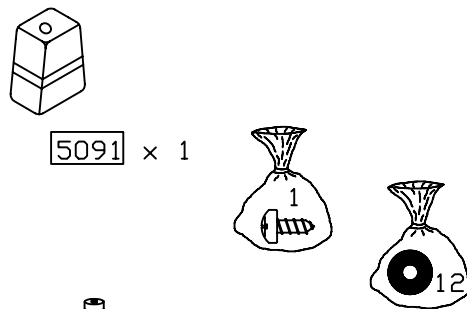
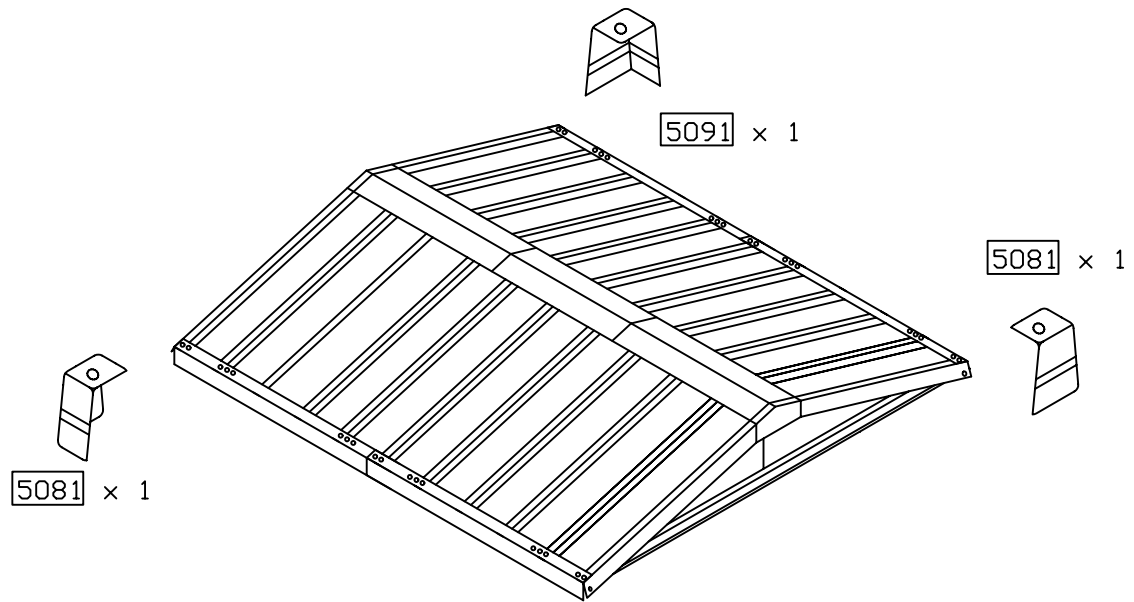
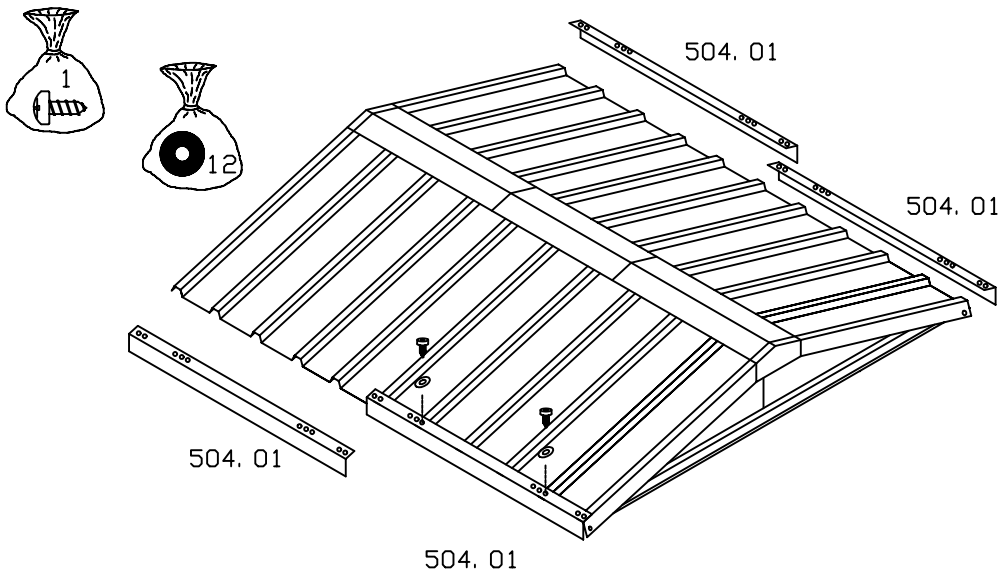

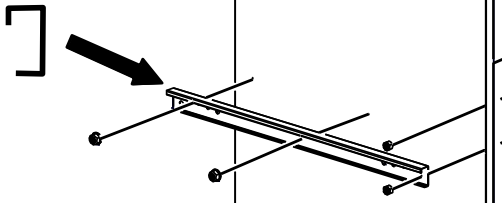
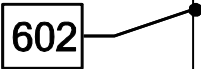
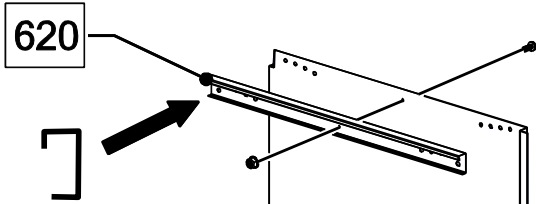
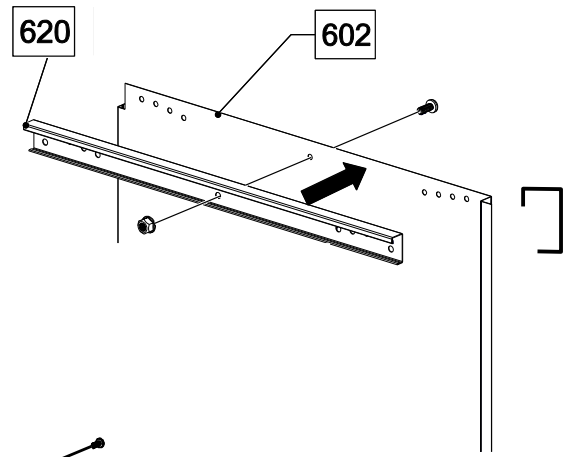
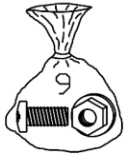

INSIDE
A L'INTERIEUR
INNENSEITE

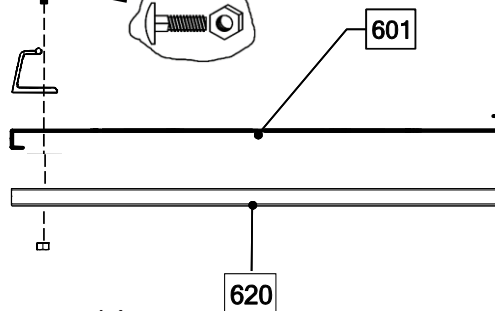
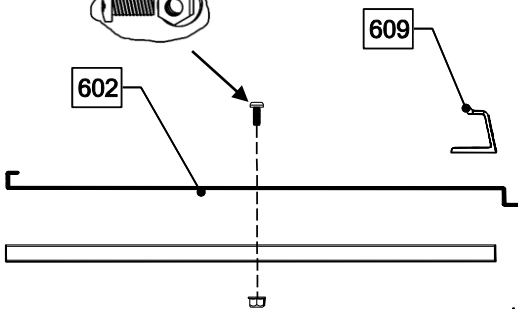
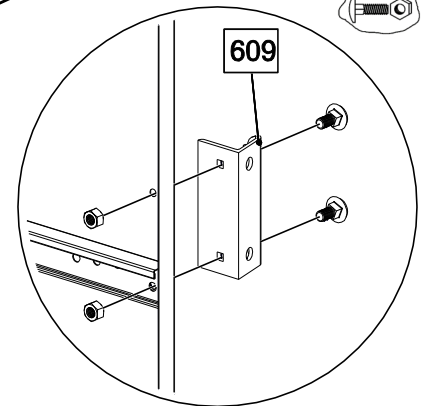
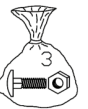
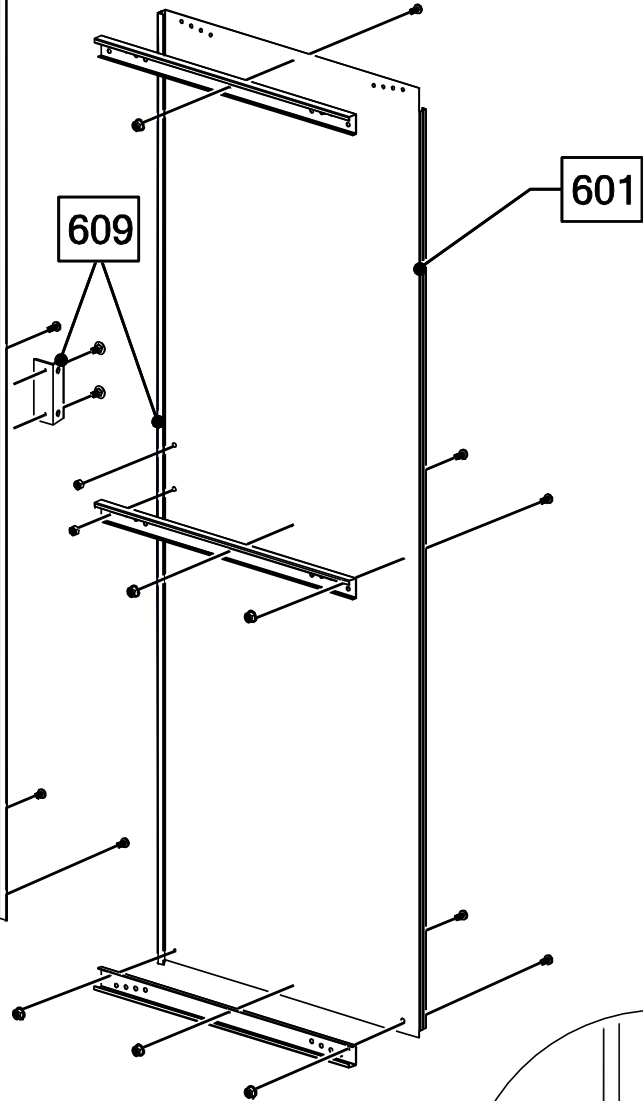
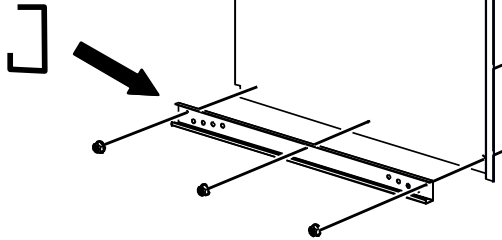

INSIDE
A L'INTERIEUR
INNENSEITE

STEP/ETAPE 5

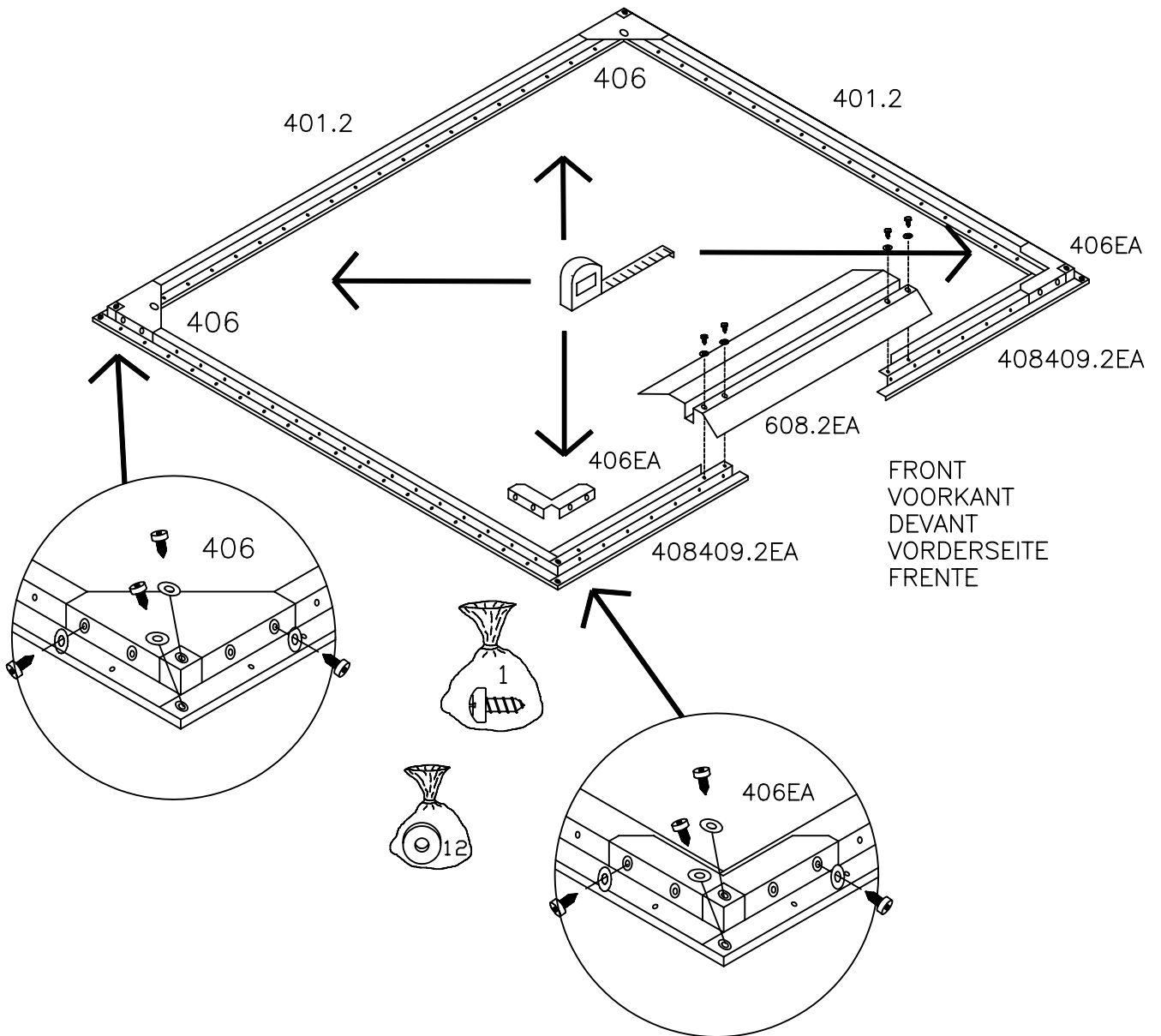
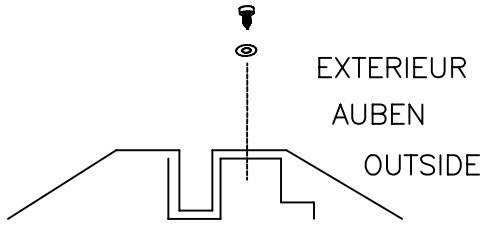

STEP/ETAPE 6

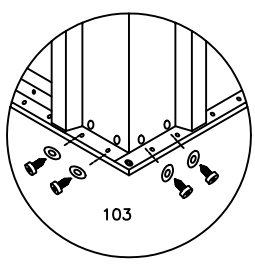
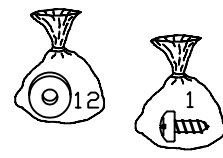
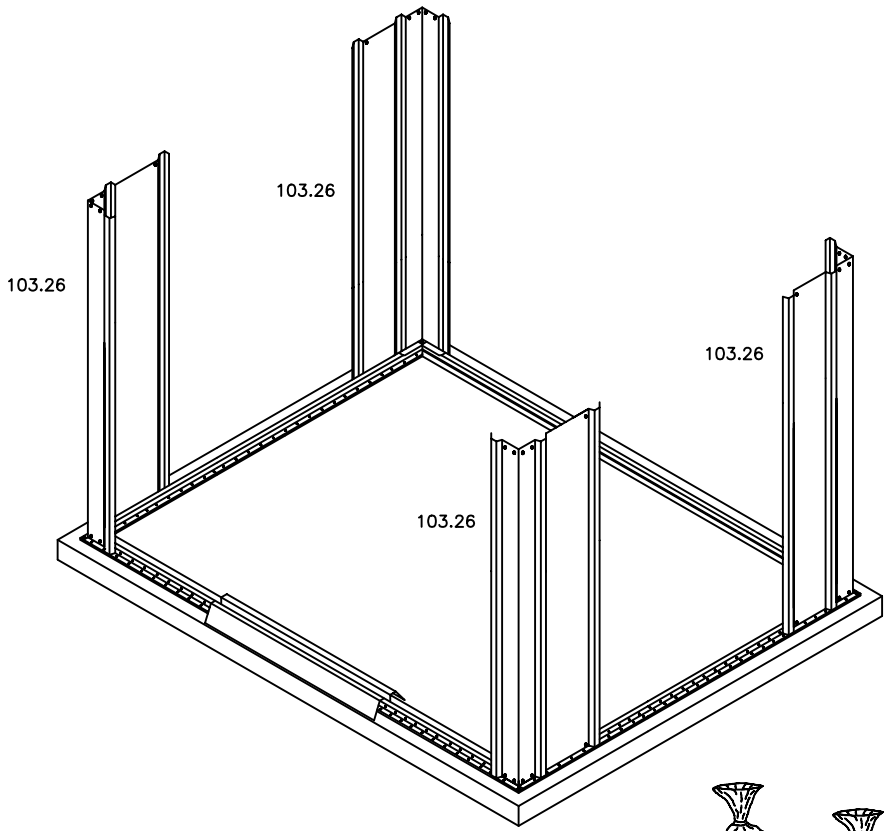
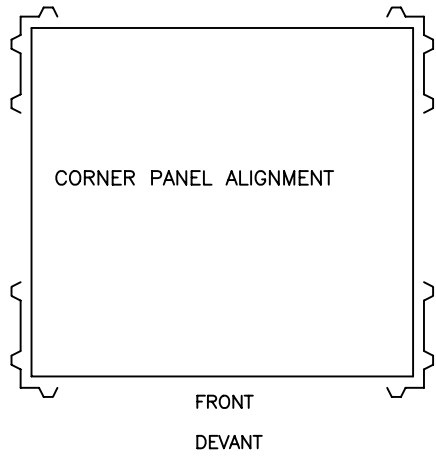

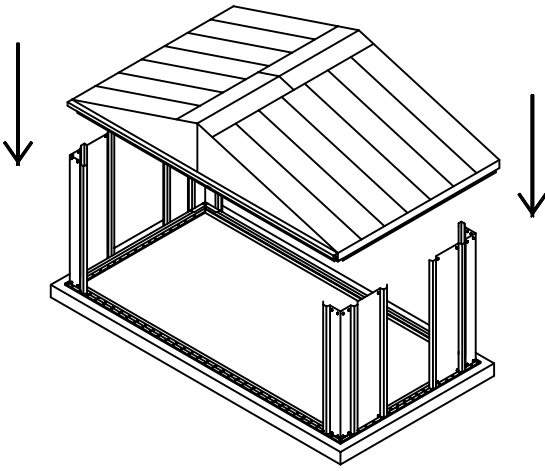

LIFT ROOF ONTO WALLS AND SECURE

LEVER LE TOIT SUR LES MURS
ET FIXER SECUREMENT

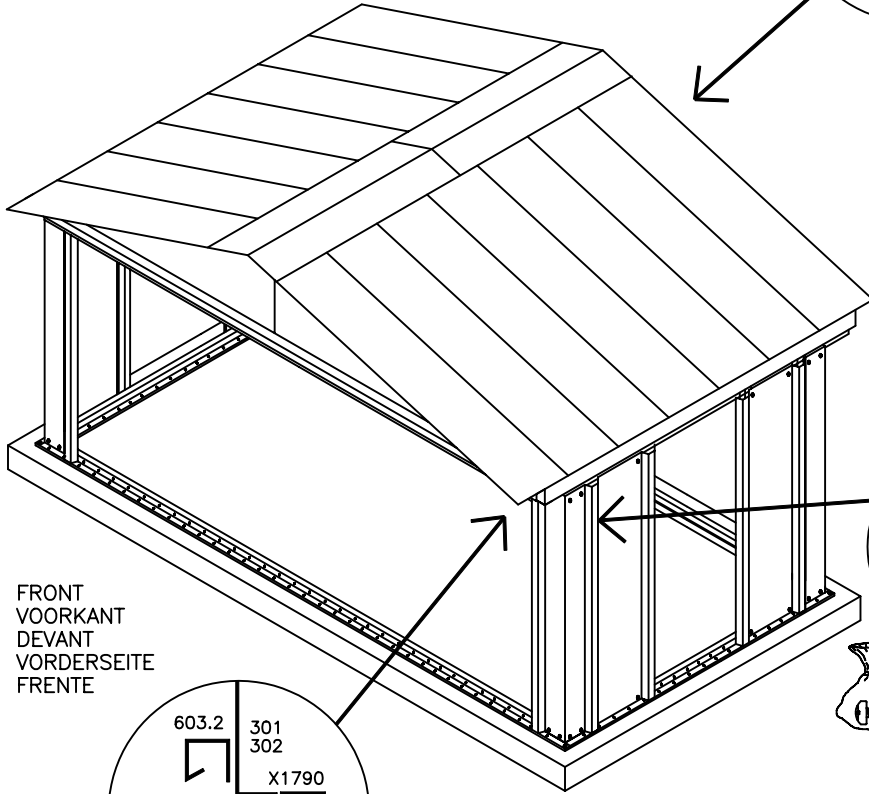
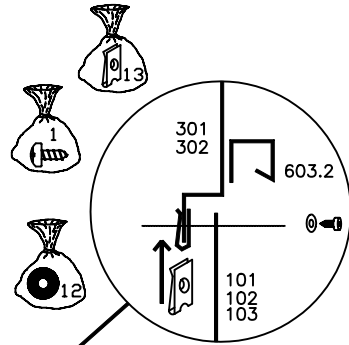

FRONT
VOORKANT
DEVANT
VORDERSEITE
FRENTE

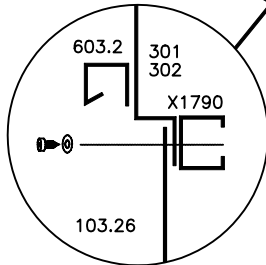

Attach Wall Panels 102.26 to Sides and Back

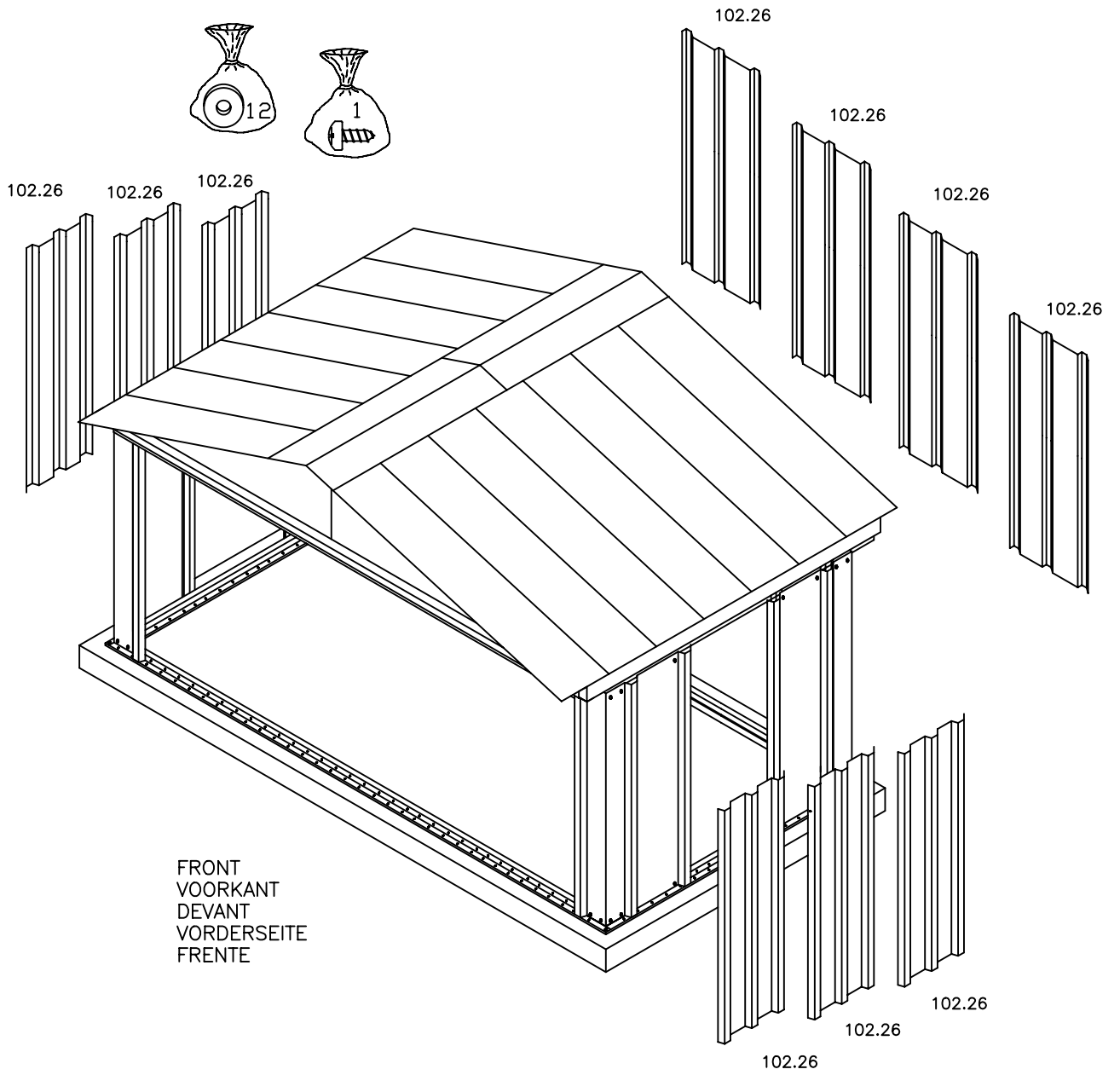

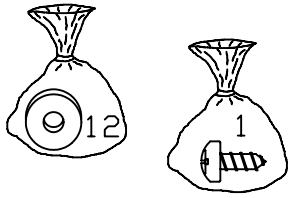

WALL PANEL ASSEMBLY
MONTEREN VAN WANDPANEEL
MONTAGE DE LA PANNEAU MURAL
WANDPLATTEN MONTAGE
PAINEL DA PAREDE
PANELES DE LA PARED

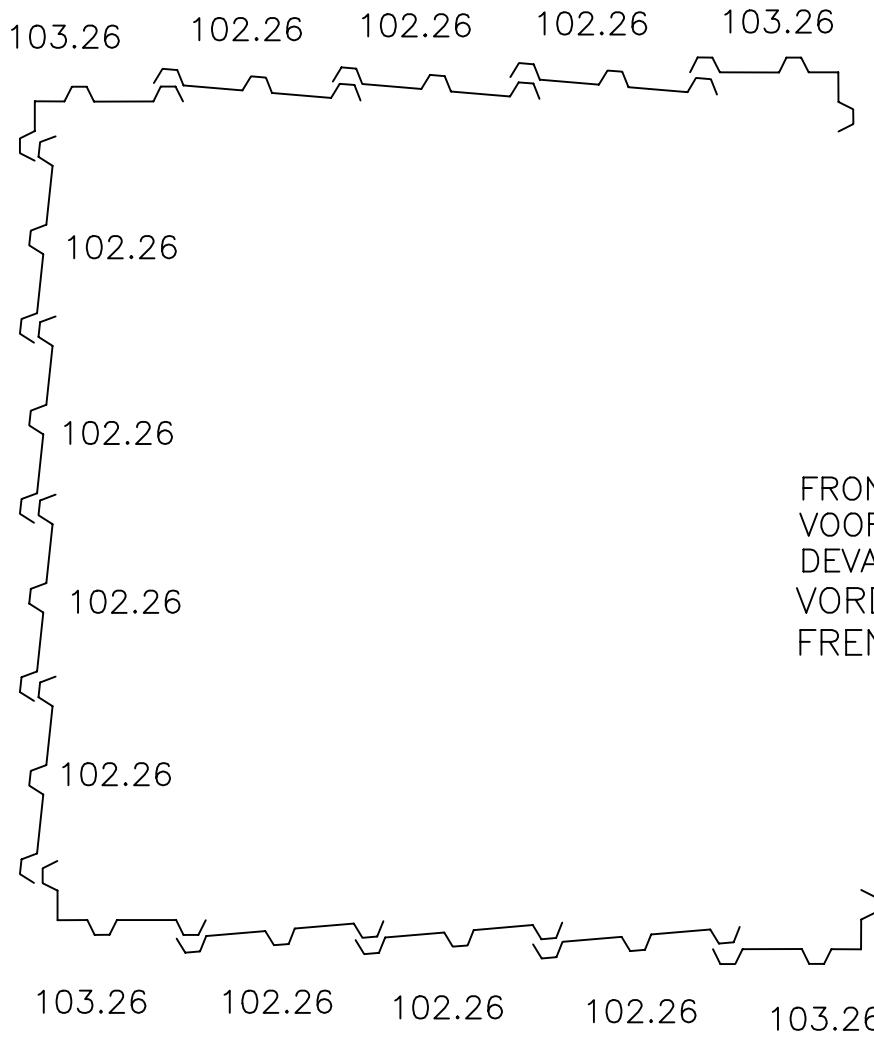

FRONT
VOORKANT
DEVANT
VORDERSEITE
FRENTE

STEP/ETAPE 7

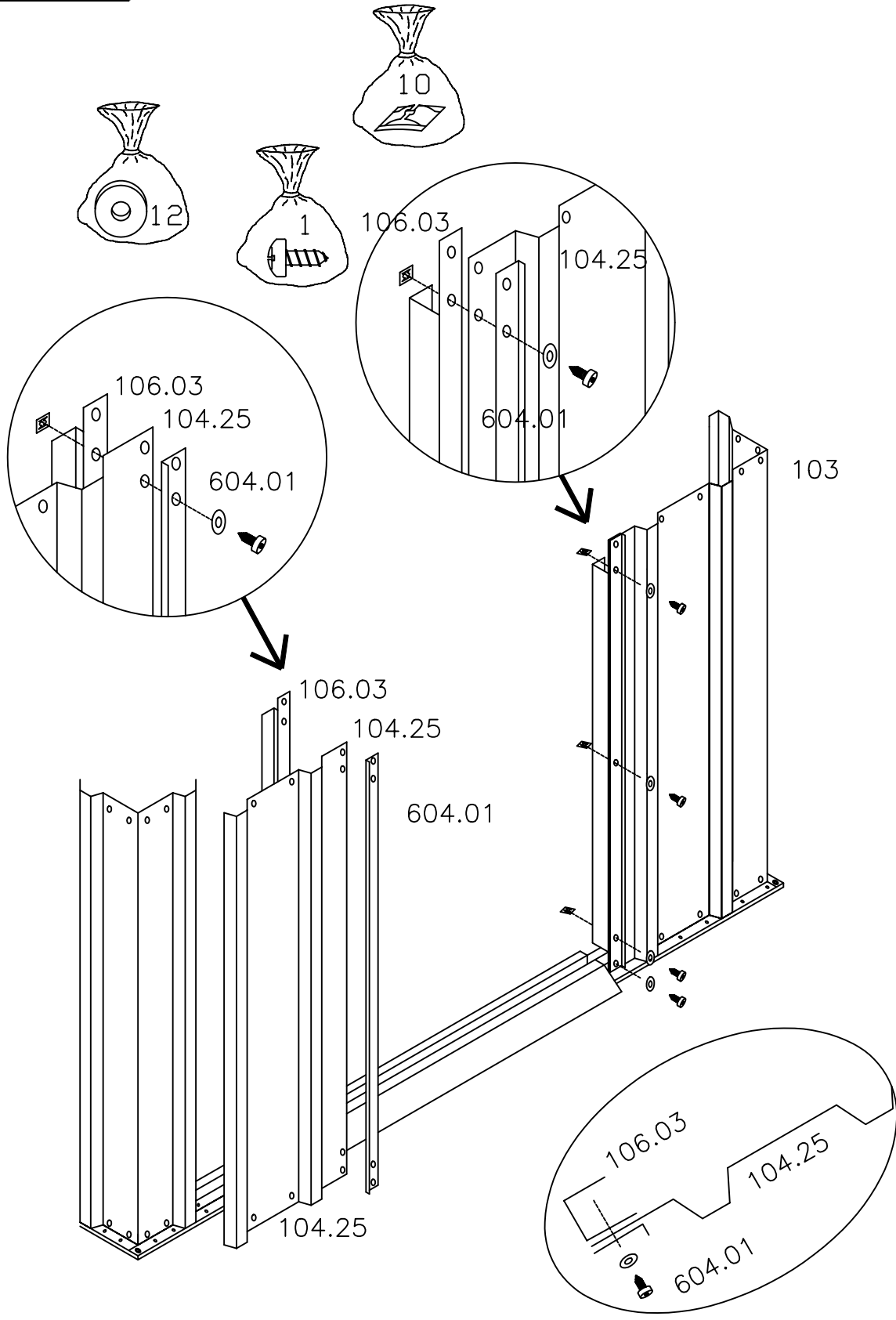

STEP/ETAPE 8

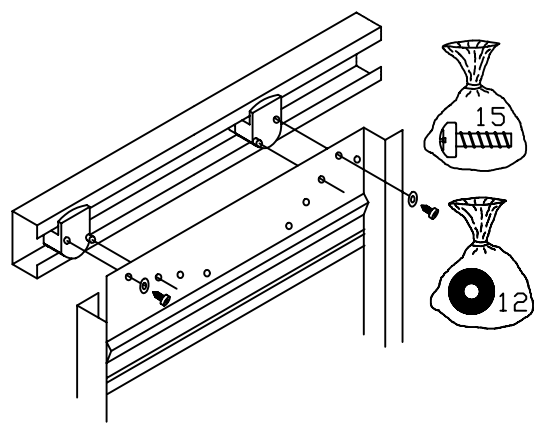
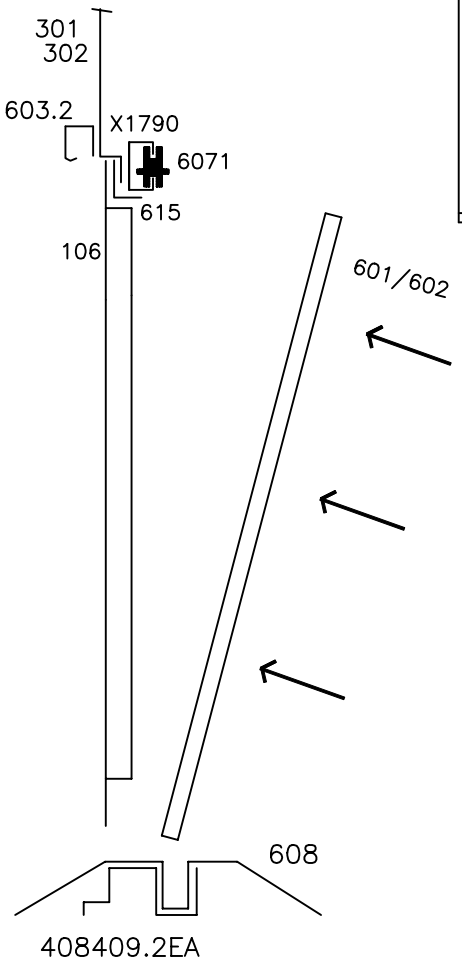
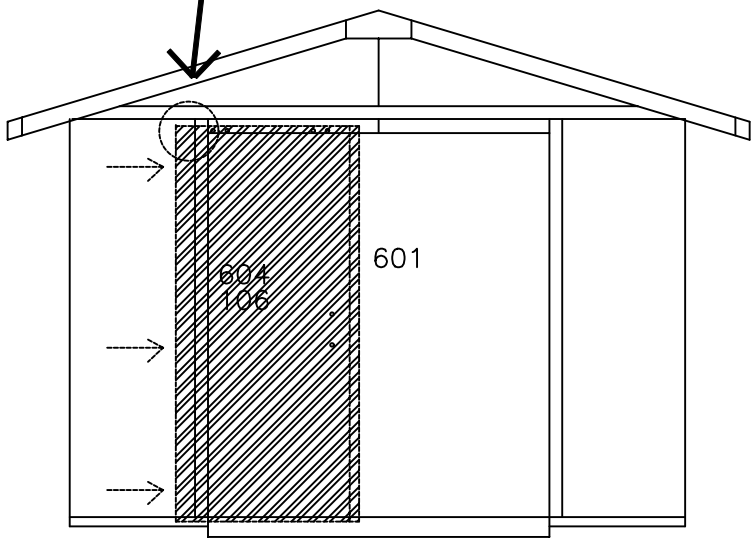
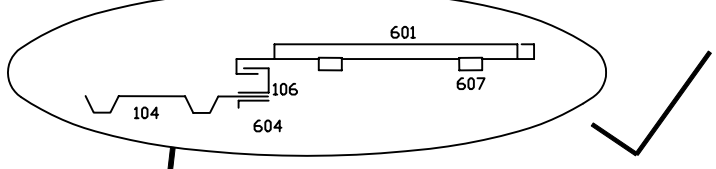
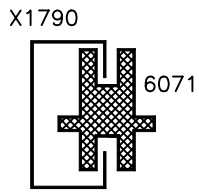
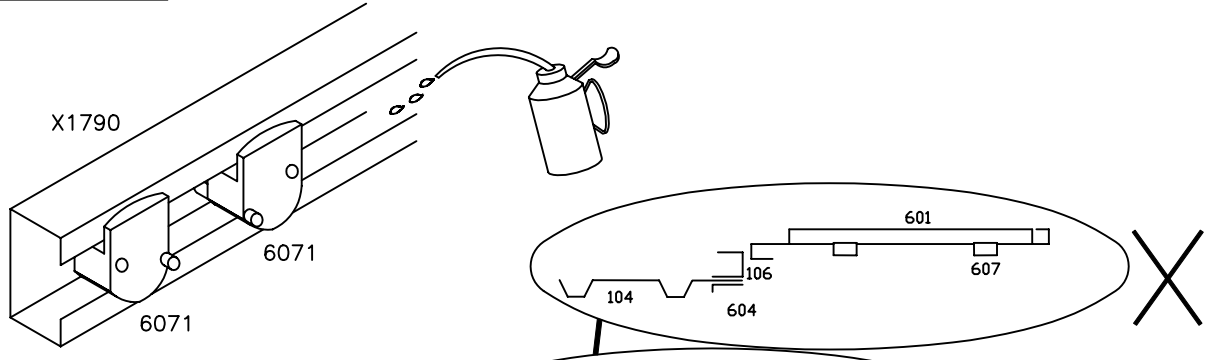

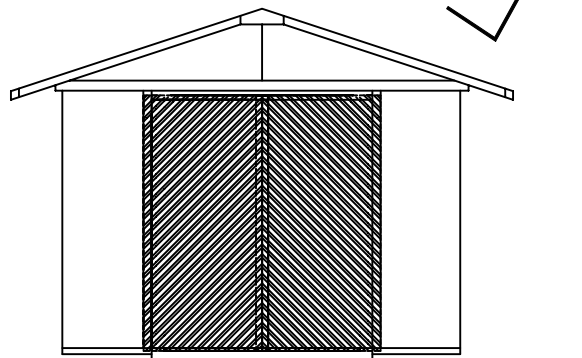
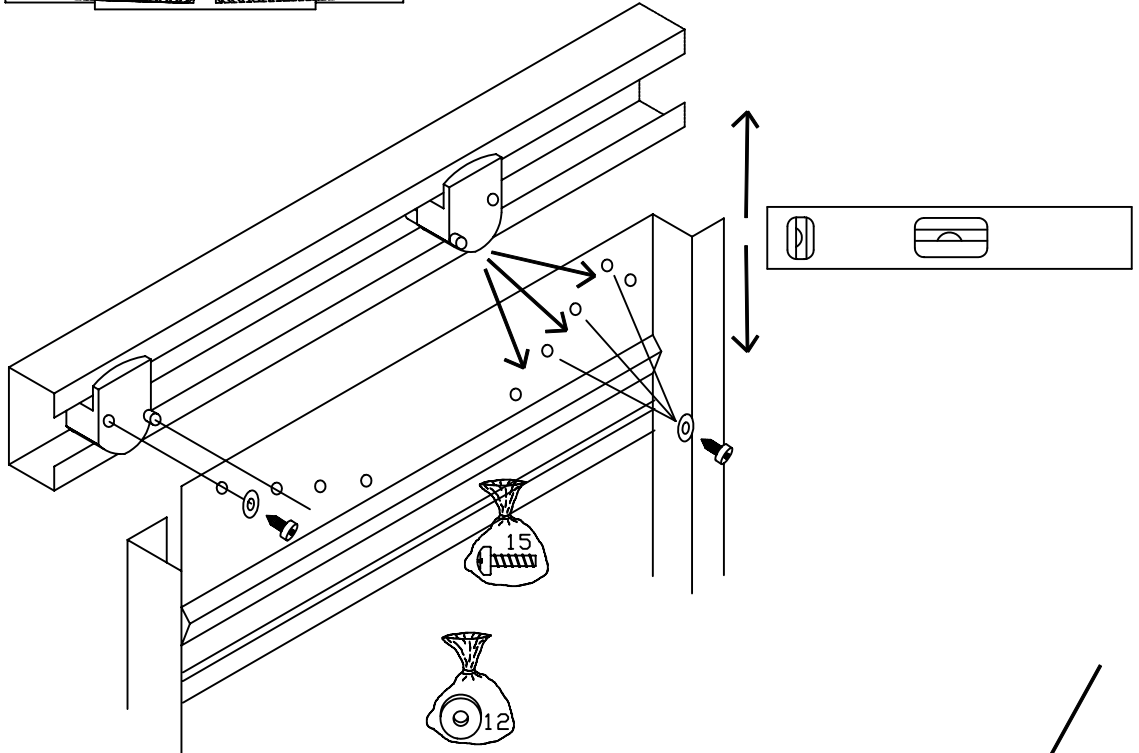
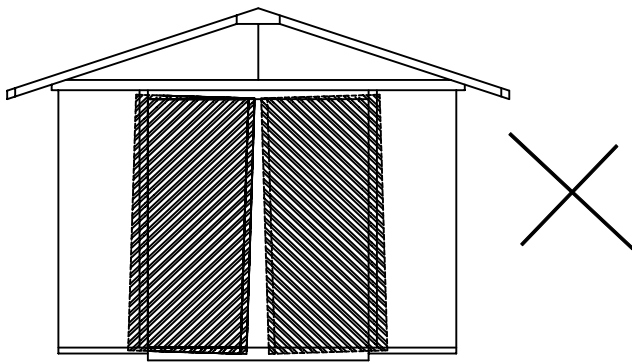

STEP/ETAPE 9

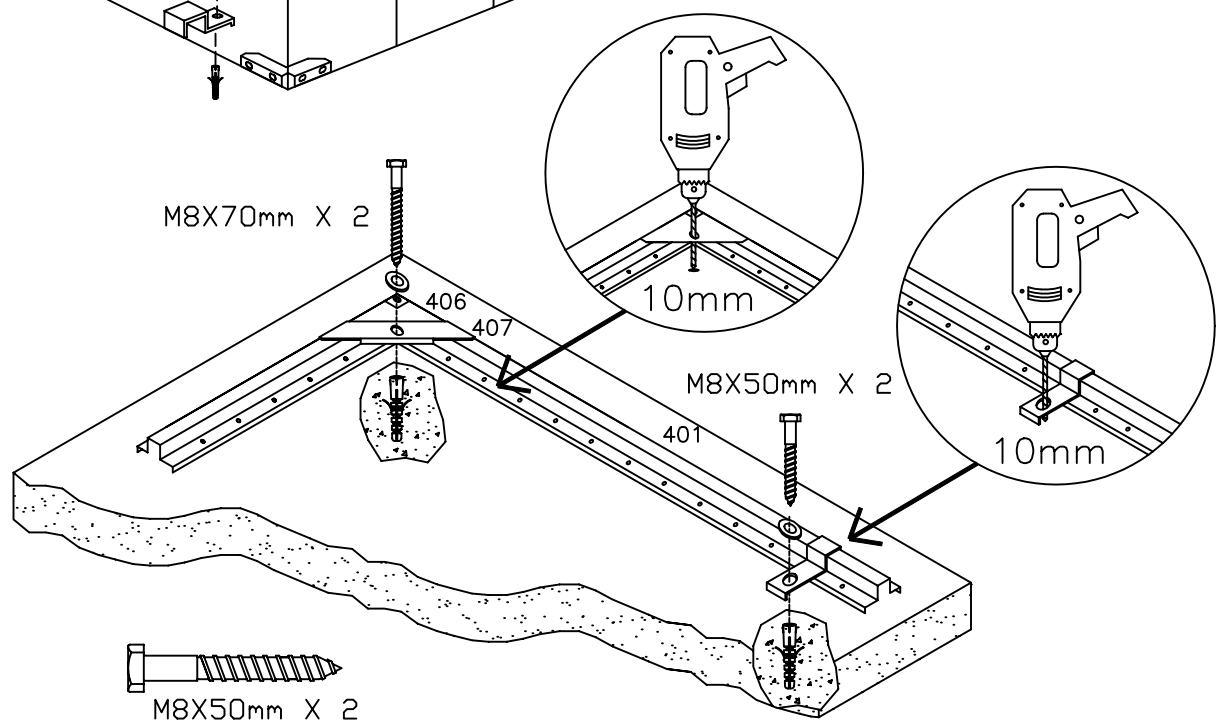
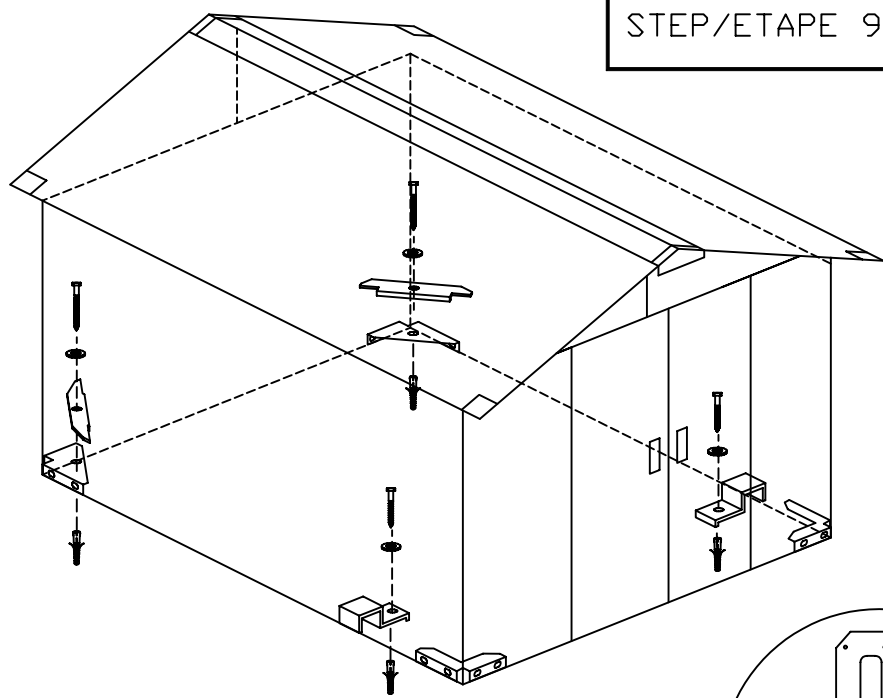

- M8X70mm X 2
- M8X50mm X 2
- M10X50mm X 4
- M8X70mm X 2
- M8X19mm X 4
- 407 x 2
- 5

BAG NO. 5 PLASTIC TIPS USED ON EXPOSED SCREW POINTS
ON INSIDE WALLS
SAC NO. 5 CAPUCHONS EN PLASTIQUE POUR POINTES DE VIS
NUES SUR LES PAROIS INTERIEURES