

# ASSEMBLY INSTRUCTIONS

NO.	HARDWARE LIST	QTY
A	 M6x10 mm	8pcs
NO.	PART LIST	QTY
B		2pcs
C		1pc

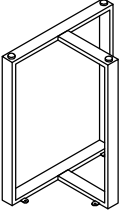
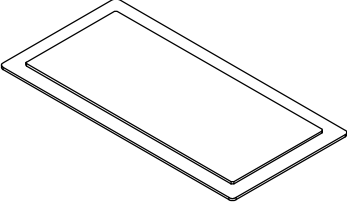
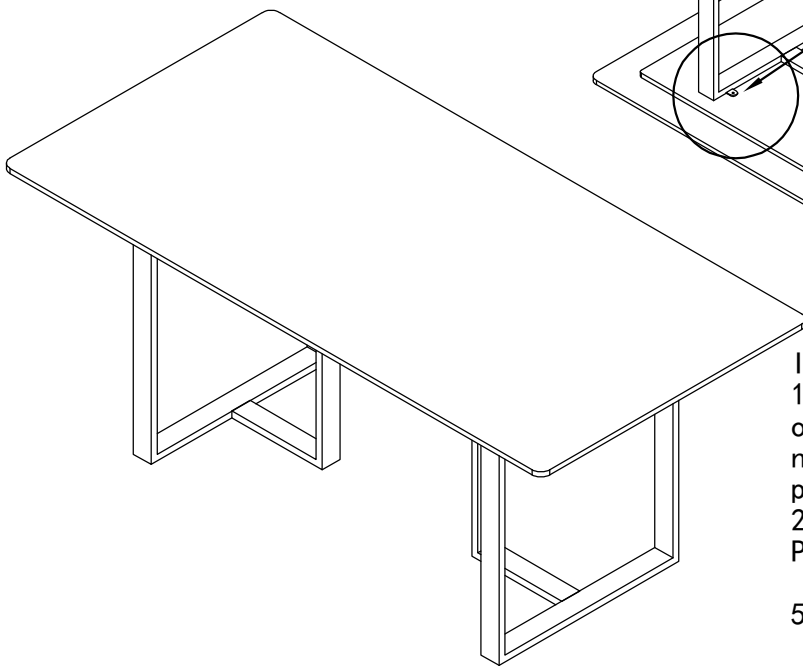
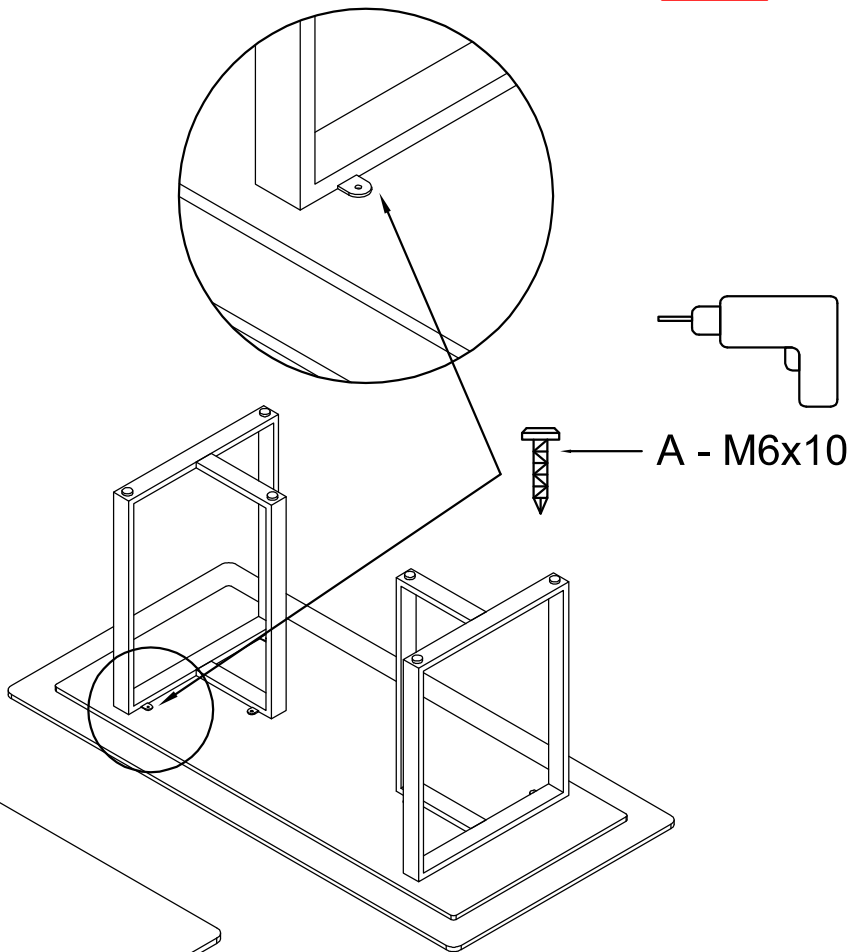
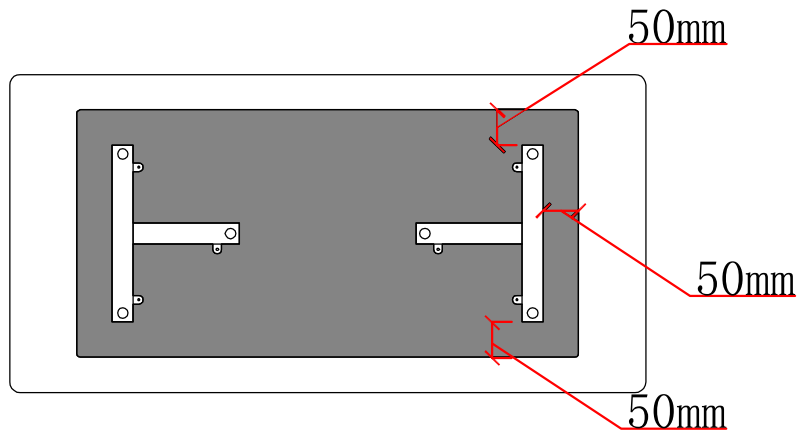

## Installation Steps:

1. Horizontally place dining table top side down on the ground. (Note that the top surface should not be directly touched with the ground, you can put a piece of cloth underneath)
2. Take out the support frame and begin installing. Place the support frame like it is in the illustration, when both ends of the frame are 50mm (or 1.97 inches) away from the edge of the board, use a power tool or a manual screwdriver to fix the self-tapping screws.
3. Turn the dining table side up. There you are a lovely perfect dining table.