

ASSEMBLY INSTRUCTIONS INSTRUCTIONS DE MONTAGE

N717P417963

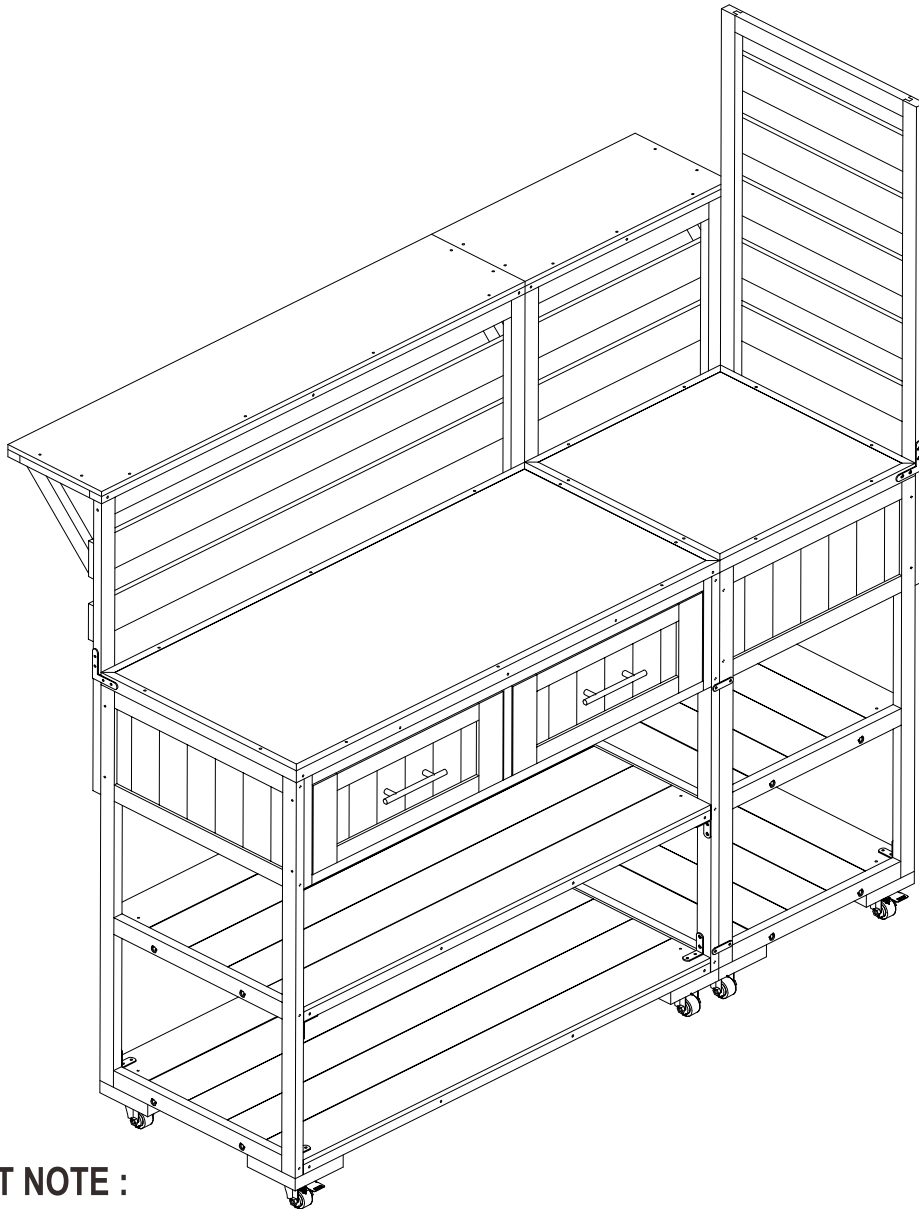

IMPORTANT NOTE :

- ① PLACE ALL PARTS ON A CLEAN AND SMOOTH SURFACE SUCH AS A RUG OR CARPET TO AVOID THE PARTS FROM BEING SCRATCHED.
- ② BEFORE YOU BEGIN, KINDLY FOLLOW THE ASSEMBLY INSTRUCTIONS STEP BY STEP.
- ③ DO NOT TIGHTEN ALL SCREWS AND BOLTS UNTIL THIS ITEM IS FULLY SET-UP.



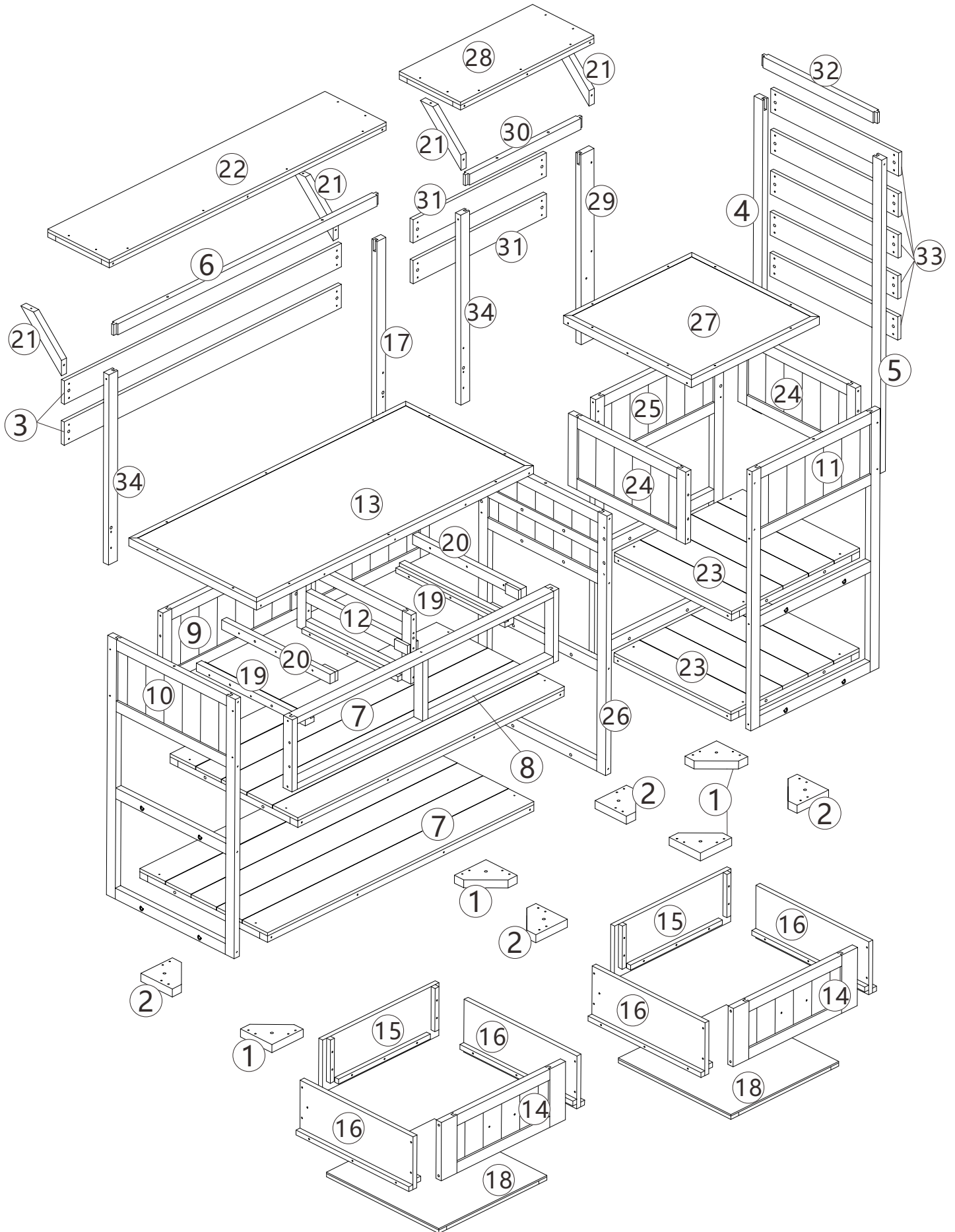

NOTE IMPORTANTE:

- ① PLACEZ TOUTES LES PIÈCES SUR UNE SURFACE PROPRE ET LISSE TELLE QU'UN TAPIS OU UN TAPIS POUR ÉVITER LES PIÈCES D'ÊTRE RAYÉES.
- ② AVANT DE COMMENCER, VEUILLEZ SUIVRE LES INSTRUCTIONS D'ASSEMBLAGE ÉTAPE PAR ÉTAPE.
- ③ NE SERREZ PAS TOUTES LES VIS ET LES BOULONS TANT QUE CET ARTICLE N'EST PAS ENTIÈREMENT INSTALLÉ.

Detail View Vue détaillée

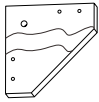
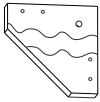
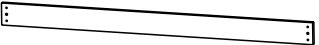

Part List(N717P417963)
Liste des pièces(N717P417963)

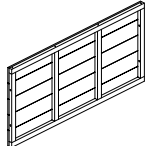
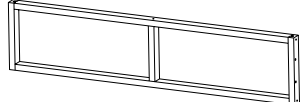
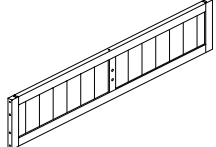
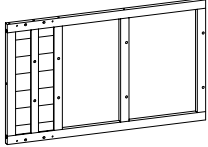
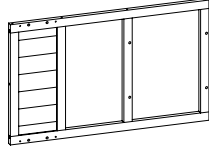
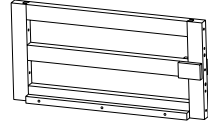
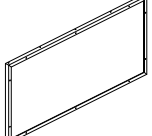
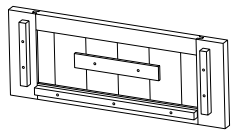
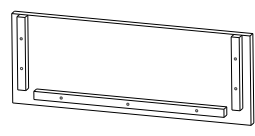
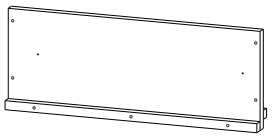
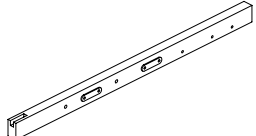
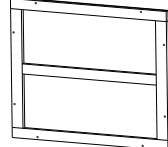
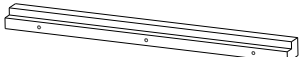
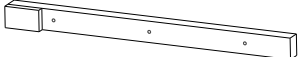
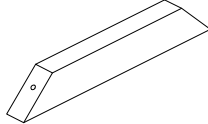
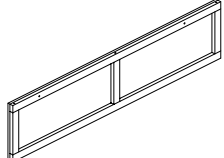
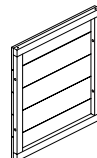
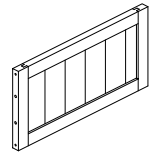
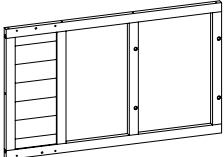
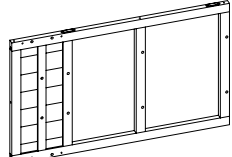
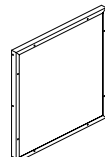
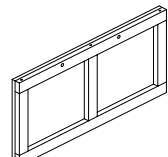
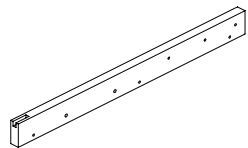
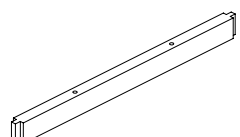
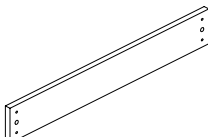
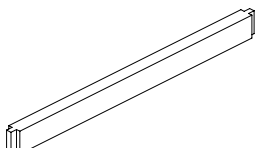
1		2		3		4	
Base 1 4PCS		Base 2 4PCS		Shelf panel Panneau d'étagère 2PCS		Left vertical partition of the storage rack Cloison verticale gauche du rayonnage de stockage 1PC	
5		6		7		8	
Right vertical partition of the storage rack Cloison verticale droite du rayonnage de stockage 1PC		The slat of storage rack La latte du rayonnage de stockage 1PC		Bottom panel Panneau inférieur 2PCS		Front panel Panneau avant 1PC	
9		10		11		12	
Back panel Panneau arrière 1PC		Left side panel Panneau latéral gauche 1PC		Front panel 2 Panneau avant 2 1PC		Middle panel Panneau central 1PC	
13		14		15		16	
Table top Dessus de table 1PC		Front panel of drawer Panneau avant du tiroir 2PCS		Back panel of drawer Panneau arrière du tiroir 2PCS		Side panel of drawer Panneau latéral du tiroir 4PCS	
17		18		19		20	
Right vertical partition of the storage rack Cloison verticale droite du rayonnage de stockage 1PC		Bottom panel of drawer Panneau inférieur du tiroir 2PCS		Support strip of the drawer Bande de support du tiroir 2PCS		Drawer positioning block Bloc de positionnement de tiroir 2PCS	
21		22		23		24	
Support block of shelf Bloc de support d'étagère 4PCS		Shelf of storage rack Étagère de rack de stockage 1PC		Bottom panel 2 Panneau inférieur 2 2PCS		Right side panel Panneau latéral 2PCS	
25		26		27		28	
Back panel 2 Panneau arrière 2 1PC		Middle side panel Panneau latéral central 1PC		Table top 2 Dessus de table 2 1PC		Shelf of storage rack 2 Étagère de rack de stockage 2 1PC	
29		30		31		32	
Right vertical partition of the storage rack 2 Cloison verticale droite du rayonnage de stockage 2 1PC		The slat of storage rack 2 La latte du rayonnage de stockage 2 1PC		Storage rack panel 2 Panneau pour rayonnage de stockage 2 2PCS		The slat of storage rack 3 La latte du rayonnage de stockage 3 1PC	

Part List(N717P417963)
Liste des pièces(N717P417963)

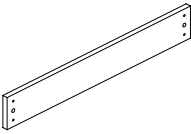
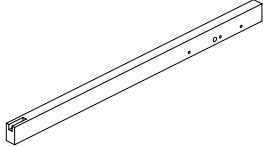
<p>33</p> 	<p>34</p> 		
<p>Storage rack panel 3 Panneau pour rayonnage de stockage 3 5PCS</p>	<p>Left vertical partition of the storage rack Cloison verticale gauche du rayonnage de stockage 2PCS</p>		

Hardware List
Liste du matériel

<p>A</p>  <p>3.5*60</p>	<p>B</p>  <p>3.5*40</p>	<p>C</p>  <p>3.5*25</p>	<p>D</p>  <p>3.0*16</p>
<p>Ph zinc screws Vis de zinc ph 6+1 pcs</p>	<p>Ph zinc screws Vis de zinc ph 83+1pcs</p>	<p>Ph zinc screws Vis de zinc ph 68+1pcs</p>	<p>Ph zinc screws Vis de zinc ph 83+1pcs</p>
<p>E</p>  <p>Wood dowel Cheville à bois 60+2 pcs</p>	<p>F</p>  <p>Ground nail Clou de sol 2pcs</p>	<p>G</p>  <p>L shape metal Métal en forme de L 2pcs</p>	<p>H</p>  <p>Right-angle iron Cornière en fer 2pcs</p>
<p>I</p>  <p>Fixed wheel Roue fixe 4pcs</p>	<p>J</p>  <p>Brake wheel Roue de frein 4pcs</p>	<p>K</p>  <p>Corner brace Équerre d'angle 16pcs</p>	<p>L</p>  <p>3.5*50 Ph zinc screws Vis de zinc ph 10+1pcs</p>
<p>M</p>  <p>3.0*38</p>	<p>N</p>  <p>M4*18</p>	<p>O</p>  <p>M6*55</p>	<p>P</p>  <p>3.5*35</p>
<p>Ph zinc screws Vis de zinc ph 7+1pcs</p>	<p>Ph zinc bolt Boulon de zinc ph 4+1pcs</p>	<p>Ph zinc bolt Boulon de zinc ph 16+1pcs</p>	<p>Ph zinc screws Vis de zinc ph 12+1pcs</p>
<p>Q</p>  <p>3.0*14</p>	<p>R</p>  <p>Open-end Wrench Clé à fourche 1pc</p>	<p>S</p>  <p>Drawer stopper Butée de tiroir 4pcs</p>	<p>T</p>  <p>Connecting iron piece Pièce de fer de raccordement 1pc</p>
<p>Ph zinc screws Vis de zinc ph 4+1pcs</p>	<p>Open-end Wrench Clé à fourche 1pc</p>	<p>Drawer stopper Butée de tiroir 4pcs</p>	<p>Connecting iron piece Pièce de fer de raccordement 1pc</p>
<p>U</p>  <p>3.0*30</p>	<p>V</p>  <p>Door handle Poignée de porte 2pcs</p>	<p>L shape wrench Clé en L 1pc</p>	
<p>Ph zinc screws Vis de zinc ph 6+1pcs</p>	<p>Door handle Poignée de porte 2pcs</p>	<p>L shape wrench Clé en L 1pc</p>	

ASSEMBLY TOOLS REQUIRED(NOTINCLUDED)
OUTILS D'ASSEMBLAGE REQUIS (NON INCLUS)



PLEASE BE CAREFUL DO NOT DAMAGE THE HOLE POSITION WHEN YOU USE POWERTOOLS!

VEUILLEZ FAIRE ATTENTION À NE PAS ENDOMMAGER LA POSITION DU TROU LORS DE L'UTILISATION D'OUTILS ÉLECTRIQUES!

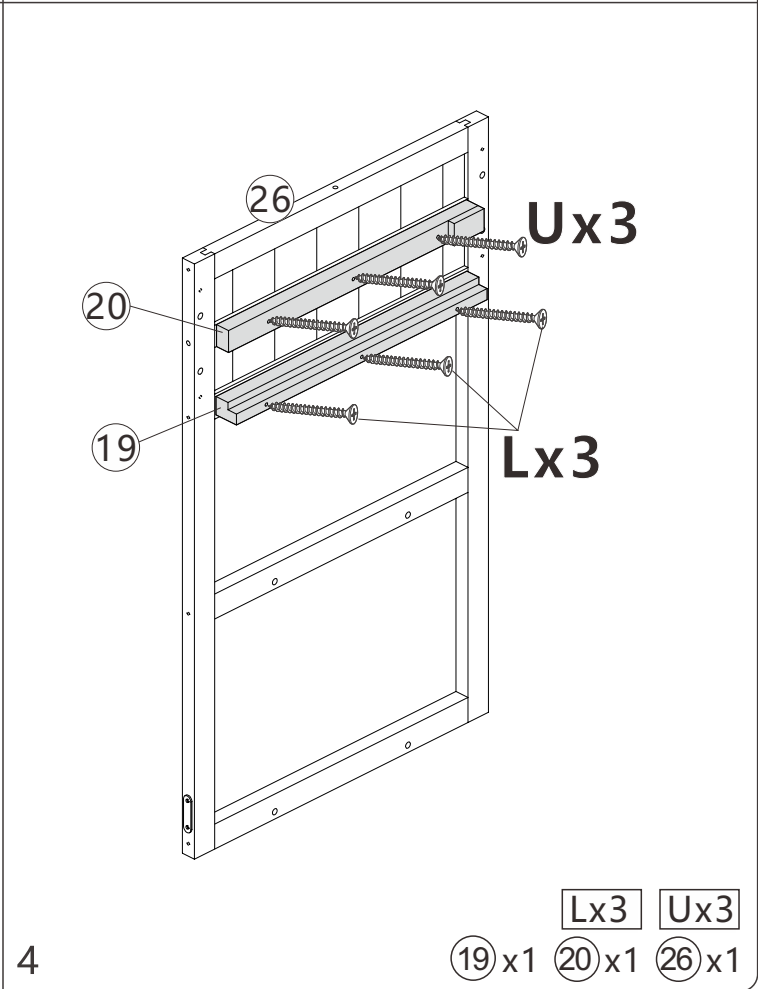
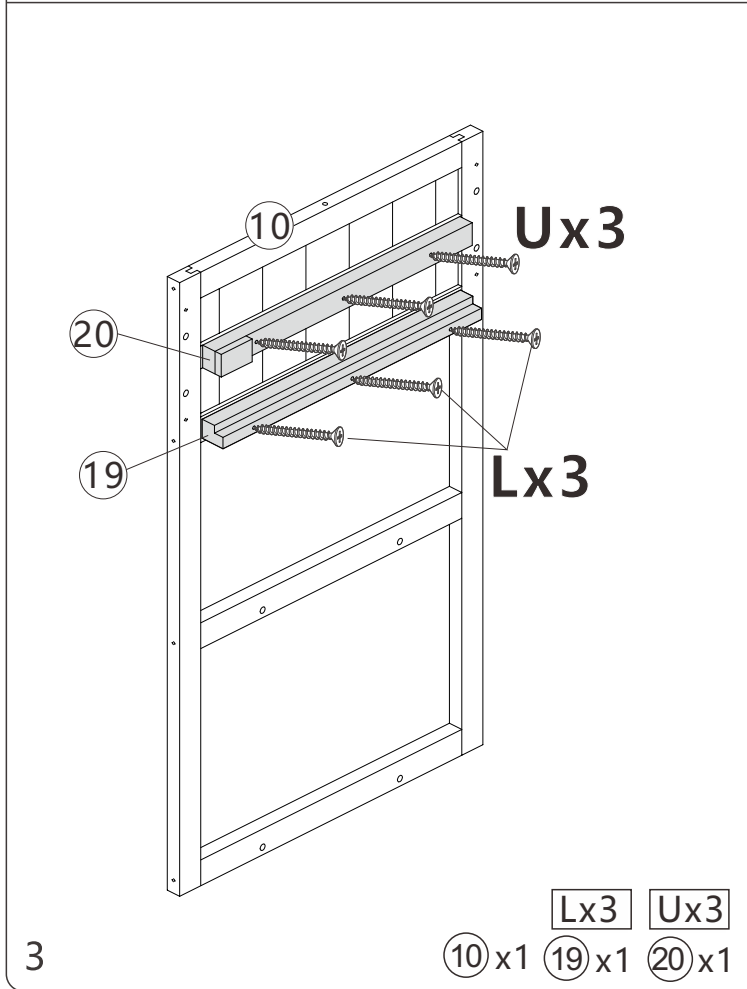
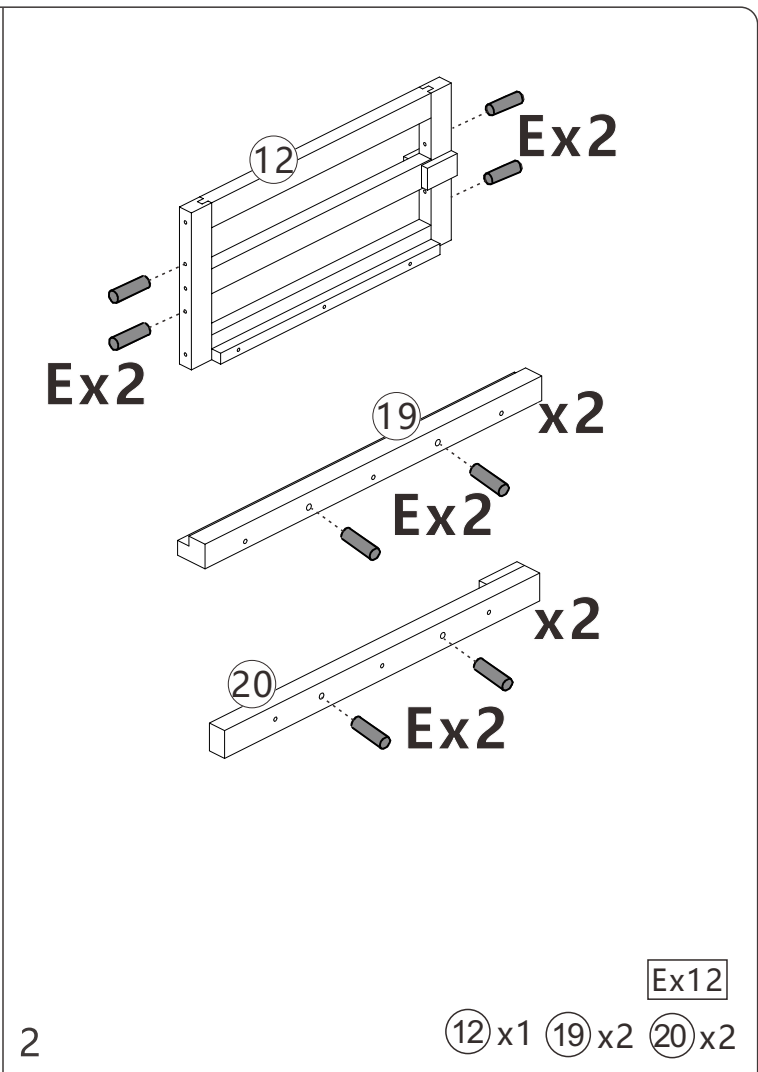
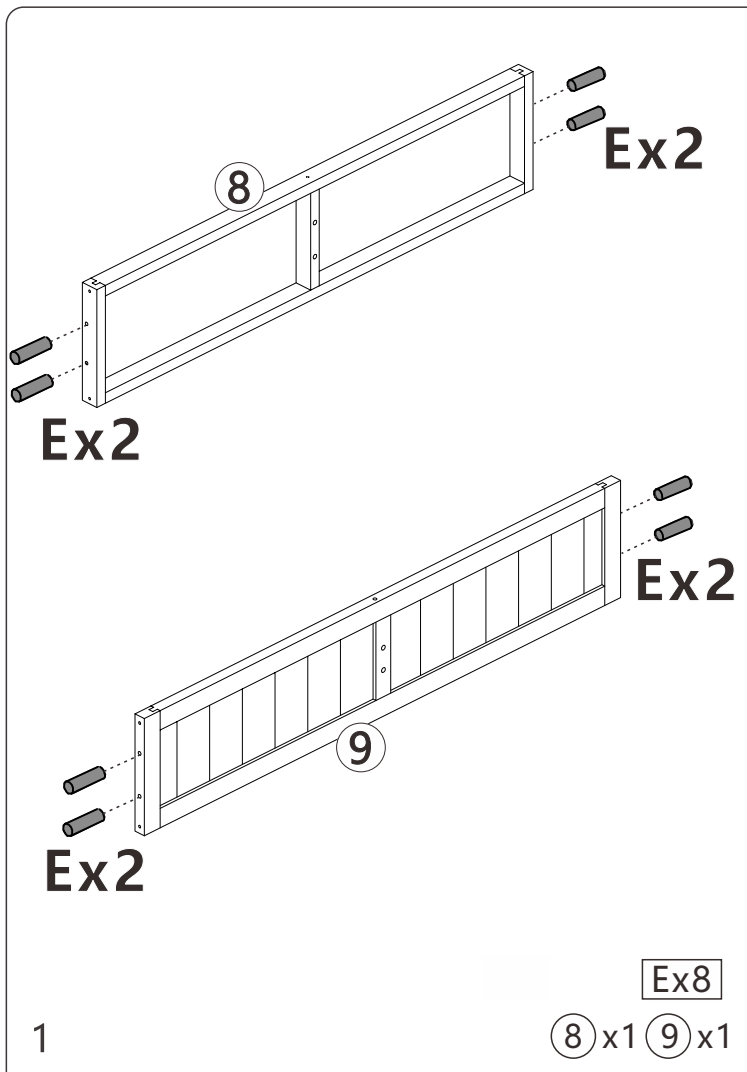

- ⑨ x1 ⑩ x1
- ⑫ x1 ⑫ x1
- Bx4 Lx2

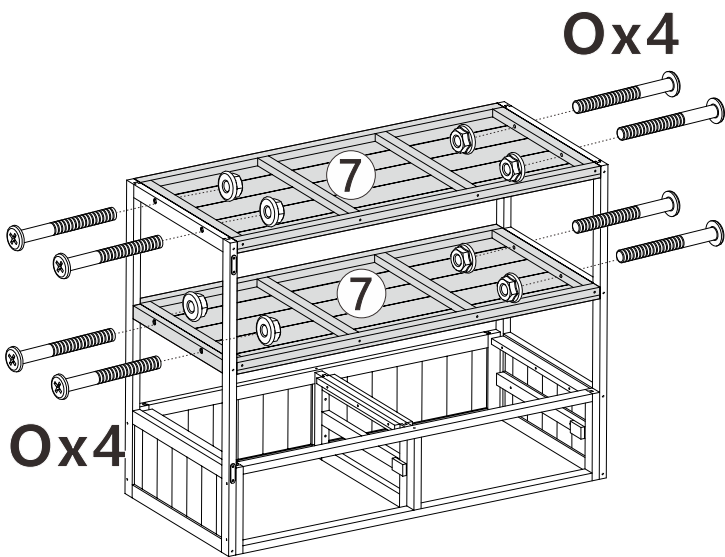
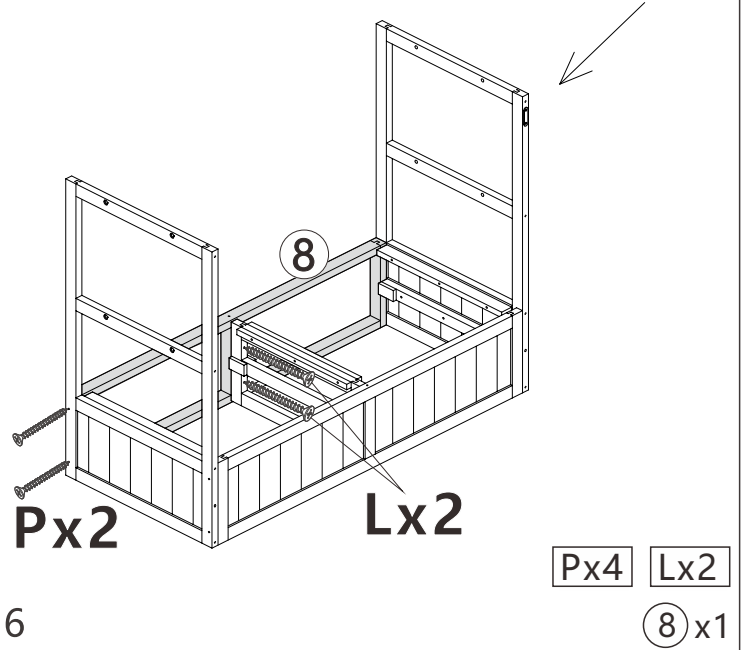
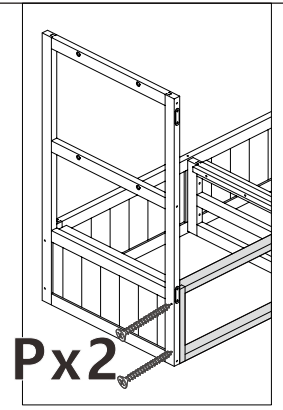
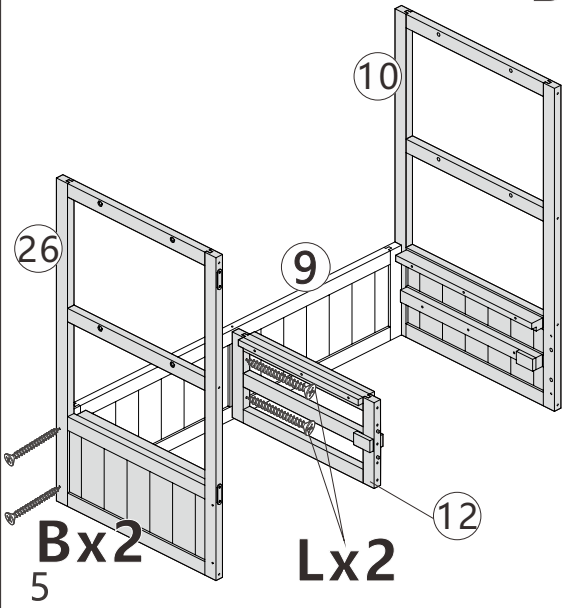
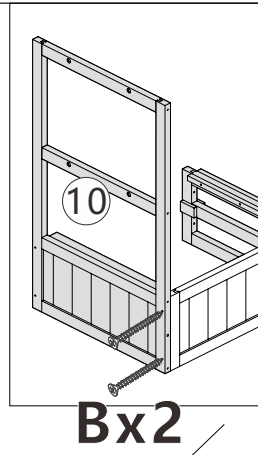

7

Ox8

⑦ x2

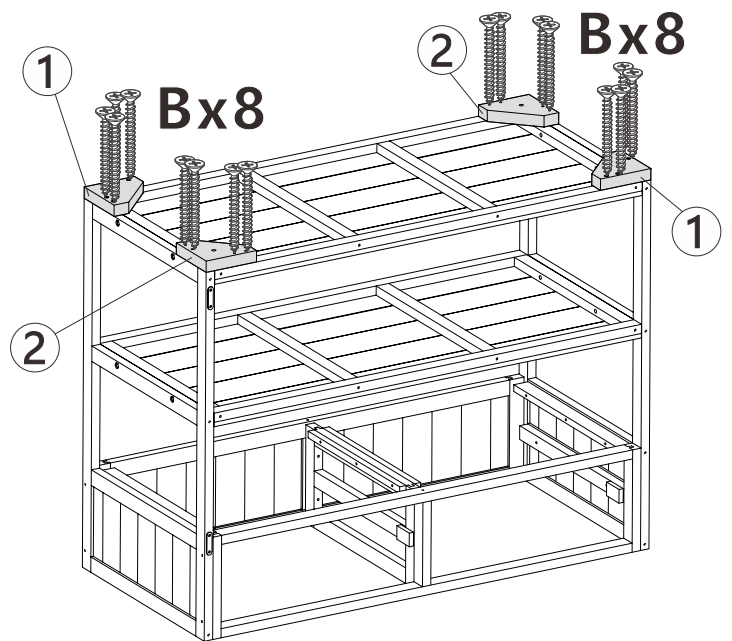

8

Bx16

① x2 ② x2

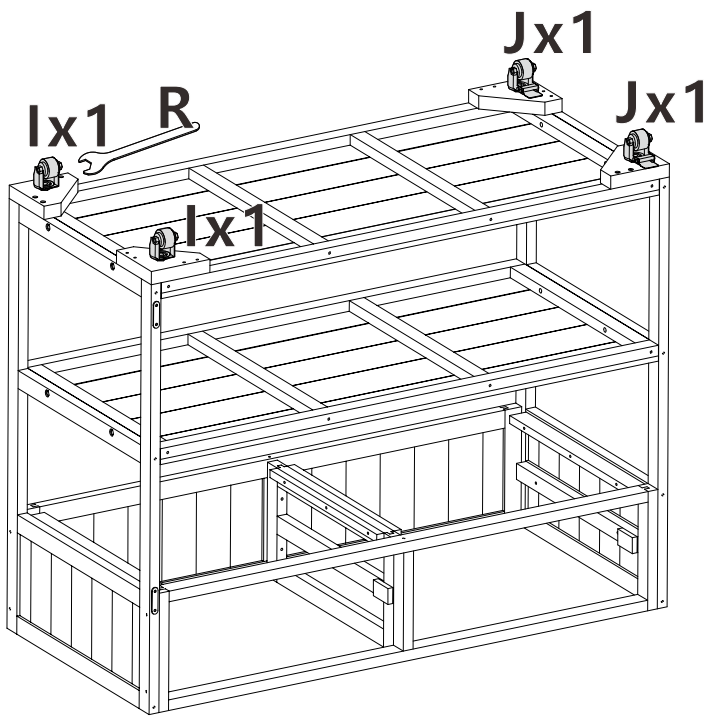

9

Ix2 Jx2 Rx1

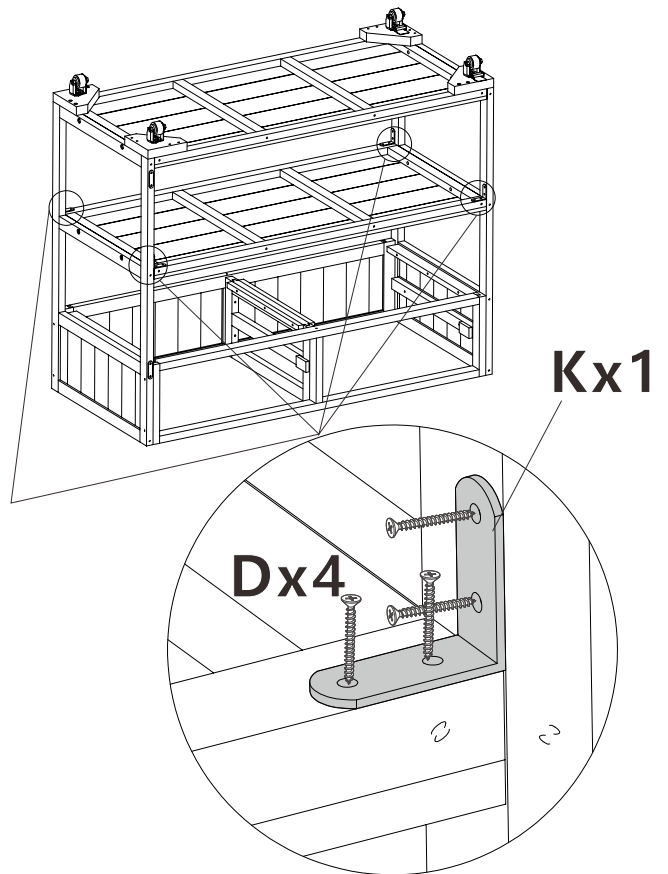

Level with the outside
Au même niveau que l'extérieur

Dx16 Kx4

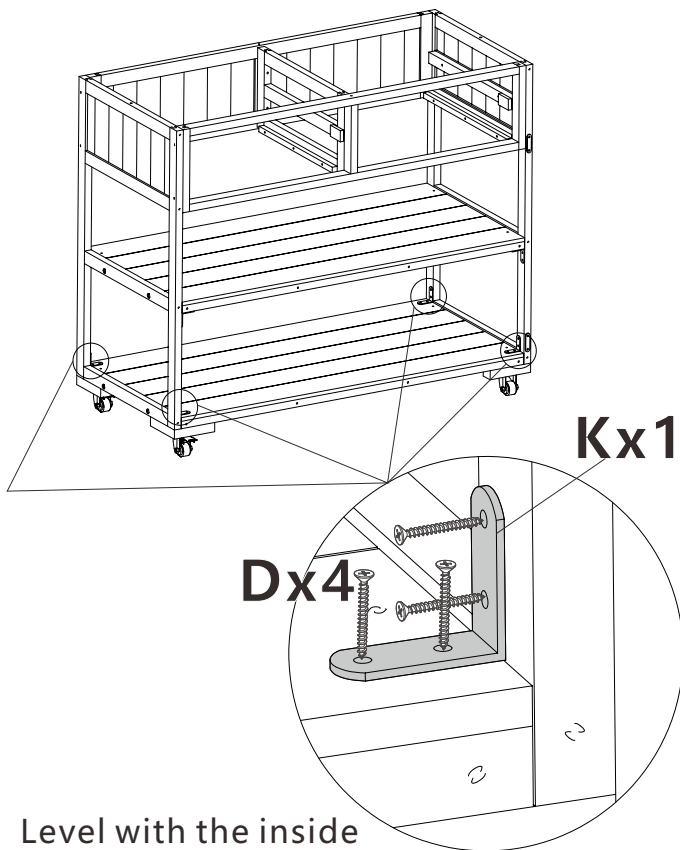

Level with the inside
Au niveau de l'intérieur

11

Dx16 Kx4

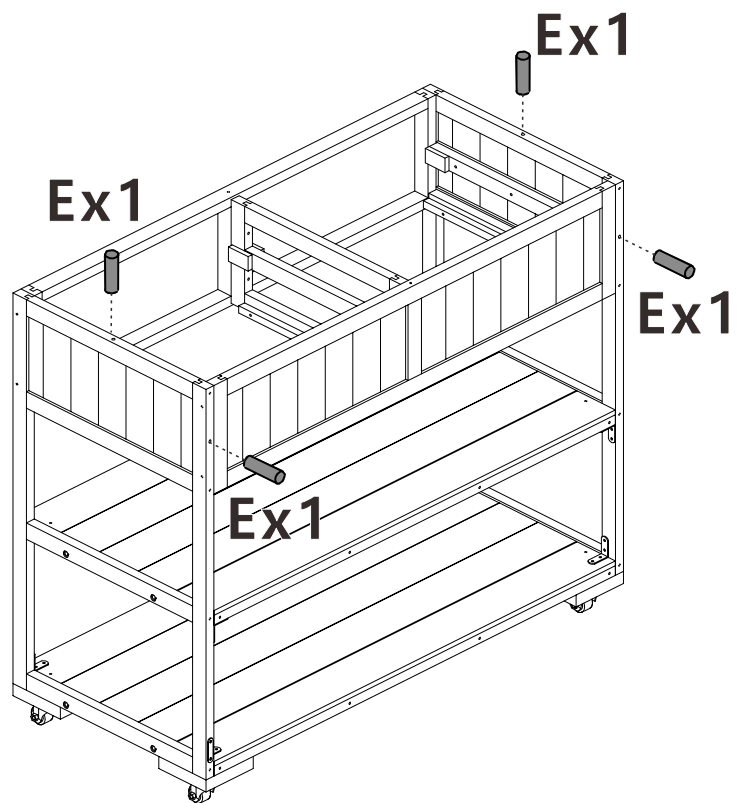

12

Ex4

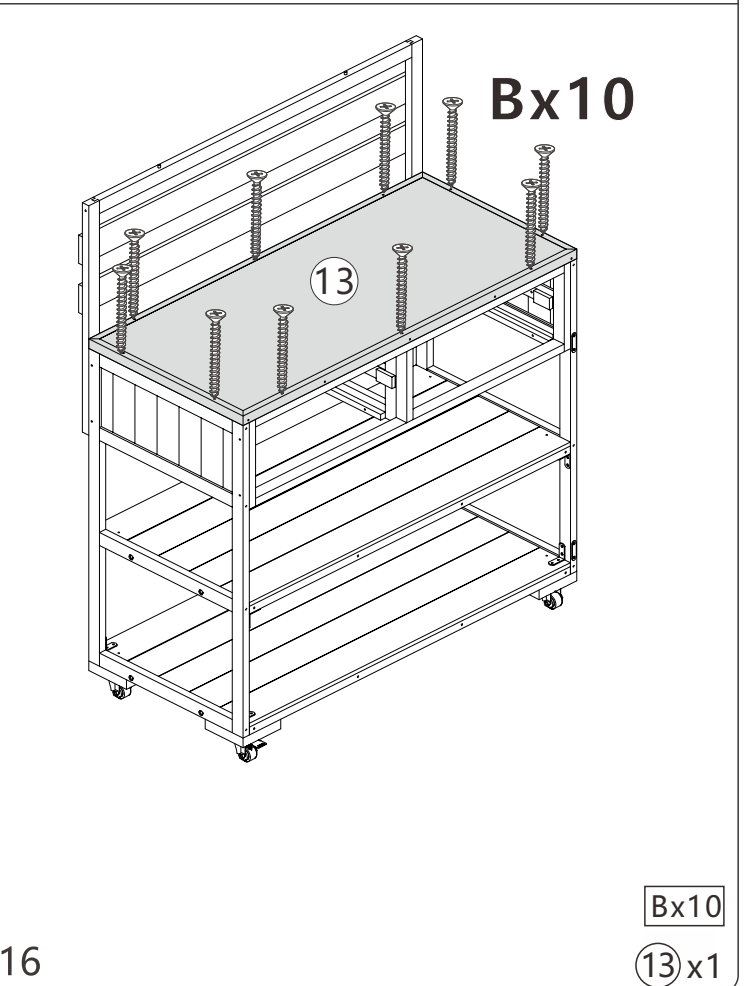
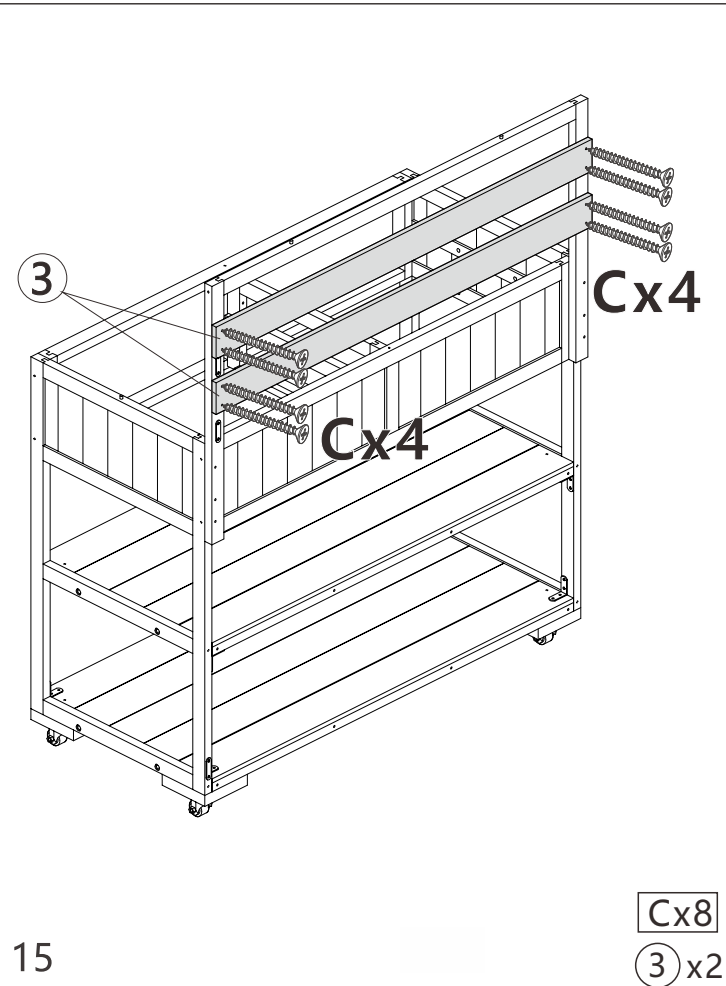
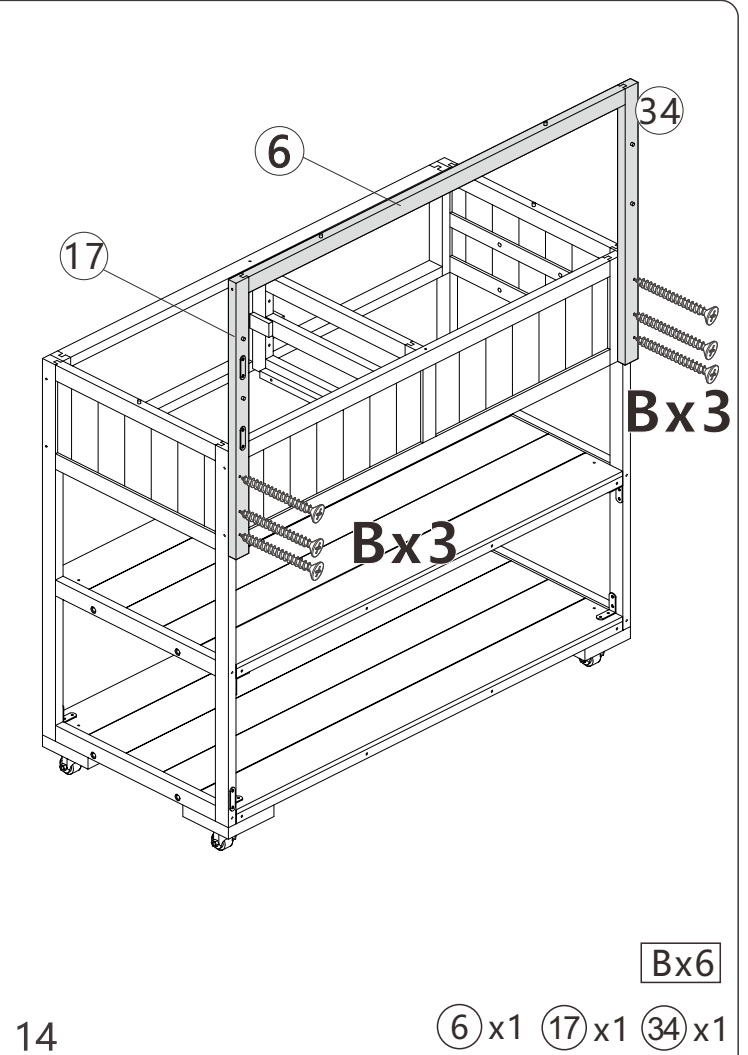
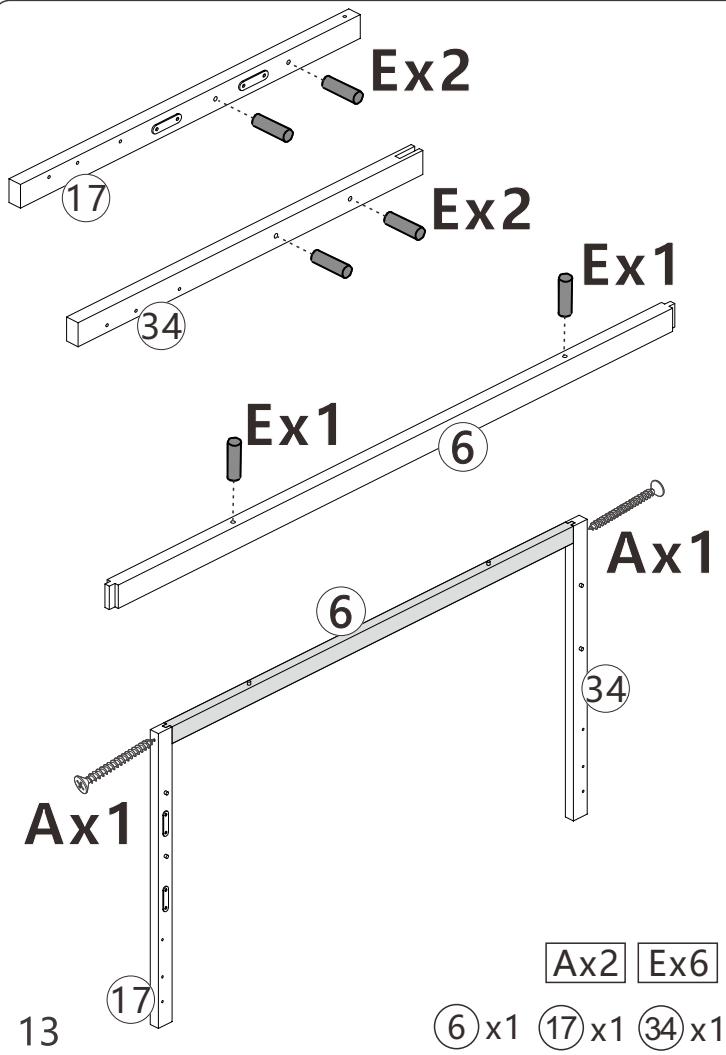

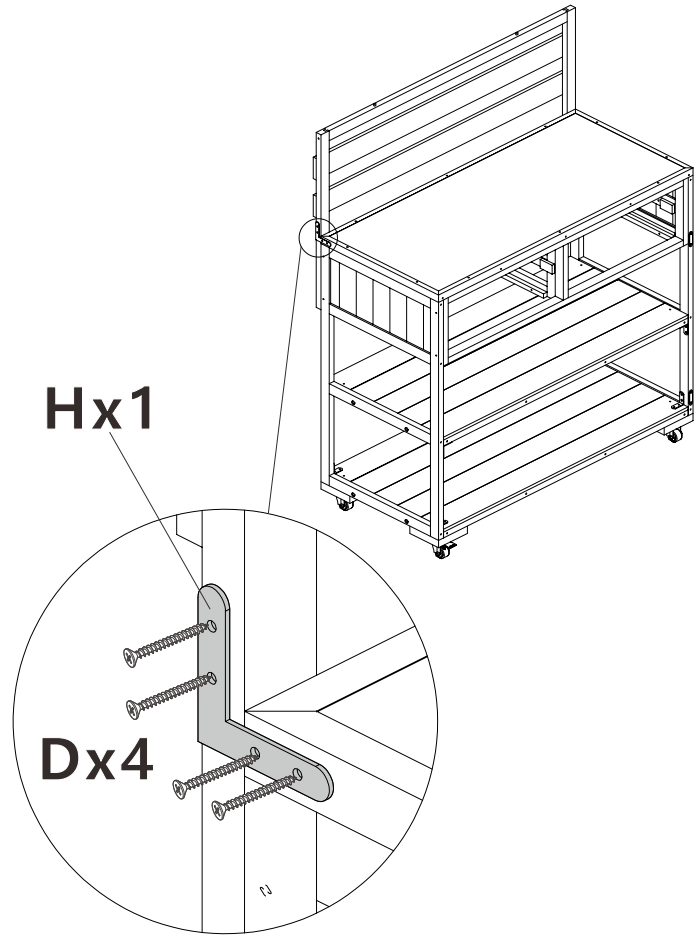

17

Dx4 Hx1

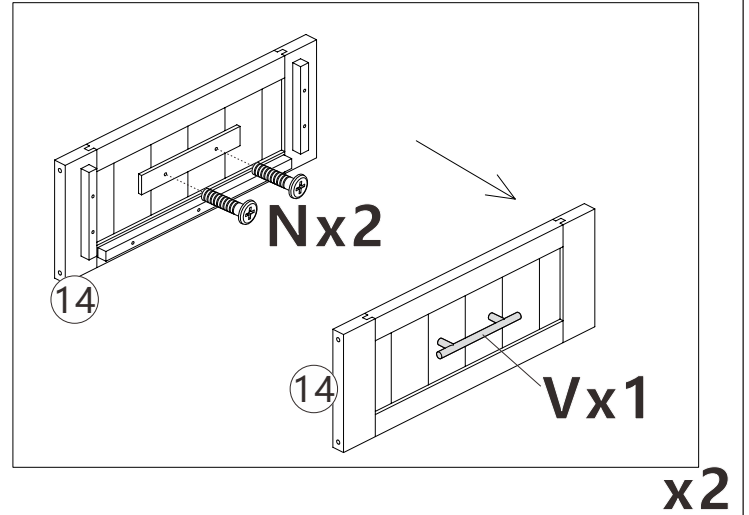

18

Nx4 Vx2
14 x2

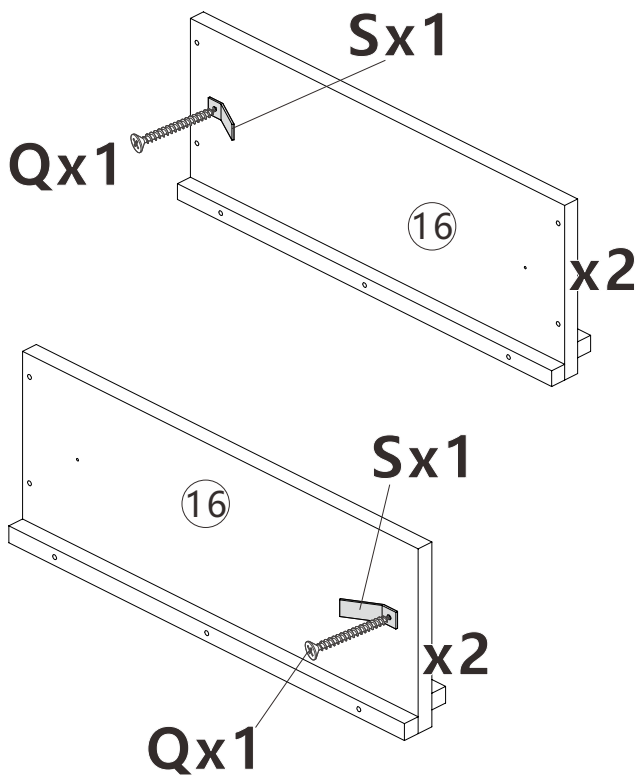

19

Qx4 Sx4
16 x2

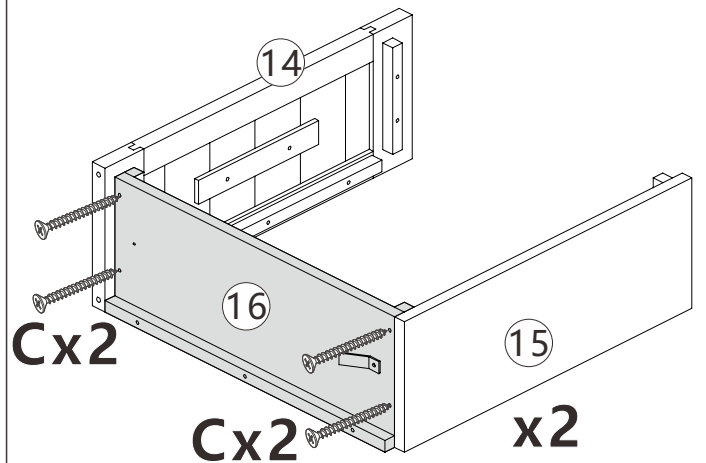

20

Cx8
14 x2 15 x2 16 x2

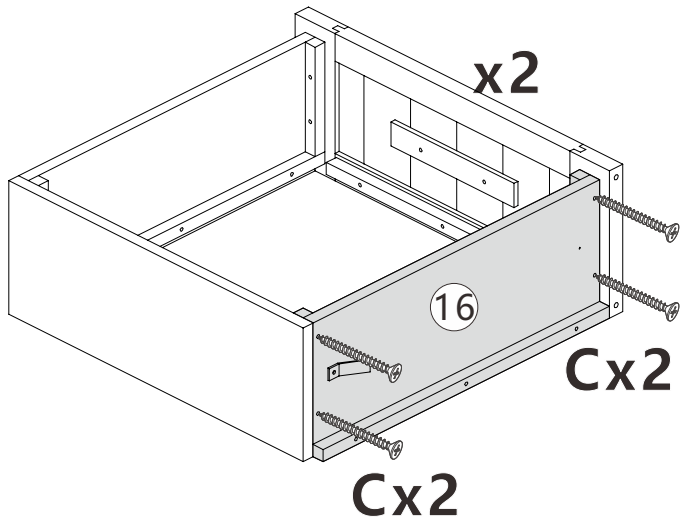

21

Cx8
 16 x2

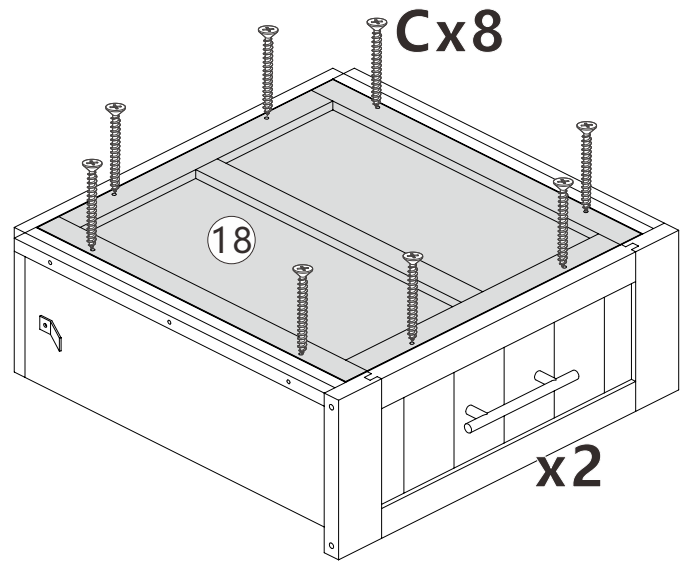

22

Cx16
 18 x2

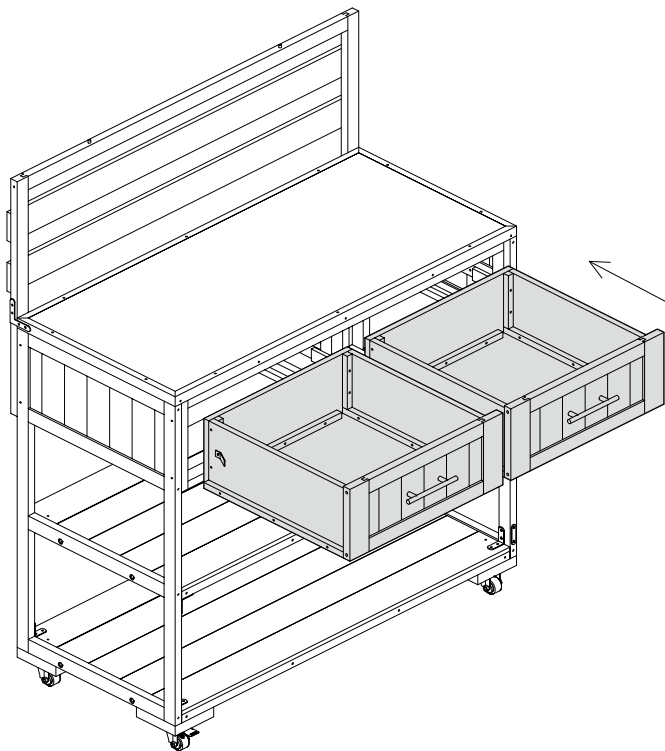

23

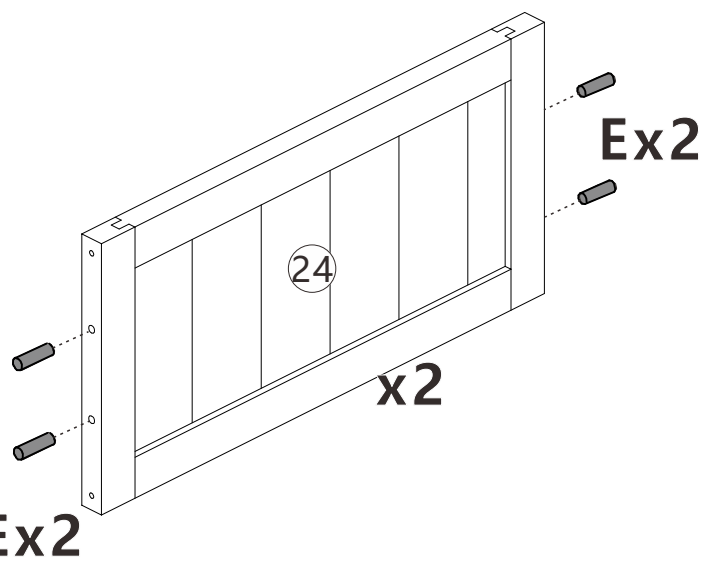

24

Ex8
 24 x2

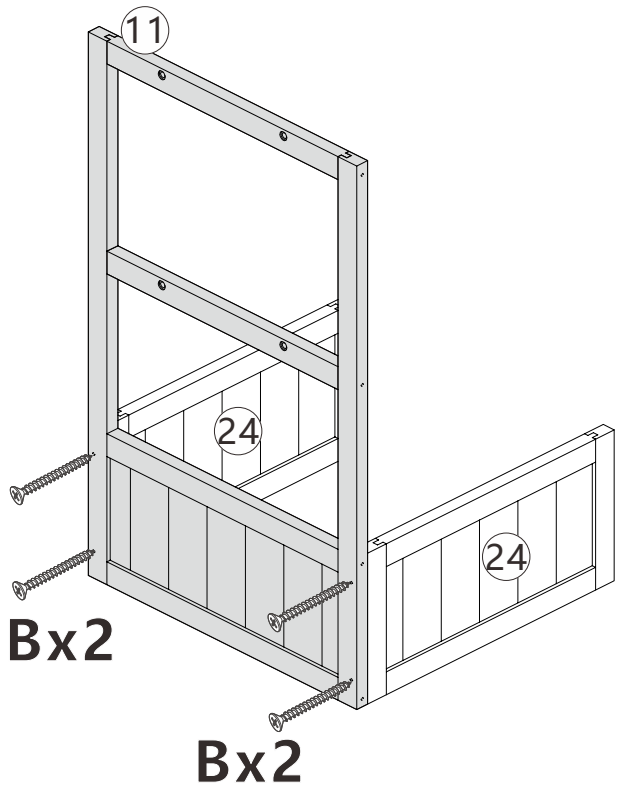

25 Bx4
(11)x1 (24)x2

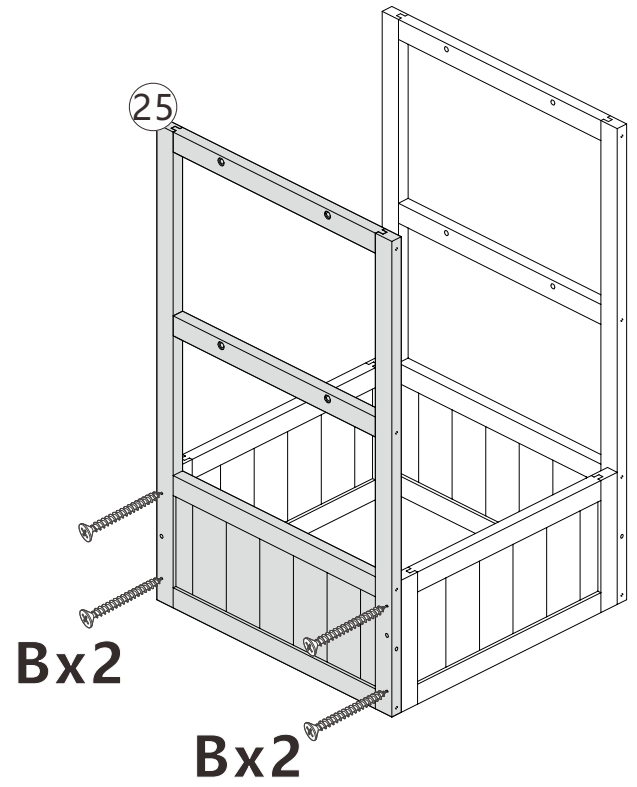

26 Bx4
(25)x1

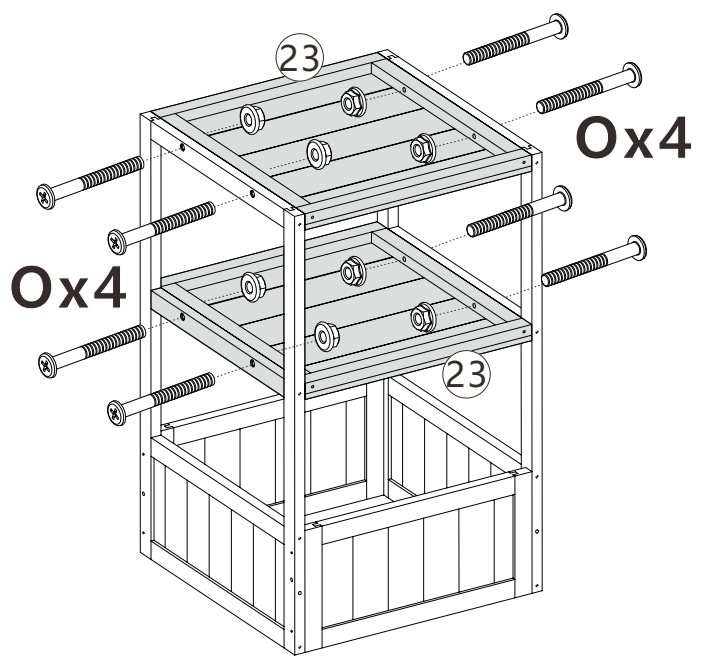

27 Ox8
(23)x2

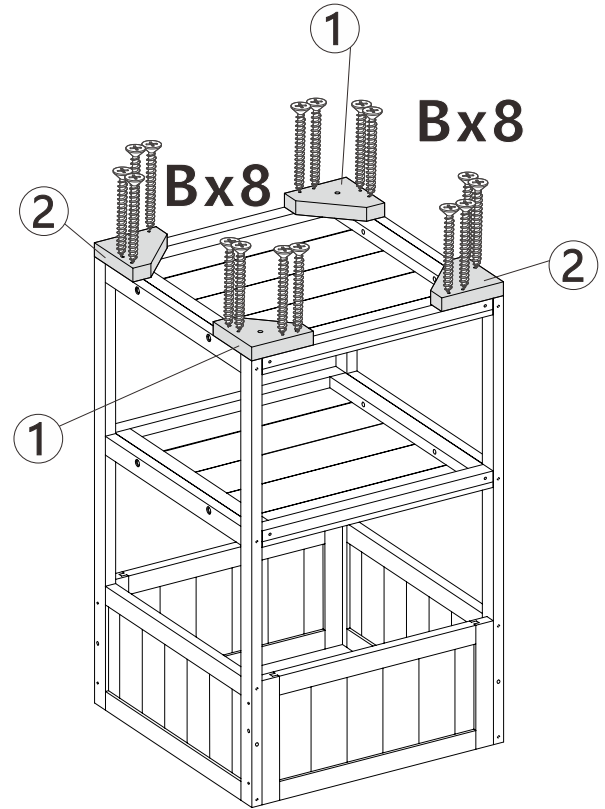

28 Bx16
(1)x2 (2)x2

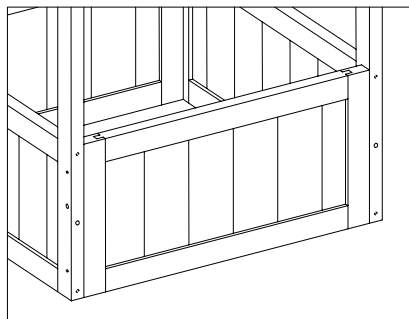
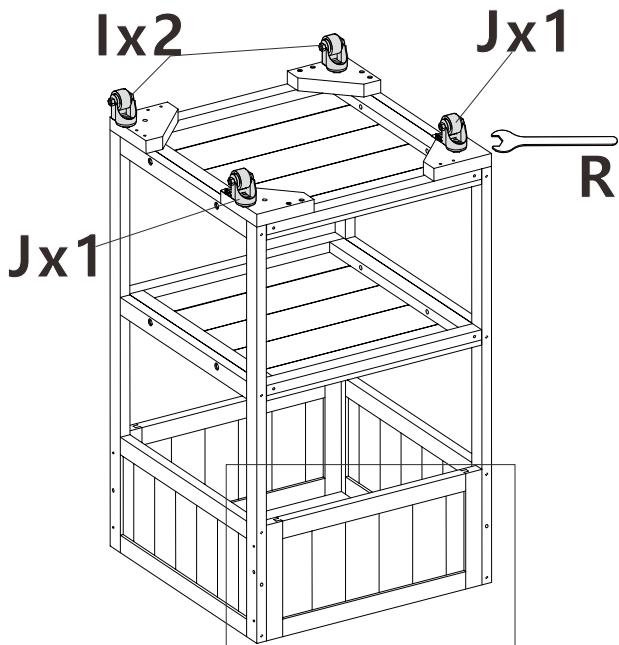

29

Ix2 Jx2 Rx1

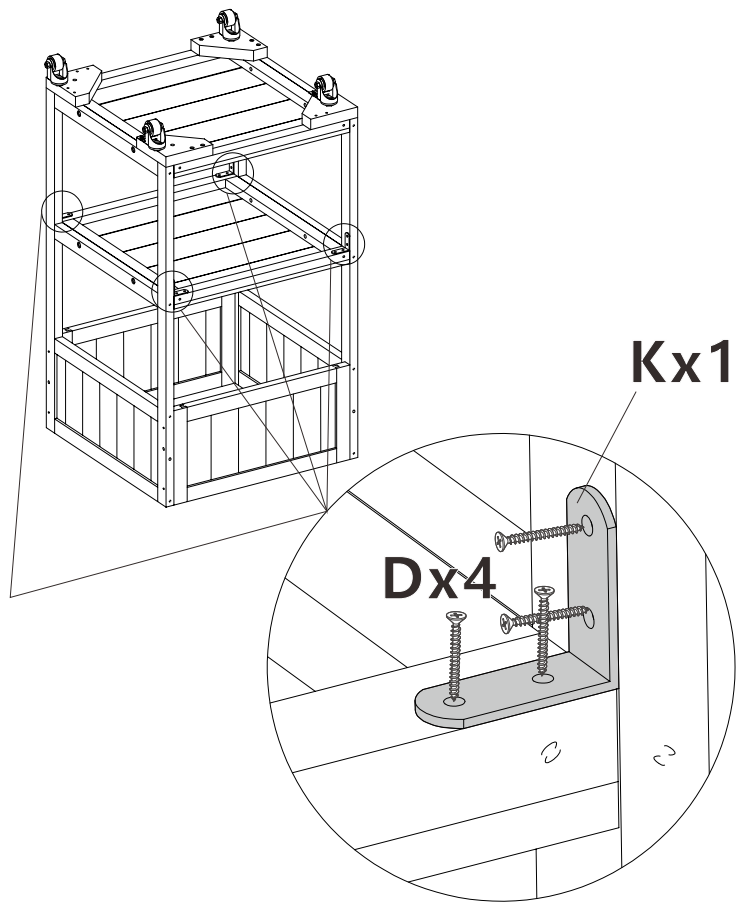

Level with the outside
Au même niveau que l'extérieur

30

Dx16 Kx4

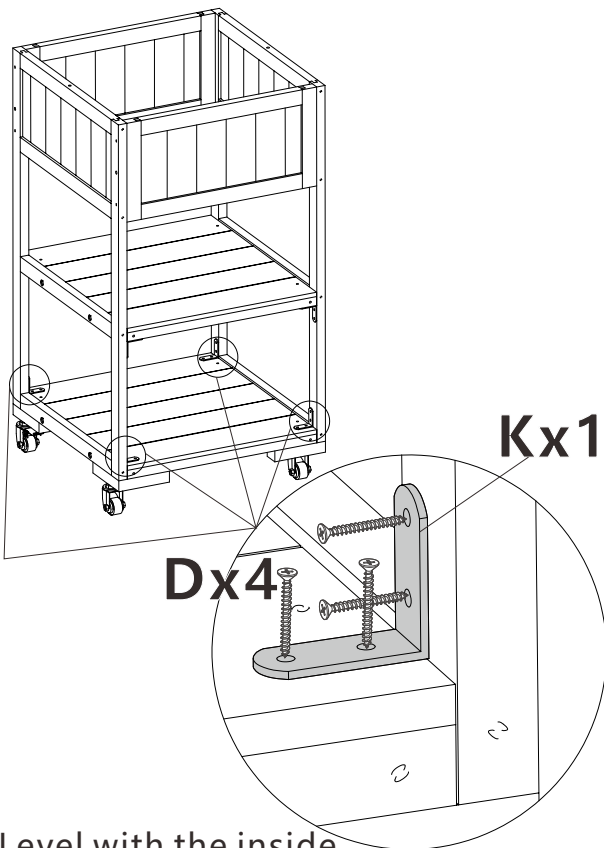

Level with the inside
Au niveau de l'intérieur

31

Dx16 Kx4

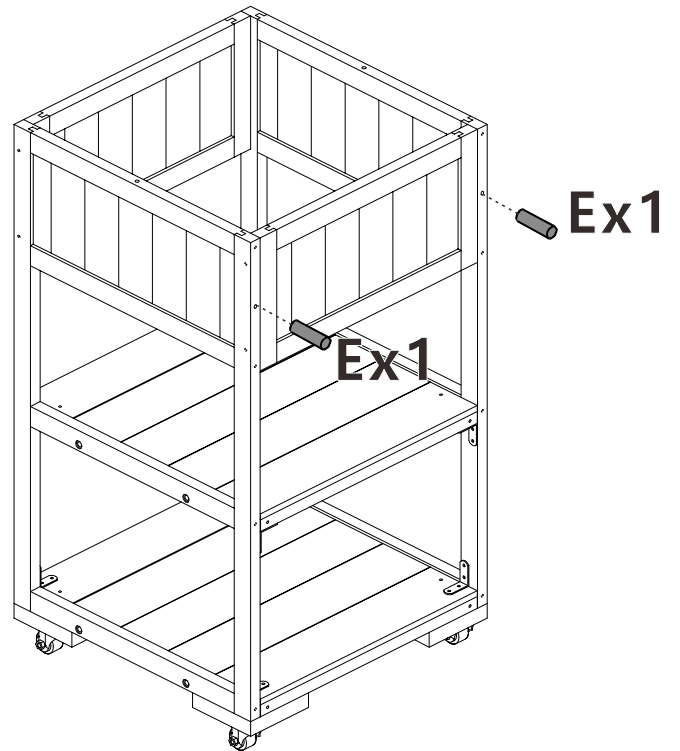

32

Ex2

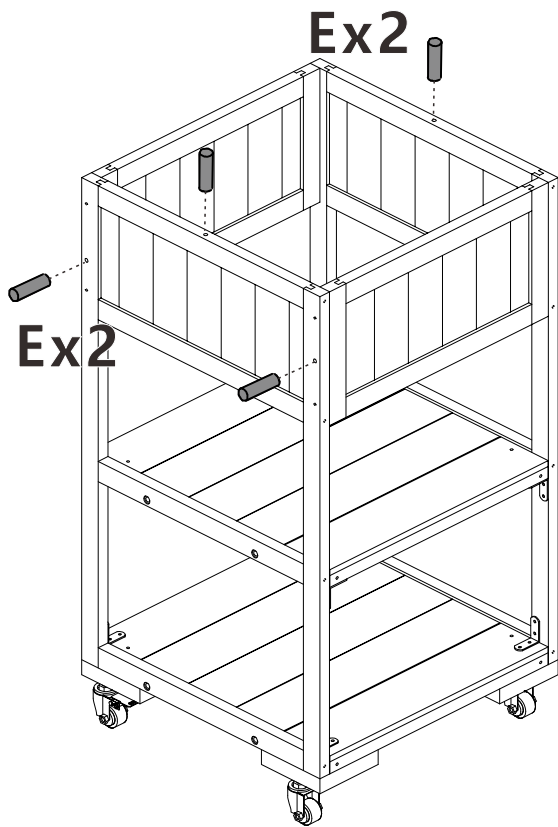

33

Ex4

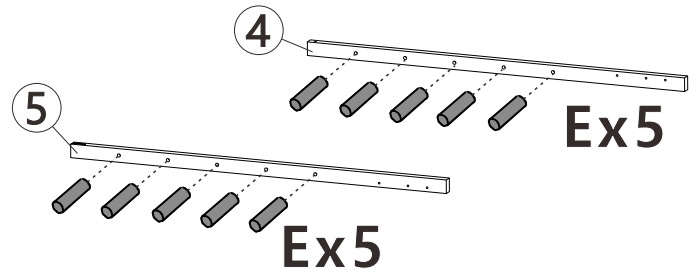

34

Ax2 Ex10

4 x1 5 x1 32 x1

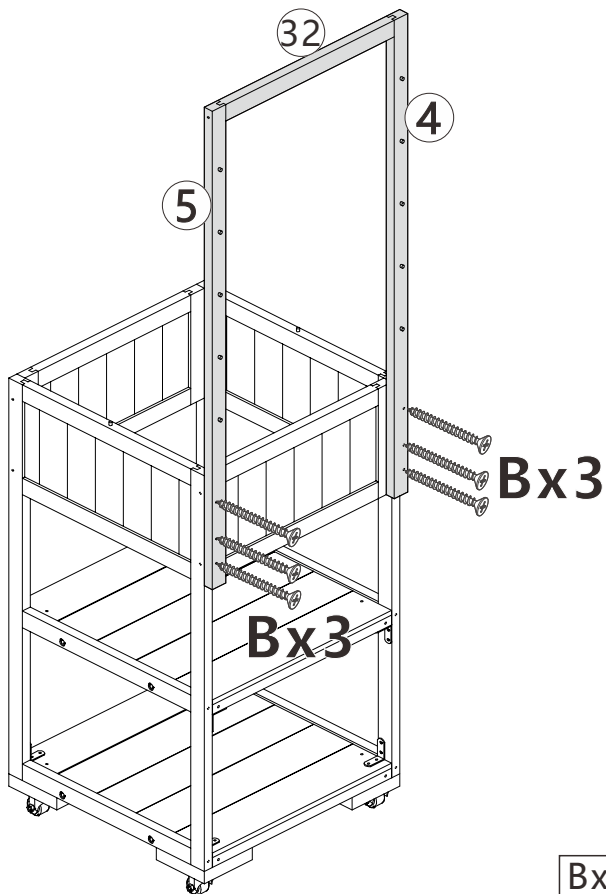
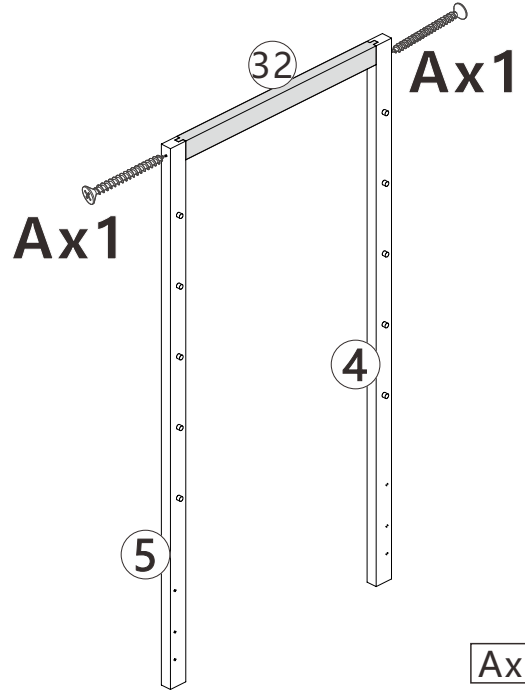

35

Bx6

4 x1 5 x1 32 x1

36

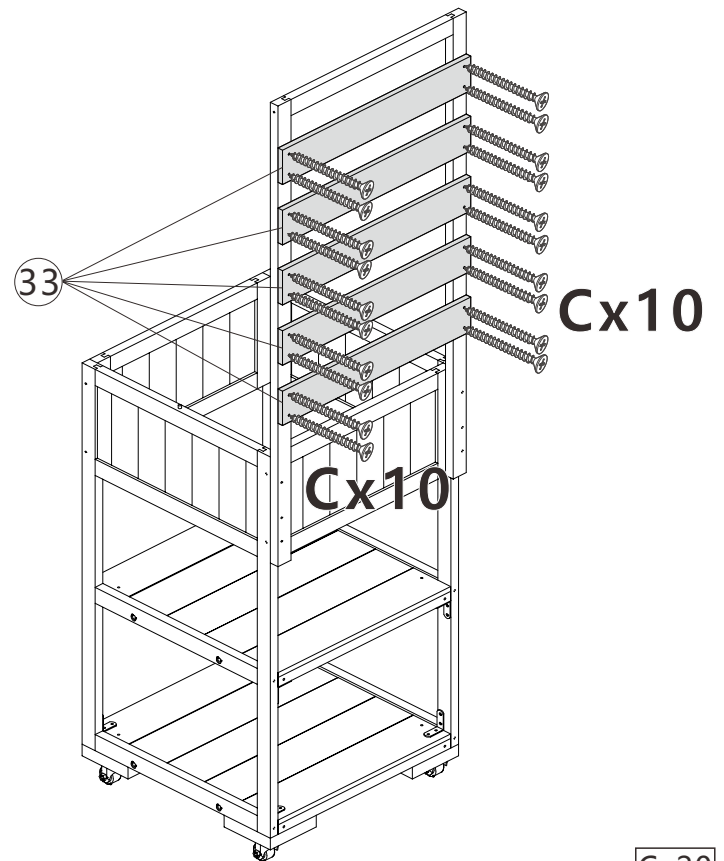

Cx20

33 x5

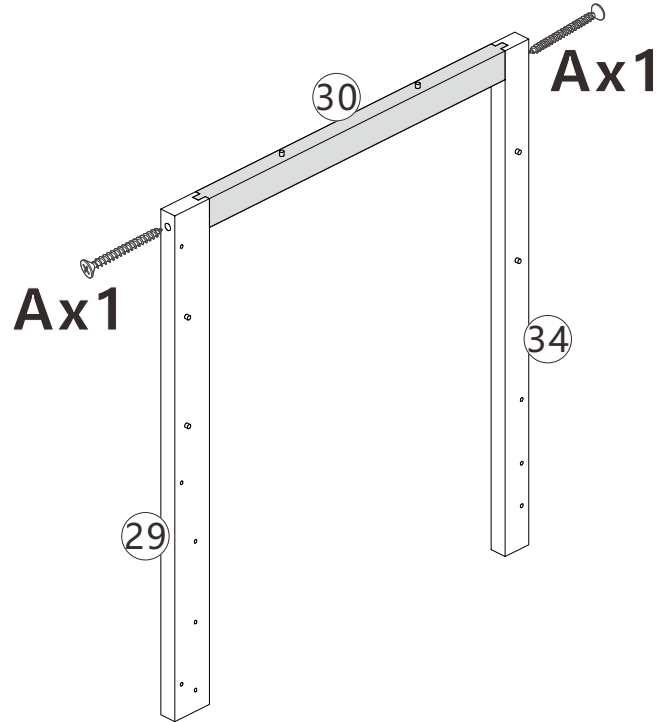
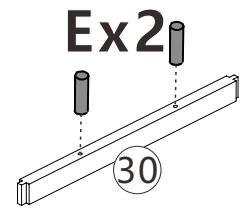
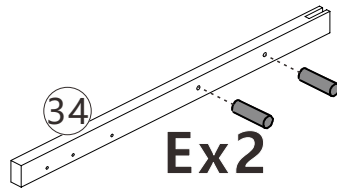
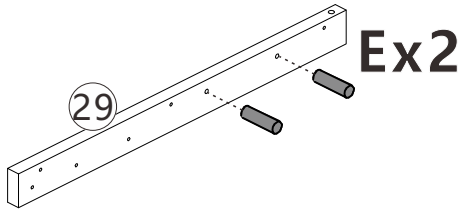

37

Ax2 Ex6
 29 x1 30 x1 34 x1

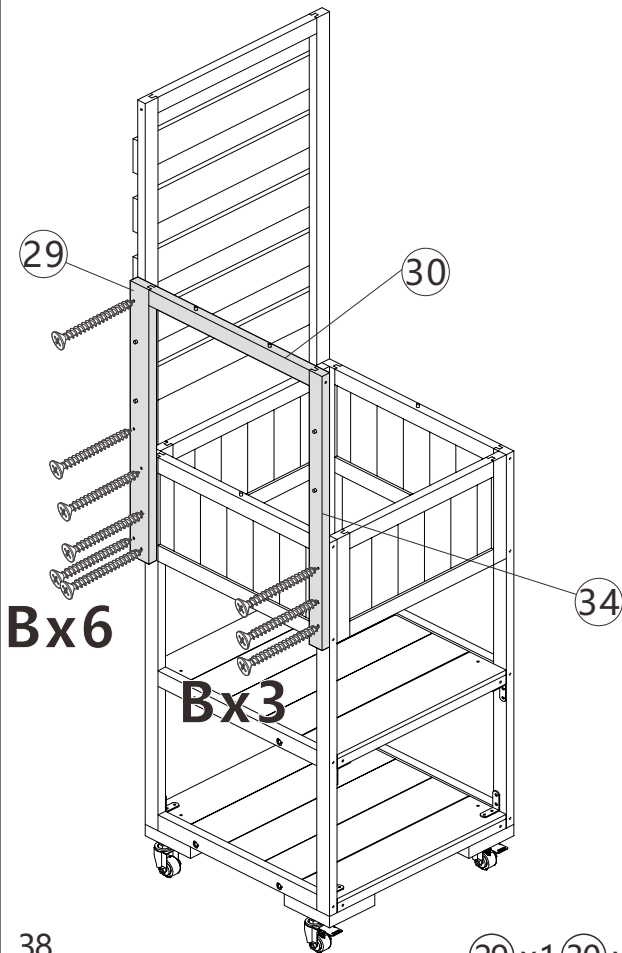

38

Bx9
 29 x1 30 x1 34 x1

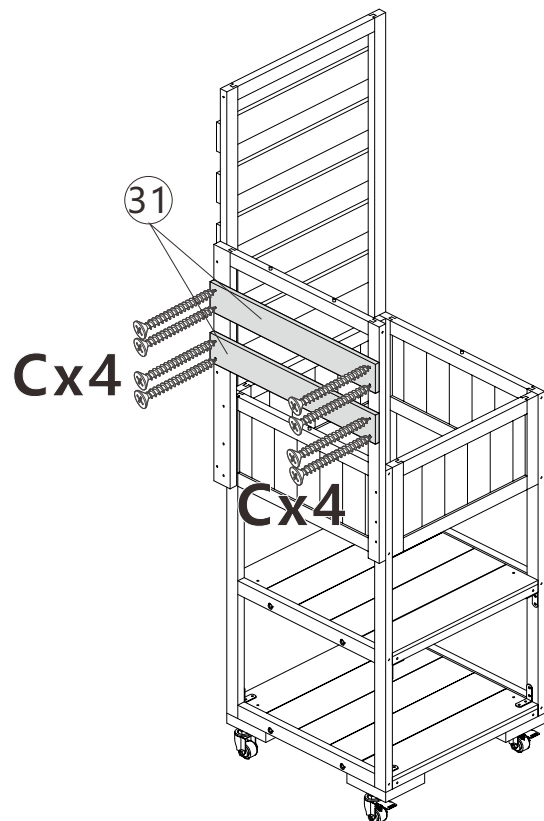

39

Cx8
 31 x2

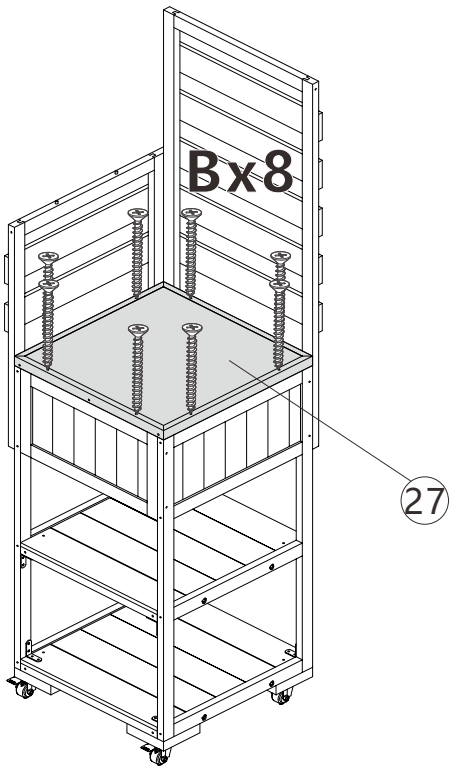

40

Bx8
27 x1

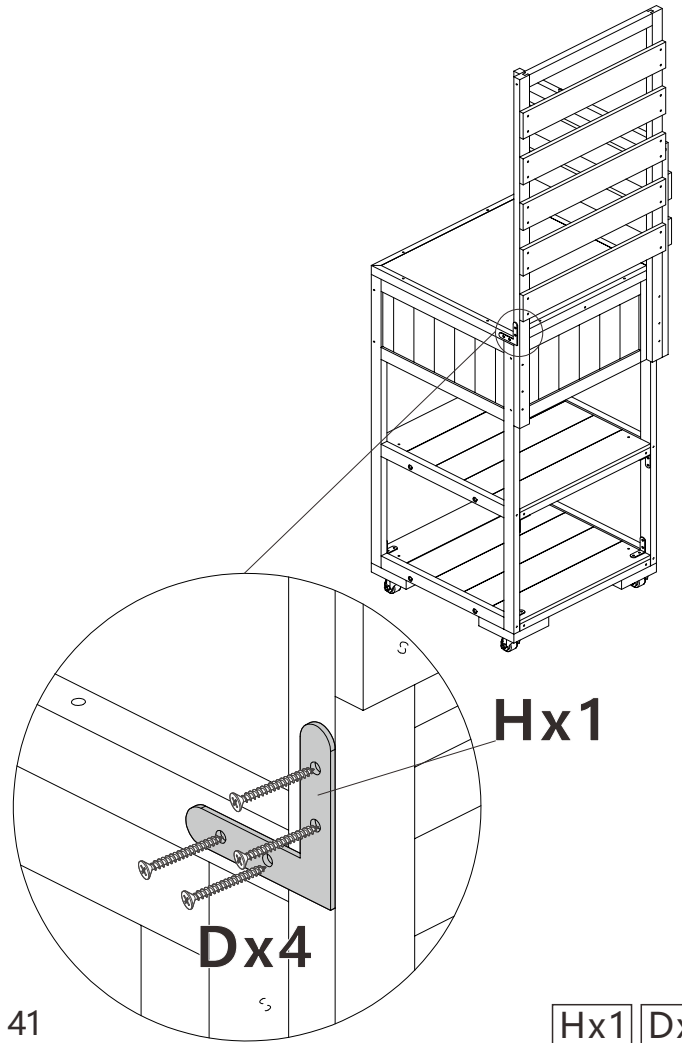

41

Hx1 Dx4

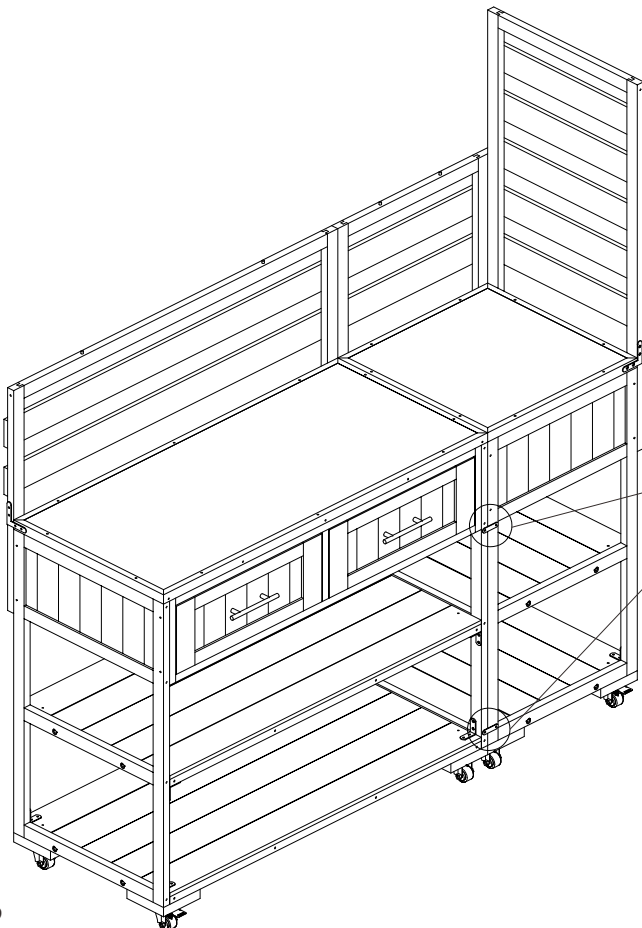

42

Dx2

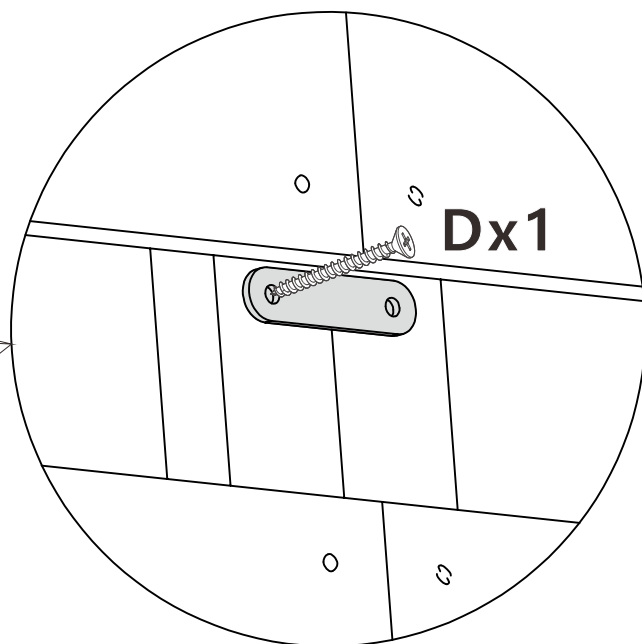
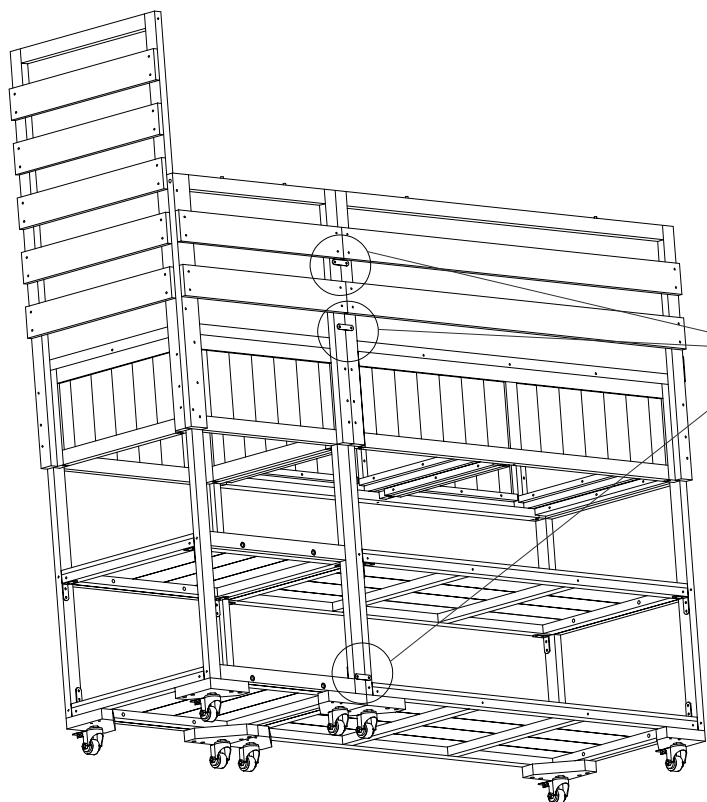

43

Dx3

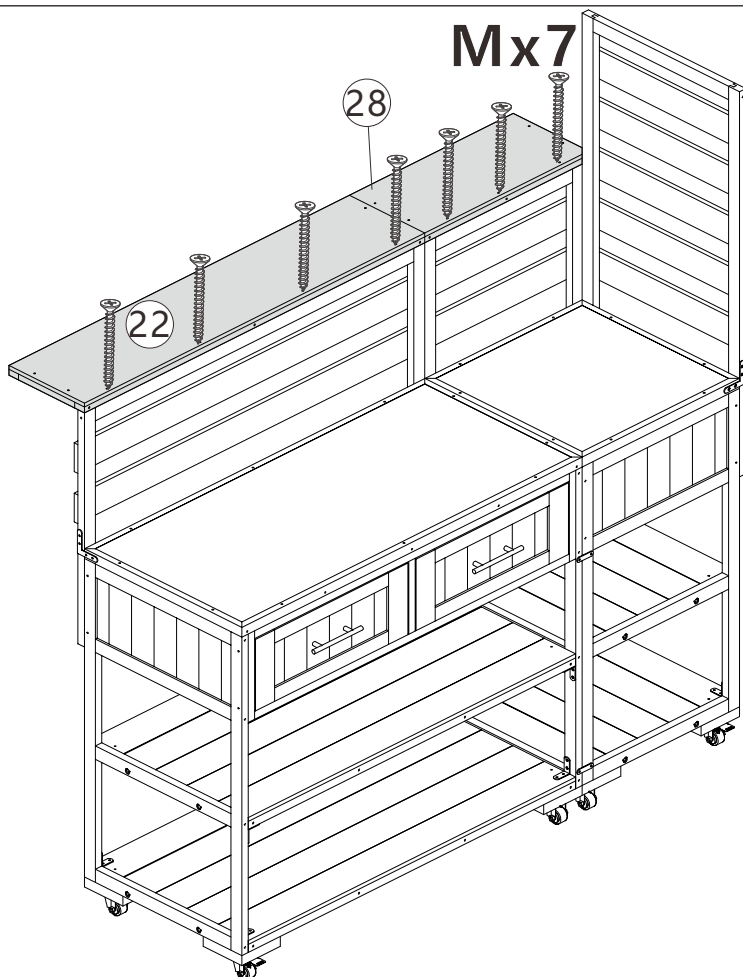

44

Mx7

22x1 28x1

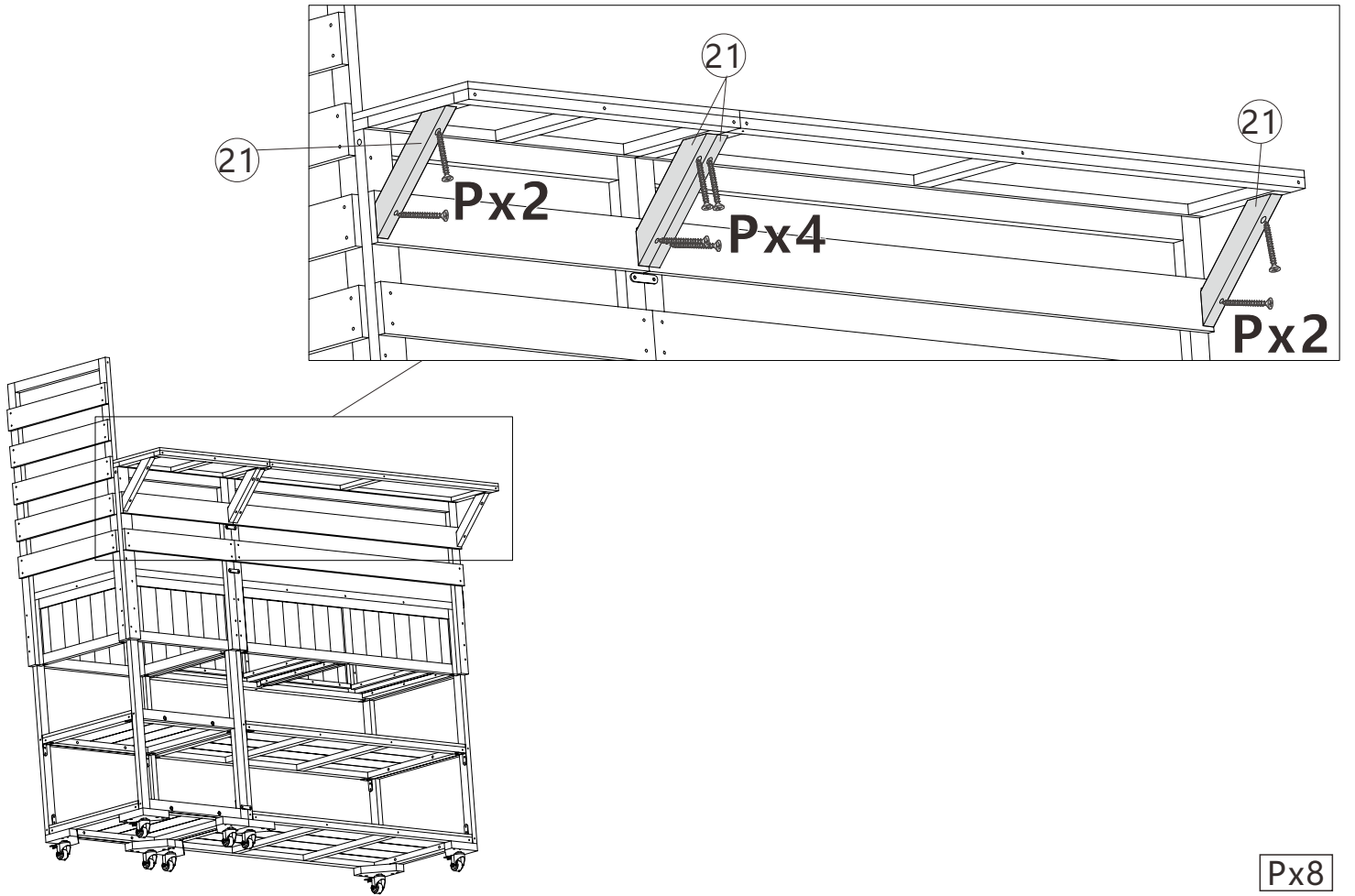

45

Px8
 (21) x4

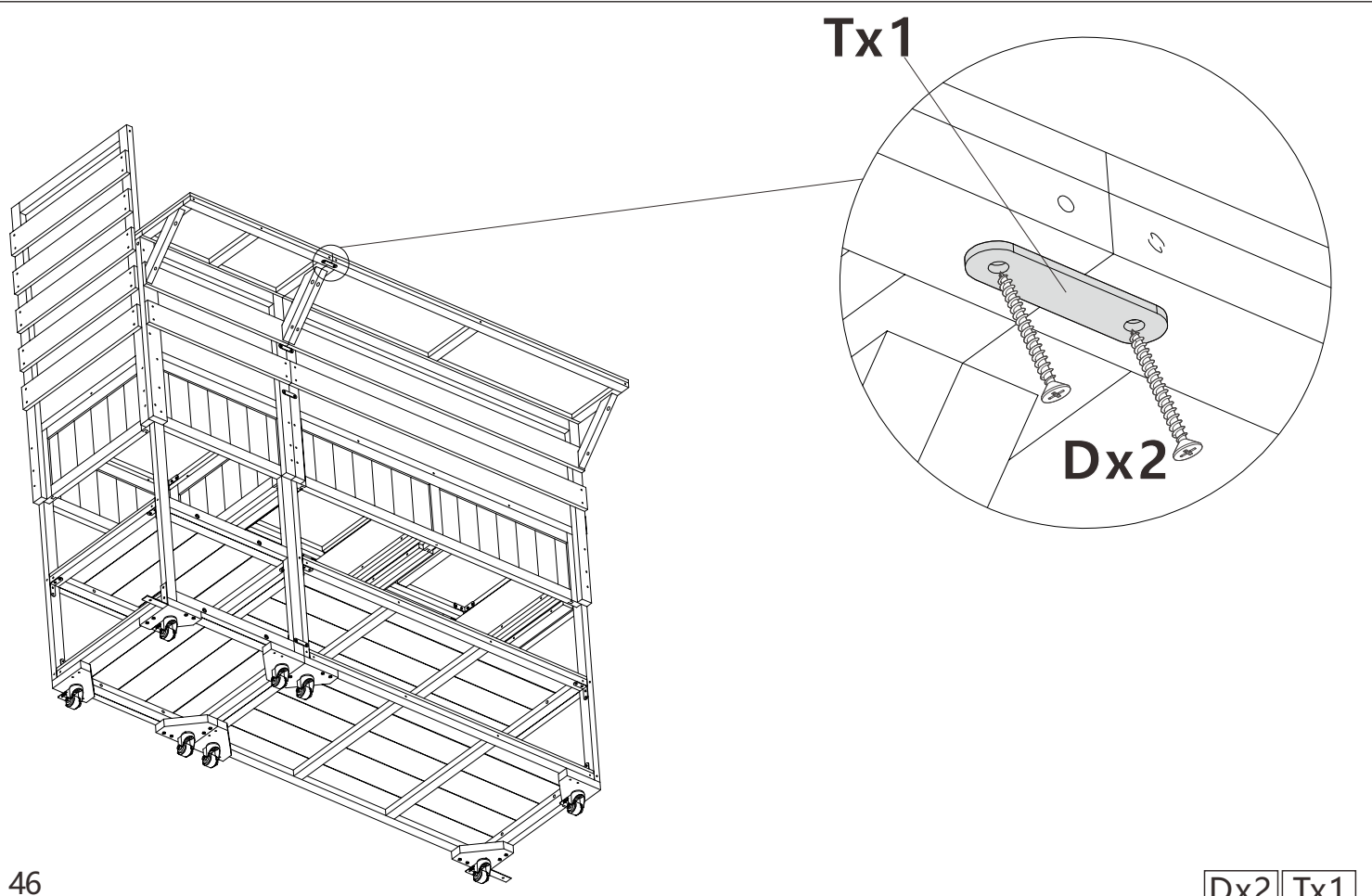

46

Dx2 Tx1

Remove 4 wheels firstly, then assembly L shape metal and nails.
 Retirez 4 roues tout d'abord, puis assemblage en forme de L métal et clous

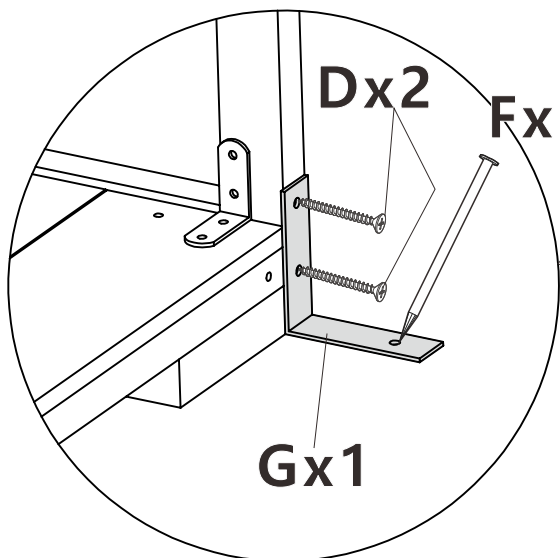
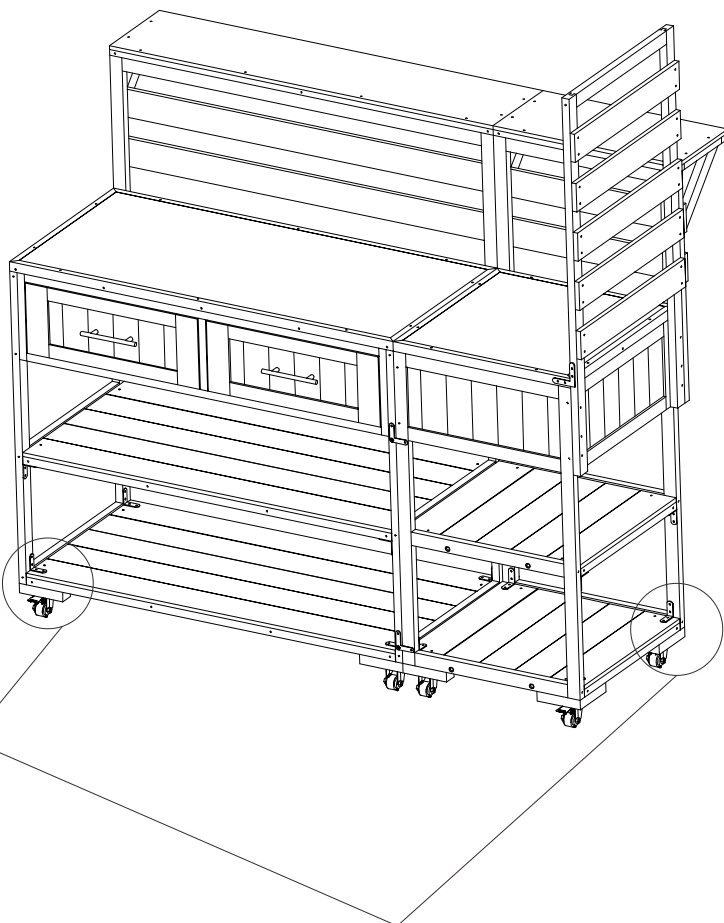

47

Dx4 Fx2 Gx2

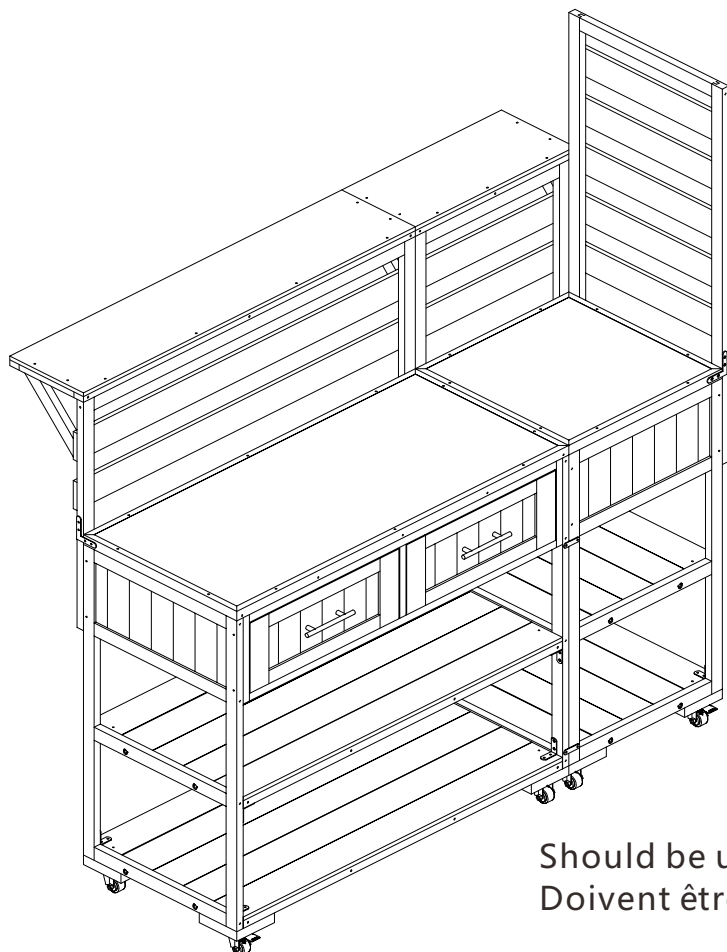

Should be used together and not separately
 Doivent être utilisés ensemble et non séparément

48