

# NOTICE

- \* Please make sure that you have all parts indicated and they are in good condition before you begin assembly of this item. Refer to part list and hardware list below for guidance.
- \* This item should be assembled on a soft surface to prevent scratching the finish during assembly.
- \* This item may require periodic tightening.
- \* If you are having difficulty, our friendly Customer Care team is always here to help. Please email



# PREPARATION

- \* Before beginning assembly of product, make sure all parts are present. Compare parts with part contents list and hardware contents list.
- \* If any part is missing or damaged, do not attempt to assemble the product.
- \* Estimated Assembly Time: **60 minutes**.
- \* Tools Required for Assembly (included): **Allen Key**.

# CARE AND MAINTENANCE

Store outdoor furniture indoors or cover well when not in use. Remove wooden furniture from standing water. Dust regularly with small brush or vacuum. Spills should be taken care of immediately before they harden or stain with a slightly dampened sponge. Do not use bleach solutions

## Part List and Hardware List

PIECE	DESCRIPTION	PICTURE	QUANTITY
1	Top Table Wooden		1X
2	Leg Table Frame		2X
3	Support Table Frame		1X
4	Right Frame		3X
5	Left Frame		3X
6	Seat Chair Frame		2X
7	Back Chair Frame		2X
8	Seat Bench Frame		1X
9	Back Bench Frame		1X
CSH1	Seat Chair Cushion		2X
CSH2	Seat Bench Cushion		1X
CSH3	Back Cushion		4X
HW1	Allen Bolt: M6 x 0.5 x 20 mm		12X
HW2	Allen Bolt: M6 x 0.5 x 30 mm		32X
HW3	Flat Washer: M6 x 1 mm		44X
HW4	Allen Key		2X

Product Dimensions:  
 35.43"x 19.69"x H14.17" (Table)  
 25.20"x 27.56"x H27.16" (Chair)  
 48.03"x 27.56"x H27.16" (Bench)

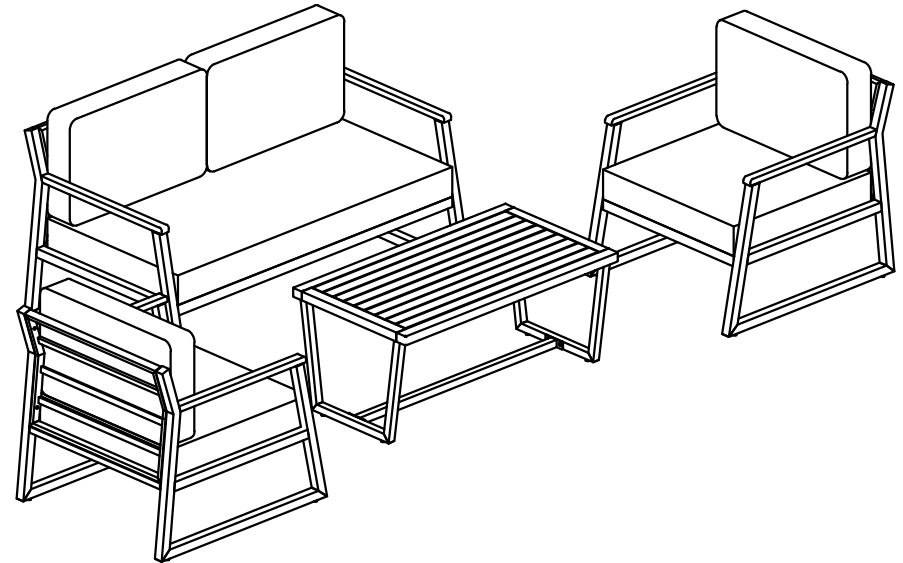

Weight Capacity : 176 lbs ( Table )  
 352 lbs (Single seat )  
 704 lbs (Two person seat )  
 Warning : Do not stand on table/bench, chair  
 Warning : Do not over torque bolts

# PREPARATION

- \* Before beginning assembly of product, make sure all parts are present. Compare parts with part contents list and hardware contents list.
- \* If any part is missing or damaged, do not attempt to assemble the product.
- \* Estimated Assembly Time: **60 minutes.**
- \* Tools Required for Assembly (included): **Allen Key**
- \* If you are having difficulty, our friendly Customer Care team is always here to help. Please email

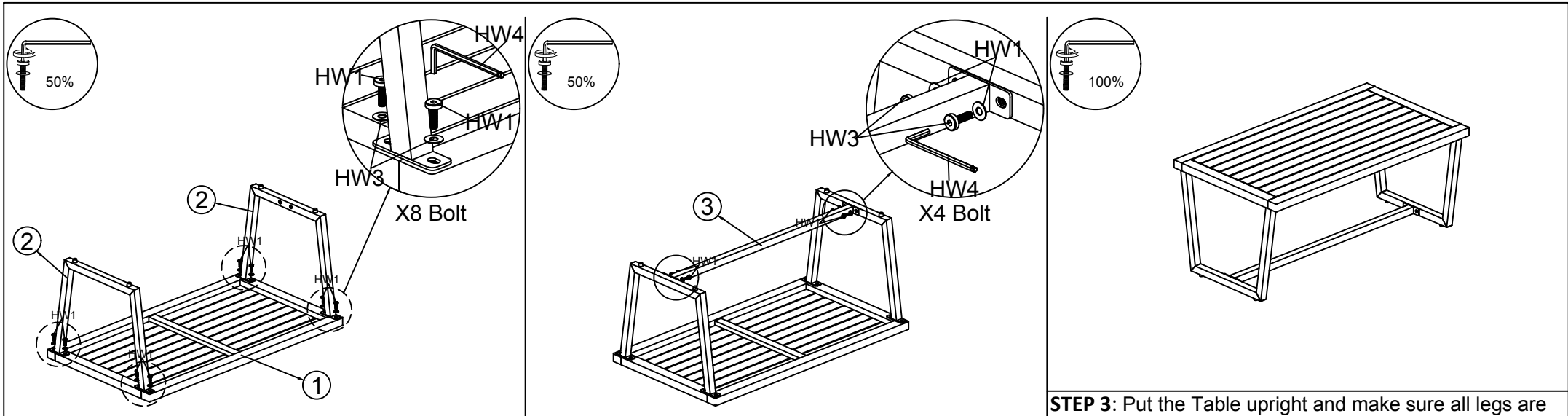

**STEP 1:** Connect Top Table Wooden (1) & Leg Table Frame (2), tighten Bolt (HW1), Flat Washer (HW5) with Allen Key (HW6).

**STEP 2:** Connect The Part from STEP 1 & Support Table Frame (3), tighten Bolt (HW1), Flat Washer (HW3) with Allen Key (HW4).

**STEP 3:** Put the Table upright and make sure all legs are level, then firmly tighten bolts with Allen Key (HW4), to finish Table.

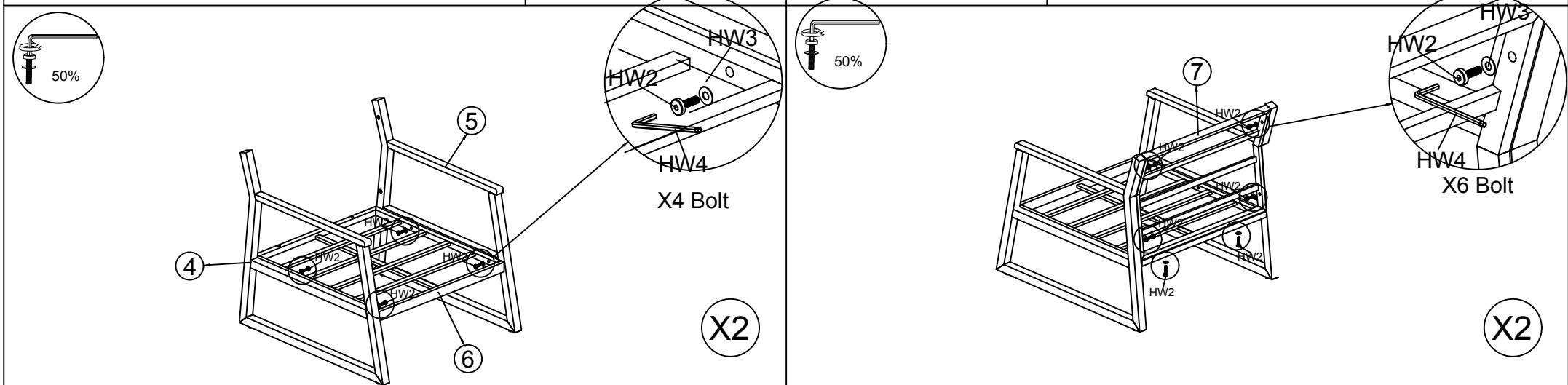

**STEP 4:** Connect Seat Chair Frame (6) & Right Frame (5), Left Frame (4), tighten Bolt (HW2), Flat Washer (HW3) with Allen Key (HW4).

**STEP 5:** Connect The Part from STEP 4 & Back Chair Frame (7), tighten Bolt (HW2), Flat Washer (HW3) with Allen Key (HW4).

# PREPARATION

- \* Before beginning assembly of product, make sure all parts are present. Compare parts with part contents list and hardware contents list.
- \* If any part is missing or damaged, do not attempt to assemble the product.
- \* Estimated Assembly Time: **60 minutes.**
- \* Tools Required for Assembly (included): **Allen Key**
- \* If you are having difficulty, our friendly Customer Care team is always here to help. Please email

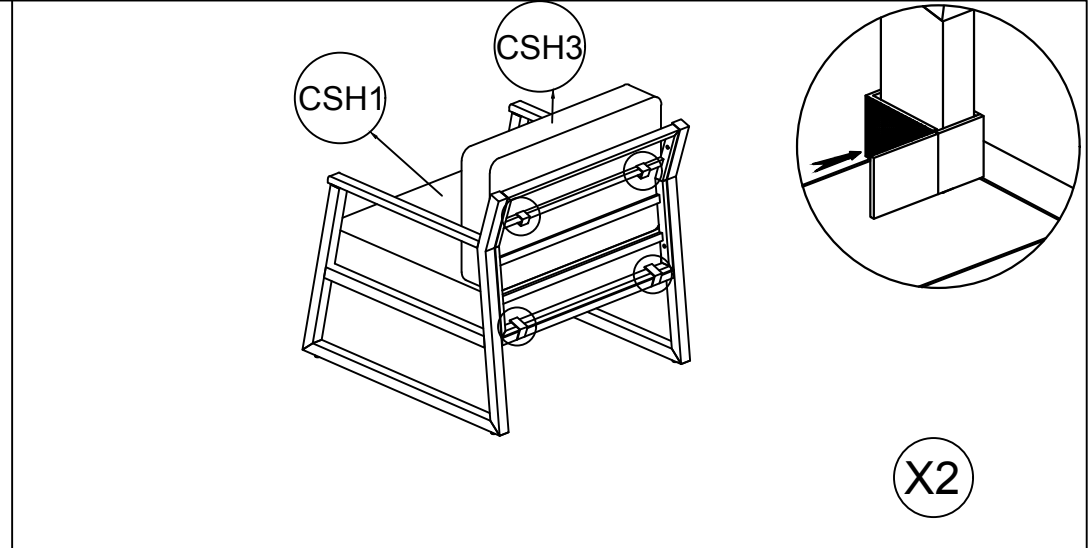
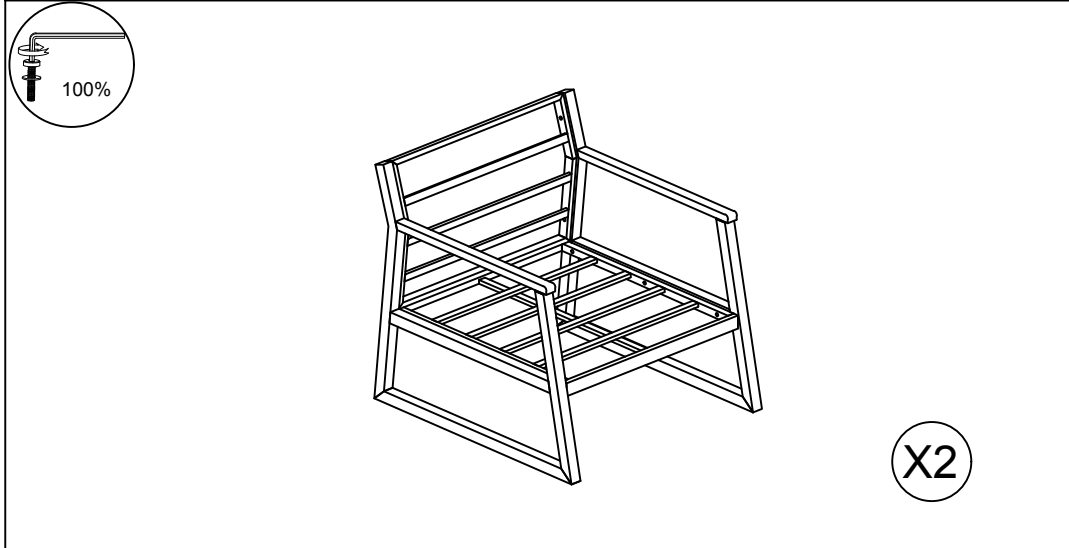

**STEP 6:** Put the Chair upright and make sure all legs are level, then firmly tighten bolts with Allen Key (HW4), to finish Chair.

**STEP 7:** Put on Seat Chair Cushion (CSH1) & Back Cushion (CSH3), to Chair . Stick string to Back Chair & Seat Chair to finish Chair.

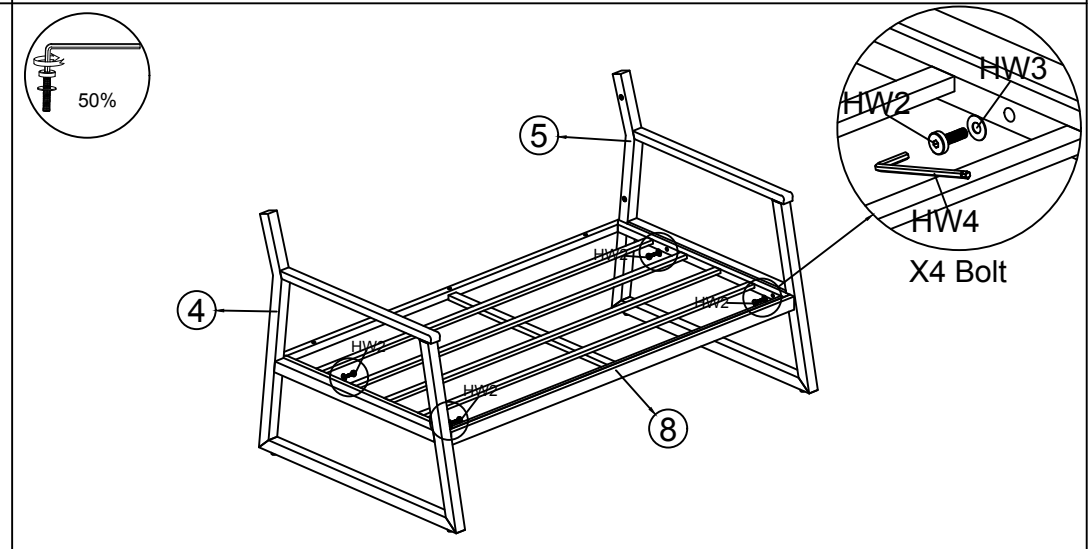
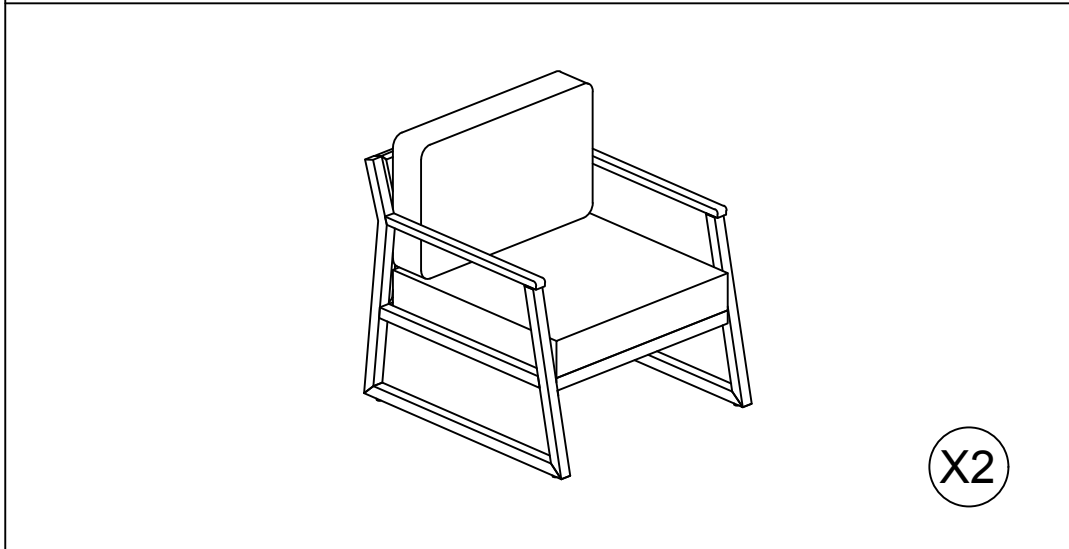

**FINISH CHAIR**

**STEP 8:** Connect Seat Bench Frame (8) & Right Frame (4), Left Frame (5), tighten Bolt (HW1), Flat Washer (HW3) with Allen Key (HW4).

# PREPARATION

- \* Before beginning assembly of product, make sure all parts are present. Compare parts with part contents list and hardware contents list.
- \* If any part is missing or damaged, do not attempt to assemble the product.
- \* Estimated Assembly Time: **60 minutes**.
- \* Tools Required for Assembly (included): **Allen Key**
- \* If you are having difficulty, our friendly Customer Care team is always here to help. Please email

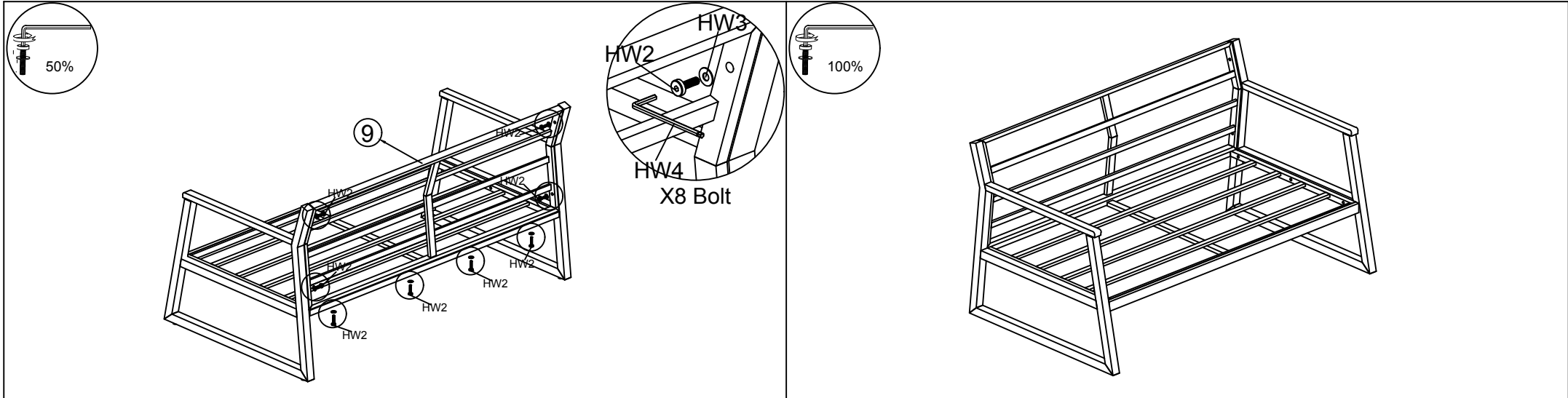

**STEP 9:** Connect The Part from STEP 8 & Back Bench Frame (9), tighten Bolt (HW2), Flat Washer (HW3) with Allen Key (HW4).

**STEP 10:** Put the Bench upright and make sure all legs are level, then firmly tighten bolts with Allen Key (HW4), to finish Bench.

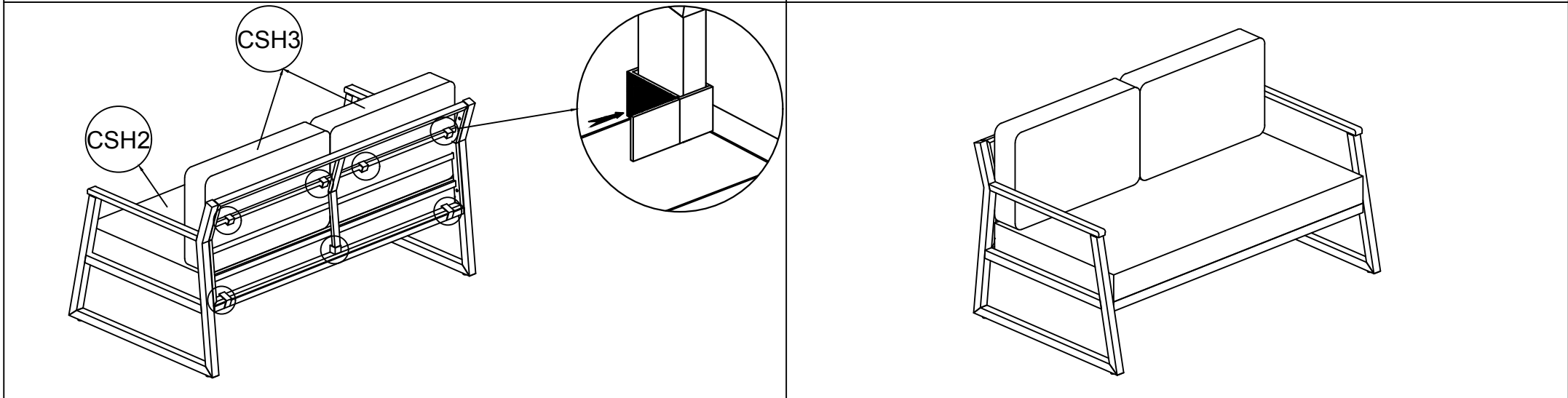

**STEP 11:** Put on Seat Bench Cushion (CSH2) & Back Cushion (CSH3), to Bench . Stick string to Back Bench & Seat Bench to finish Bench

**FINISH BENCH**