

STEP 4

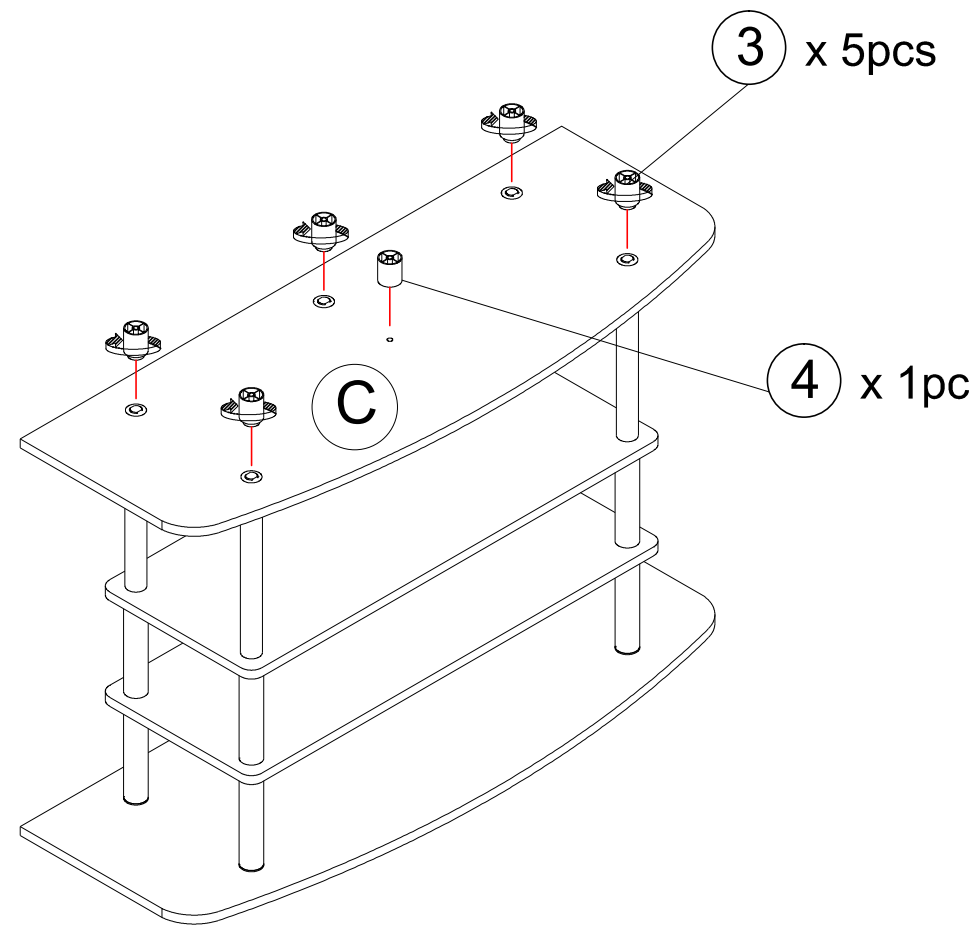

Recommended Maximum Weight

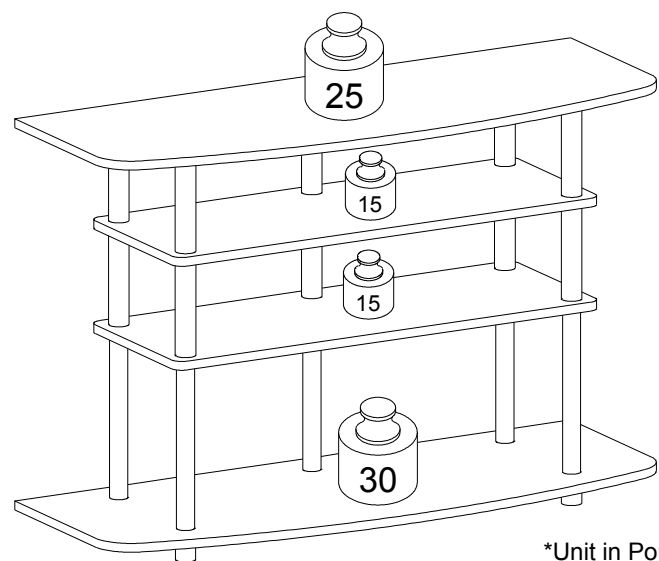

\*Unit in Pound(lbs.)

**WARNING:**

>This unit has been designed to support the maximum loads shown. Exceeding these load limits could cause sagging, instability, product collapse, and/or serious injury.

>DO NOT allow children to climb on unit.

> Put heavier items on lower shelves.

00:15

Approx. 15 minutes



Recomm. 1 Person





No Tools Required

**Assembly Instruction**

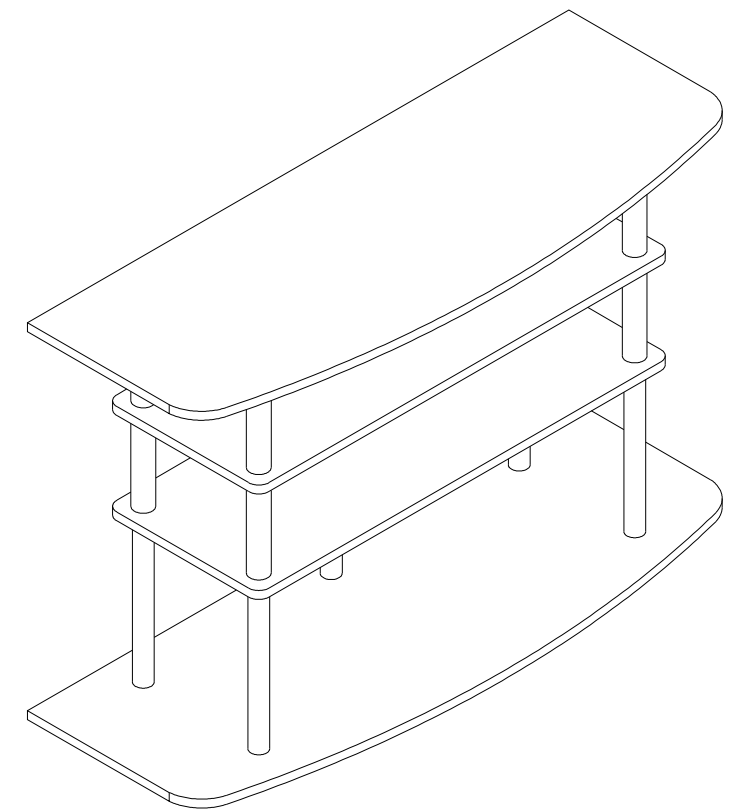
Turn-N-Tube 4-Tier TV Stand

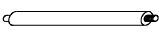
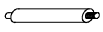

# HARDWARE & PARTS LIST

NO	HARDWARE LIST	QTY
1	METAL LONG POLE 	5pcs
2	METAL SHORT POLE 	10pcs
3	ROUND LEG 	5pcs
4	PLUG LEG 	1pc

NO	PARTS LIST	QTY
A	TOP PANEL	1pc
B	SHELF PANEL	2pcs
C	BOTTOM PANEL	1pc

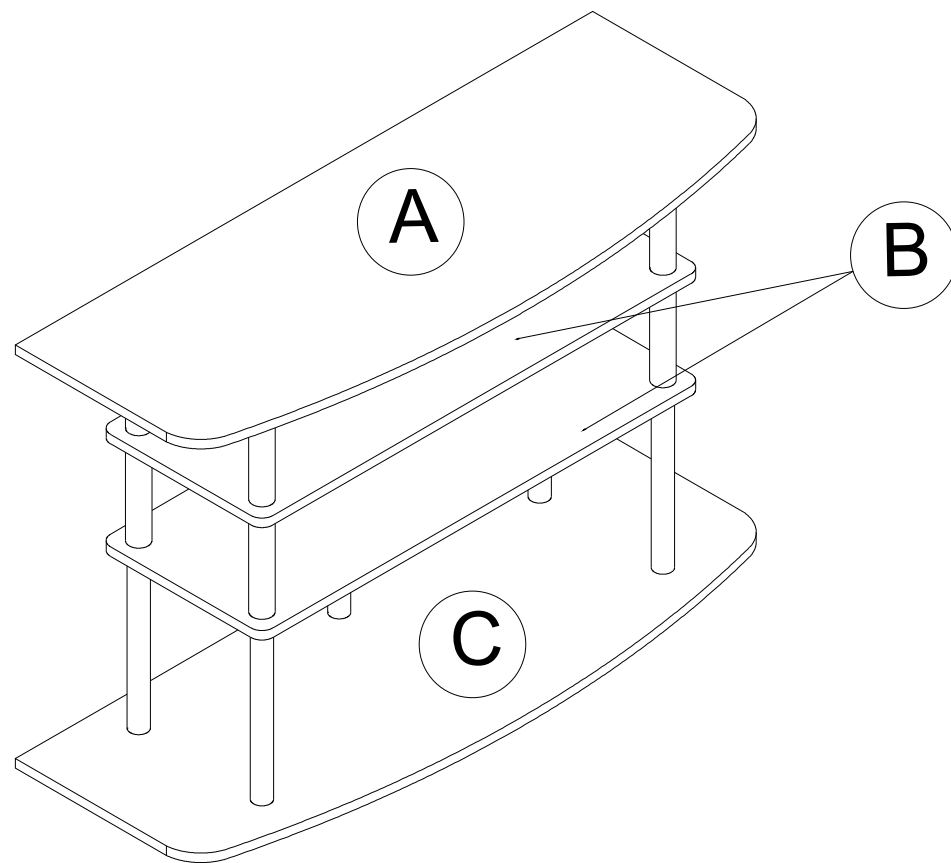

## USEFUL HINTS BEFORE YOU START:

1. Read each step carefully before starting.
2. It is important that each step is performed in correct order to avoid difficulties.
3. Identify, sort and count the parts before assembly.
4. Assemble your furniture on packaging cardboard to prevent scratch or damage.
5. Clean the product with mild cleanser using soft dampened cloth. Do not use harsh or abrasive cleanser.
6. Using incompatible hardware might cause damage to product.

# ASSEMBLY INSTRUCTIONS

BEFORE YOU BEGIN, PLEASE READ ASSEMBLY INSTRUCTION CAREFULLY, FOLLOW THEM STEP BY STEP.

## STEP 1

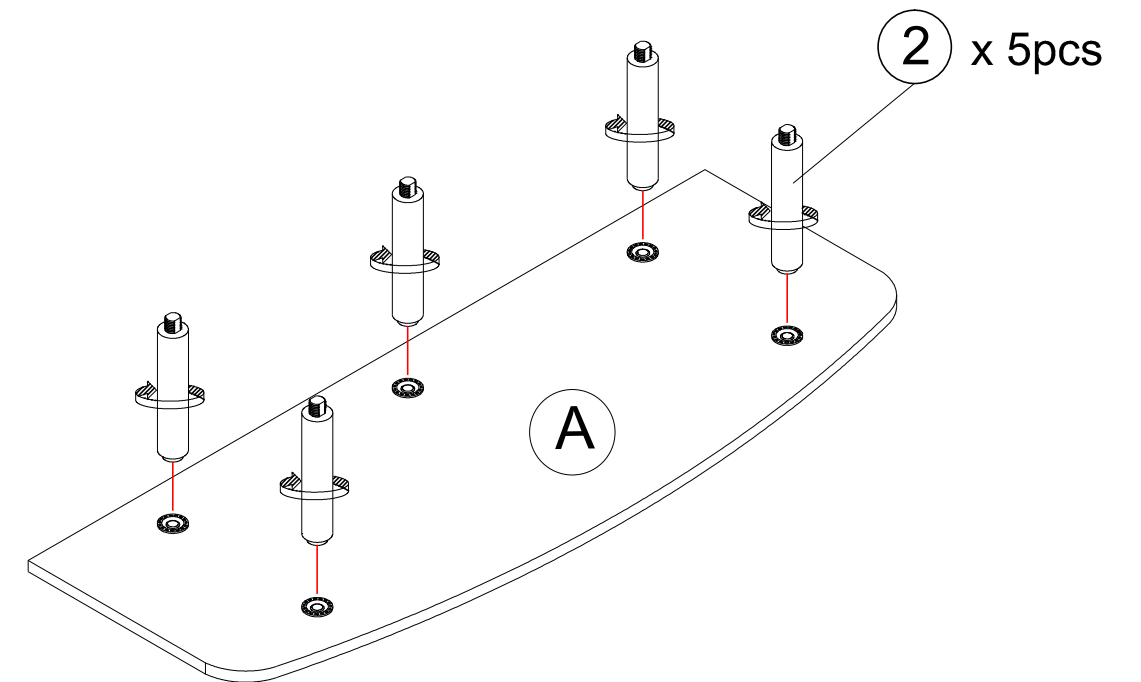

## STEP 2

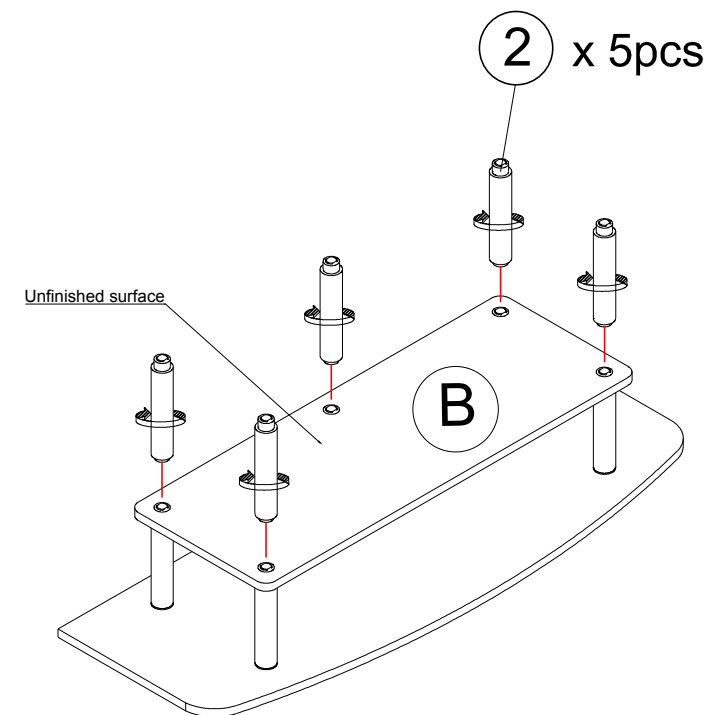

## STEP 3

