

Installation Instruction

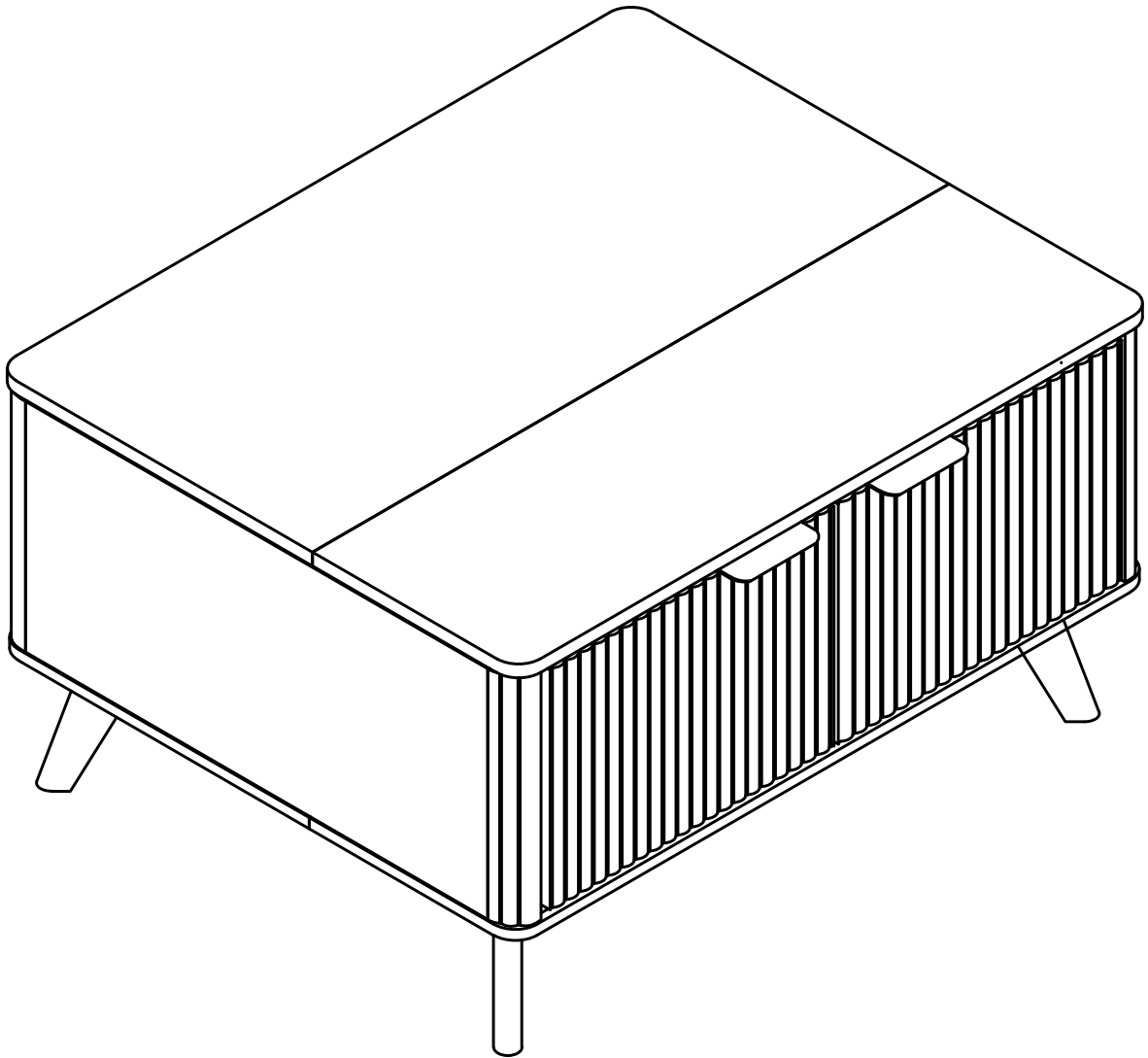

Assembling

What you need

- Use the packaging carton as a working surface to prevent product damage during assembly
- Phillips head screwdriver

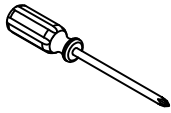

Weight Limitation

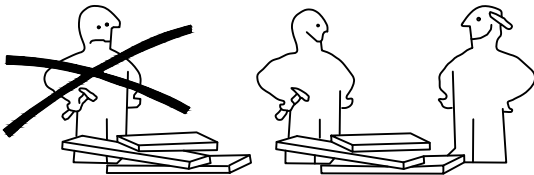

What' included

Code	Description	Qty
A	Cam Bolt M6X35MM	10
B	Cam Lock 15X10MM	10
C	Wooden Dowel M6X30MM	16
D	Screw M4X40MM	11
E	Metal shake handhandle	2
F	Cam Bolt M7X40MM	8
G	Stopper	1
H	Screw M3.5X12MM	48
I	Hole position sticjer	10
J	The screw M6x25	14
K	Wooden Dowel M8X30MM	4
L	MATS	4
M	Wrench M4X55MM	1
N	Hinge	4
O	Reinforced Iron Sheet	2
P	Screw M3.5X12MM	8
Q	Left regulator	1
R	Right regulator	1
S	Screw M3.0X12MM	4

The Hardwares

(A)

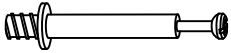

(B)



(C)

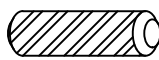

(D)

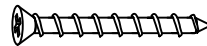

(E)

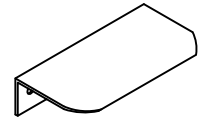

(F)



(G)

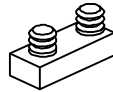

(H)



(I)



(J)



(K)

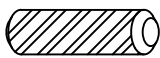

(L)



(M)



(N)

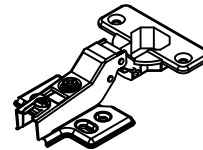

(O)

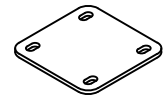

(P)



(Q)

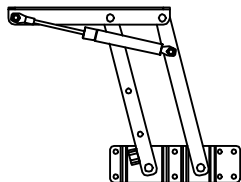

(R)

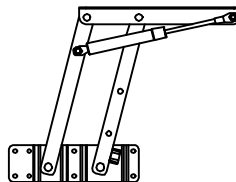

(S)



IMPORTANT:

1. Do not tighten bolts / screws completely until all bolts / screws are lined up and inserted into holes.
2. Do not over tighten screws and bolts to avoid stripping
3. Please use hand tools to assemble this product, you can also use power tools (please use power tools carefully)

Included Accessories

Code	Description	Qty
1	Large Panel	1
2	Small Panel	1
3	Left Side Panel	1
4	Right Side Panel	1
5	Backplane	1
6	Support Plate	1
7	Partition Plate	1
8	Connecting Iron Frame	1
9	Large Base Panel	1
10	Small Base Panel	1
11	Rear Decorative Strip	2
12	Front Decorative Strip	2
13	Wooden Feet	4
14	Left Door	1
15	Right Door	1

The Accessoriess

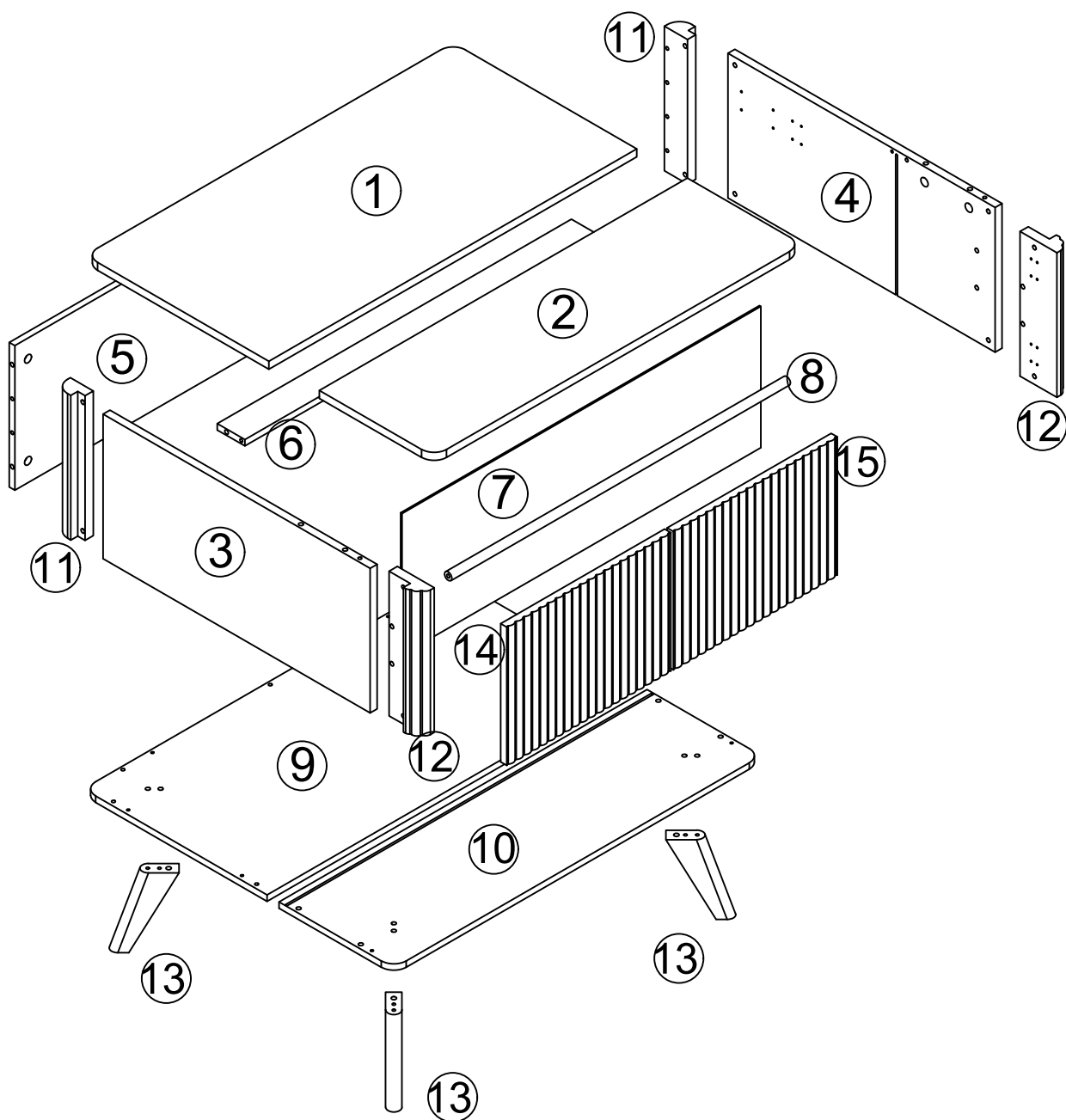

Step 1

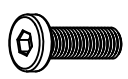
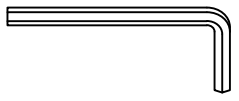
J	x12	M	x1
			

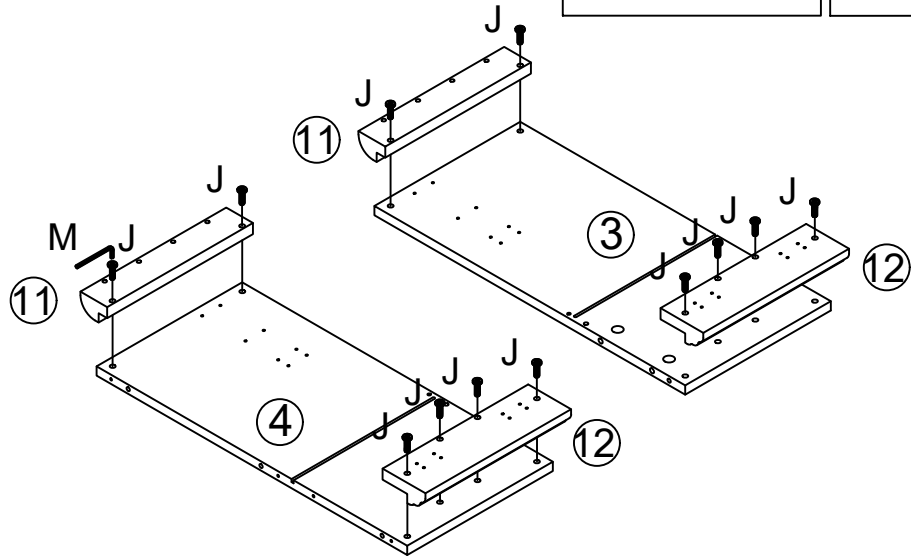
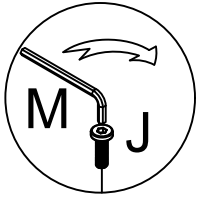

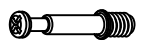

Step 2

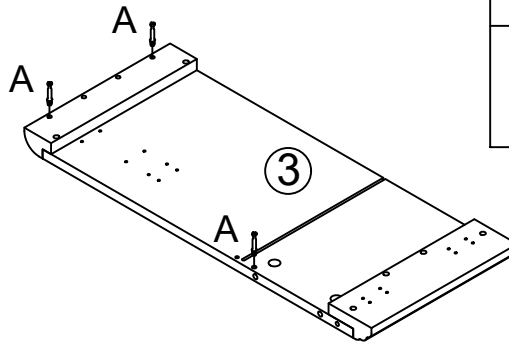
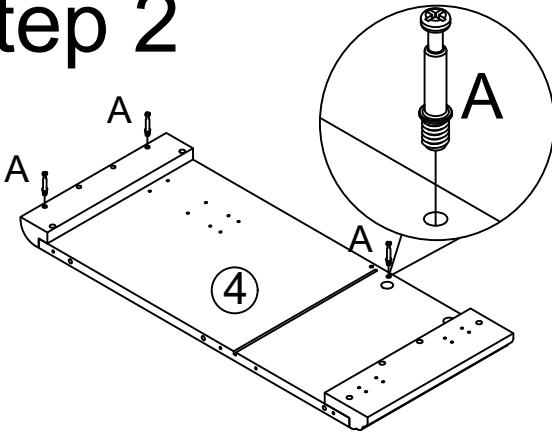
A	x6
	

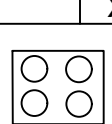

Step 3

I	x6
	

B	x6
	

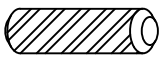
C	x6
	

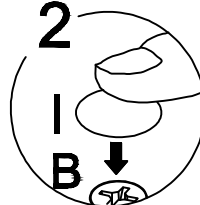
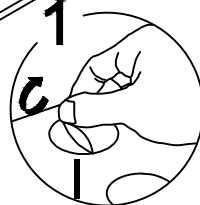
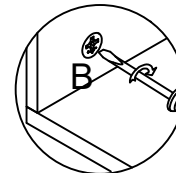
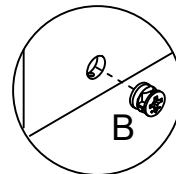
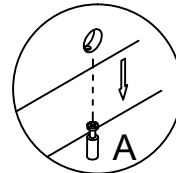
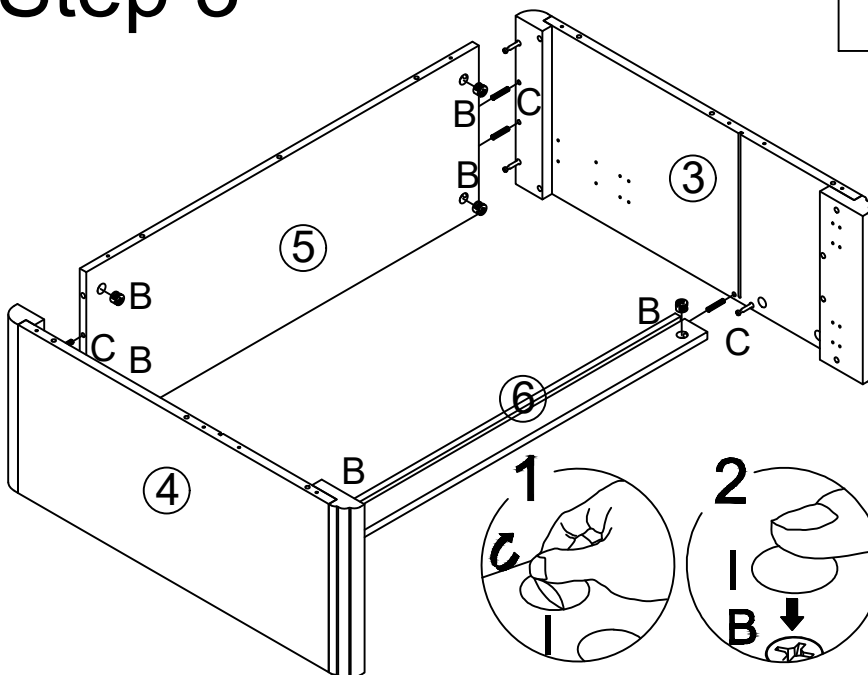

Step 4

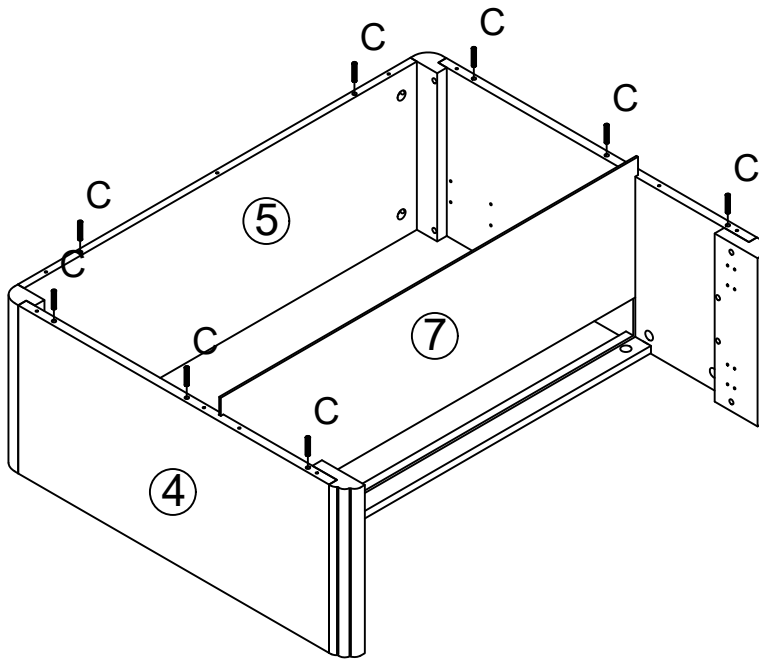
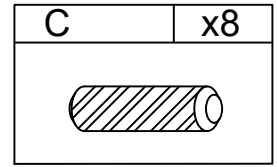

Step 5

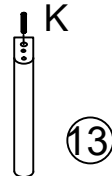
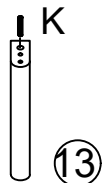
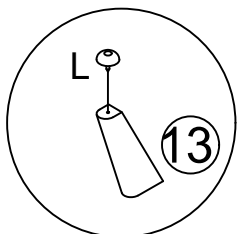
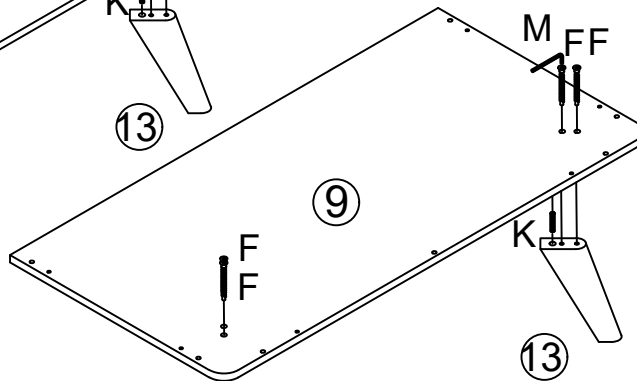
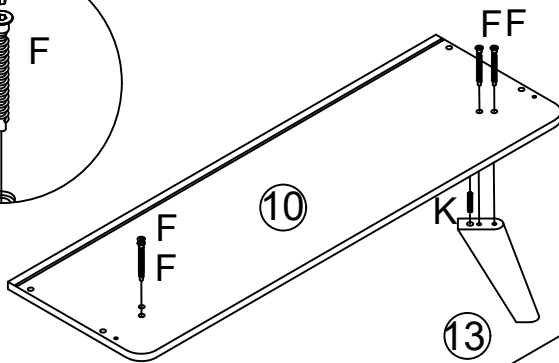
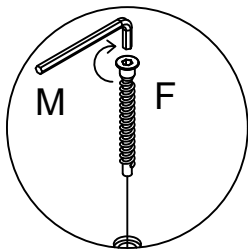
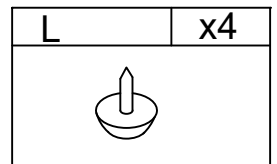
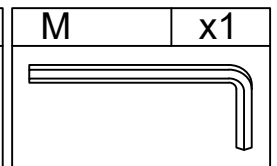
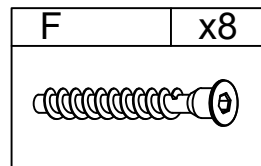
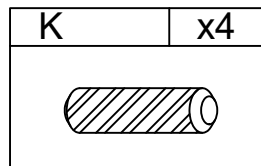

Step 6

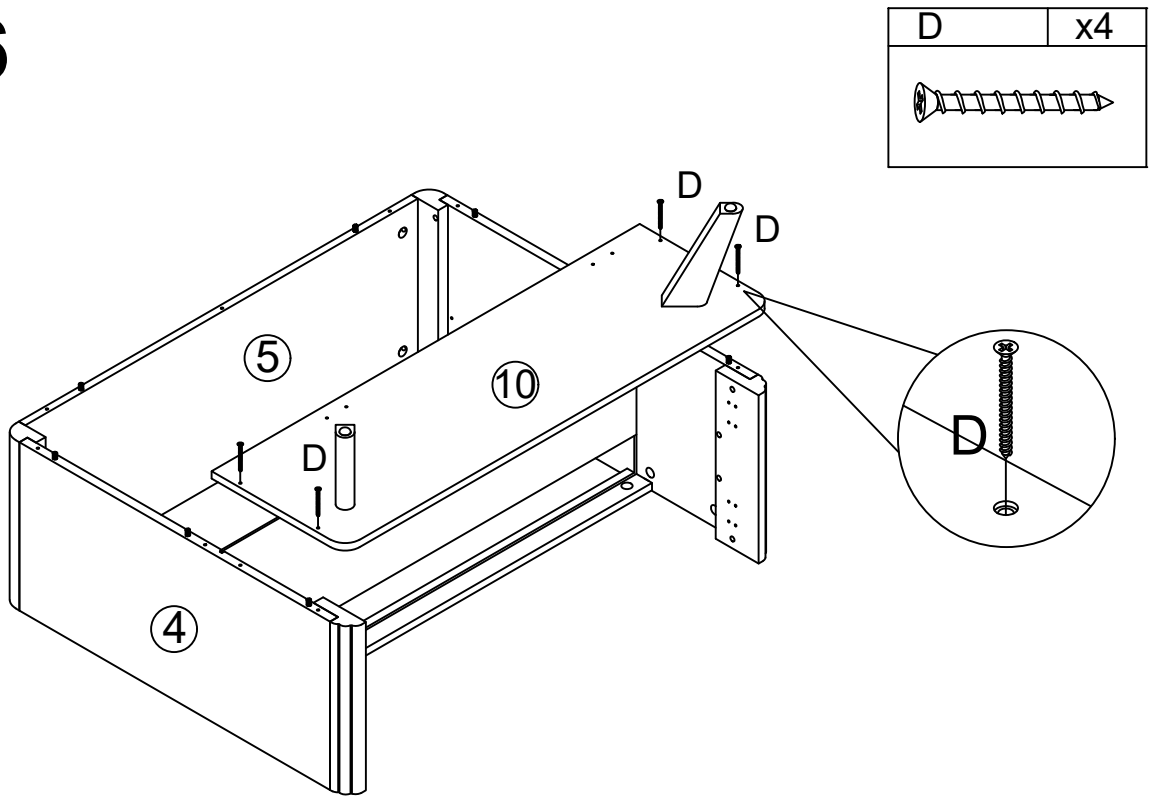

Step 7

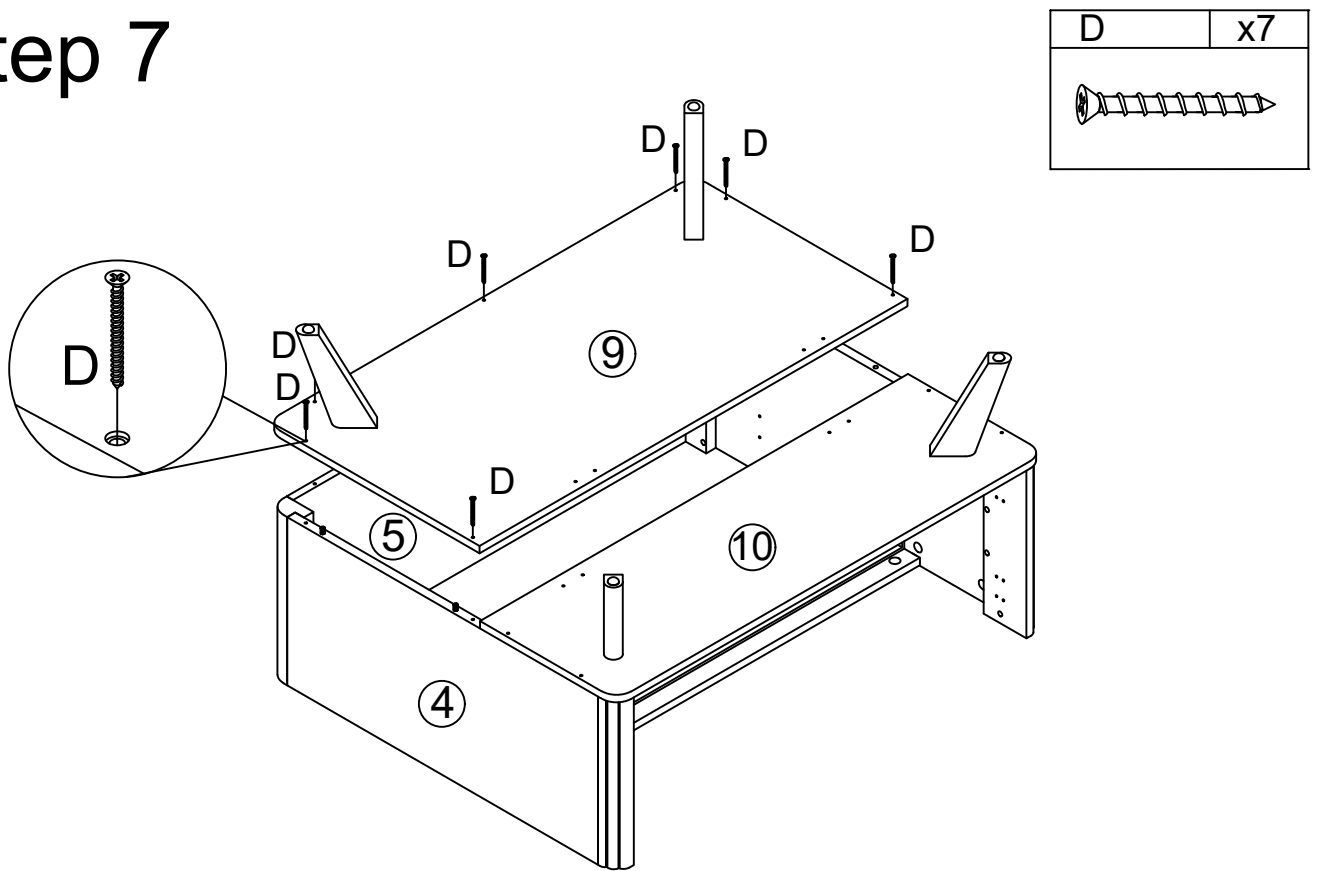

Step 8

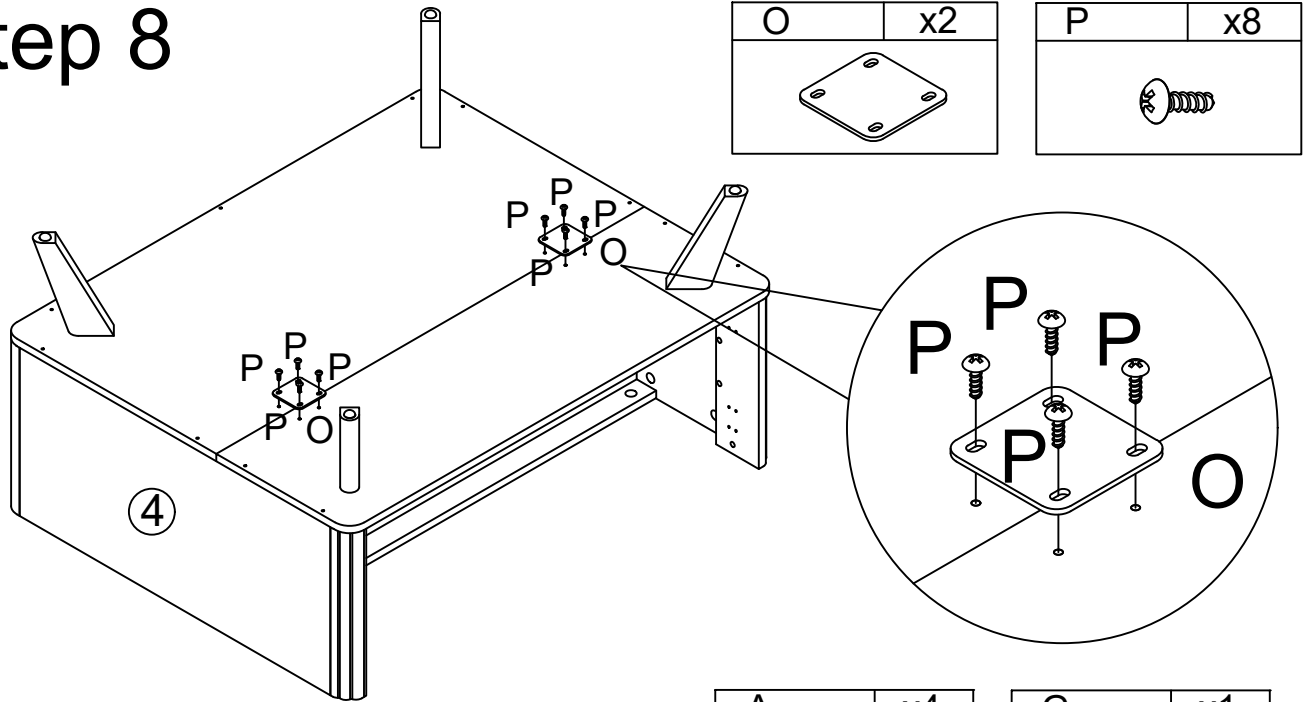

Step 9

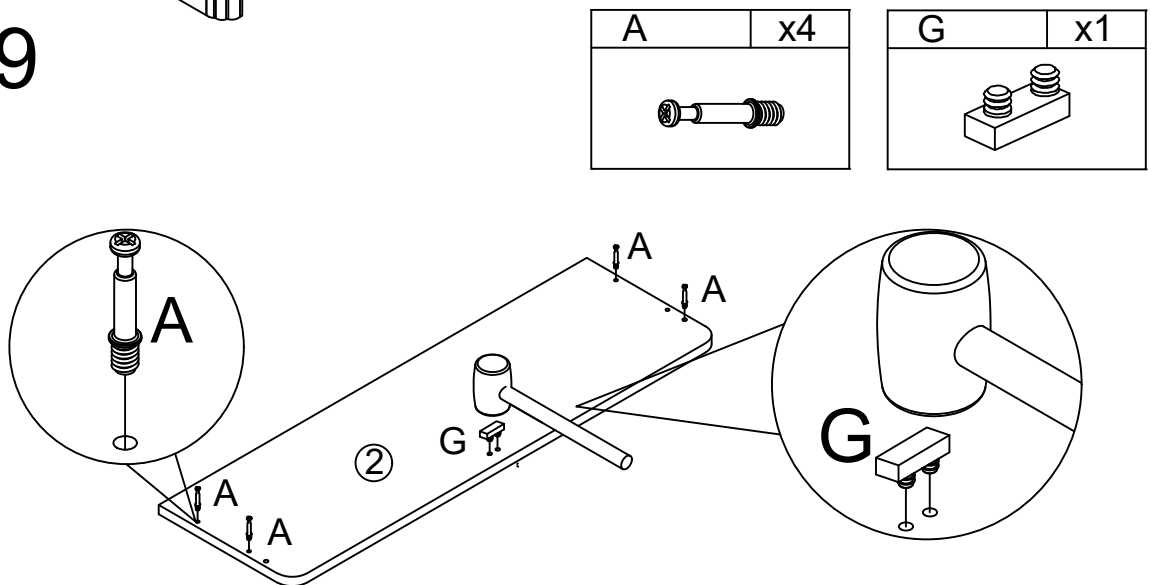

Step 10

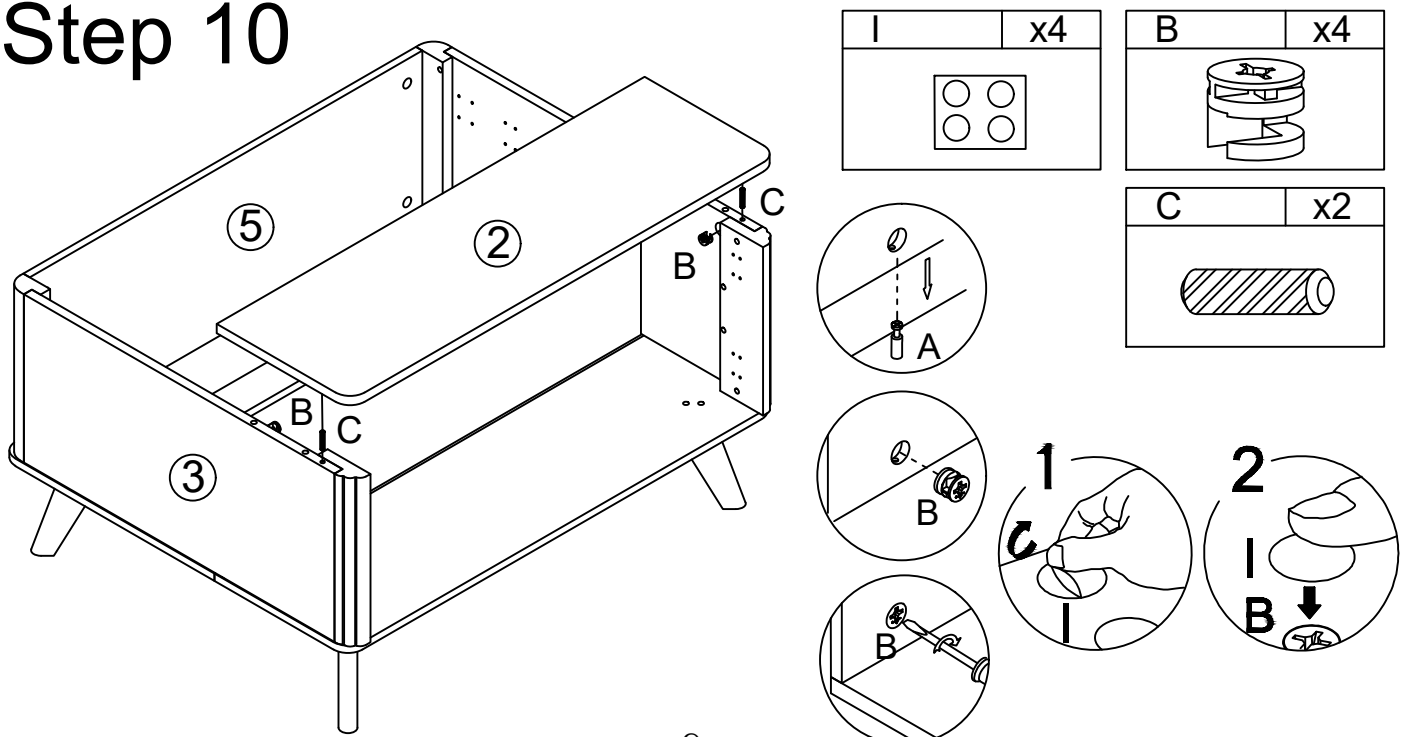

Step 11

H	x 8
	

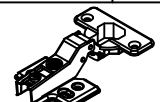
N	x 4
	

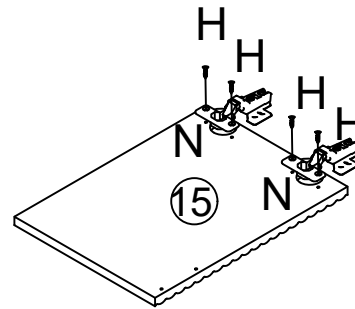
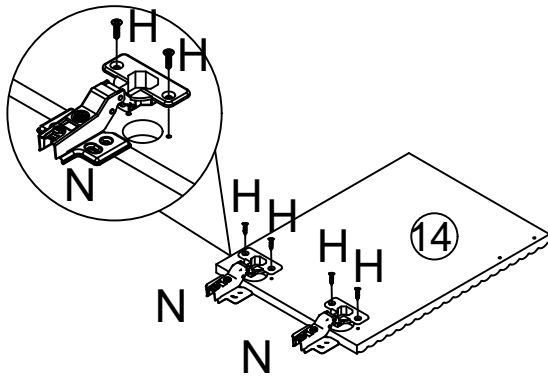

Step 12

H	x16
	

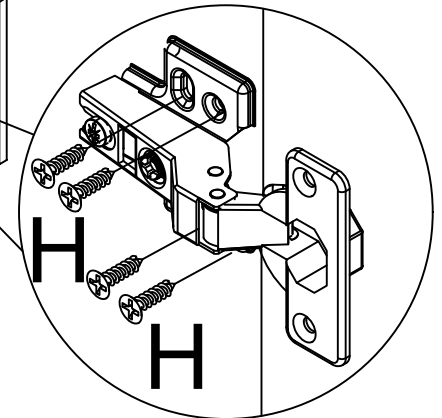
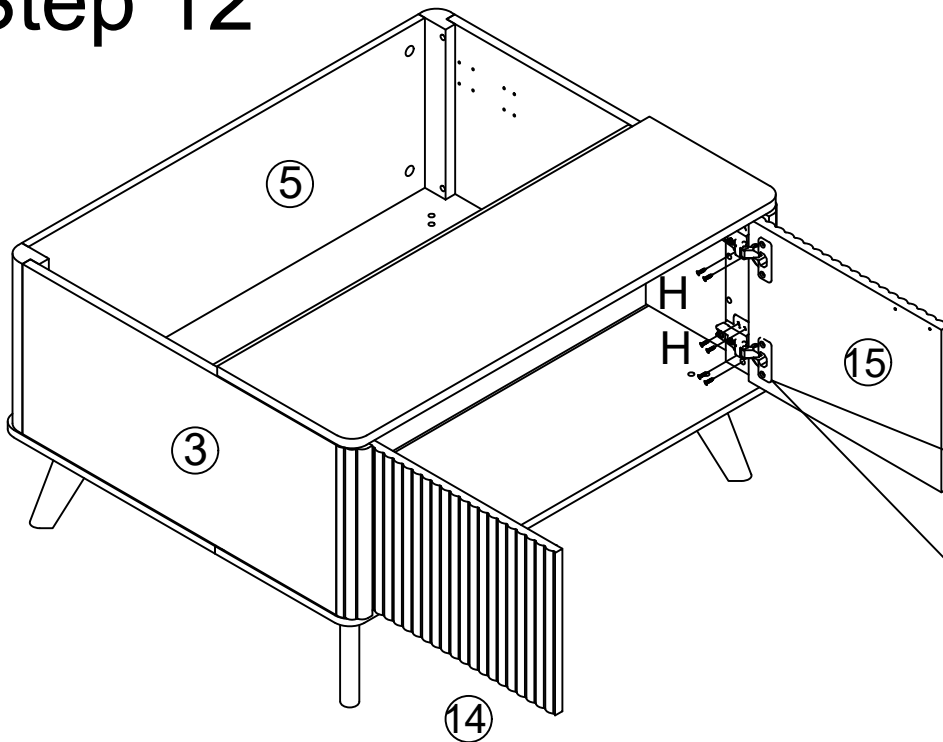

How do I get the two doors to align flat by adjusting the hinges?

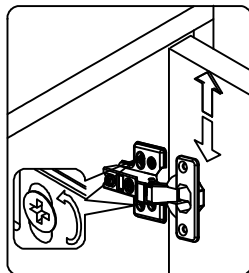

1. Adjust the screws shown in Figure 1 to adjust the doors up and down.

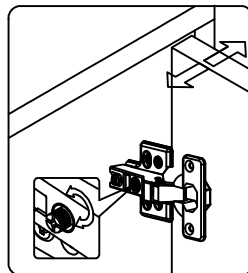

2. Adjust the screws shown in Figure 2 and pull the door back and front so that it can be opened smoothly.

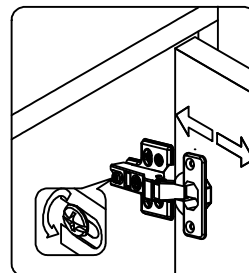

3. Adjust the screws shown in Figure 3 and adjust the door left and right to the right position.

Step 13

S	x4
	

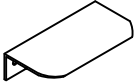
E	x2
	

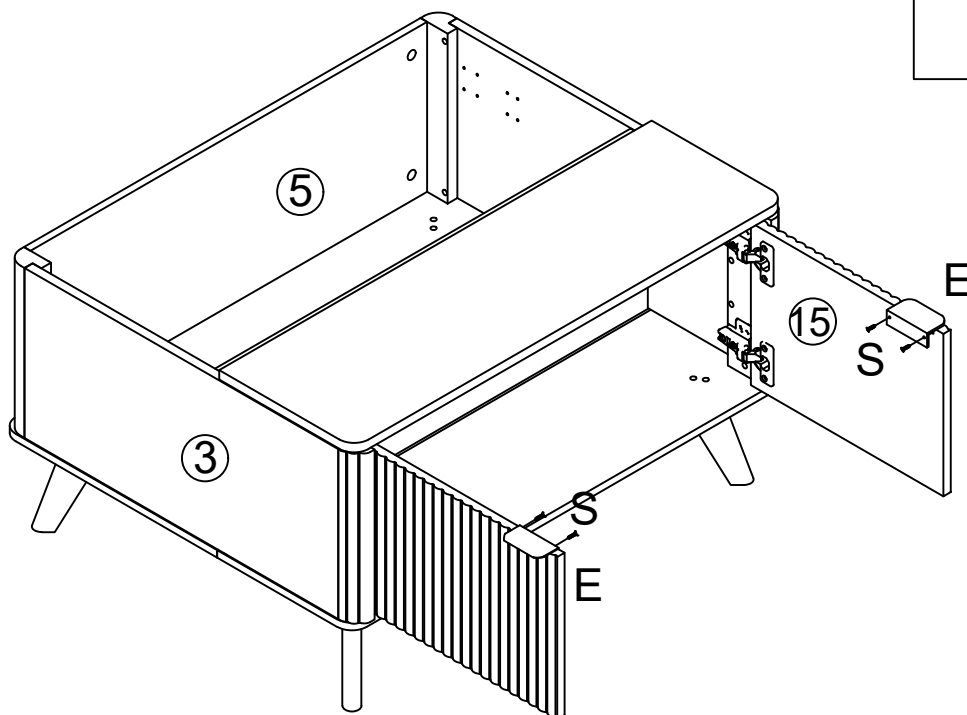

Step 14

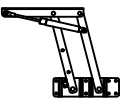

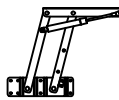
Q	x1
	

R	x1
	

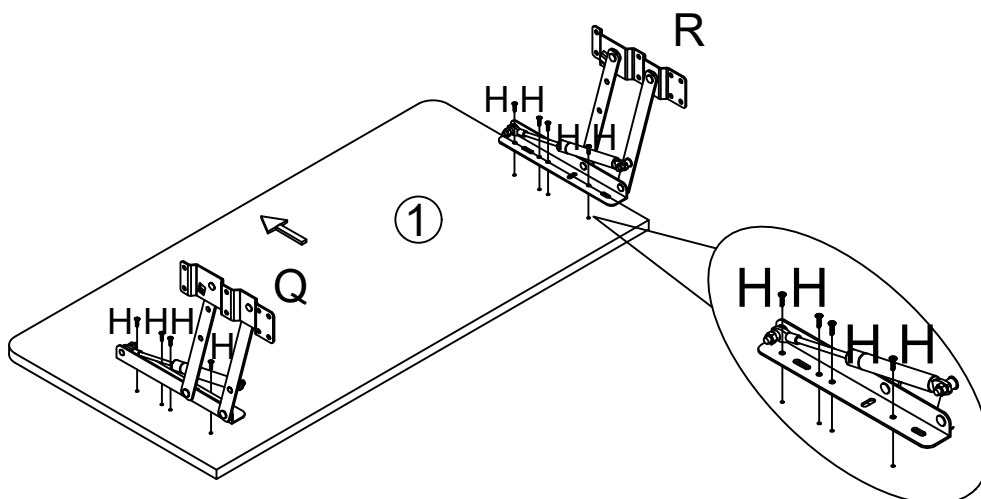
H	x8
	



Step 15

J	x2	M	x1
			

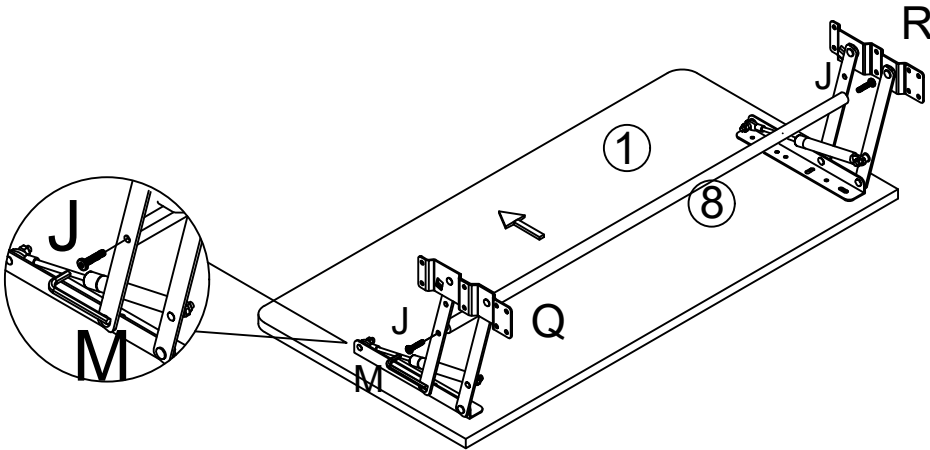

Step 16

H	x16
	

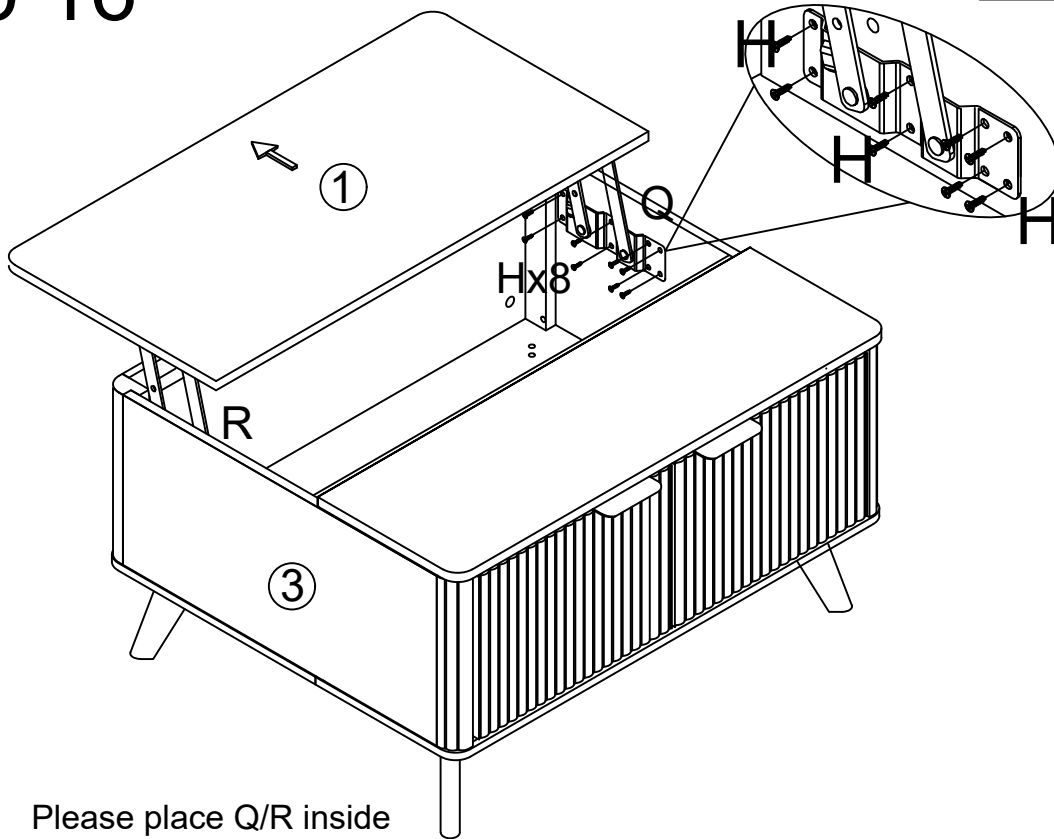

Please place Q/R inside the cabinet at the same time as shown

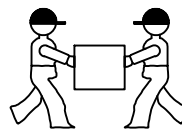

Two people work together to move the table. Make sure you lift it off the ground. Don't push and pull.