

Assembly Instructions

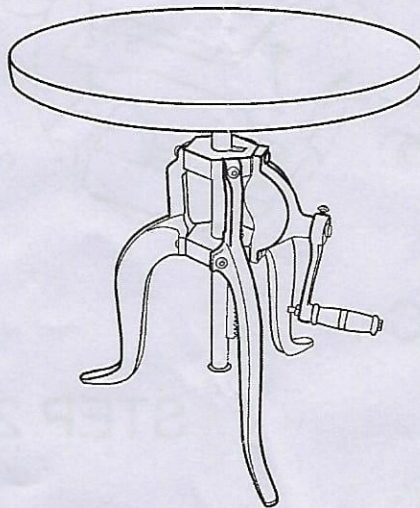





INDUSTRIAL TABLE

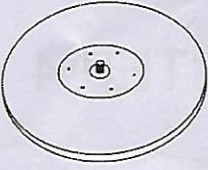

NOTE:
 When attaching leg in Step 1 if the holes do not line up, Loosen the top bolt of the other 2 legs, adjust middle hexagonal piece and then retighten top bolts.
 Do not completely remove bolt of other 2 legs

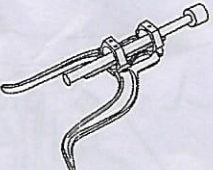

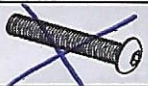
Thank you for purchasing product. This product has been designed for easy assembly and is constructed for durability. Please take the time to read and follow the assembly instructions carefully. If a part or hardware is missing or you have any difficulties in assembling this product, please contact us Toll Free

NO.	PART	DESCRIPTION	Q'TY	NO.	PARTS	DESCRIPTION	Q'TY
A		Top	1PC	B		Leg	1PC
C		Base	1PC	D		Handle	1PC
E		Allen Head Bolt 8mm 15mm	3PCS	F		Allen Head Bolt 8mm 30mm	1PC
G		Allen Head Wrench 5mm	1PC	 Knob			

Assembly Instructions

INDUSTRIAL TABLE

STEP 1

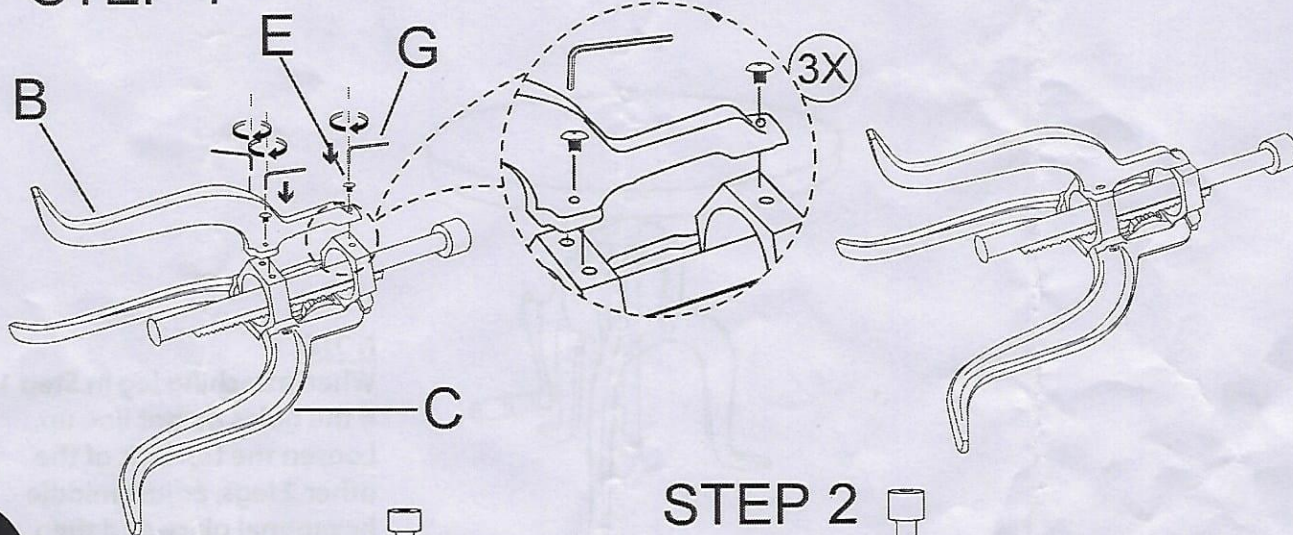

STEP 2

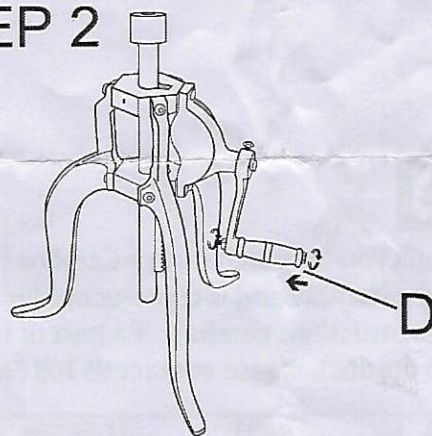

STEP 3

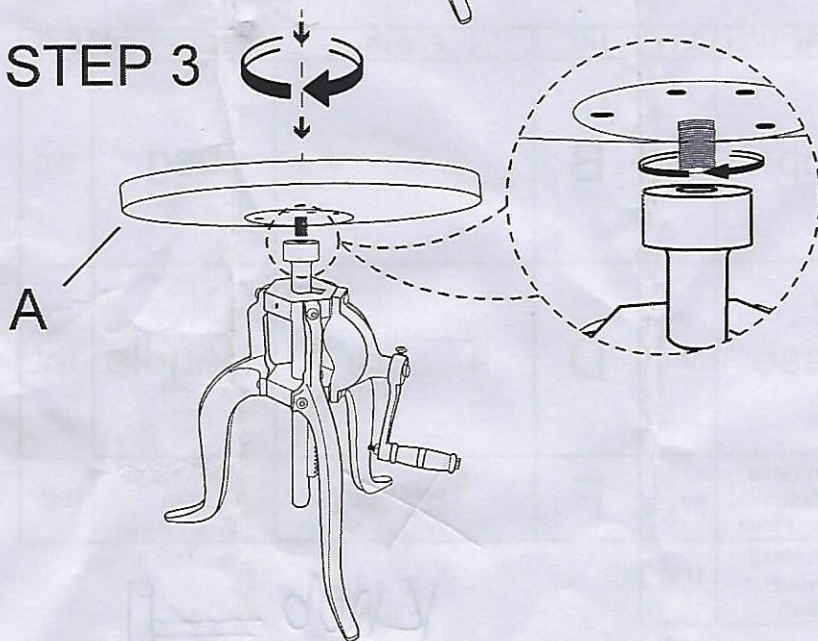

STEP 4

