

# ASSEMBLY INSTRUCTIONS

## WC-2 Shutter Doors

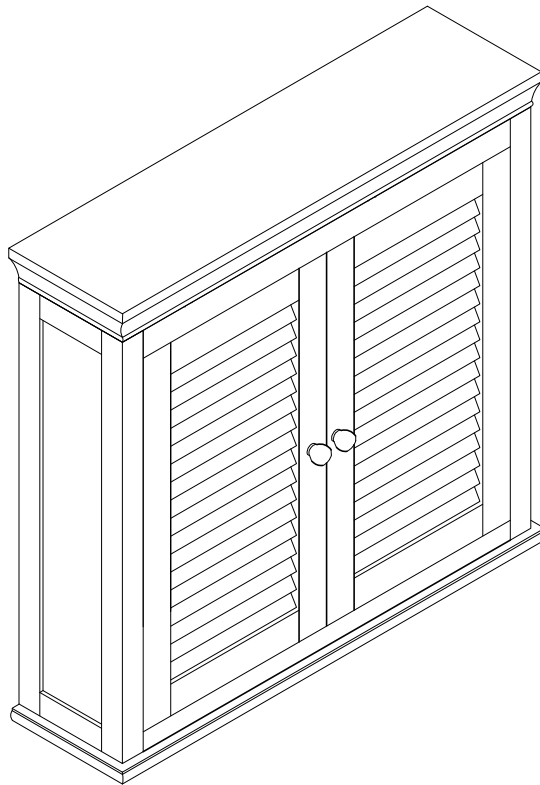

Please provide the following information when contacting for parts or questions: the name of the company you purchased from, the UPS/FedEx tracking number.

### ASSEMBLY INSTRUCTIONS-IMPORTANT

Carefully unpack & identify each component before attempting to assemble. Refer to parts list. Please take care when assembling the unit and always set the parts on a clean, soft surface. If you require any assistance with assembly, parts, please call the company you place order with or please email

### INSTRUCCIONES PARA ARMAR-IMPORANT:







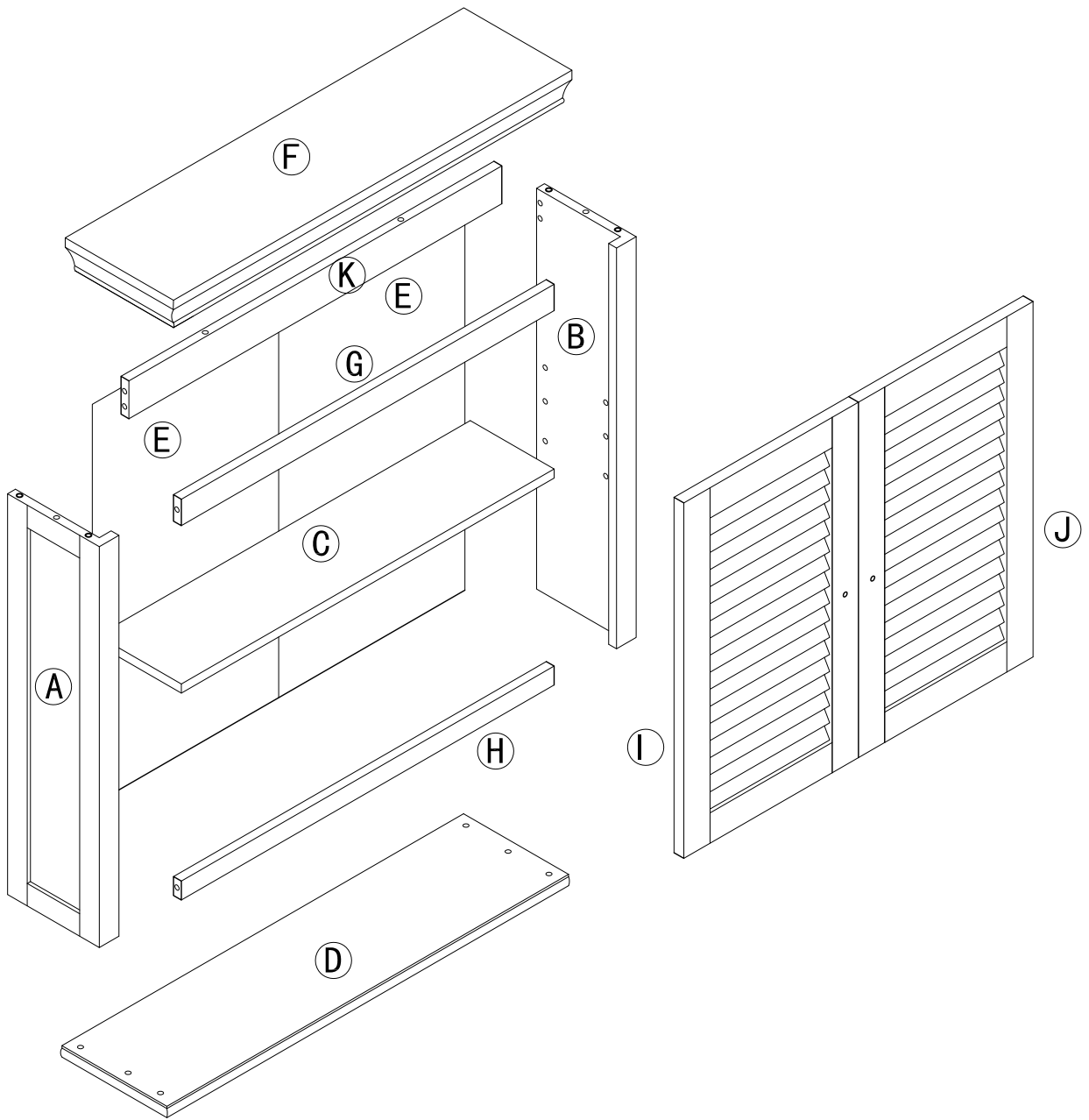



Desempaque cuidadosamente e identifique cada componente antes de tartar de empezar su ensambladura. Verifique la lista de partes. Por favor tenga cuidado cuando arme la unidad y siempre coloque las piezas sobre una superficie plana, suave y limpia. Si necesita ayuda con el armado, envíe un correo electzórico

### DIRECTIVES DE MONTAGE-IMPORTANT:

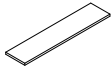

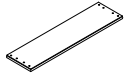



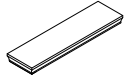



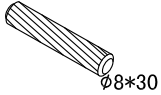

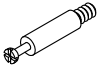
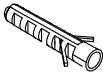
Avant de commencer l' assemblage, déballez délicatement toutes les pièces et repérez-les sur la liste des pièces. Procédez avec soins durant l' assemblage et posez toujours les pièces sur une surface proper, douce et lisse. sie vouo plait e-mail



# COMPONENTS

PART	FIGURE	DESCRIPTION	QTY	PART	FIGURE	DESCRIPTION	QTY
A		LEFT SIDE PANEL	1PC	G		UPPER FRONT RAIL	1PC
B		RIGHT SIDE PANEL	1PC	H		BOTTOM FRONT RAIL	1PC
C		ADJUSTABLE SHELF	1PC	I		LEFT DOOR	1PC
D		BOTTOM PANEL	1PC	J		RIGHT DOOR	1PC
E		BACK PANEL	2PCS	K		UPPER BACK RAIL	1PC
F		TOP PANEL	1PC				

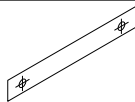
# HARDWARE & TOOLS

PART	FIGURE	DESCRIPTION	QTY	PART	FIGURE	DESCRIPTION	QTY
1	 $\phi 8 \times 30$	WOODEN DOWEL	14PCS	9		PLASTIC BAR	1PC
2		CAM BOLT	8PCS	10		ANCHOR	2PCS
3	 $\phi 15 \times 9$	CAM LOCK	8PCS	11	 $\phi 4 \times 35$	SCREW	2PCS
5	 $\phi 3 \times 12$	SCREW	8PCS	12	 $\phi 3 \times 12 \text{ D}=7$	SCREW	14PCS
6		KNOB	2PCS	13	 $\phi 4 \times 25$	SCREW	1PC
7		KNOB BOLT	2PCS			TEMPLATE PAPER	
8		SHELF PIN	4PCS				

## TOOL NEEDED:



**PHILIPS SCREWDRIVER REQUIRED  
- NOT INCLUDED**

## SUGGESTION:



**TWO PEOPLE FOR ASSEMBLING**



## WARNINGS:

1. DO NOT LET ANY SHARP OBJECTS TOUCH OR RUB THE SURFACE OF THE PRODUCT.
2. WHEN ASSEMBLING, DO NOT LET CHILDREN PLAY AROUND THE WORKING AREA.
3. PLEASE CONFIRM ALL PARTS ARE CORRECT BEFORE STARTING THE ASSEMBLY PROCESS.
4. DO NOT TIGHTEN ALL BOLTS AND SCREWS COMPLETELY UNTIL THE ENTIRE UNIT HAS BEEN ASSEMBLED AND SET UP.

# 1



10 PCS

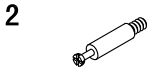

4 PCS



4 PCS

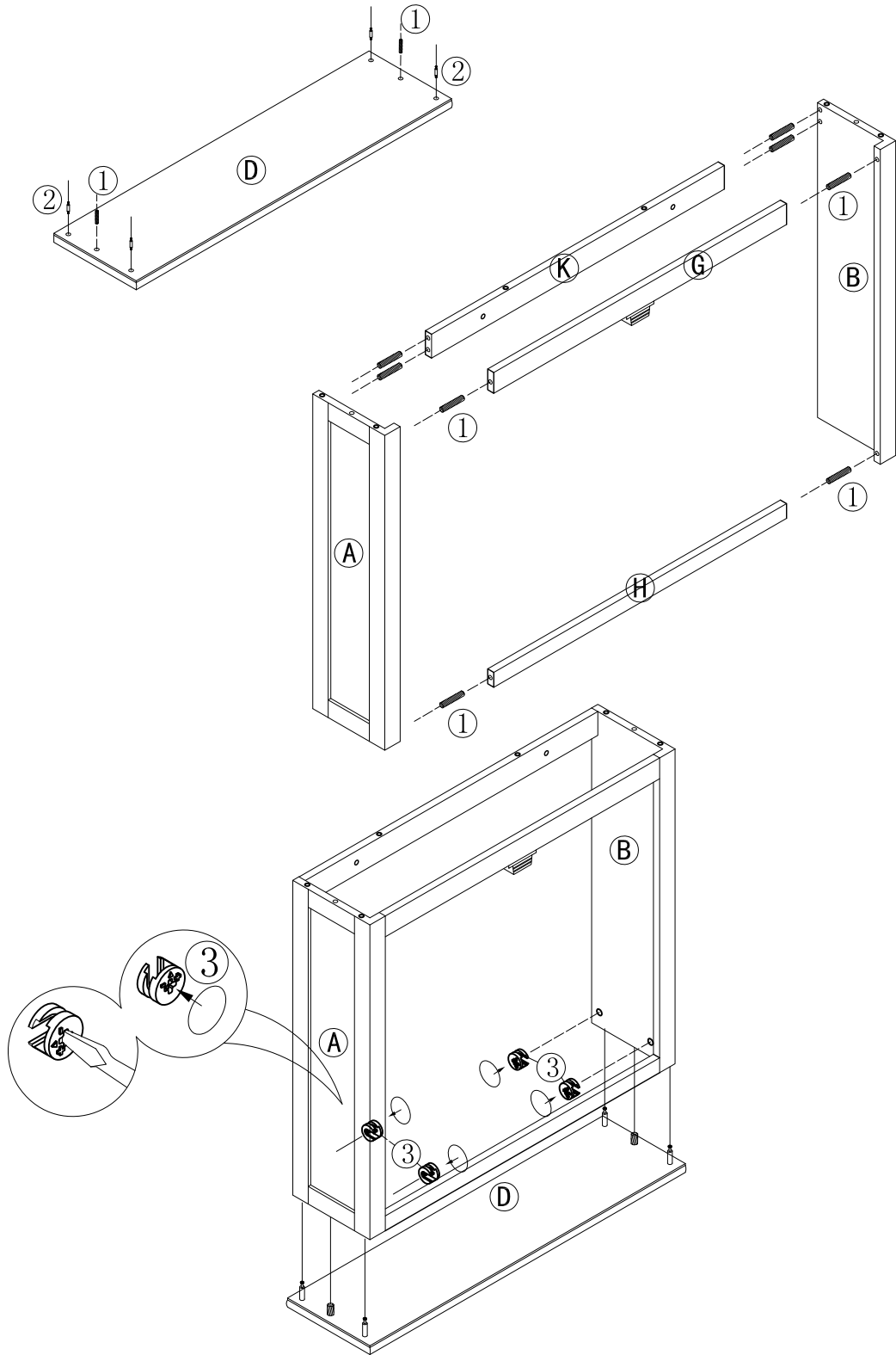

## STEP 1:

1. Screw cambolts (2) and insert dowels (1) to panel D.
2. Attach rails G, H, & K to panels A & B with dowels (1).
3. Attach panel D to panels A & B & secure with camlocks (3).

# 2

1  
4 PCS

2  
4 PCS

3  
4 PCS  $\phi 15 \times 9$

13  
1 PC  $\phi 4 \times 25$

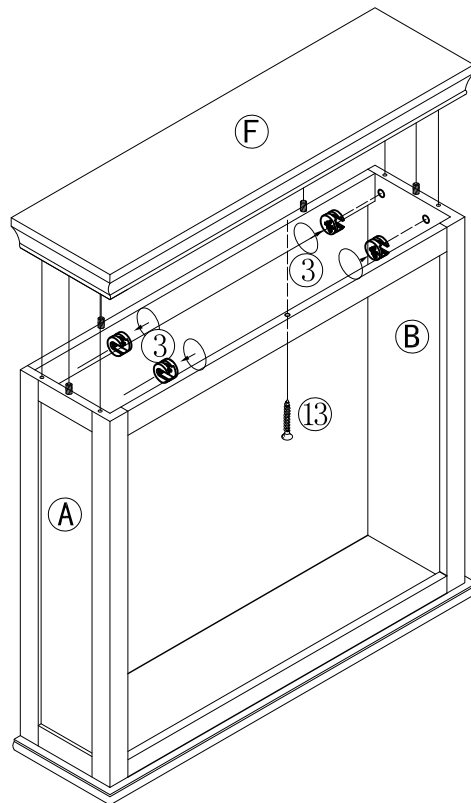
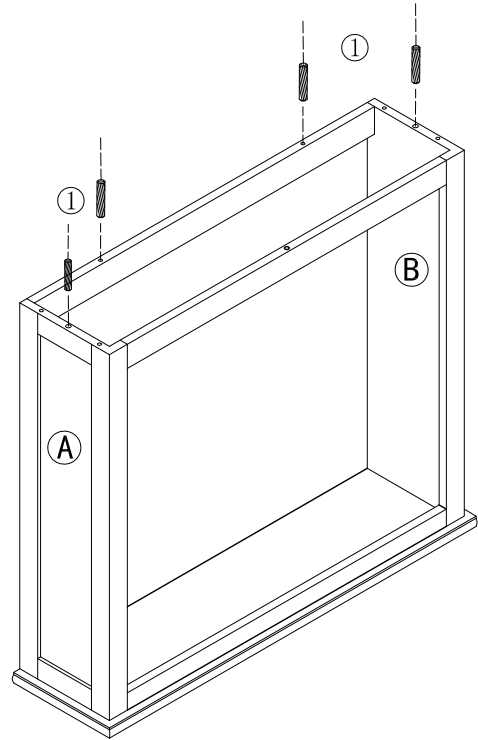
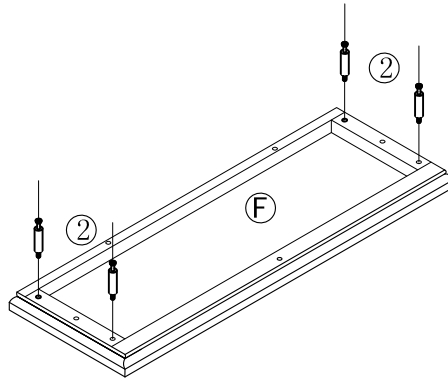

## STEP 2:

1. Screw cambolts (2) to panel F.
2. Insert dowels (1) to the top of panels A & B and rail K.
3. Attach panel F to panels A & B & secure with camlocks (3) and screw (13).

# 3

9



1 PC

12



14 PCS  $\phi 3 \times 12$  D=7

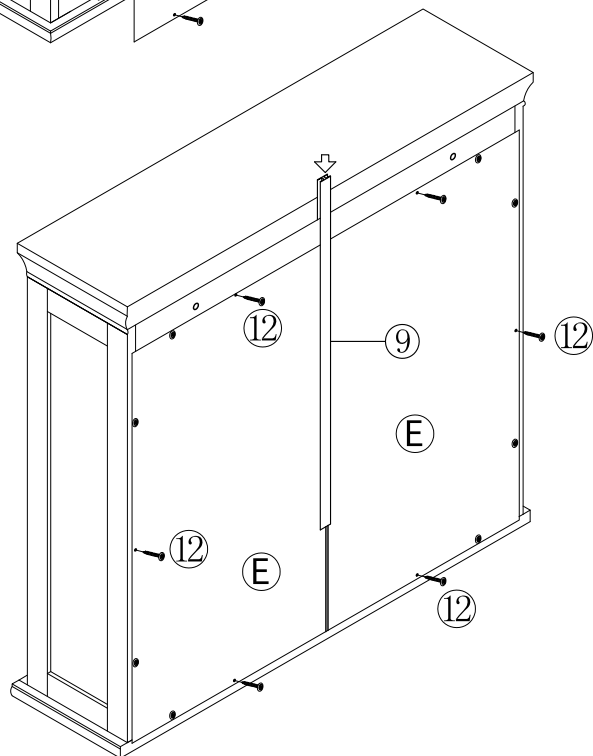
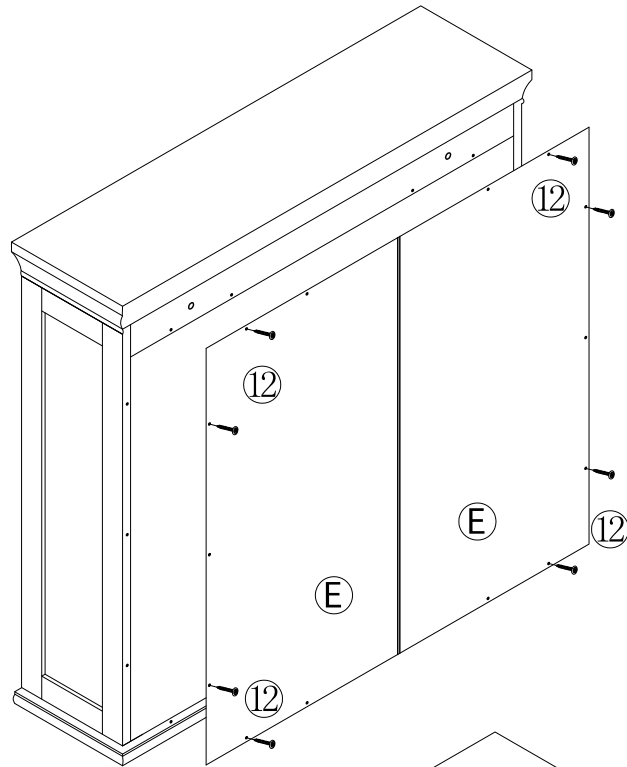

## STEP 3:

1. Attach panels E to the back of the cabinet & secure the four corners with screws (12).
2. Insert plastic bar between the two panel Es and finish securing the panels with screw (12).

# 4

5

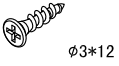

8 PCS

6



2 PCS

7



2 PCS

8



4 PCS

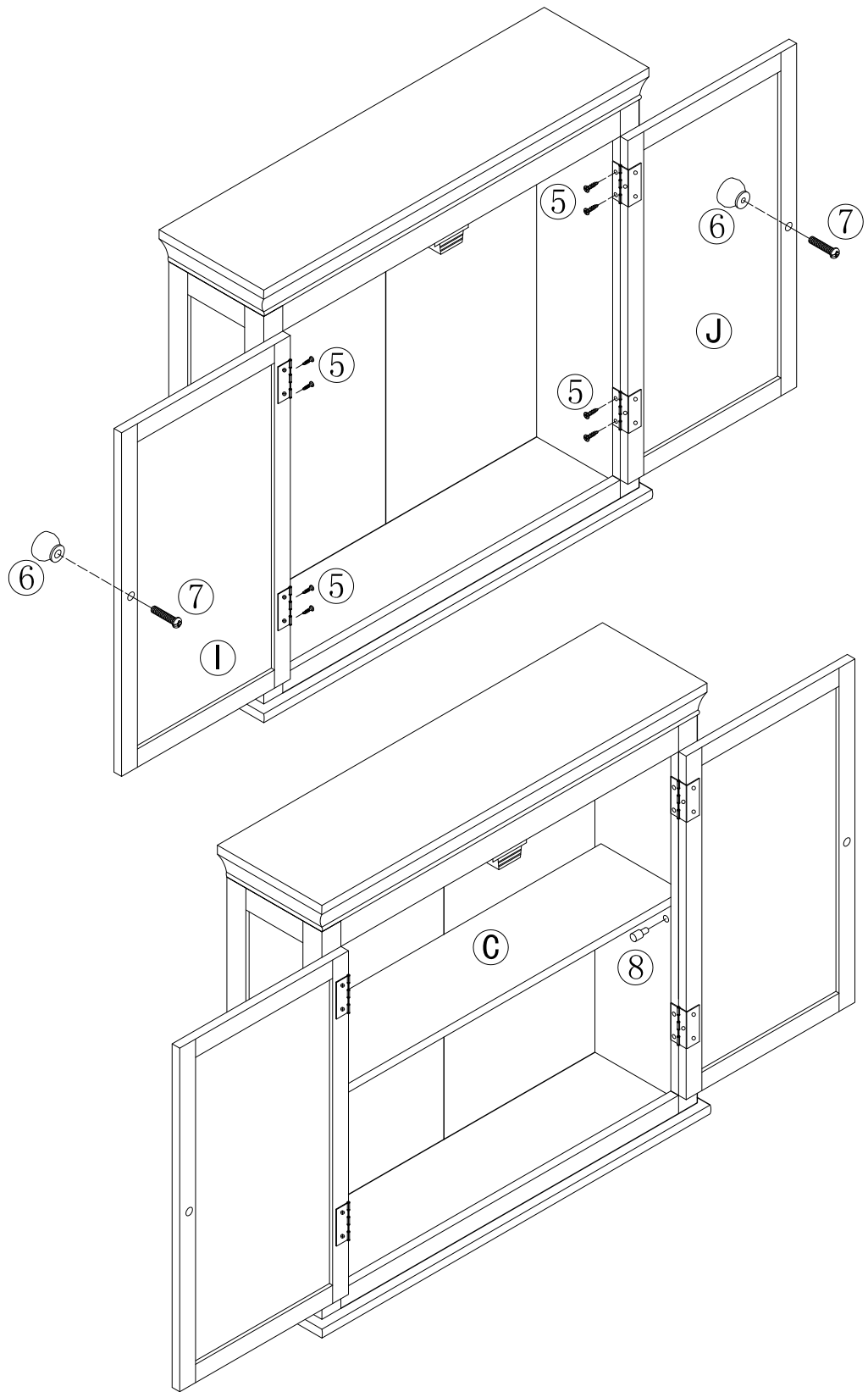

## STEP 4:

1. Attach knobs (6) to doors I & J with bolts (7).
2. Attach doors I & J with screws (5).
3. Insert shelf pins (8) in panels A & B and rest the adjustable shelf on the shelf pins.



# 5

10



2 PCS

11



2 PCS  $\phi 4 \times 35$

