

Assembly Instructions

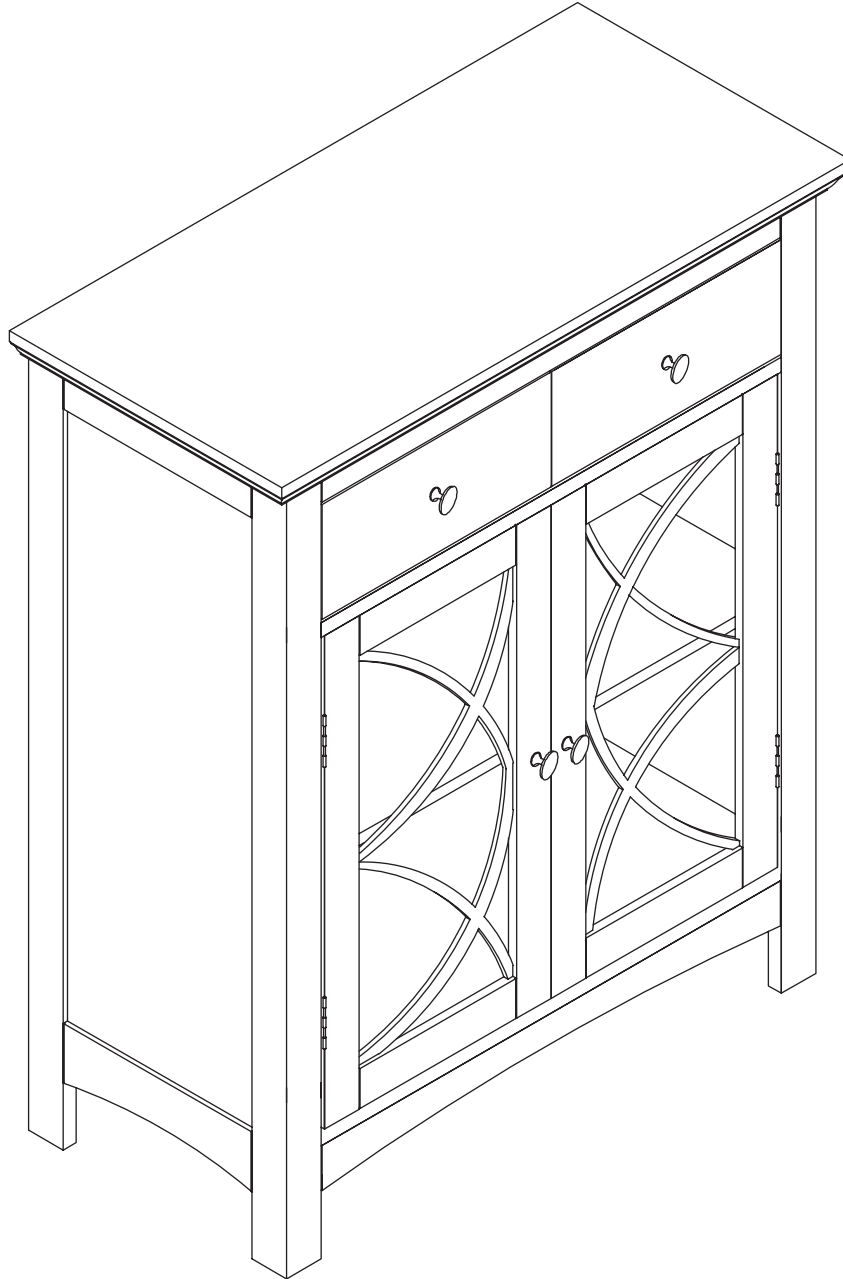

Carefully unpack and identify each component before beginning assembly. Before you begin, please refer to parts list to make sure that you have all parts. Please take care when assembling the unit and always place the parts on a clean, soft surface. If you require assistance with assembly or parts, please call us.

Parts List

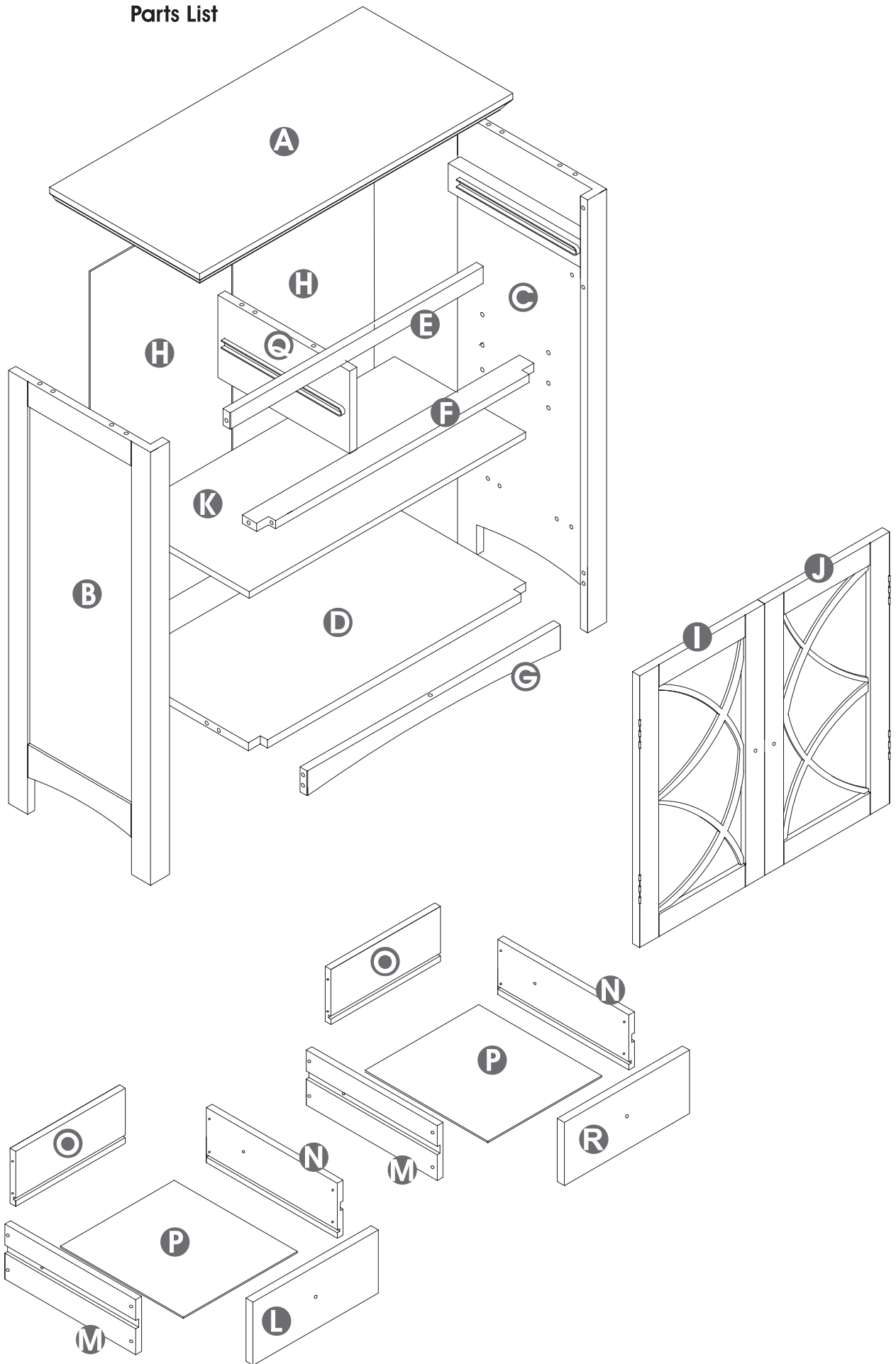
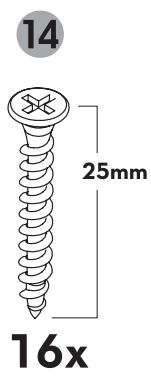
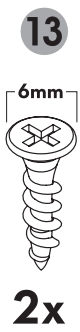
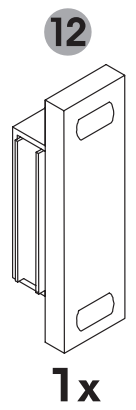
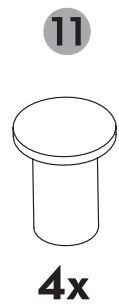
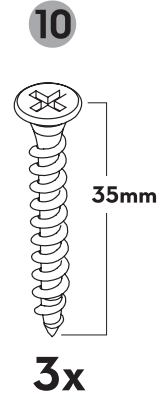
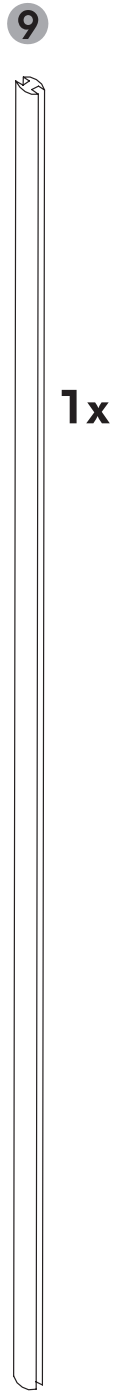
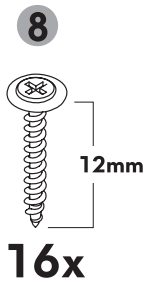
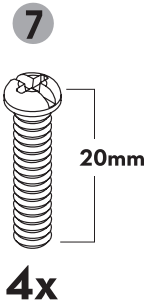
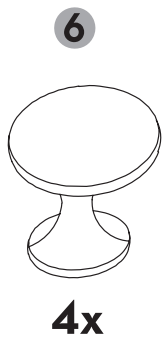
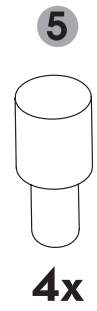
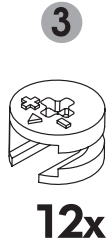



in **Step 1** you need **B C D E F G**

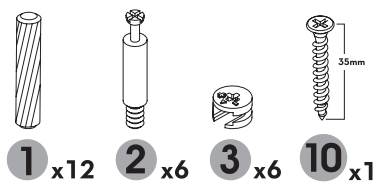

First screw cam bolt **2** into part B, C,
then slide part D, F into part B, C,
lastly tighten the cam lock **3** until secure.

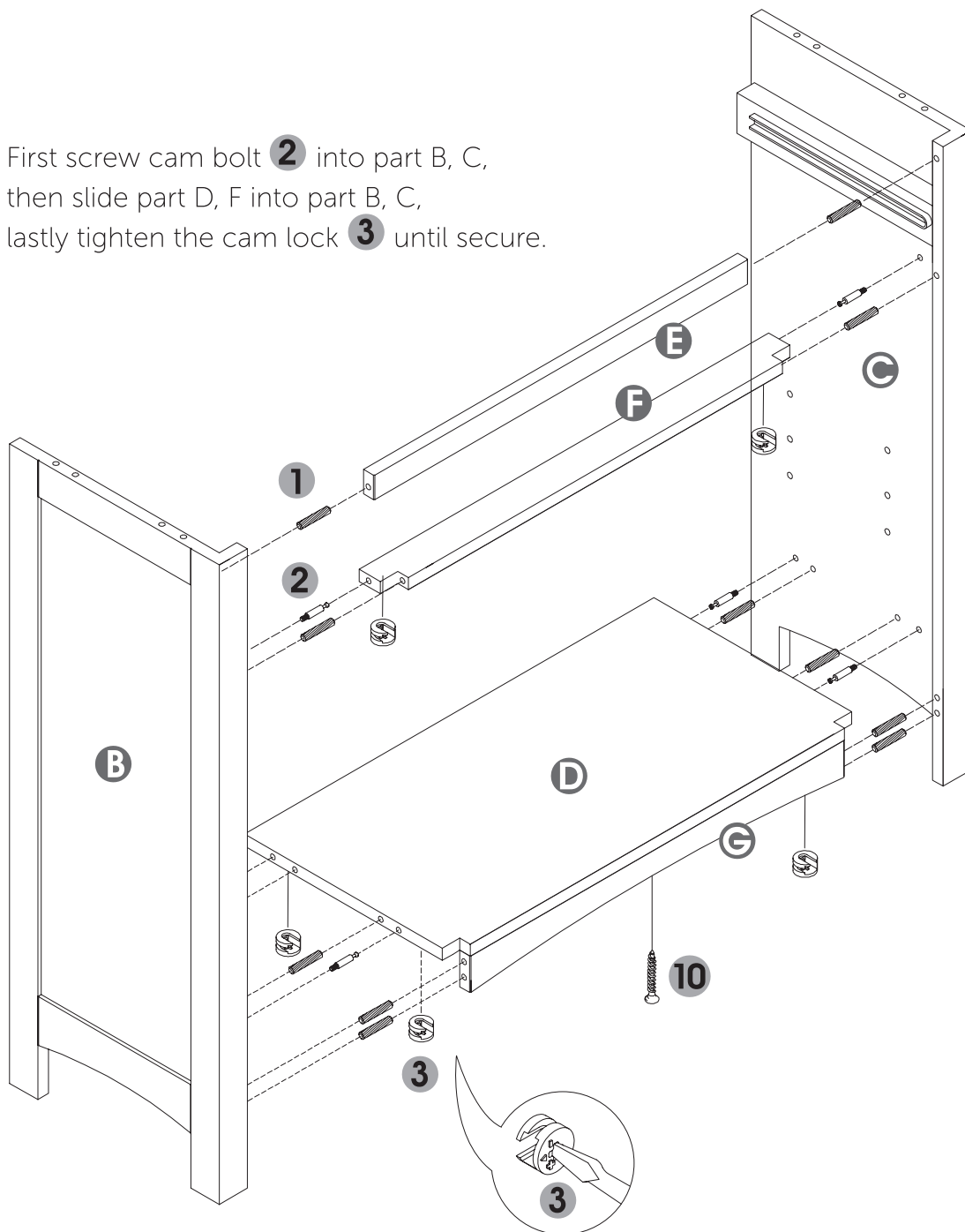

Push cam lock into the hole, then
take a flathead screwdriver (as
pictured) and twist 45 degrees until
it is locked in place.

in **Step 2** you need

A **Q**

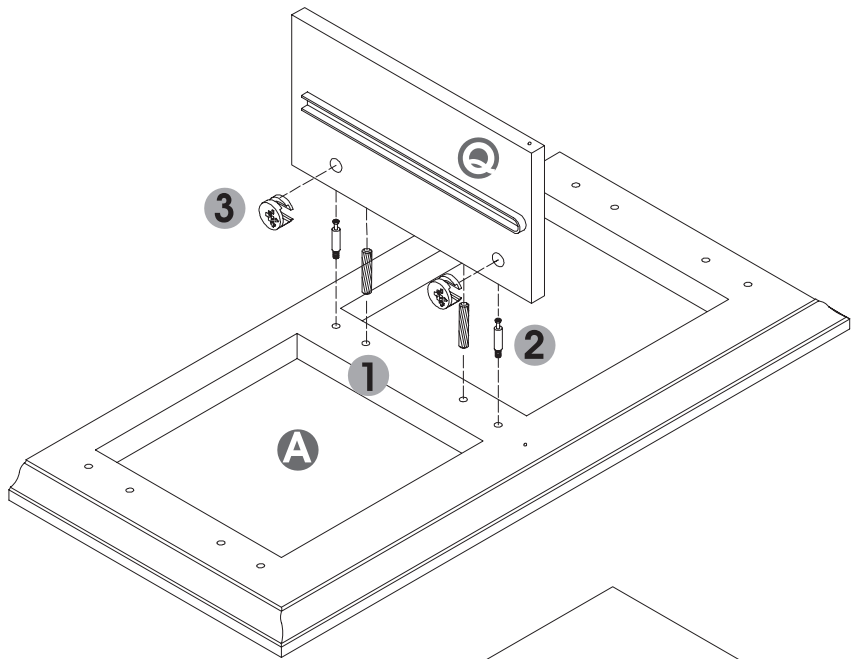
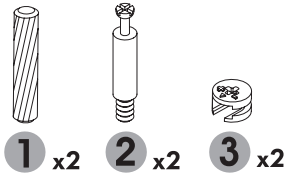

in **Step 3** you need

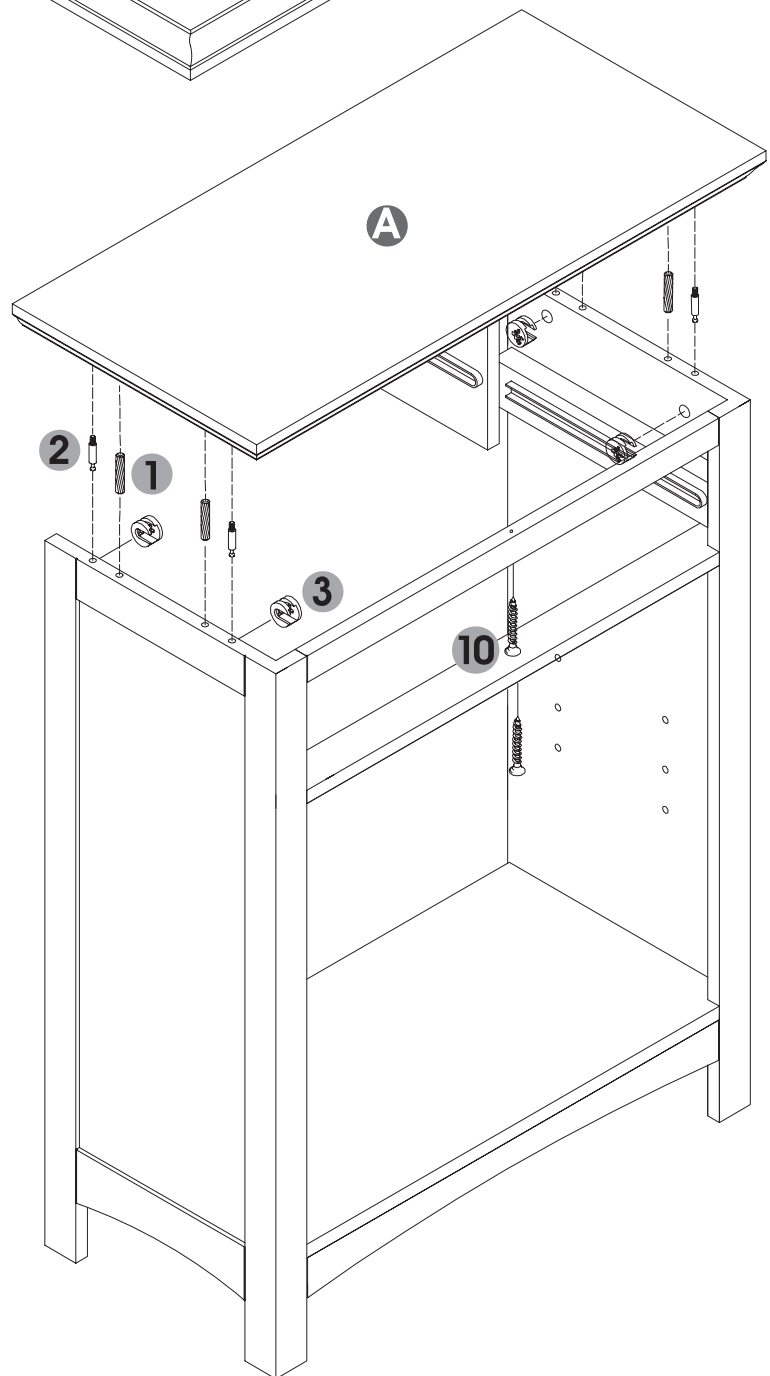
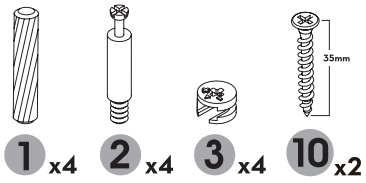

in **Step 4** you need

H

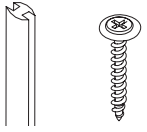

9 x1 **8** x16

back connector slide

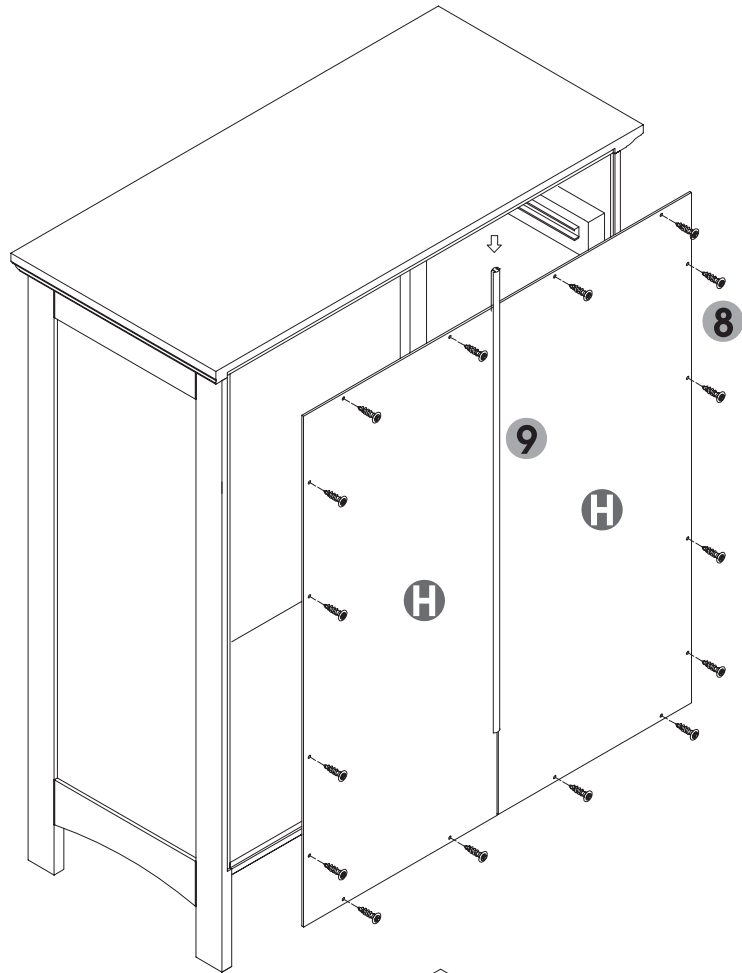

in **Step 5** you need

I **J**

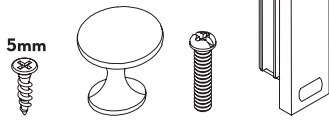

4 x8 **6** x2 **7** x2 **12** x1 **13** x2

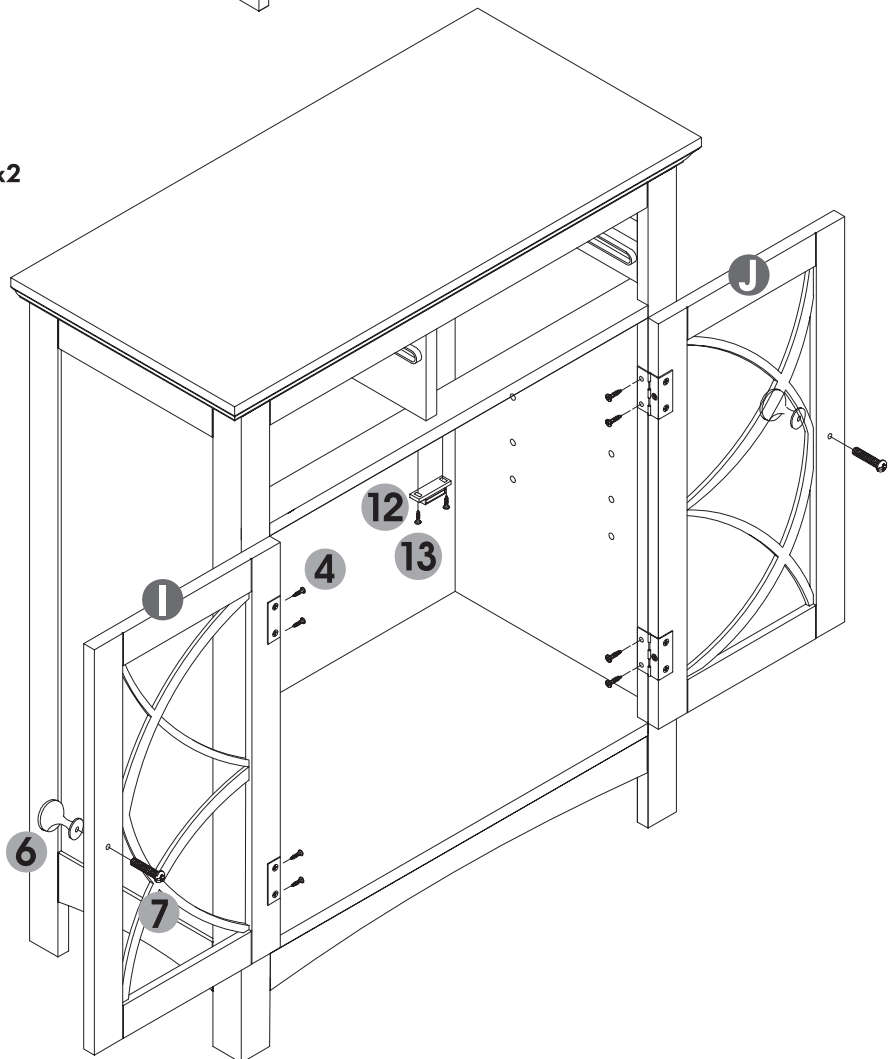

in **Step 6** you need

K



5 x4

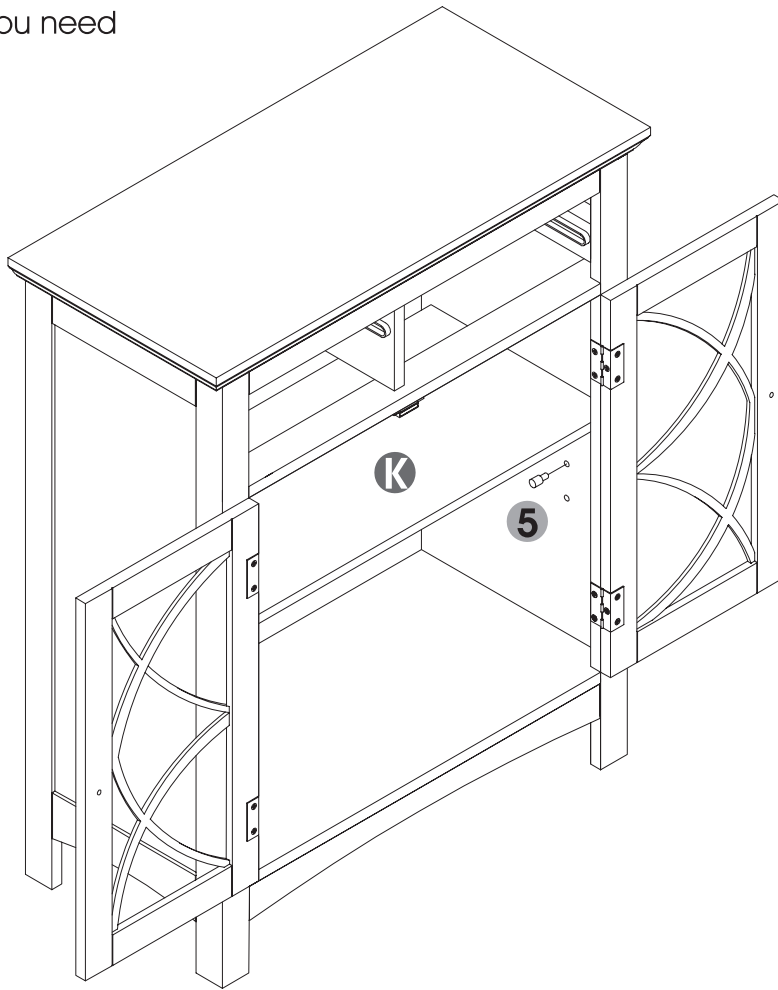

in **Step 7** you need

O M P L N R



6 x2



7 x2

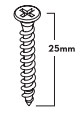

14 x16

Please make sure that the drawer stopper holes are closest to the back.

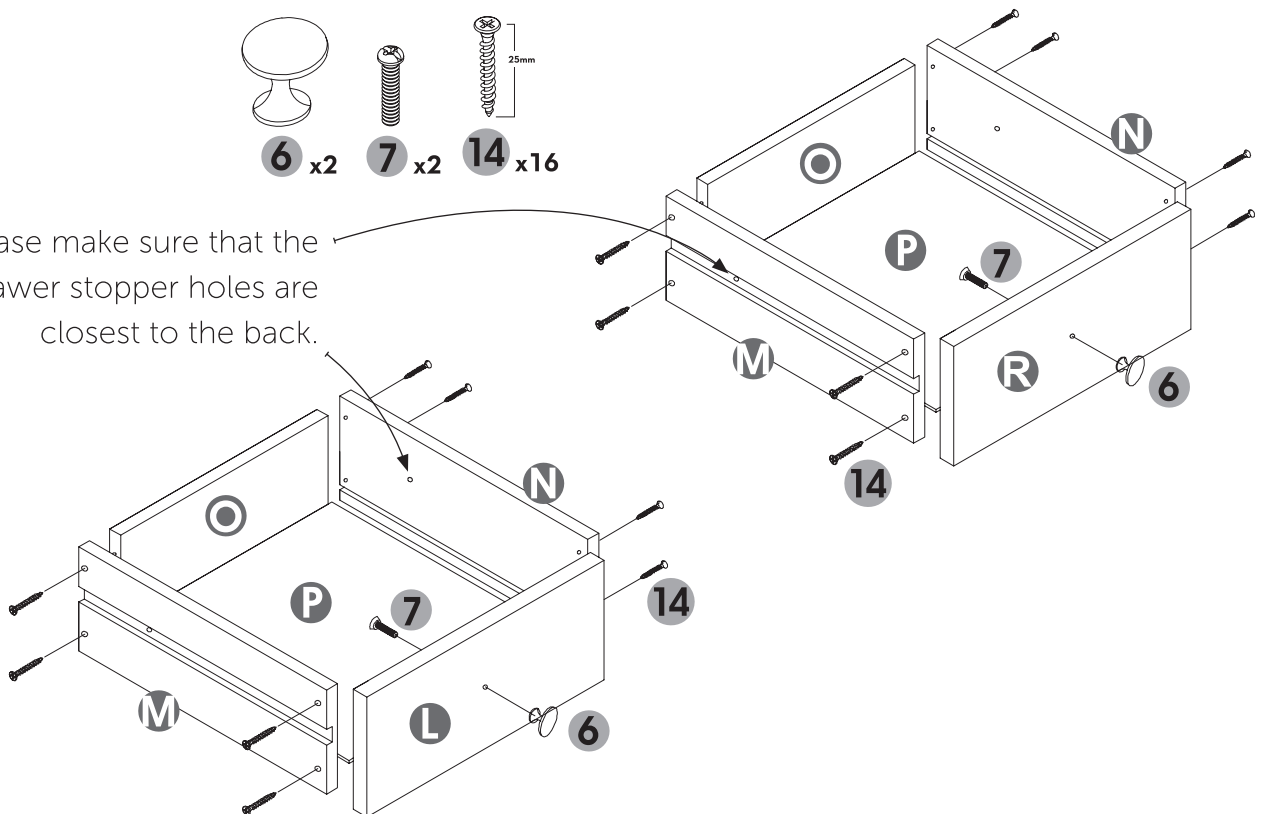

in **Step 8** you need



11_{x4}

Slide the drawer in partially
then insert the drawer
stoppers **11**.

