



ASSEMBLY INSTRUCTIONS & PARTS IDENTIFICATION CHAIRSIDE TABLE

Thank you for purchasing this quality product. Be sure to check all packing material carefully for small parts that may have come loose inside the carton during shipment .

Table Components				Hardware Kit			
No.		Description	Q'TY	No		Description	Q'TY
1		Table Top	1 PC	A		Lock Washer	4 PCS
2		Middle Shelf	1 PC	B		Flat Washer	12 PCS
3		Bottom Shelf	1 PC	C		Wing Nut	4 PCS
4		Upper Leg	4 PCS				
5		Lower Leg	4 PCS				
6		Floor Glides	4 PCS				

Step 1 Lay the tabletop upside down on a clean padded surface to prevent scratches. Attach the metal legs by screwing them into the inserts on the tabletop.

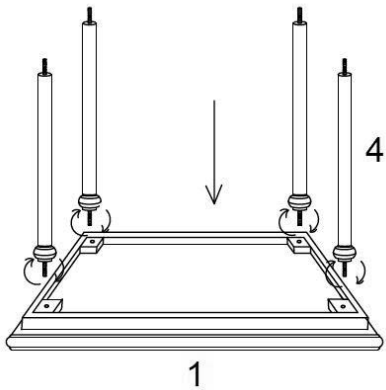

Step 2 Place a flat washer over the threads of the metal legs. Lay the middle shelf on the upper legs and align the holes with the threads in the legs. Place a flat washer over the threads of the metal legs on top of the shelf. Attach the lower metal legs by screwing into the inserts on the upper legs.

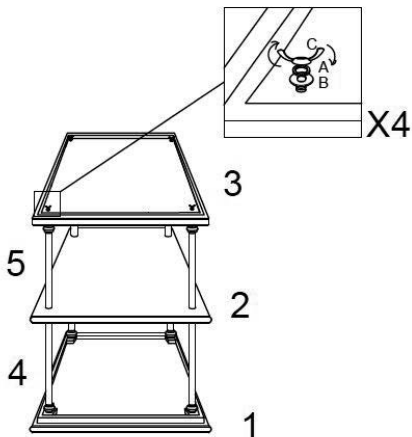
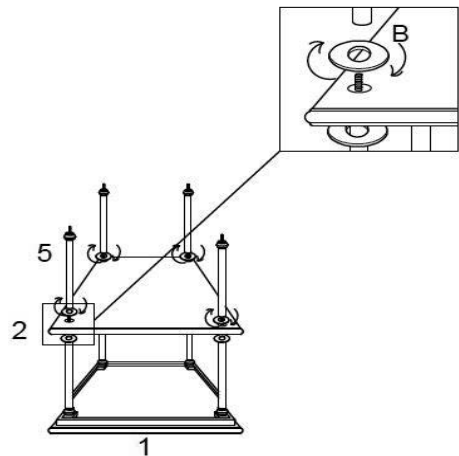

Step 3 Lay the bottom shelf on the lower legs and align the holes with the threads in the legs. Attach using a flat washer, lock washer and wing nut. Once all wing nuts are in place tighten all the wing nuts securely.

