

Metal Garden Shed

10x8FT

Assembly Instruction

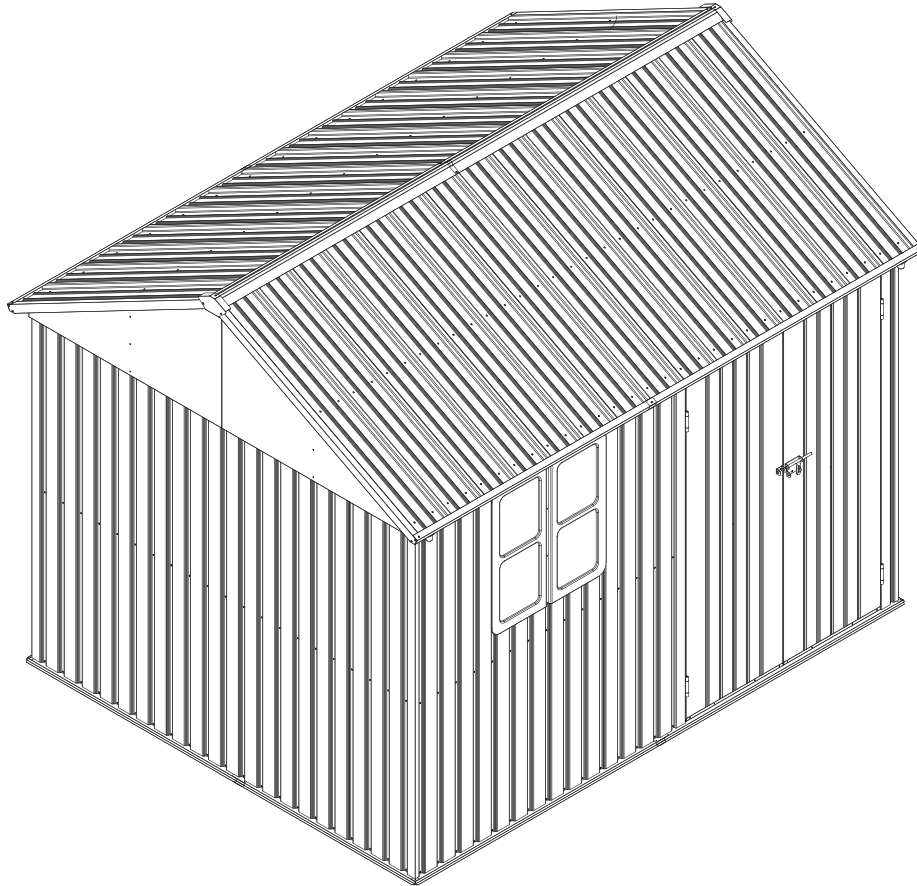

ASSEMBLY INSTRUCTIONS







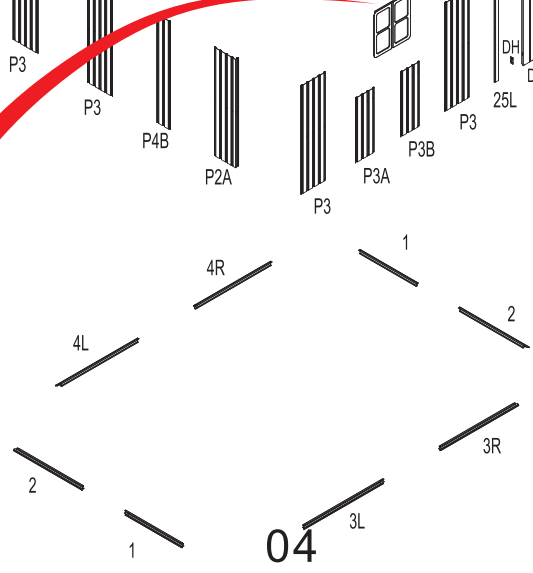
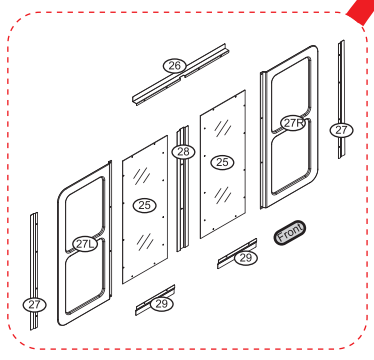
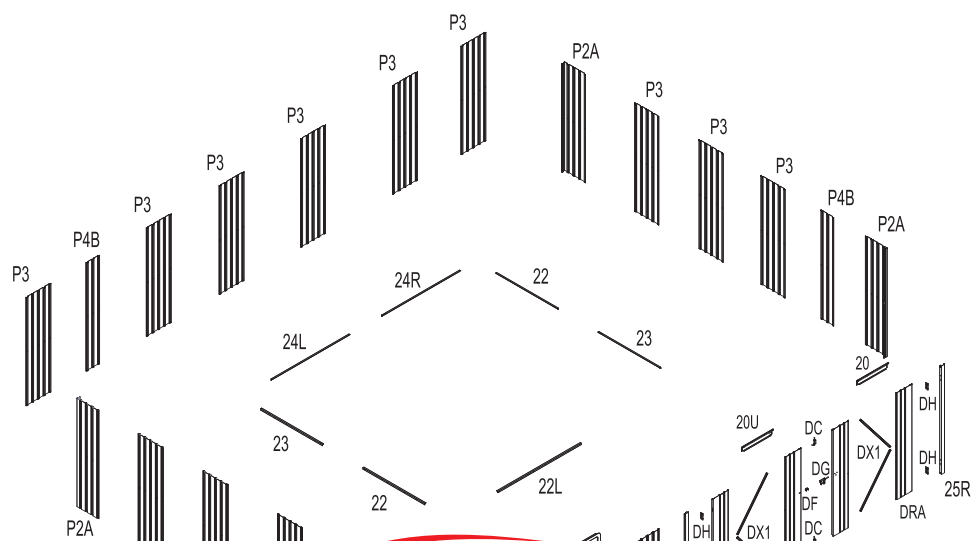
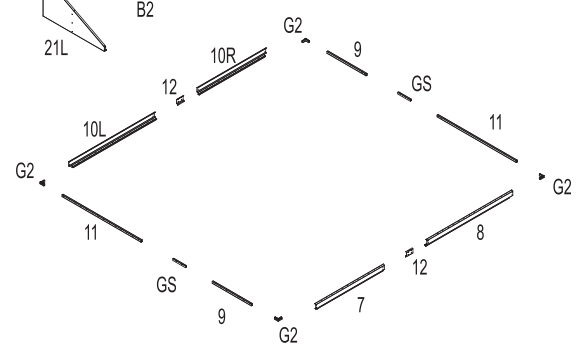
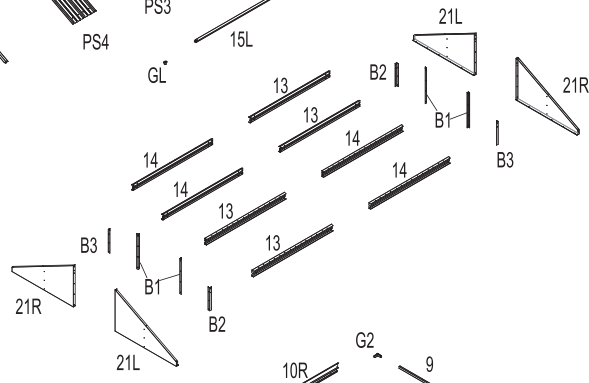
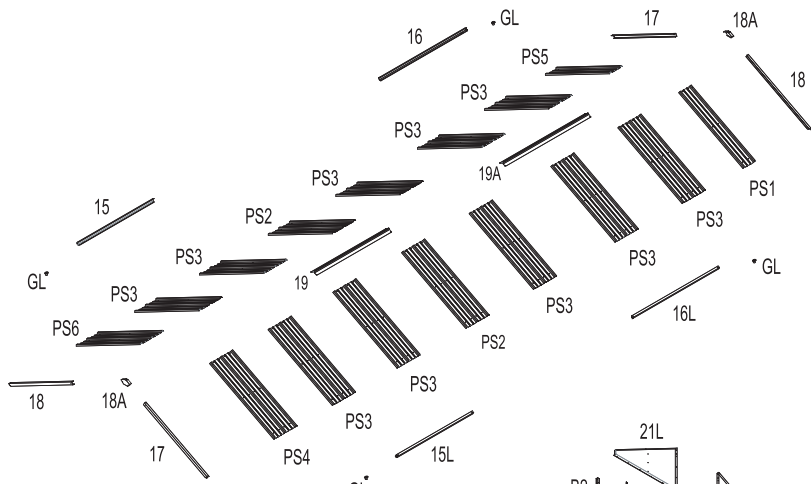

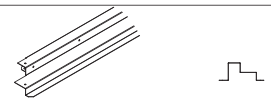

WARNING







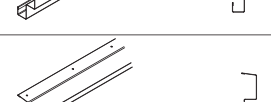
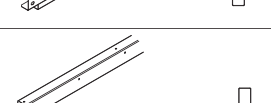
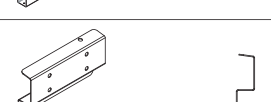
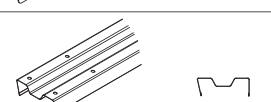
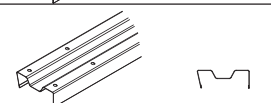
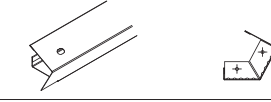

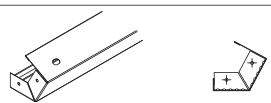

Please read the instruction manual carefully before assembly.
Please assembly strictly in accordance with the instruction.
Please double-check to ensure that all parts of the package contents intact.
To avoid injury, work gloves are recommended during assembly.







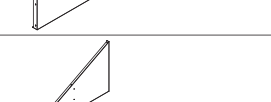
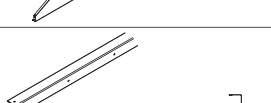
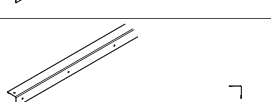
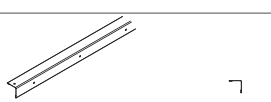
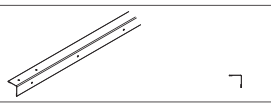
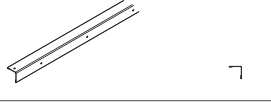
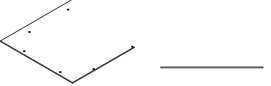





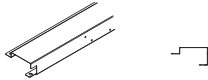

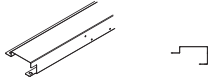

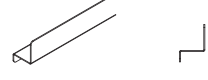



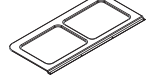
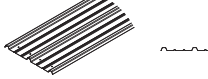

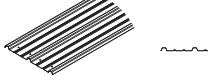





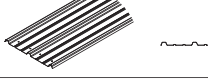
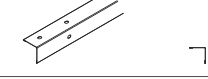



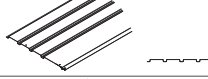

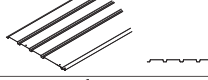

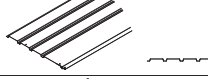







PARTS LIST

NO.	PART	Qty.
1		2
2		2
3L		1
3R		1
4L		1
4R		1
7		1
8		1
9		2
10L		1
10R		1
11		2
12		2
13		4
14		4
15		1
15L		1

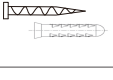
NO.	PART	Qty.
16		1
16L		1
17		2
18		2
19		1
19A		1
20		2
20D		1
20U		1
21L		2
21R		2
22		2
22L		1
23		2
24L		1
24R		1
25		2

PARTS LIST

NO.	PART	Qty.	NO.	PART	Qty.
25L		1	P3A		1
25R		1	P3B		1
26		1	P4B		3
27		2	PS1		1
27L		1	PS2		2
27R		1	PS3		10
28		1	PS4		1
29		2	PS5		1
B1		4	PS6		1
B2		2	DC		2
B3		2	DF		1
DLA		1	DG		1
DLB		1	DH		4
DRA		1	DX1		4
DRB		1	G2		4
P2A		4	GL		4
P3		14	GS		2
18A		2	F1		596
F4		5	F2		54
F6		4	F3		32
			S1		352
			S2		580

NO.	PART	Qty.
F1		16

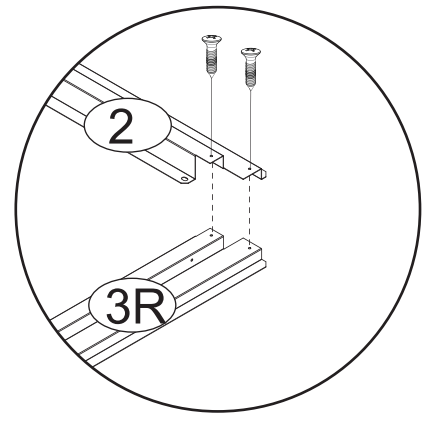
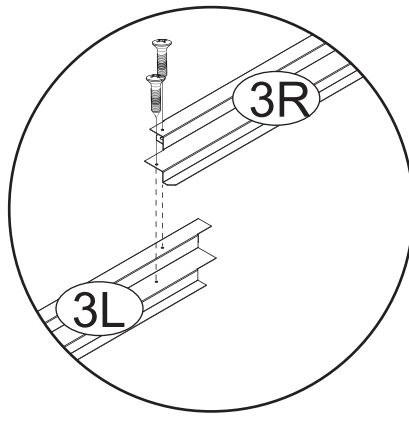
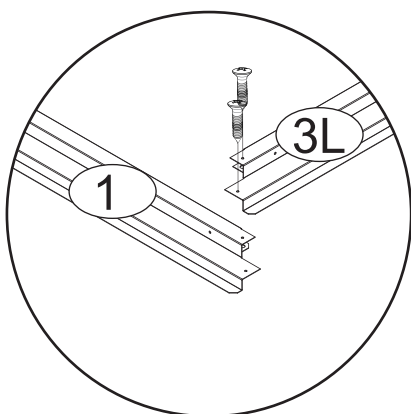
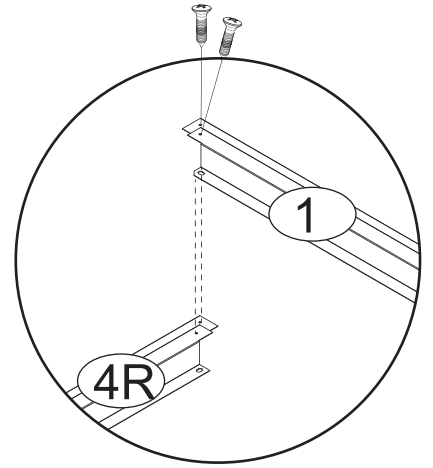
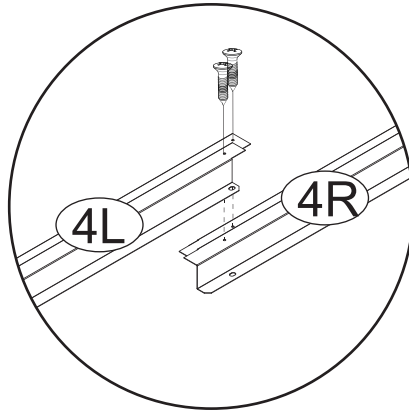
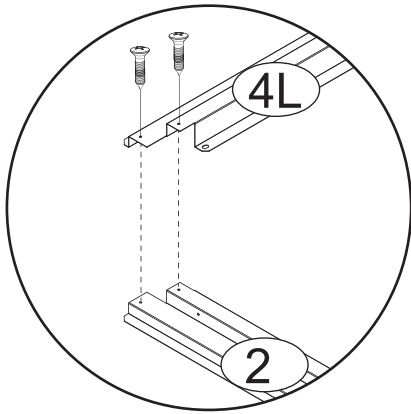
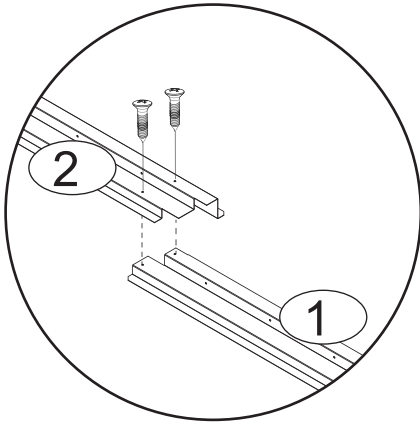
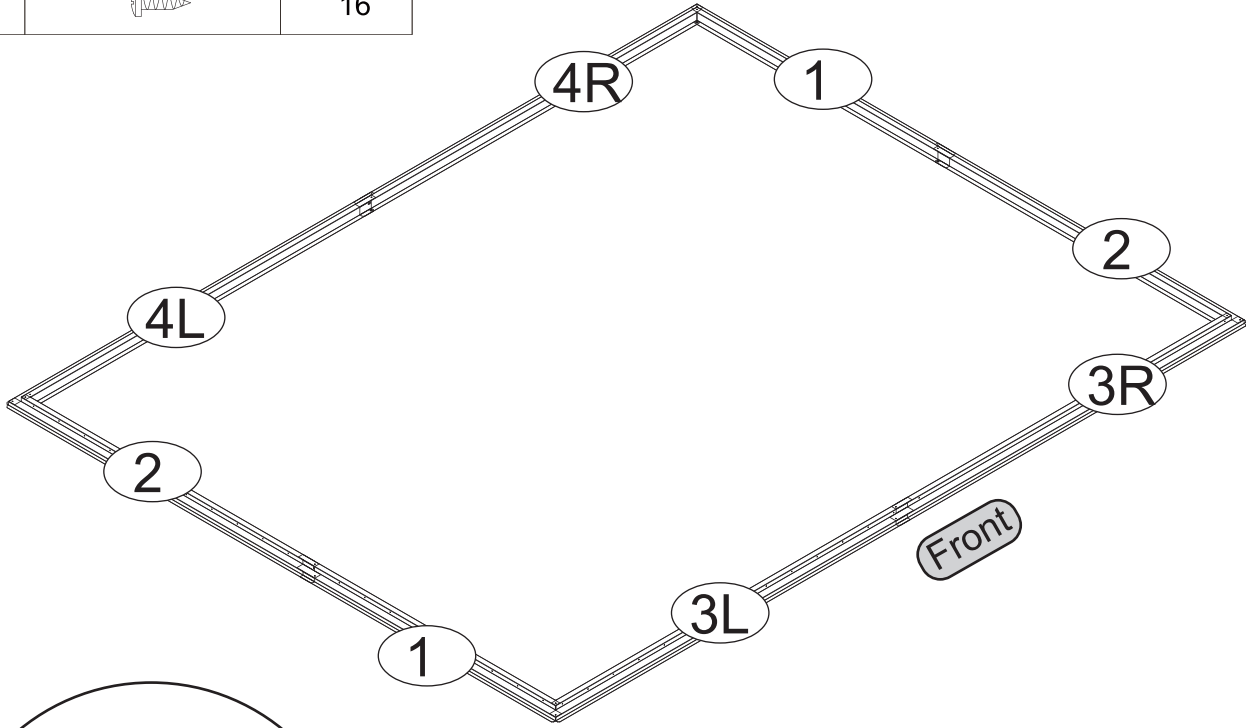

NO.	PART	Qty.
P2A		4
F1		12
S2		12

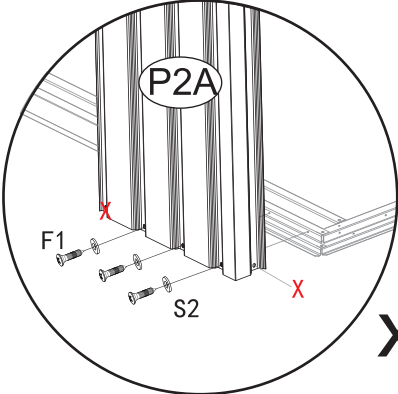

x4

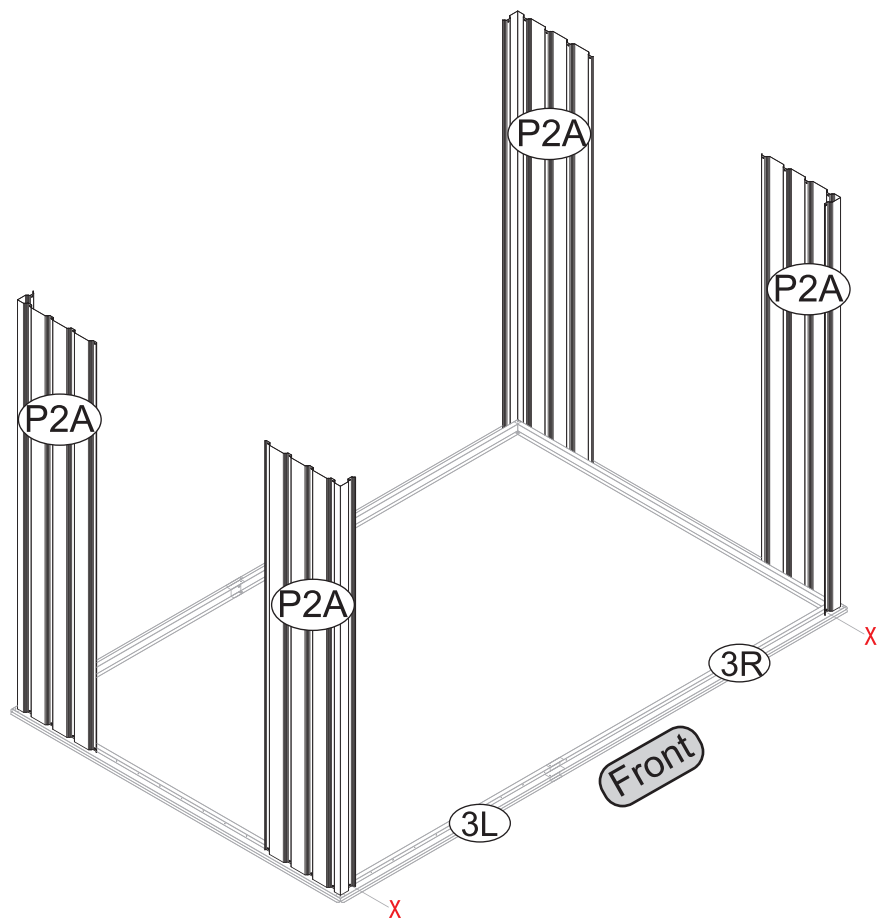



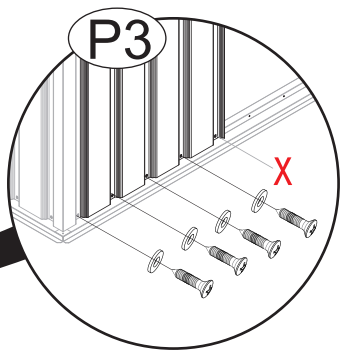
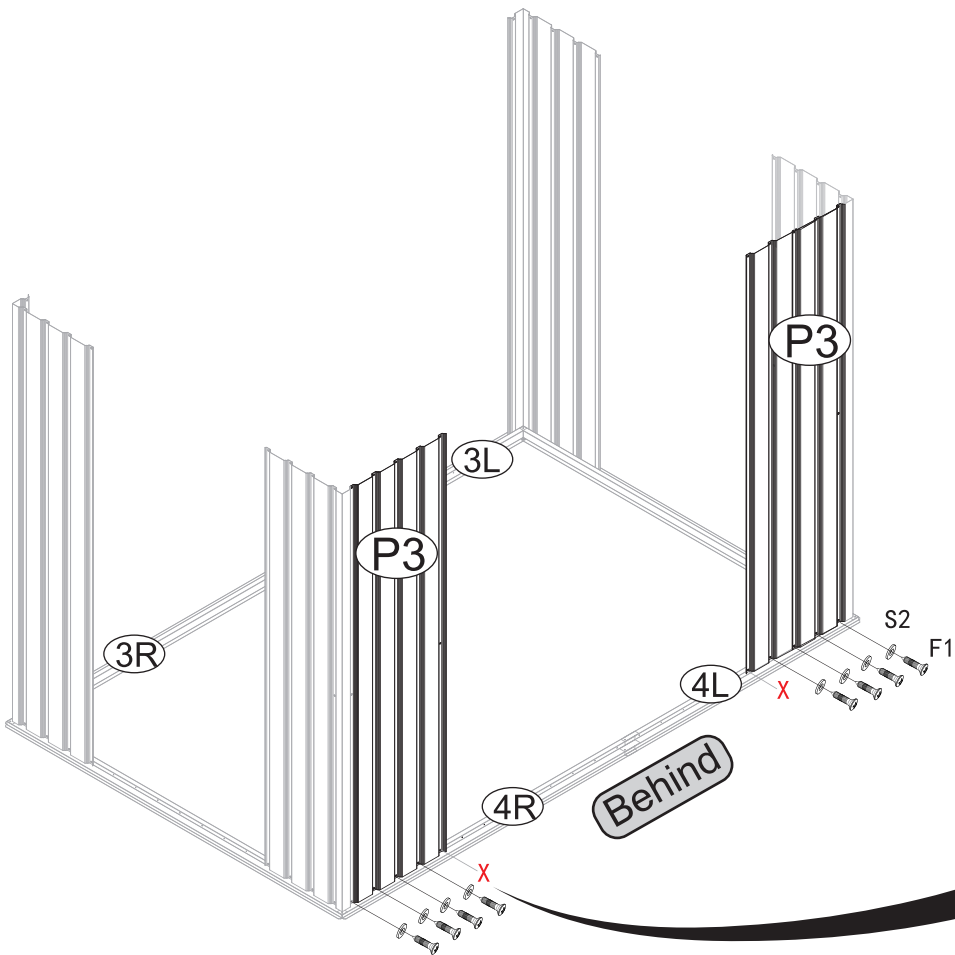

NO.	PART	Qty.
P3		2
F1		8
S2		8





this side is the back, please assemble on the 4L,4R

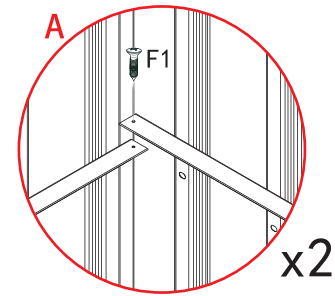
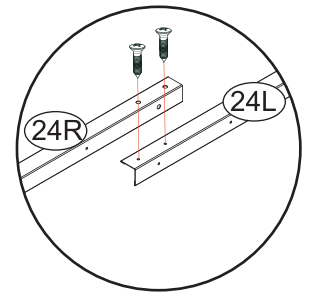
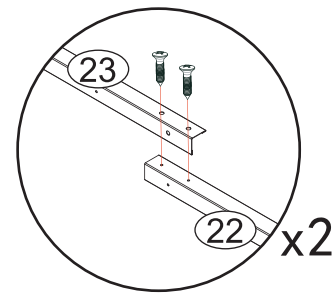
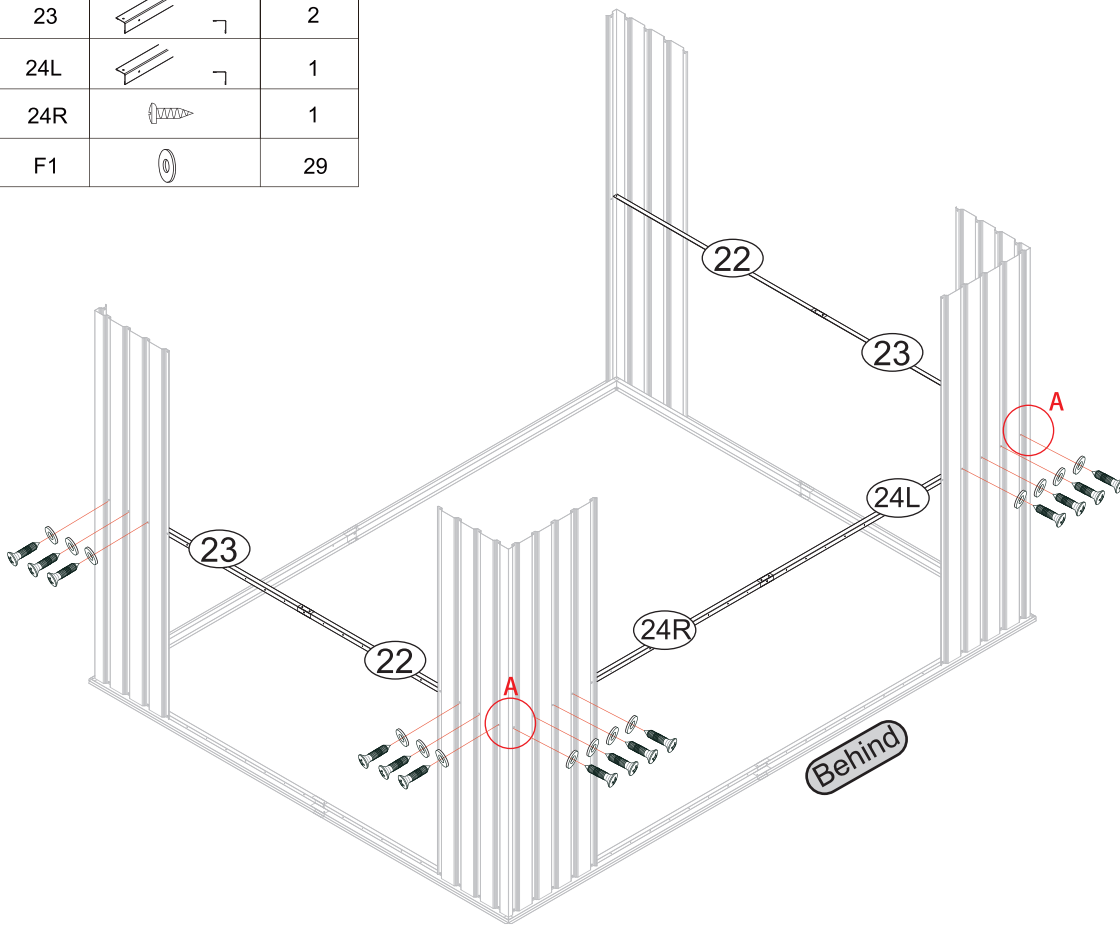

x2

NO.	PART	Qty.
22		2
23		2
24L		1
24R		1
F1		29



NO.	PART	Qty.
F1		98
S2		98
P3		10
P4B		2

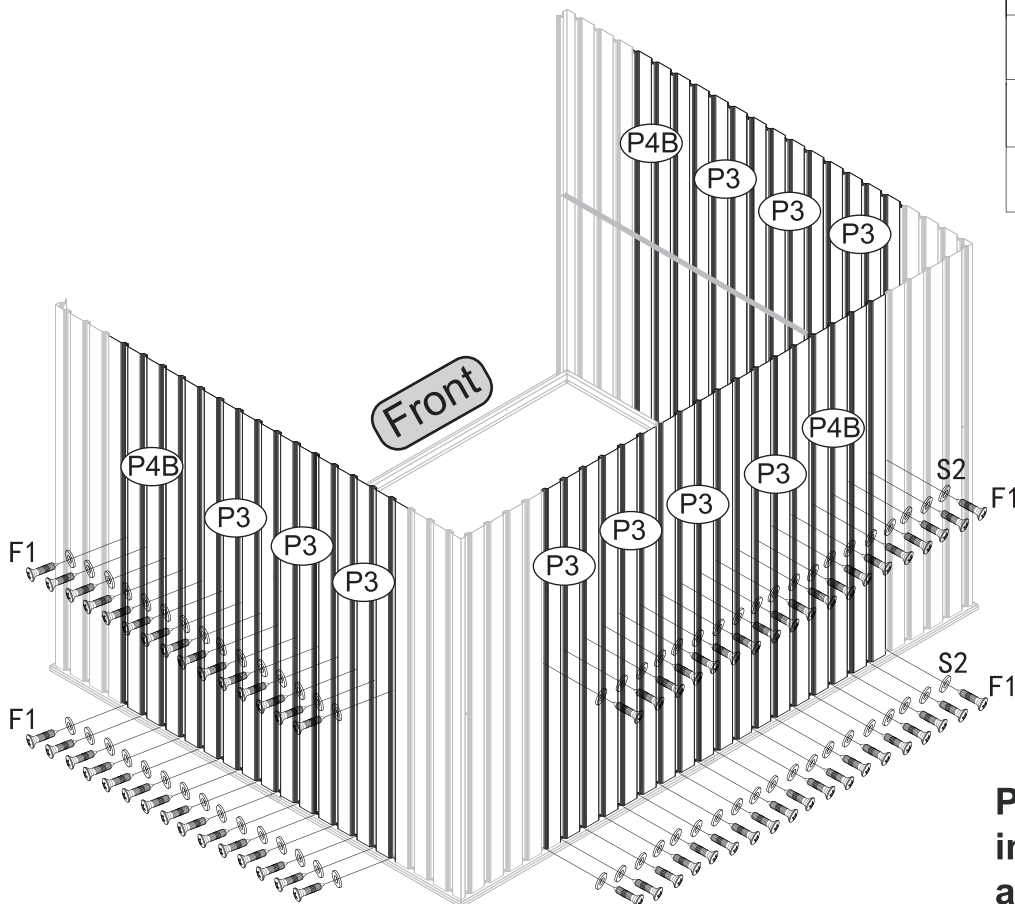

Pay attention to tipping, and install the screw holes after alignment.

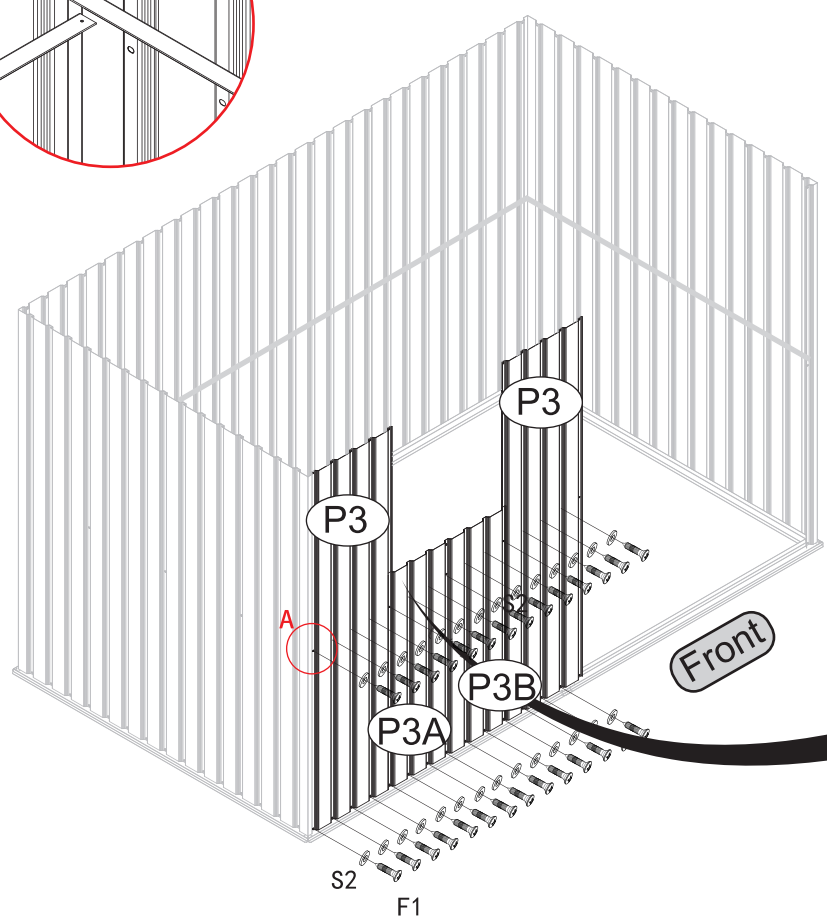
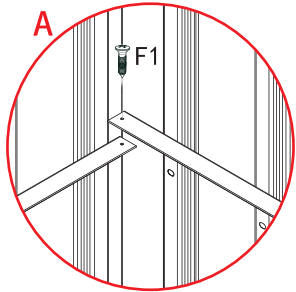

NO.	PART	Qty.
P3		2
P3A		1
P3B		1
F1		28
22L		1
S2		28

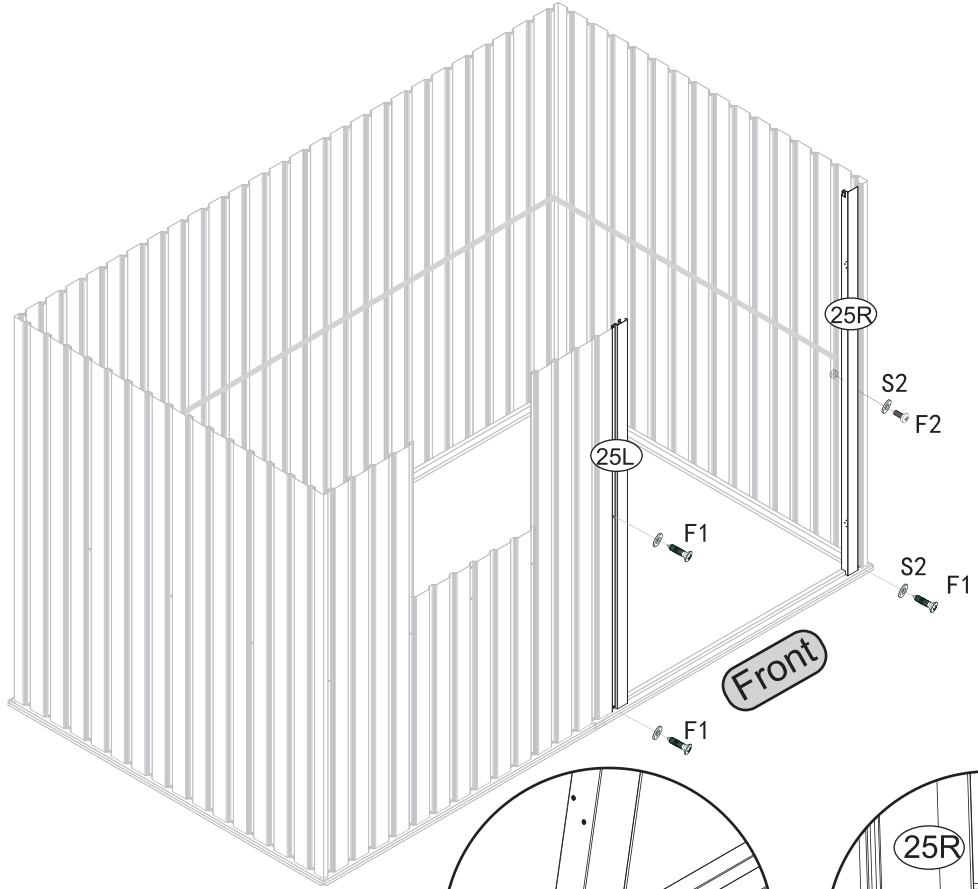
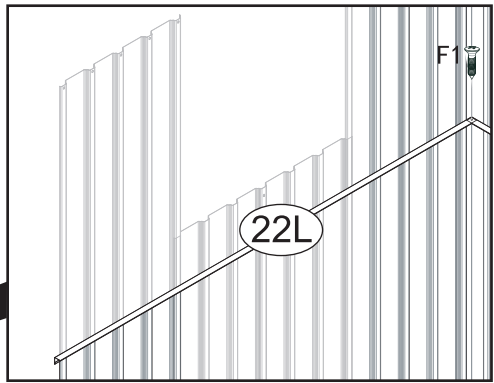

NO.	PART	Qty.
25L		1
25R		1
F1		5
F2		1
S2		4

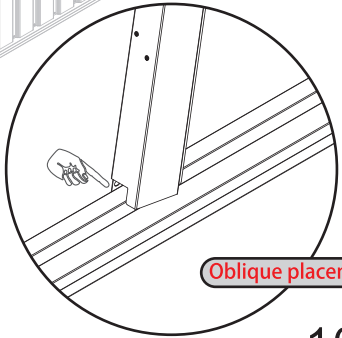

Oblique placement

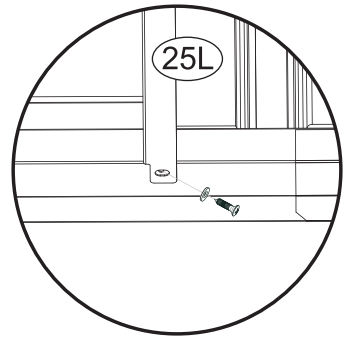
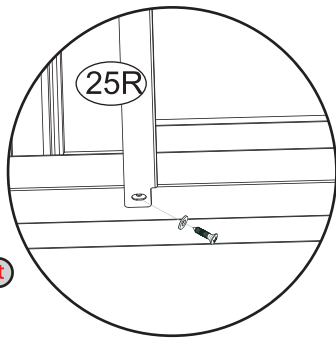

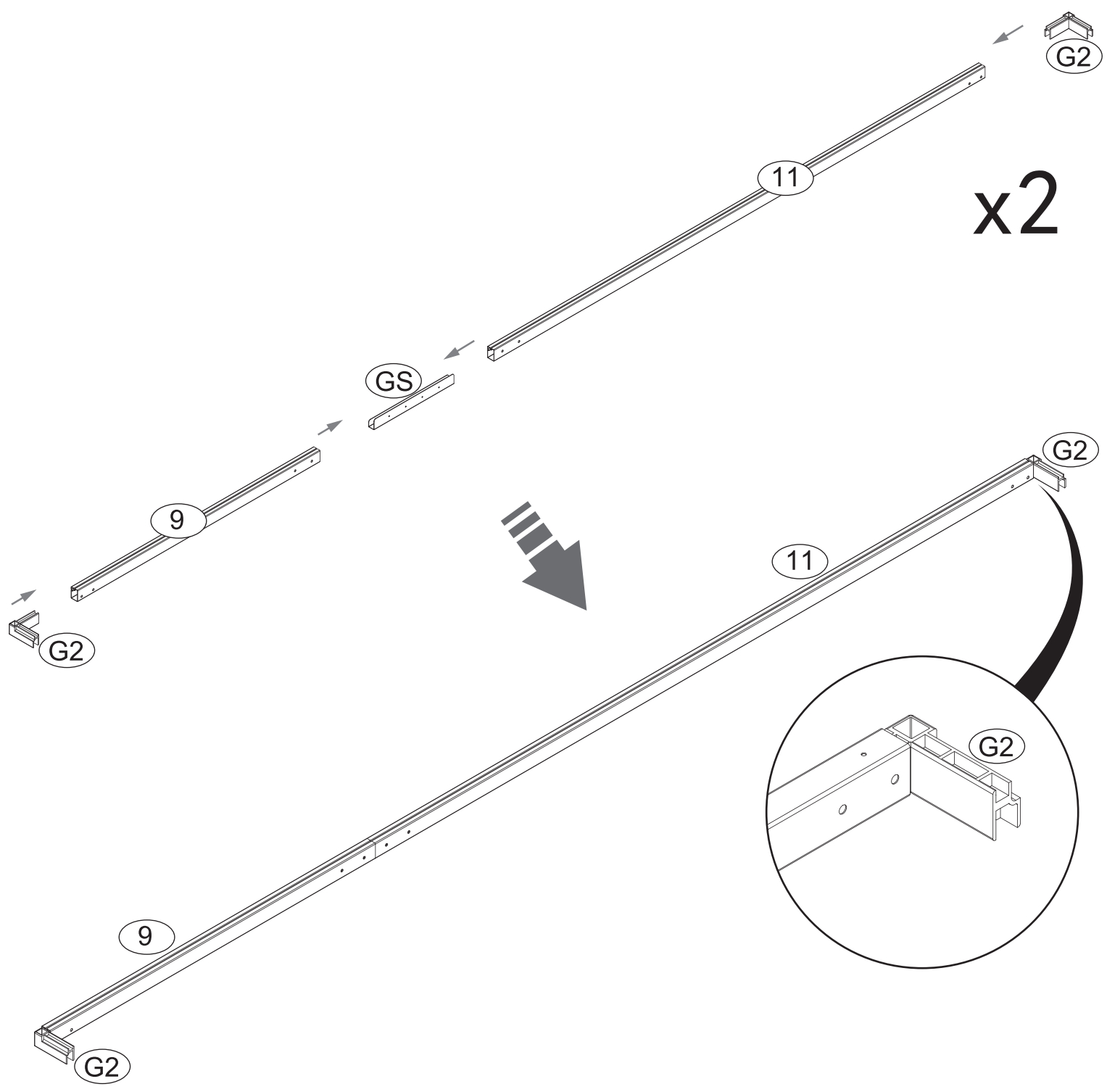

The installation details of 9 and 11 are on the next page

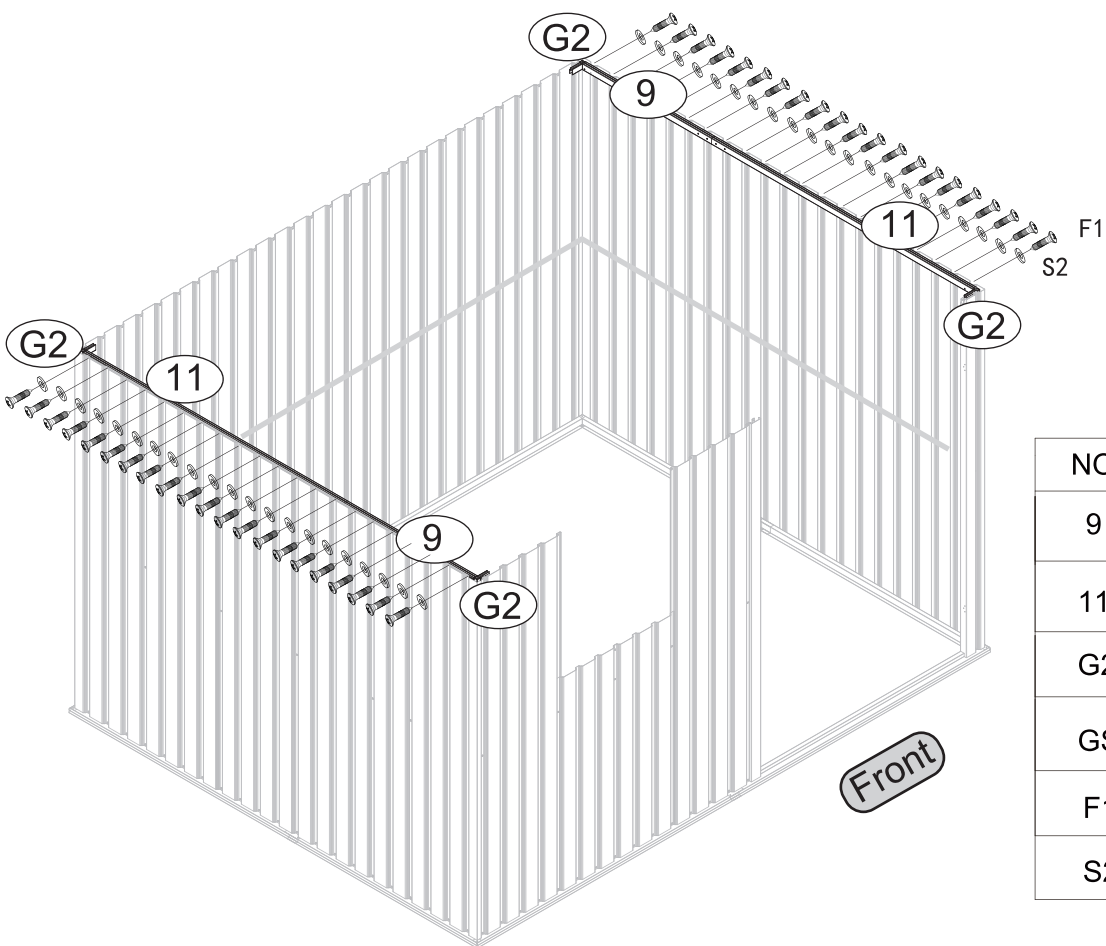

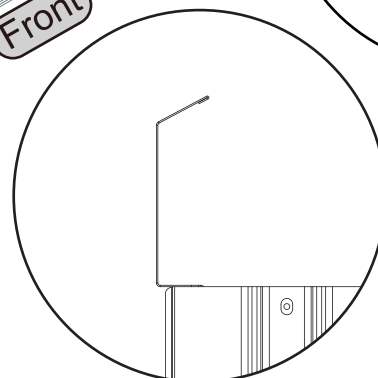
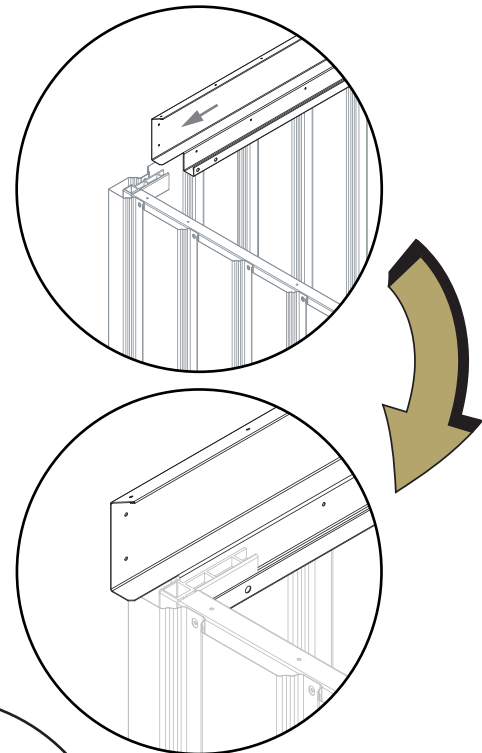
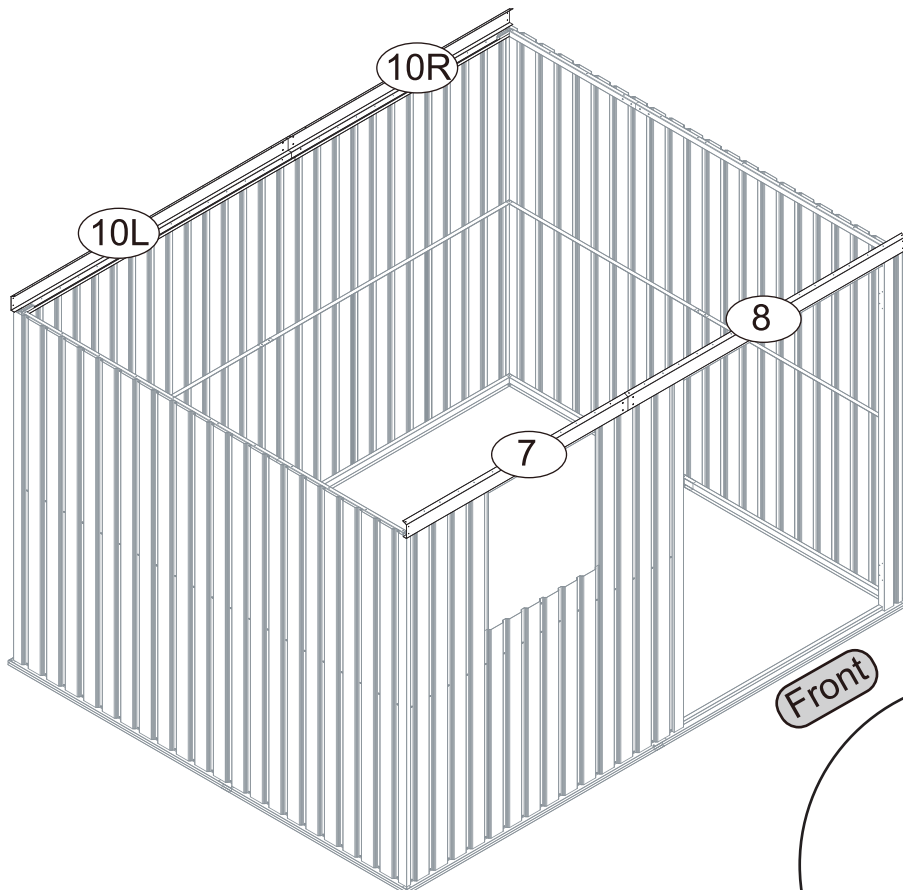

NO.	PART	Qty.
9		2
11		2
G2		4
GS		2
F1		42
S2		42

Insert four different products into G2 separately

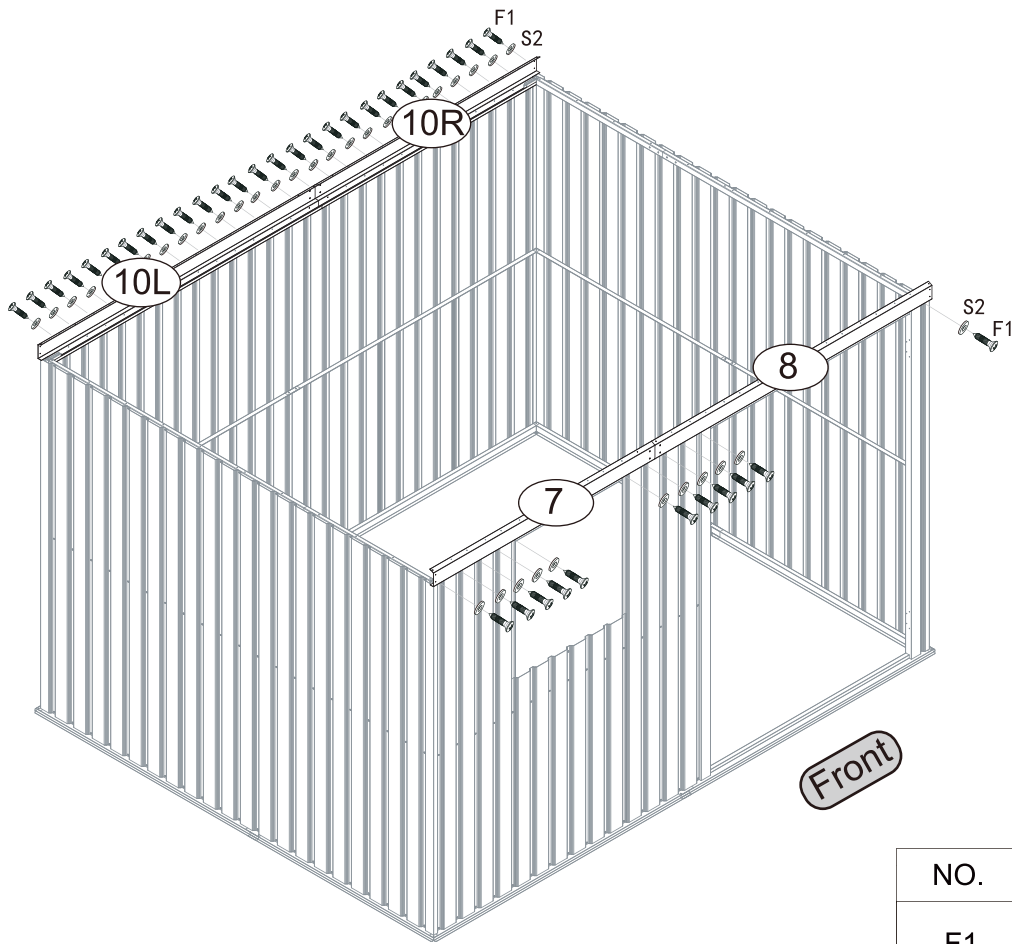





NO.	PART	Qty.
F1		38
S2		38

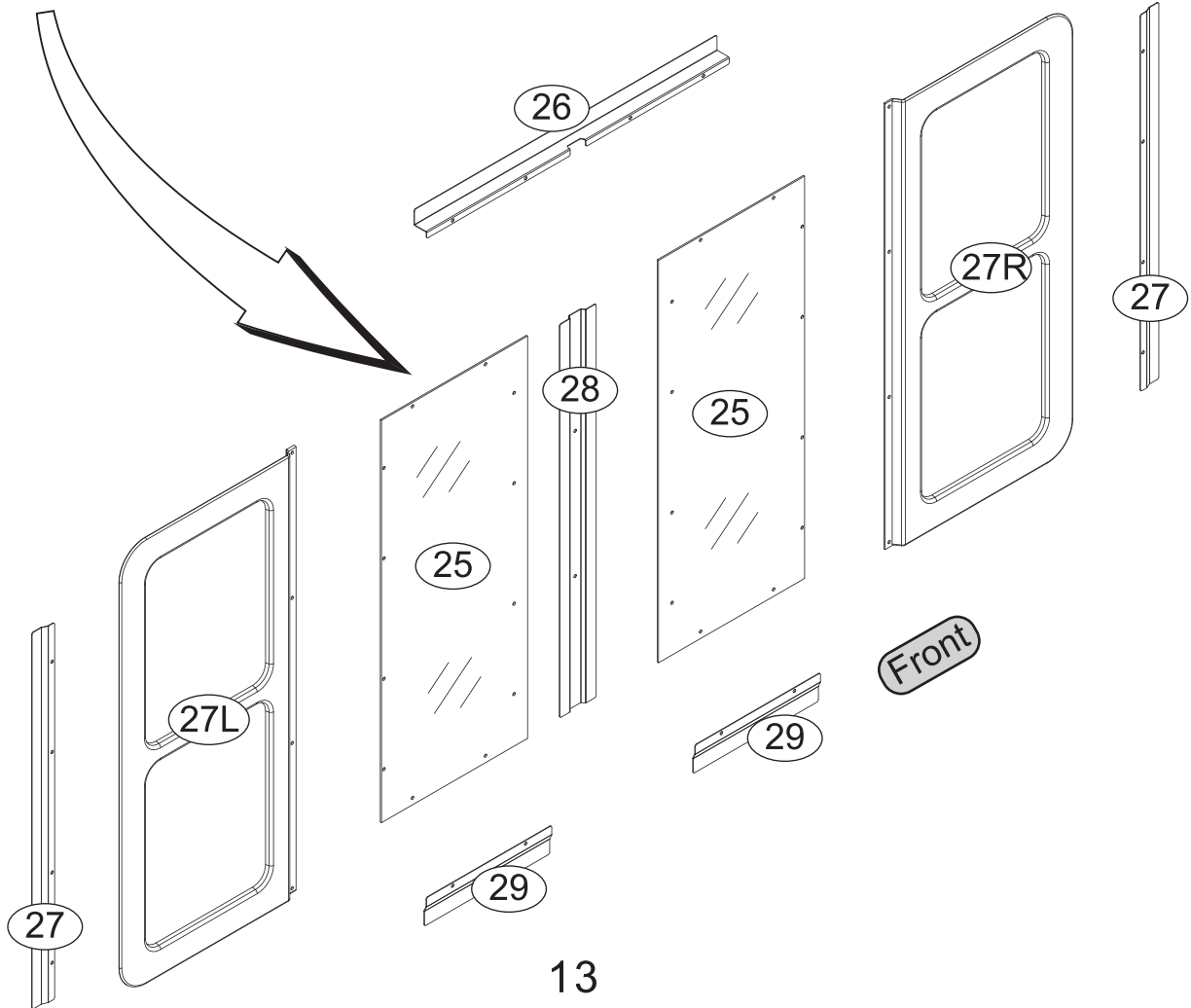

Before installing the window, peel off the film covering

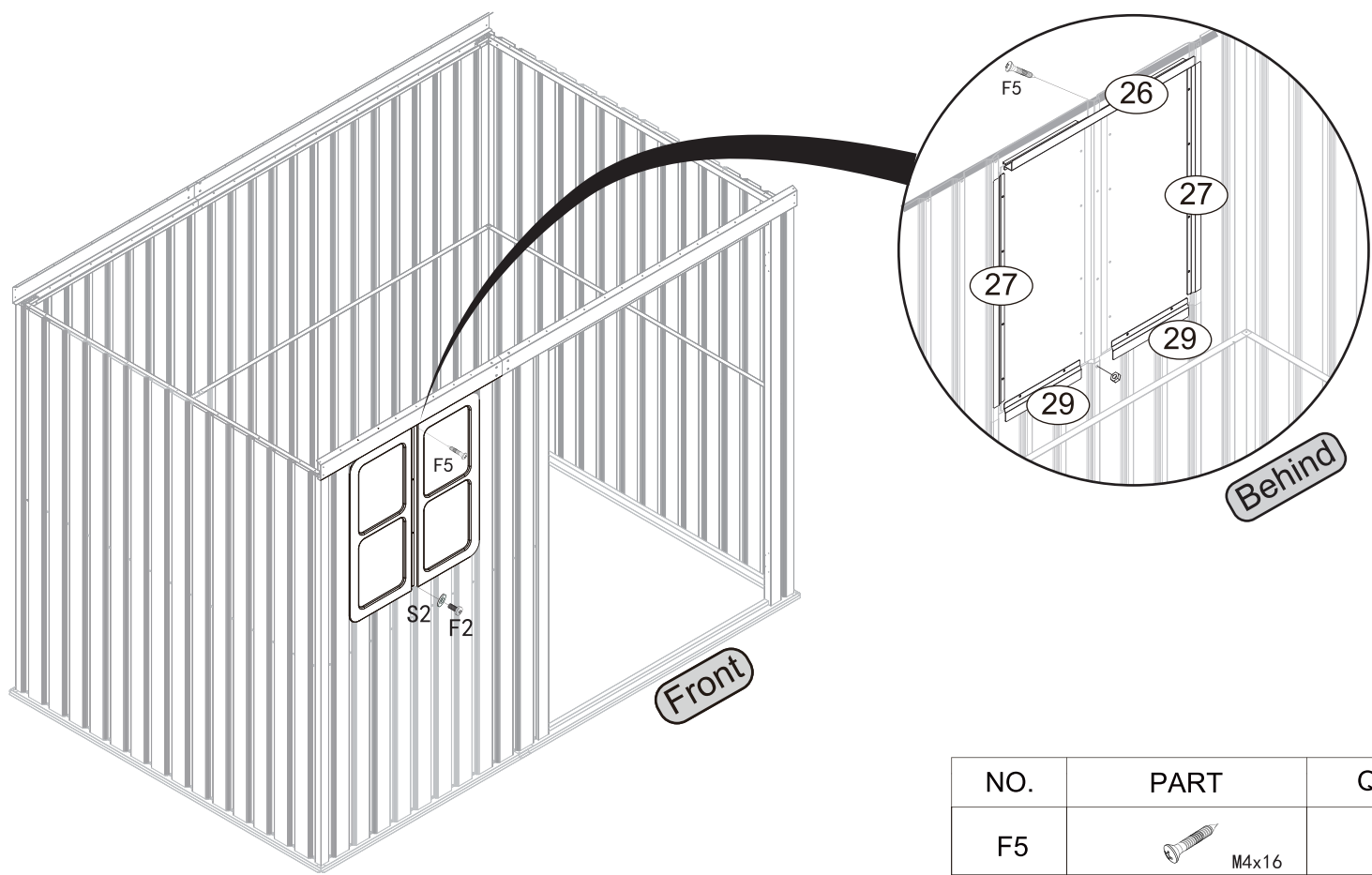
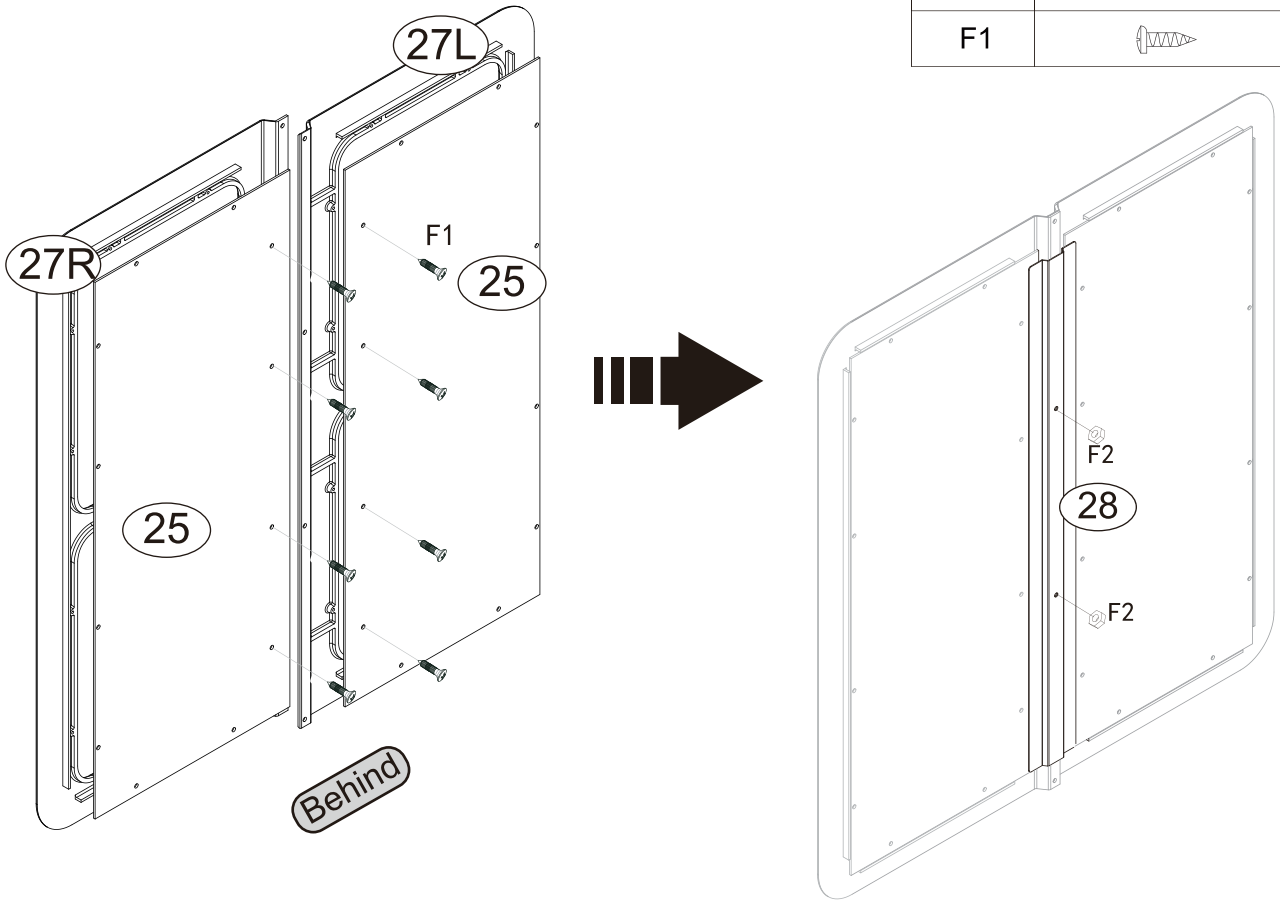

Do not install 26,27,29 in this one.

NO.	PART	Qty.
F2		2
F1		8



NO.	PART	Qty.
F5	 M4x16	1
F2		1
S2		1

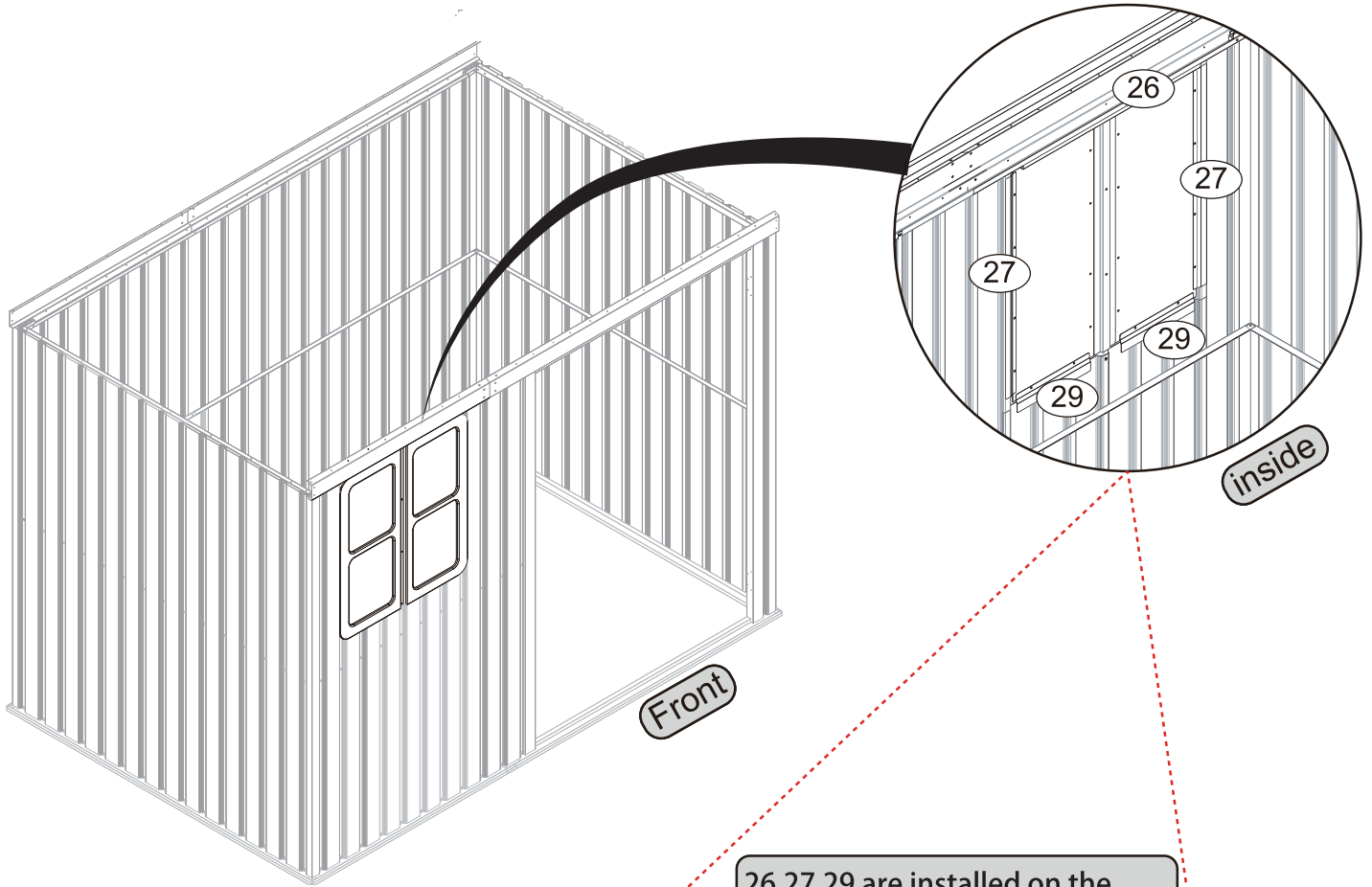

26,27,29 are installed on the upper level of the window panel

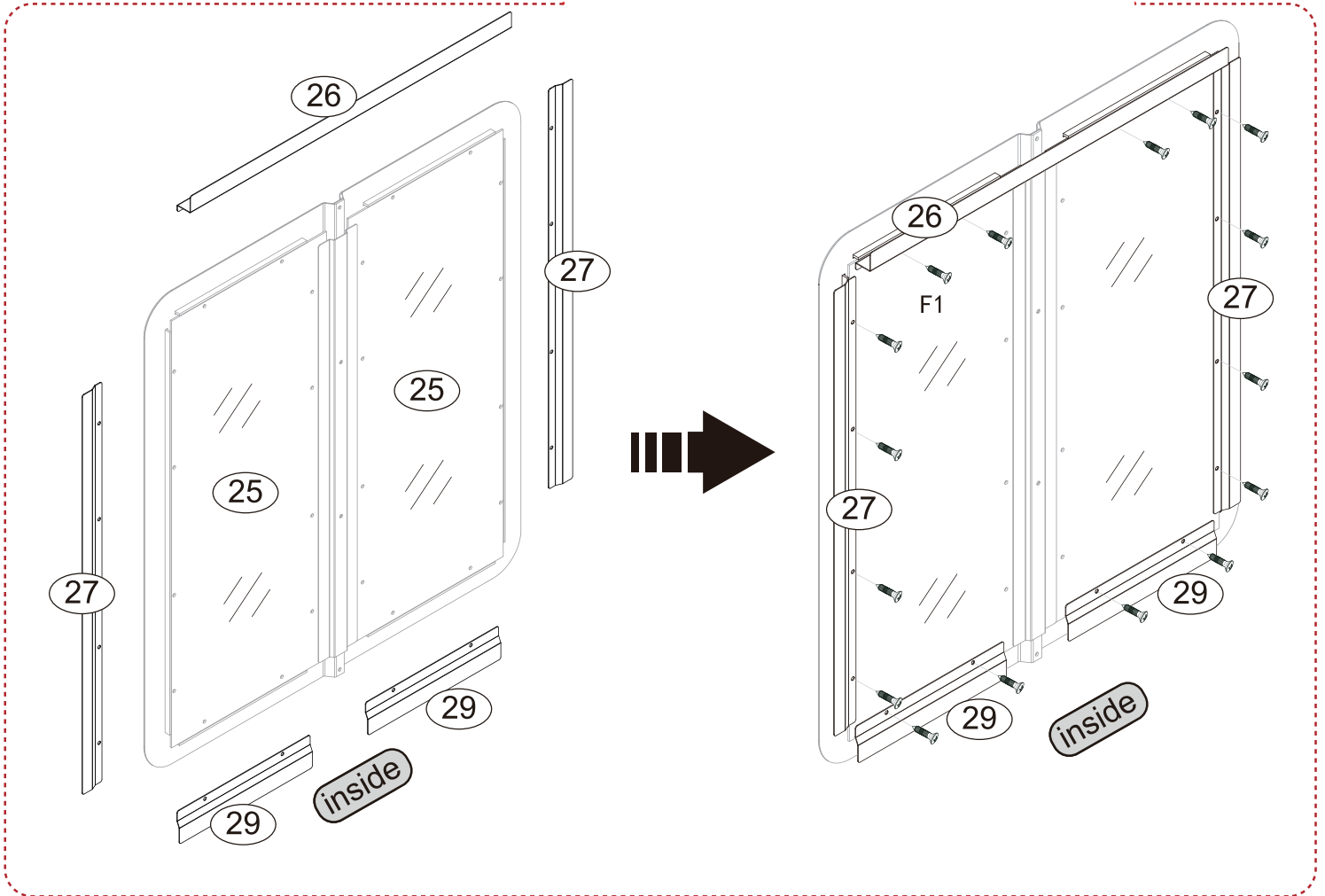

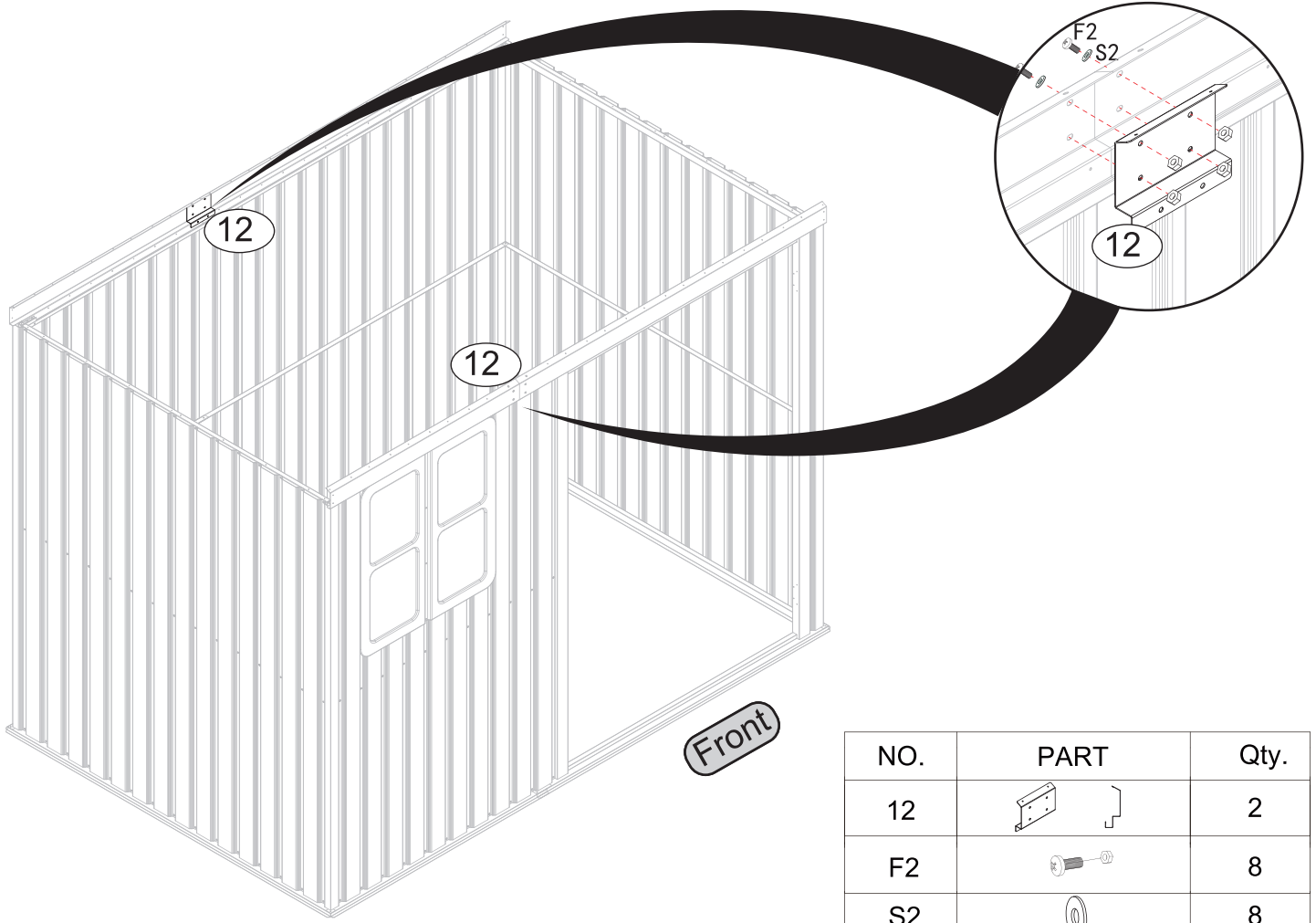



NO.	PART	Qty.
12		2
F2		8
S2		8

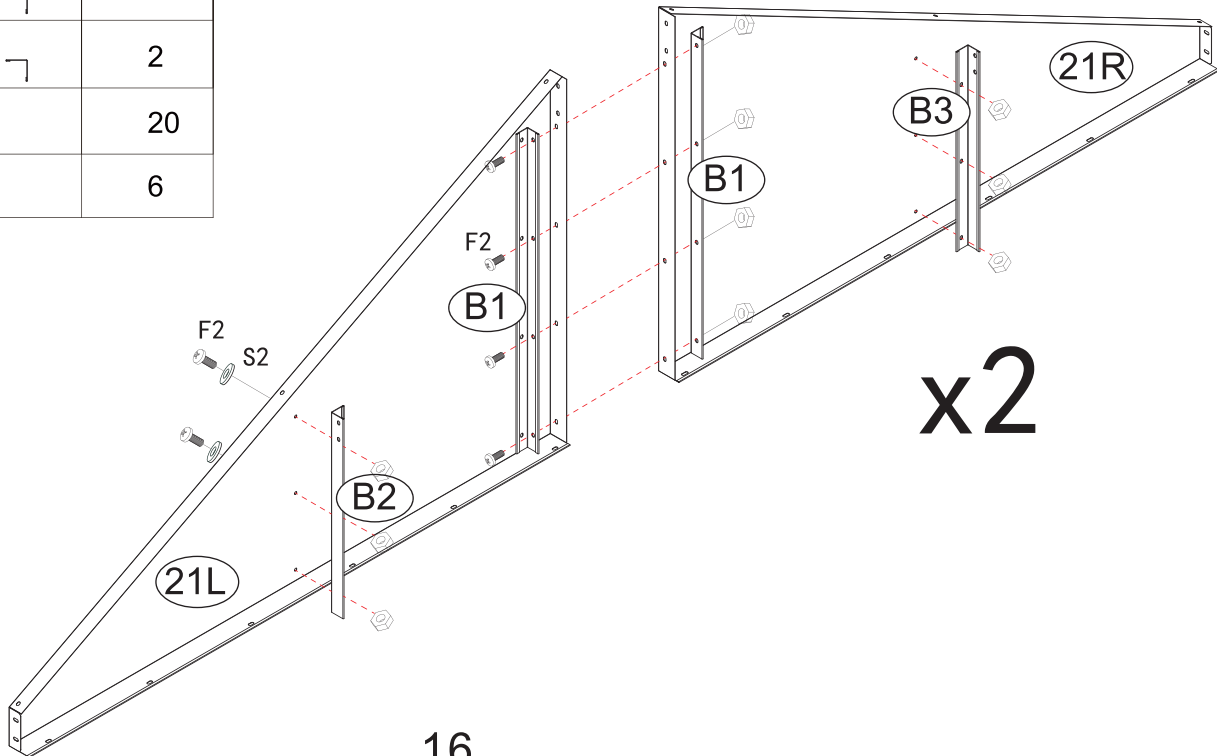

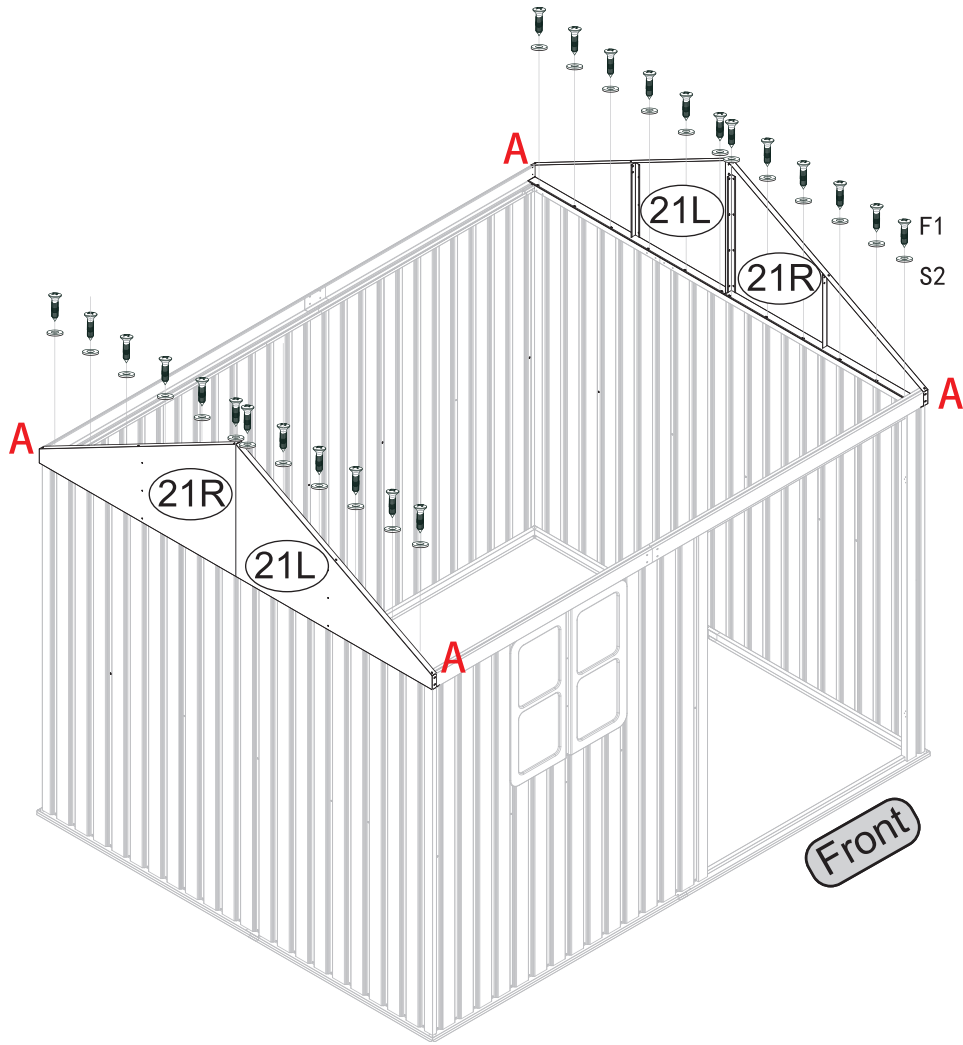
NO.	PART	Qty.
21L		2
21R		2
B1		4
B2		2
B3		2
F2		20
S2		6



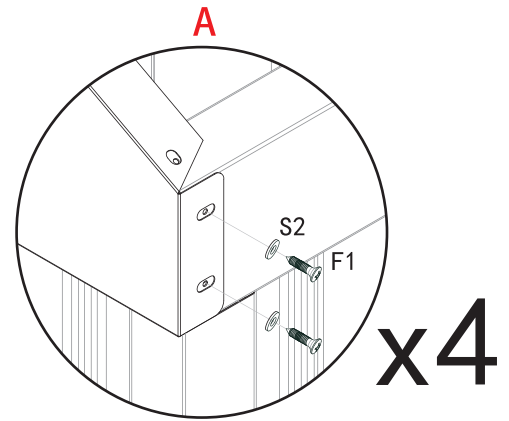

NO.	PART	Qty.
F1		32
S2		32



NO.	PART	Qty.
13		2
14		2

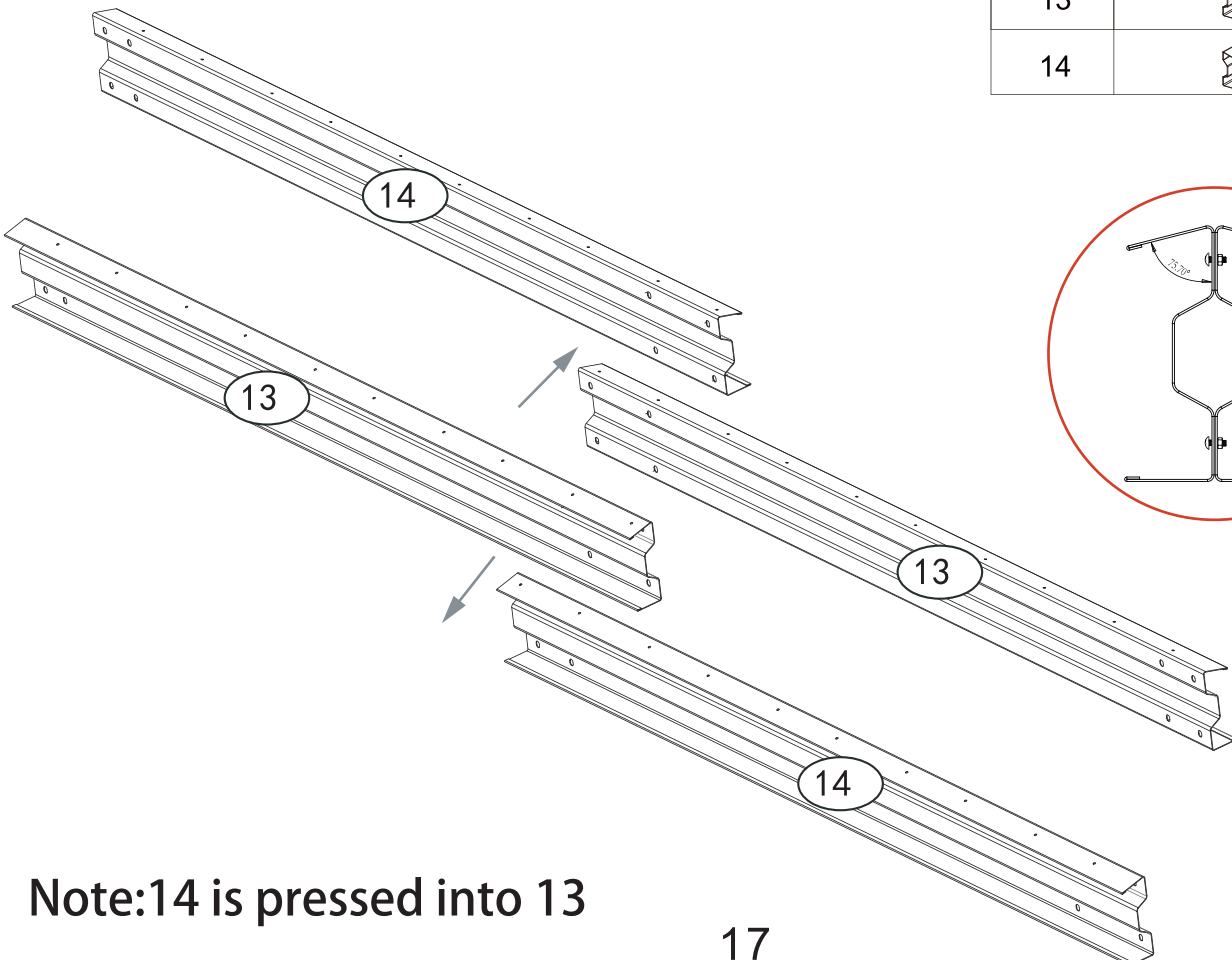

Note: 14 is pressed into 13

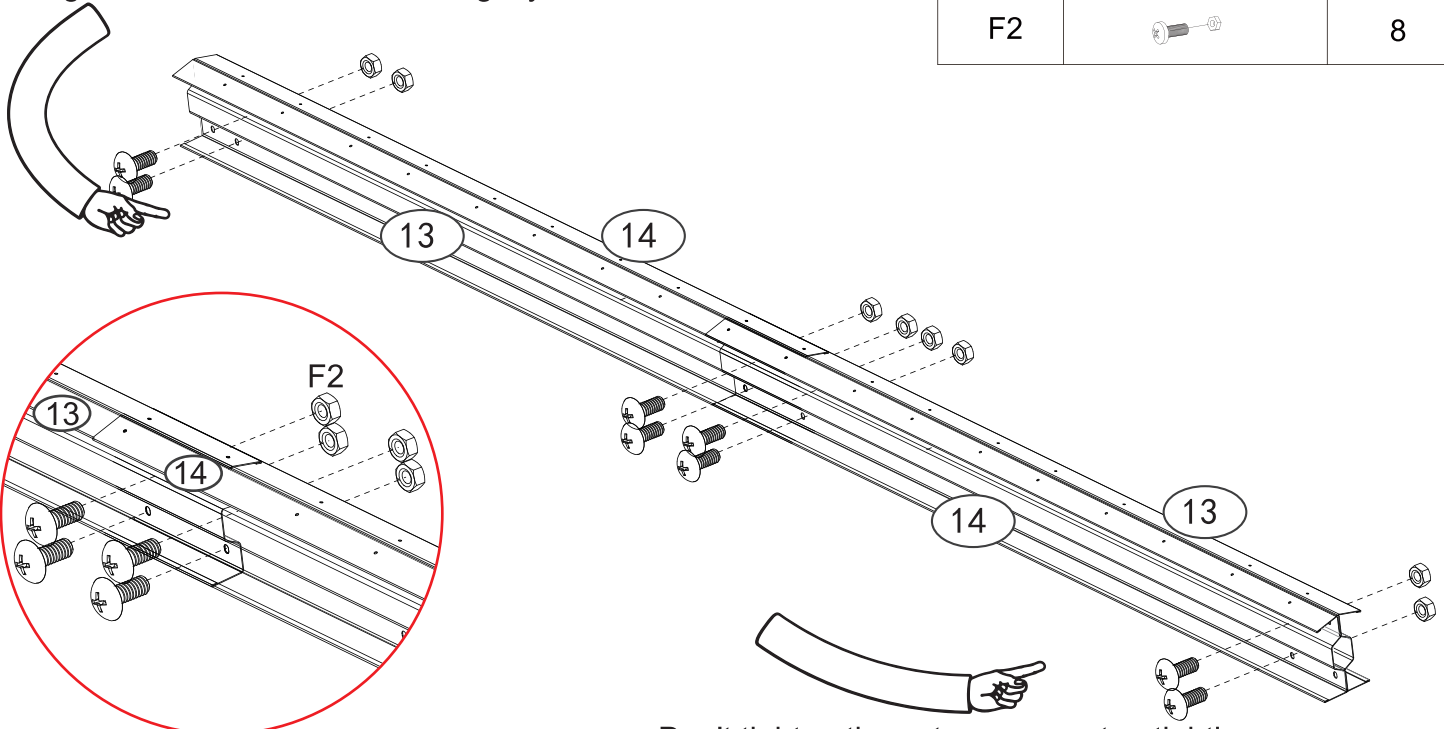

Don't tighten these two screws too tightly

NO.	PART	Qty.
F2		8

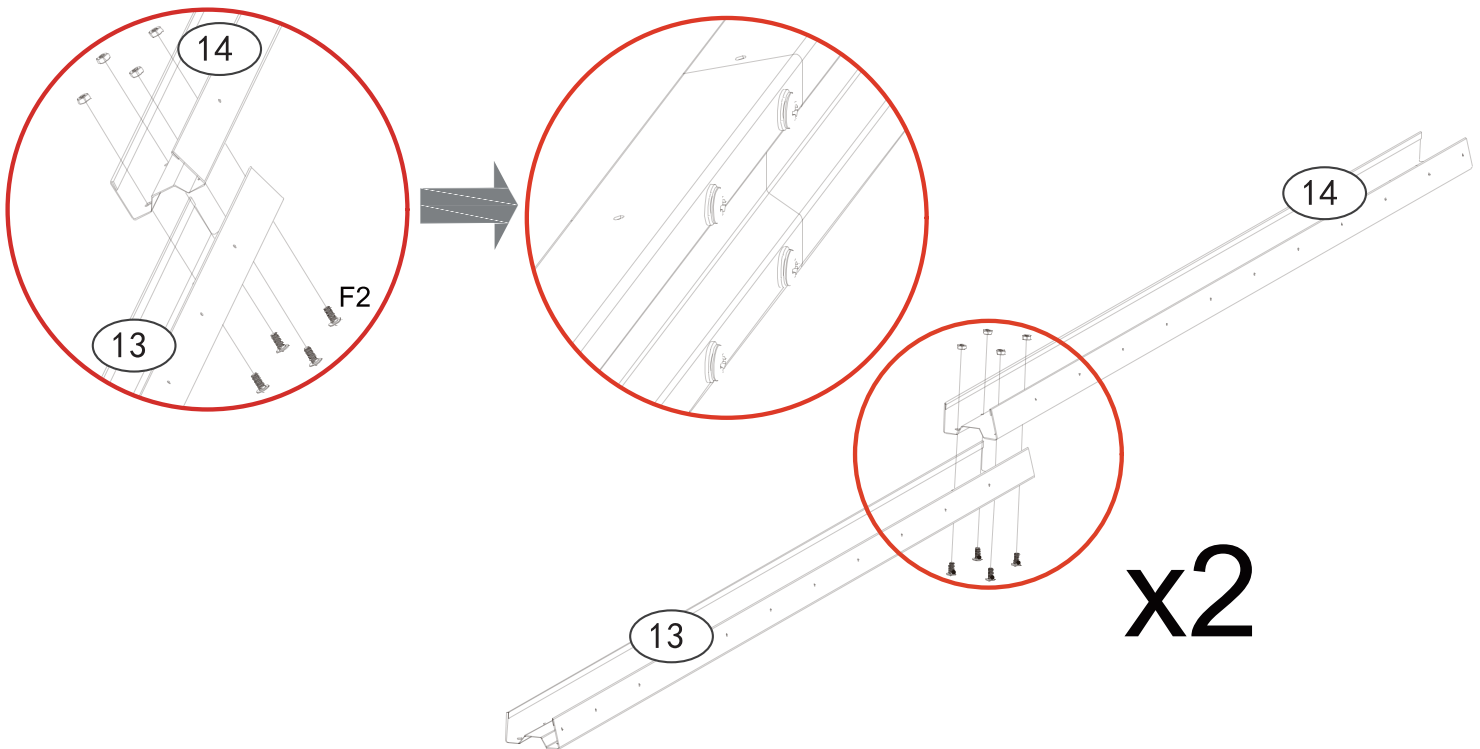

Don't tighten these two screws too tightly



NO.	PART	Qty.
13		2
14		2
F2		8

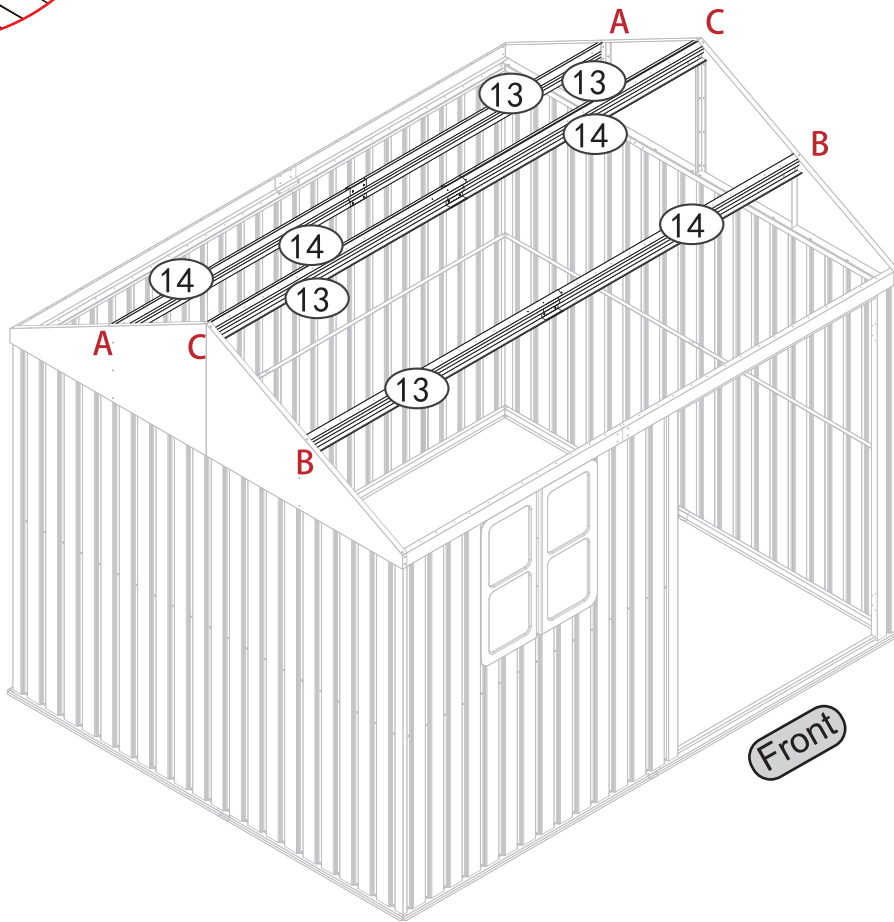
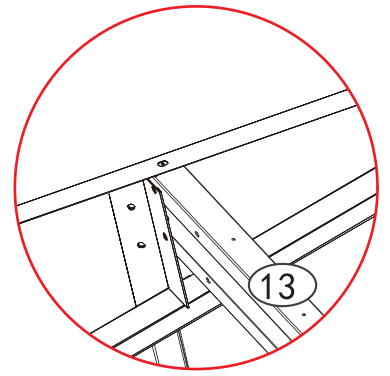
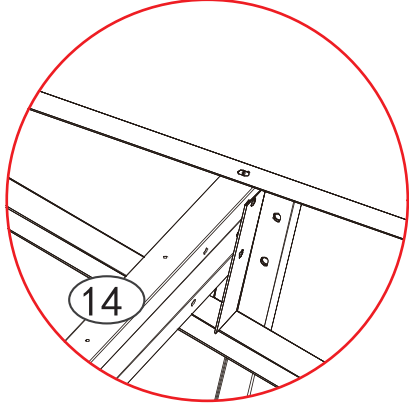
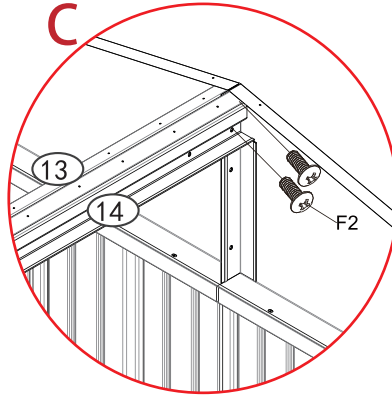
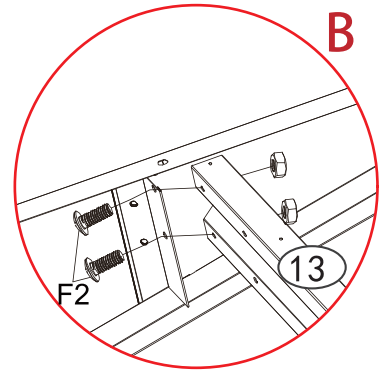
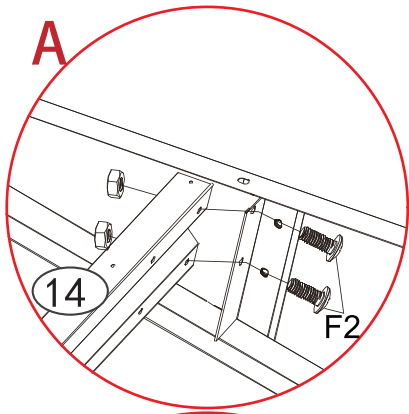

NO.	PART	Qty.
F2		12

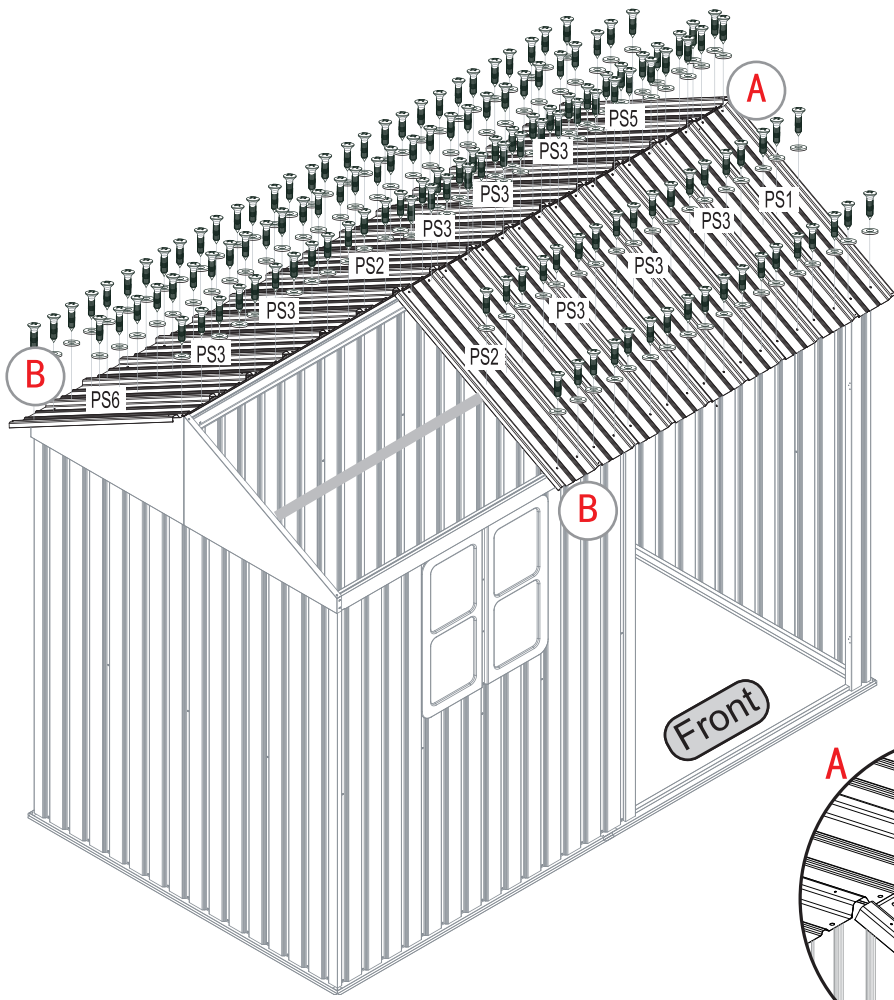

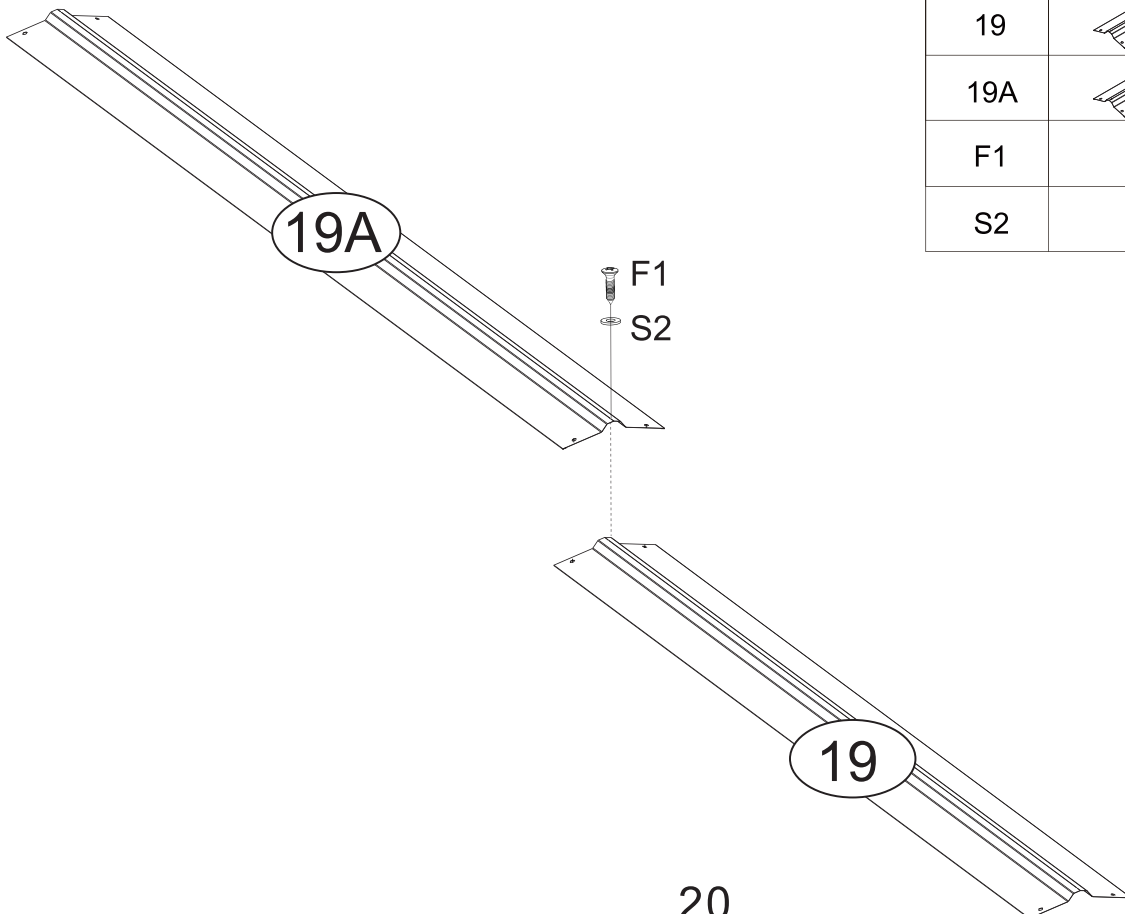
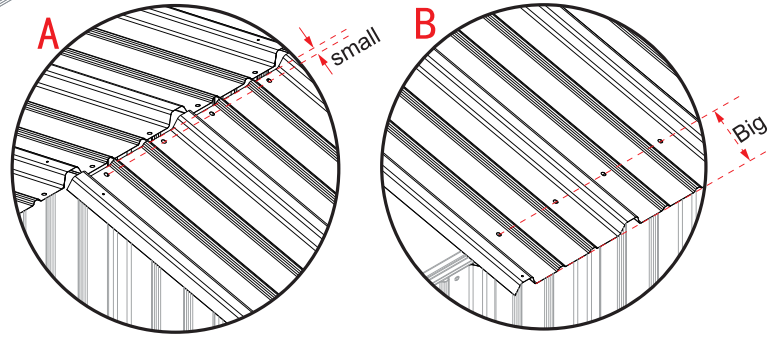

NO.	PART	Qty.
PS1		1
PS2		2
PS3		8
PS5		1
PS6		1
F1		153
S2		153



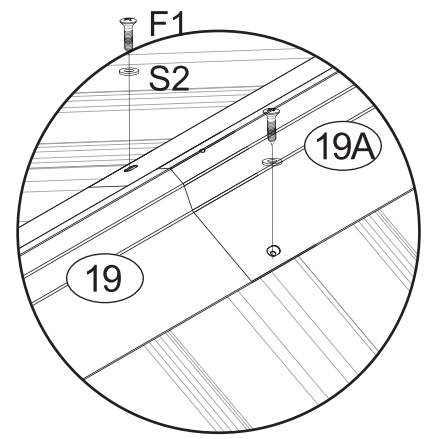
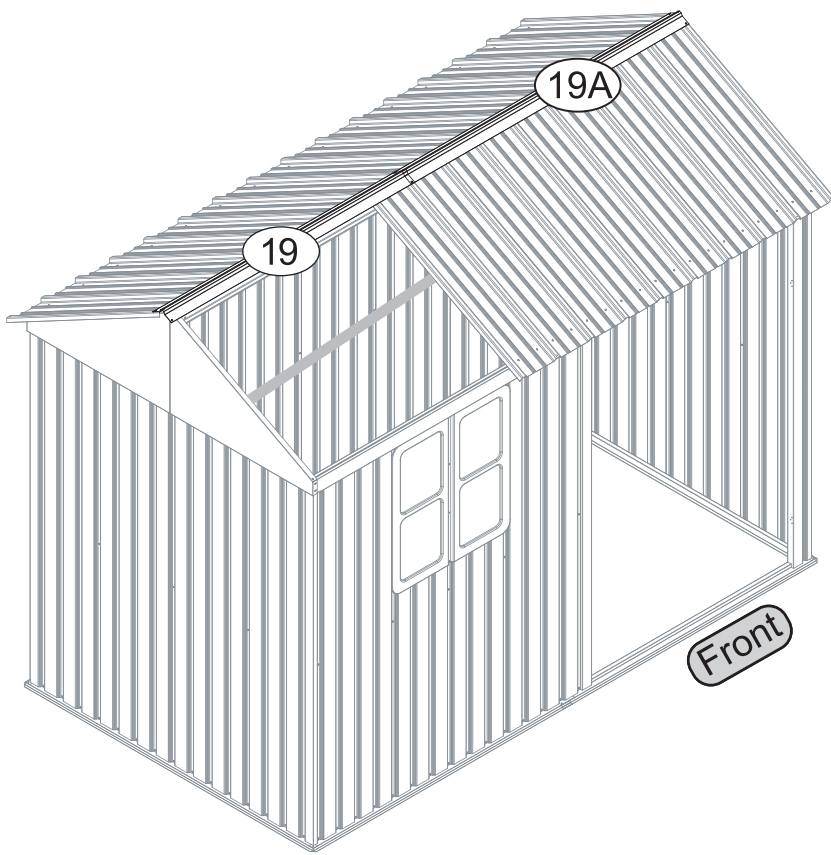

NO.	PART	Qty.
19		1
19A		1
F1		1
S2		1

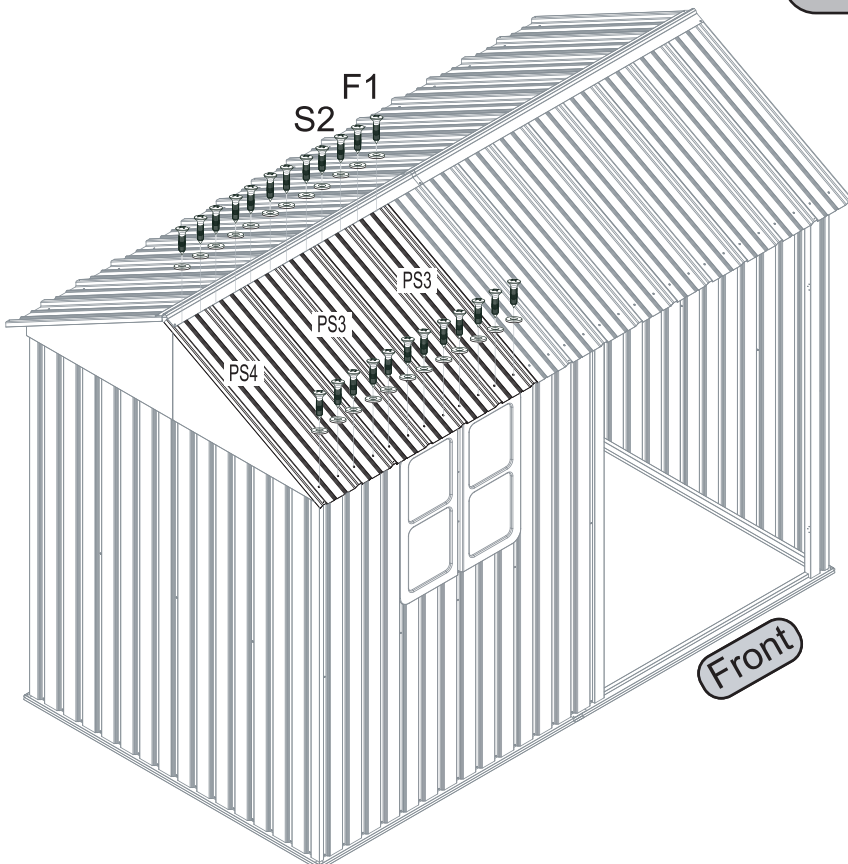

NO.	PART	Qty.
F1		2
S2		2

Lift up 19 and install PS1

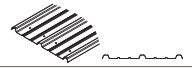
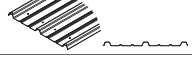

NO.	PART	Qty.
PS3		2
PS4		1
F1		24
S2		24

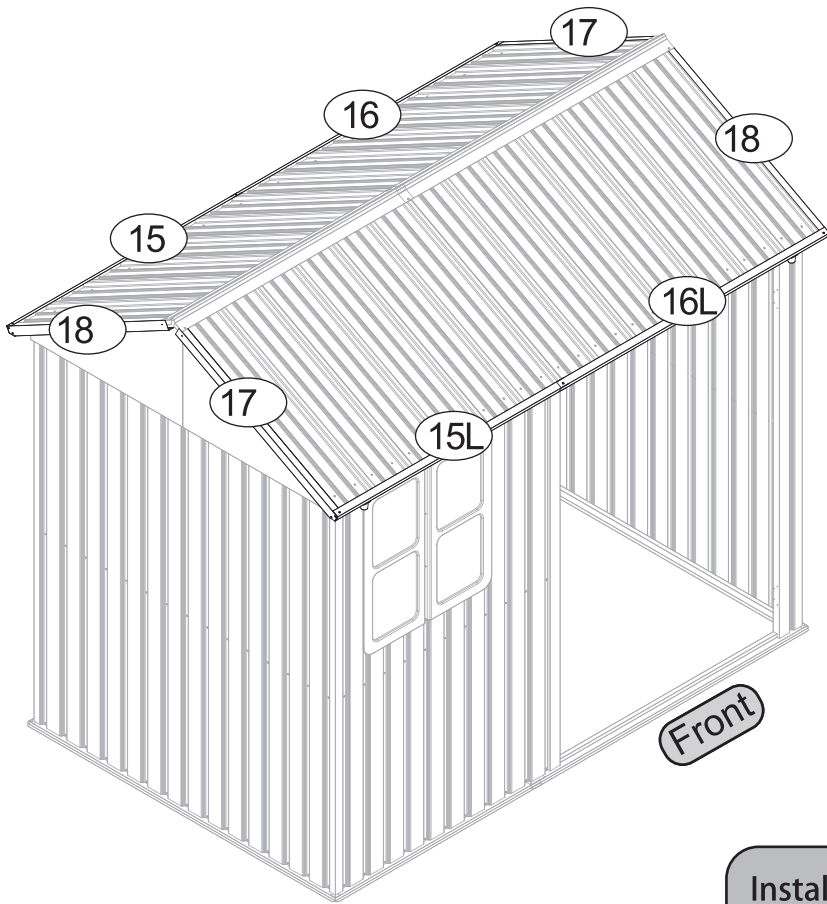





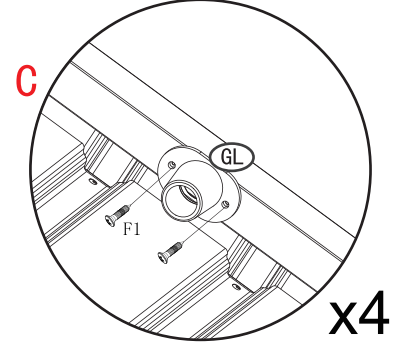
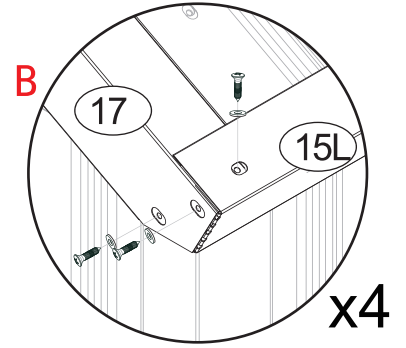
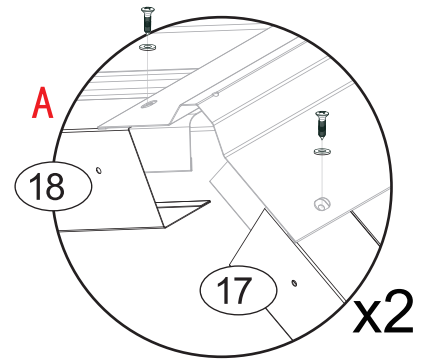
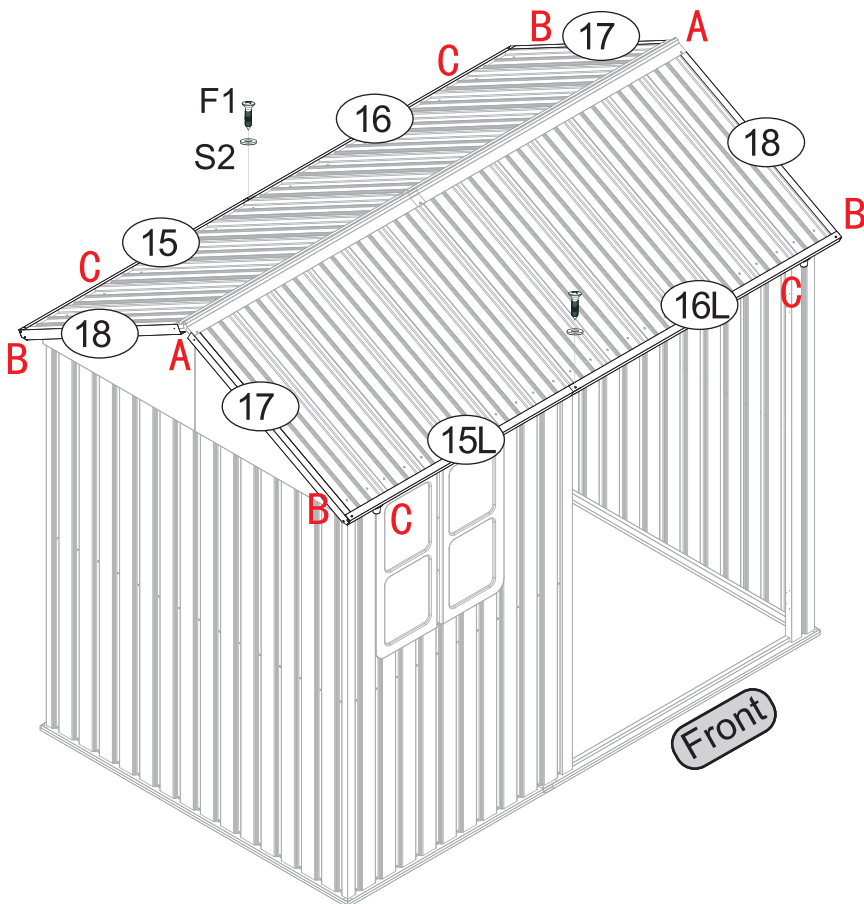

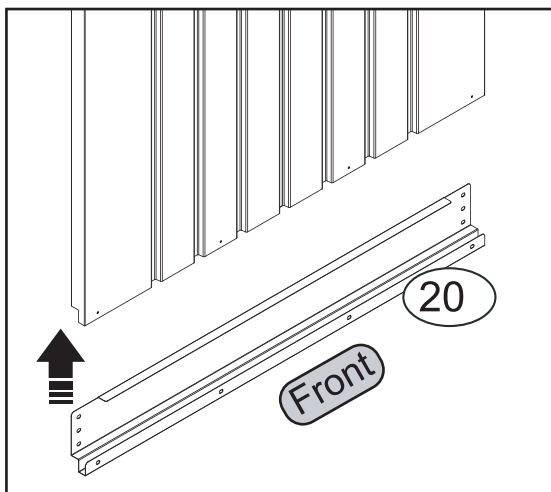
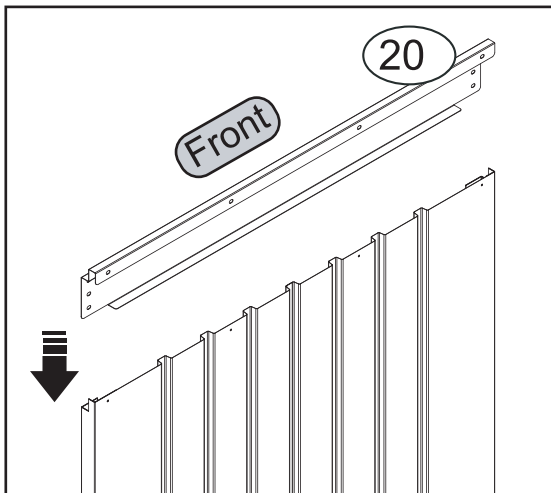
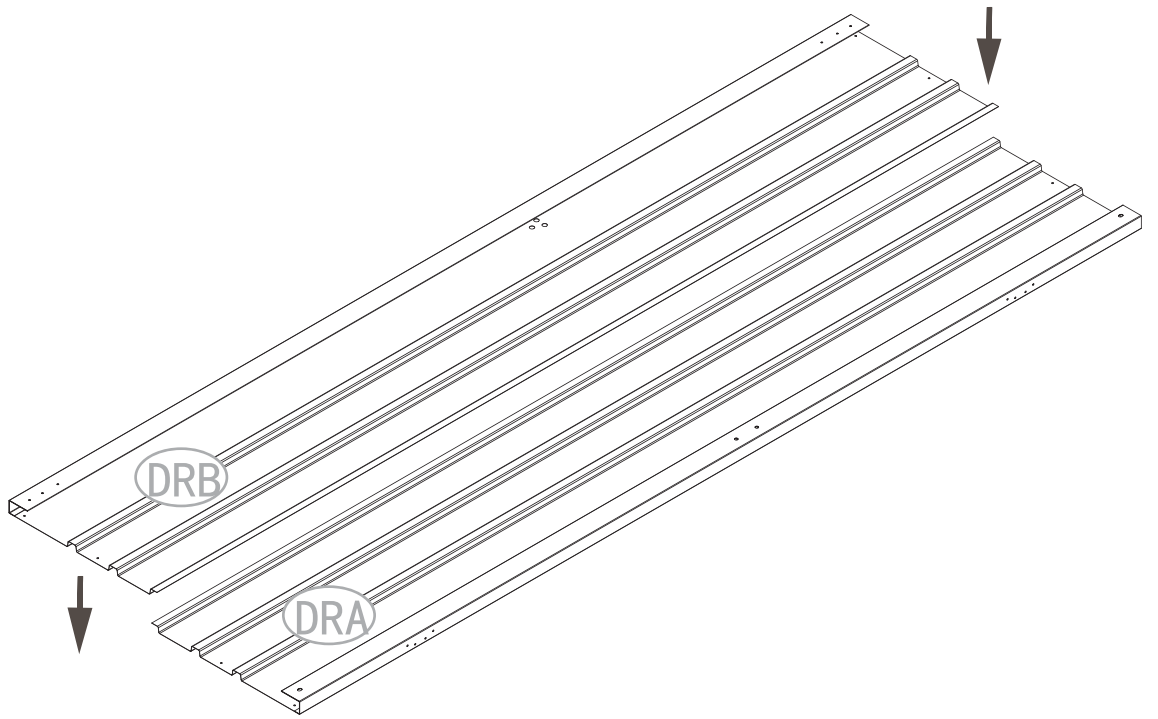
NO.	PART	Qty.
15		1
16		1
17		2
15L		1
16L		1
18		2
GL		4
F1		26
S2		26

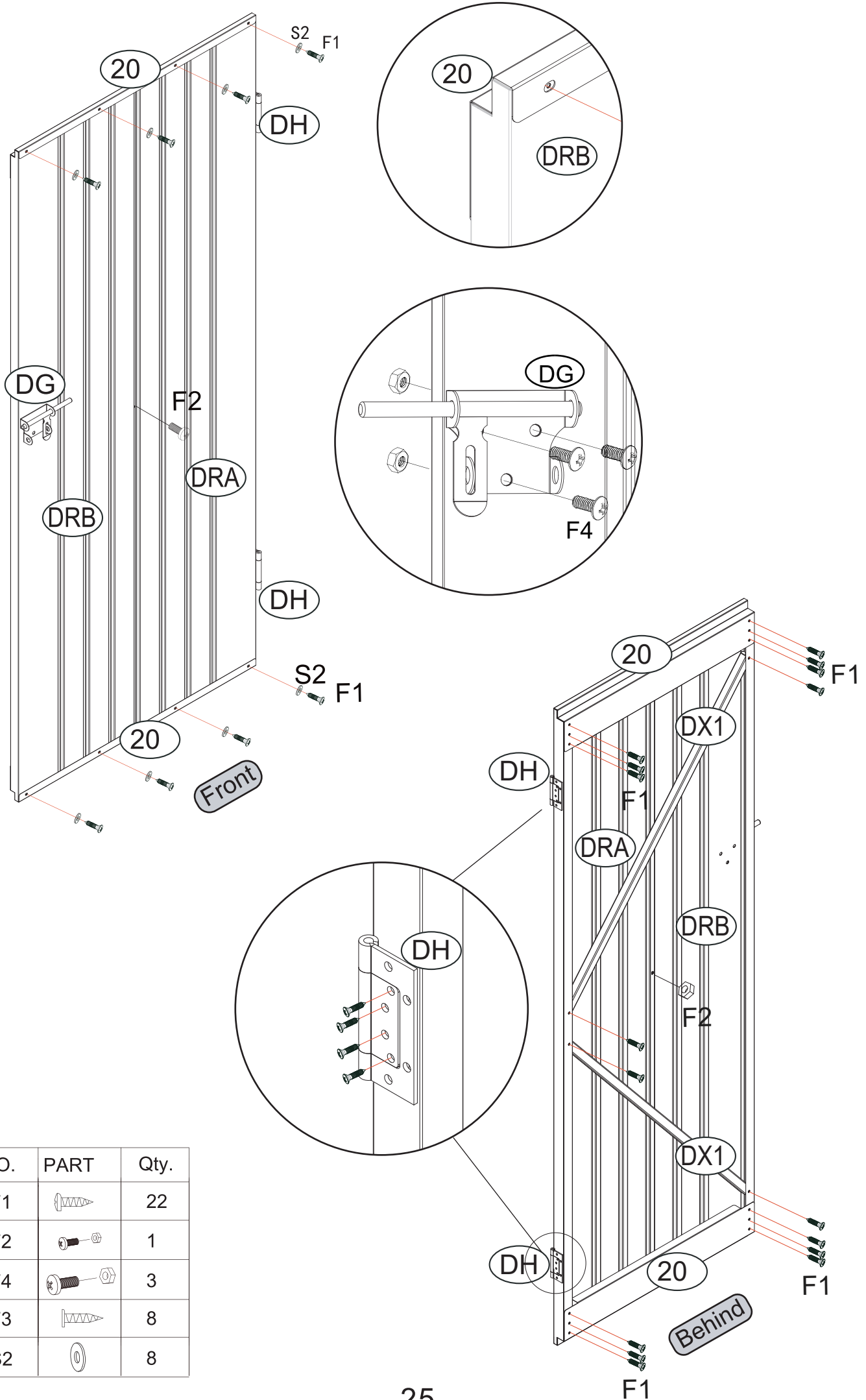
Installation steps can be found on the next page







NO.	PART	Qty.
F1		22
F2		1
F4		3
F3		8
S2		8

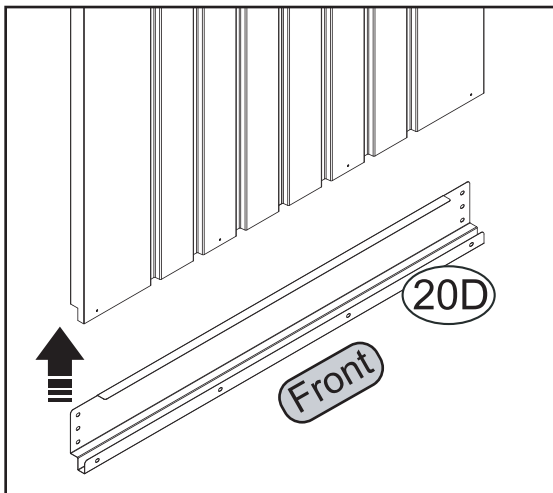
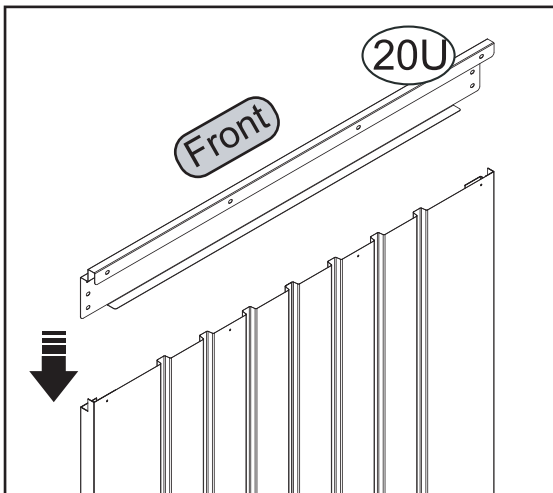
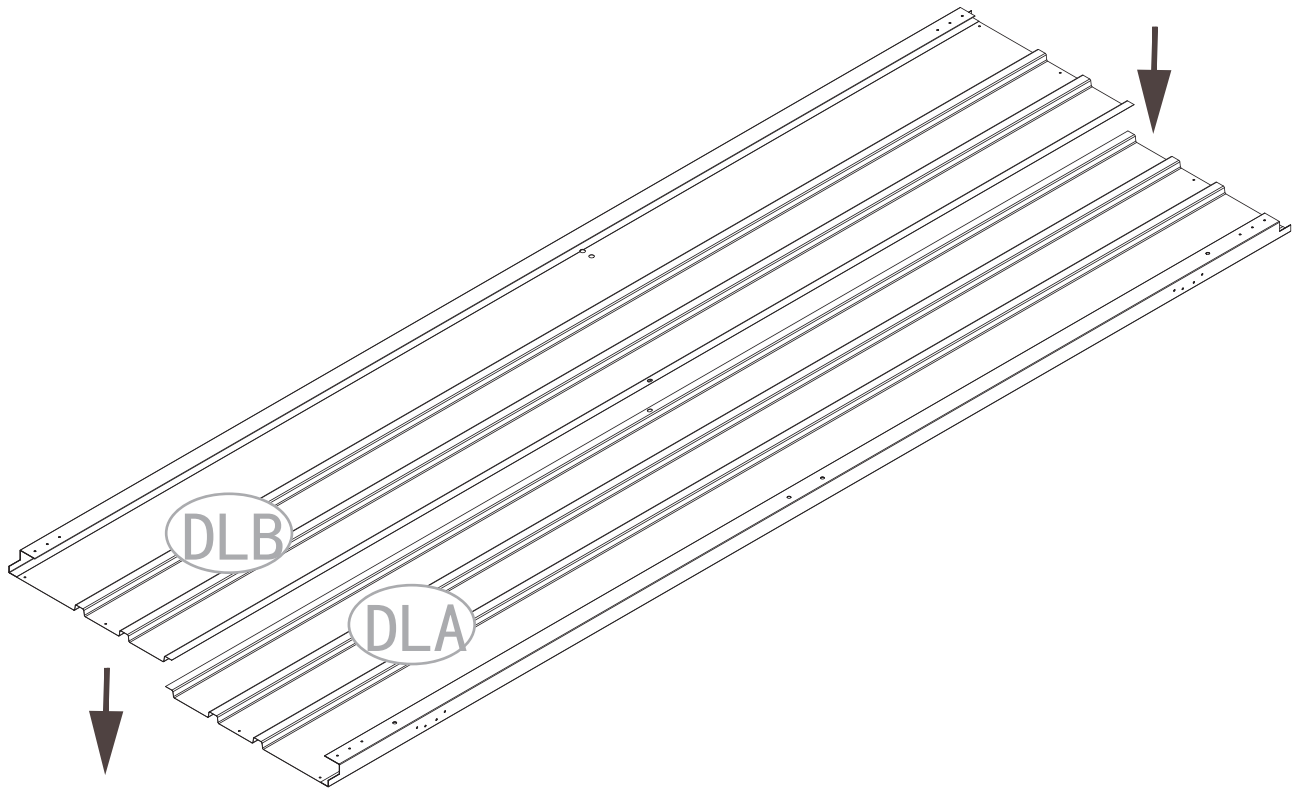

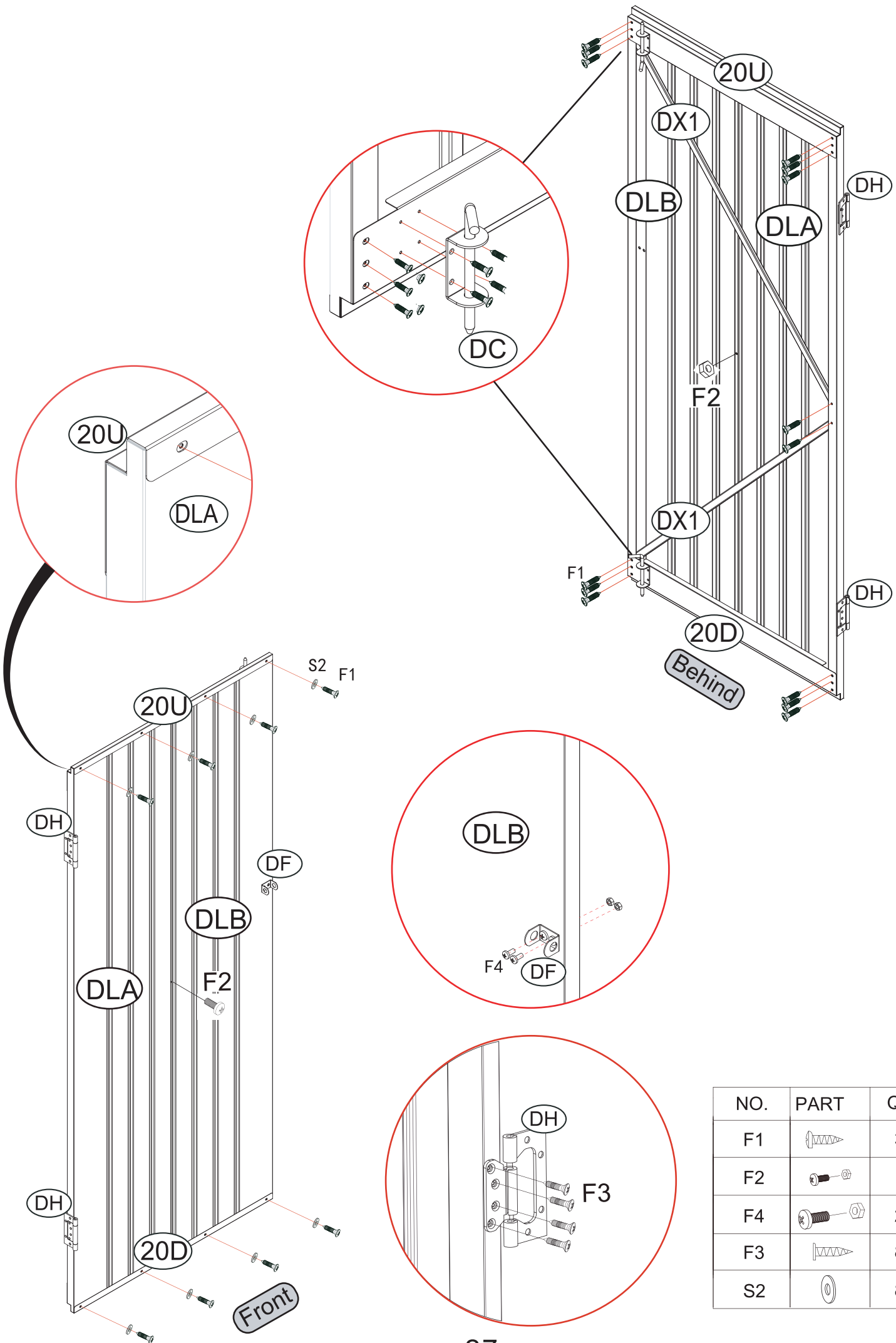

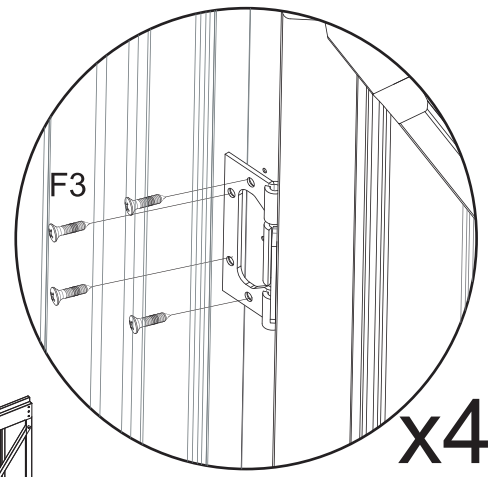
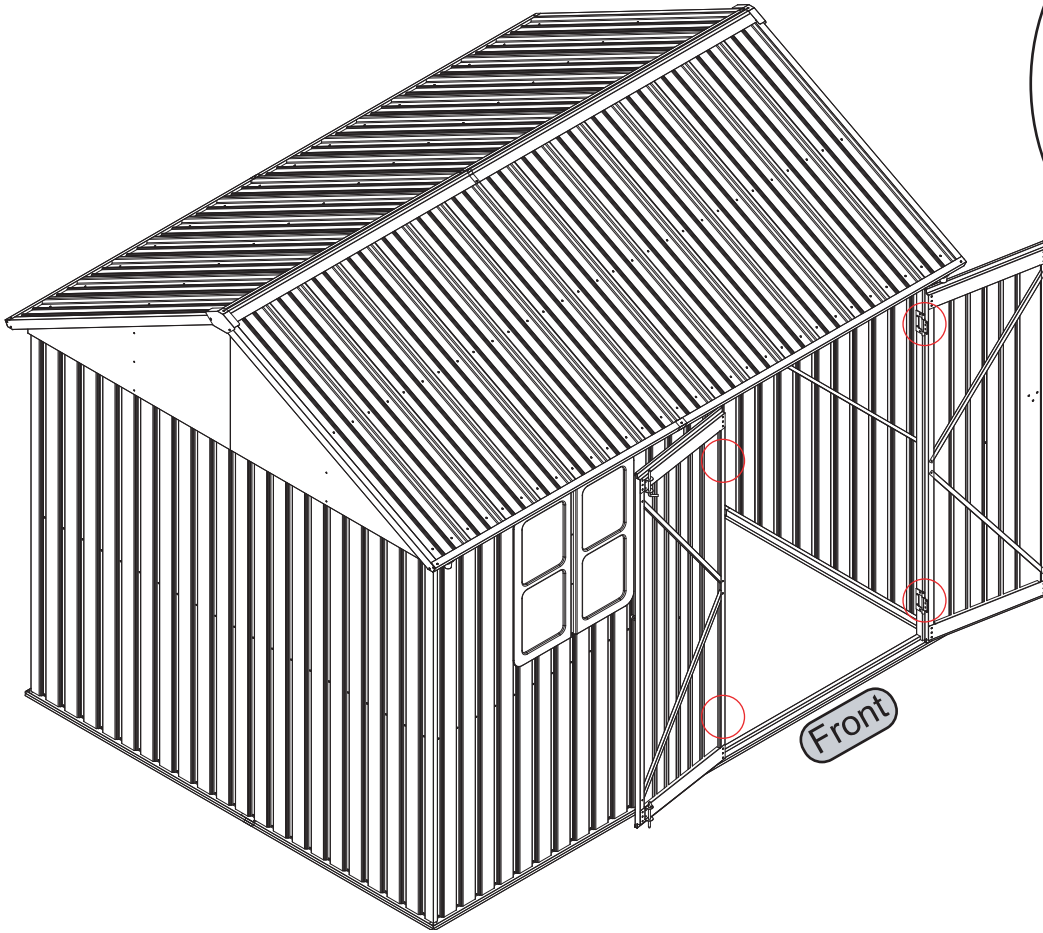

NO.	PART	Qty.
F1		30
F2		1
F4		2
F3		8
S2		8

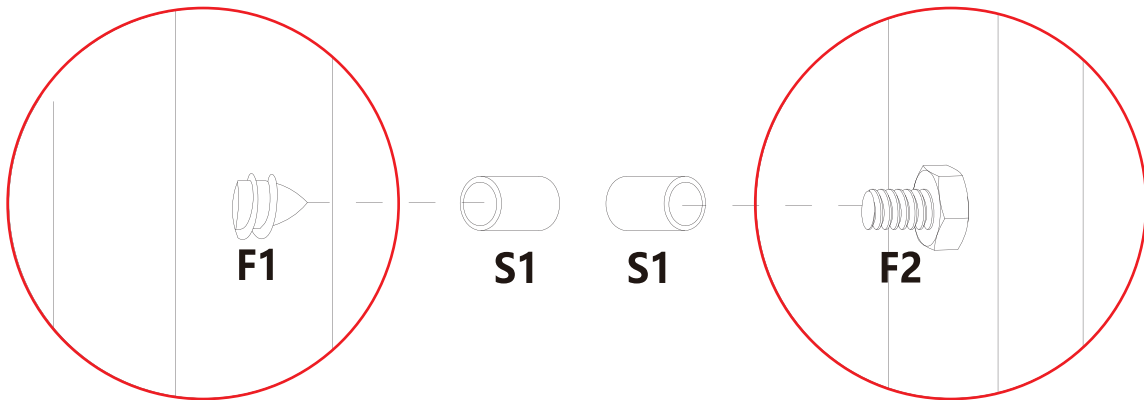

x4

Parts	No	Qty
	F3	16



Parts	No	Qty
	S1	

