

User's Manual

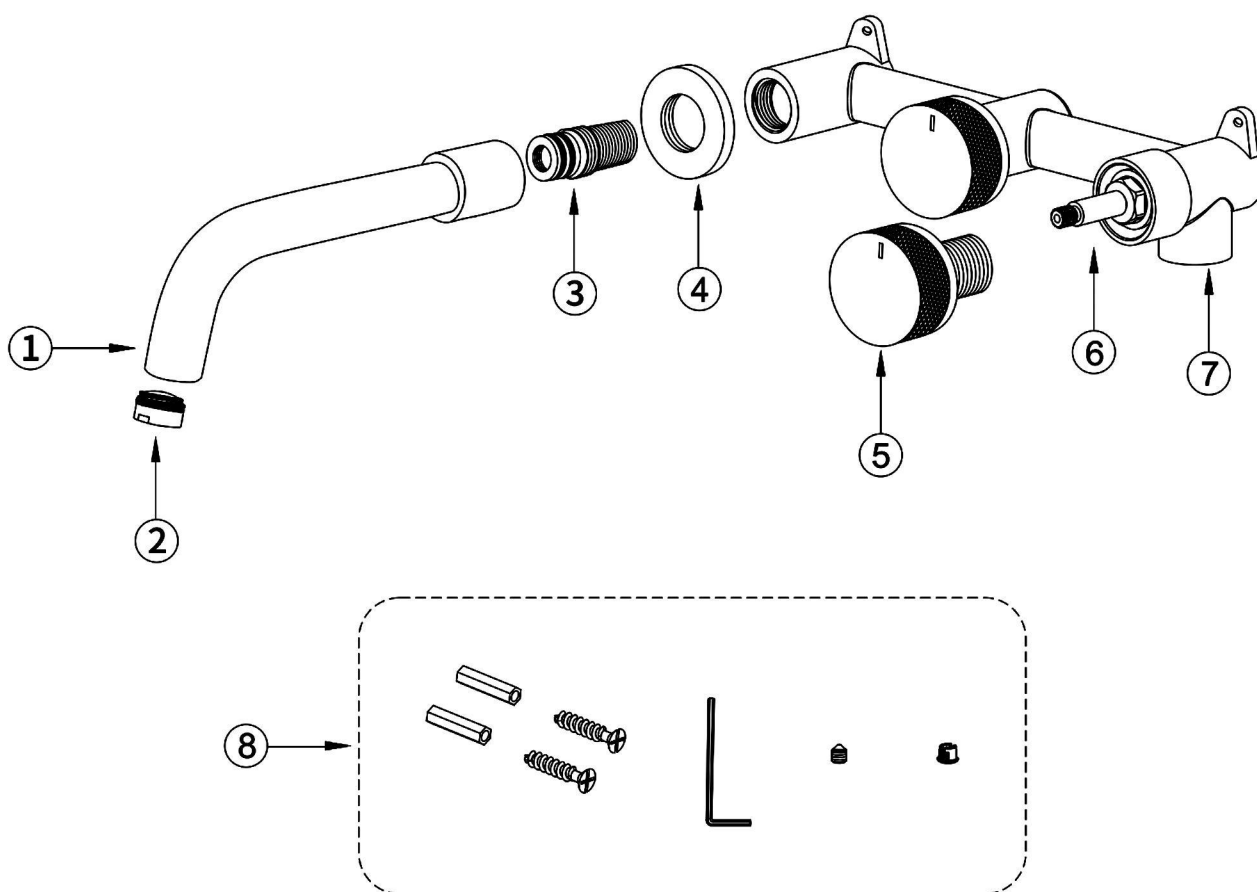

BEFORE INSTALLATION

NO.	Item	Qty
1	Spout	1
2	Aerator	1
3	Water inlet joint	1
4	Decorative cup	1
5	Handle	2
6	Valve	2
7	Main body	1
8	Accessory bag	1



Check accessories

Standard List of Accessories:

When you open the product packaging, please check whether the objects in it are consistent with the main body and accessories you purchased. If there is any inconsistency, please contact our company or our distributor.

Note: 1. Accessories are subject to change without prior notice if the change does not affect usage;

2. The appearance of the product is subject to the physical objects you receive, and the schematic diagram is only for reference.

INSTALLATION STEPS

This product has been inspected and debugged by the factory to the best condition. Please do not disassemble and assemble it yourself.

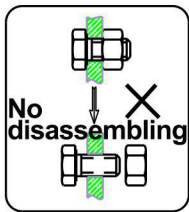

Before installing the product, please be sure to remove sundries and sludge from the water pipe to prevent sundries from blocking the product.



1. Dig pipe grooves for pre-burrying pipes.
2. Install the main body and water inlet.

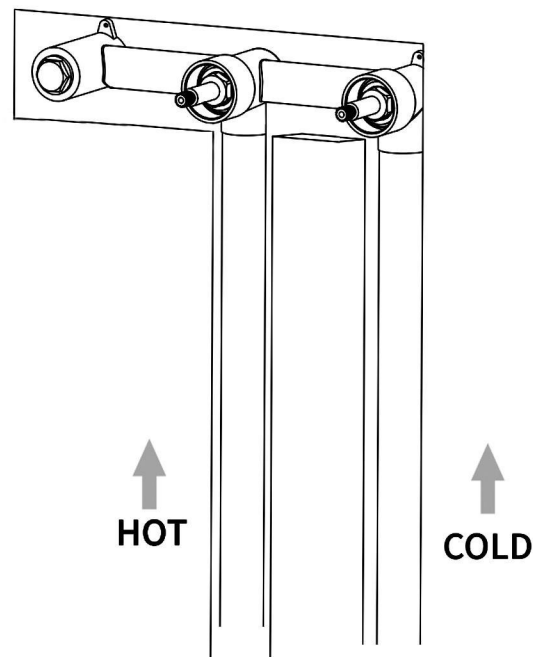
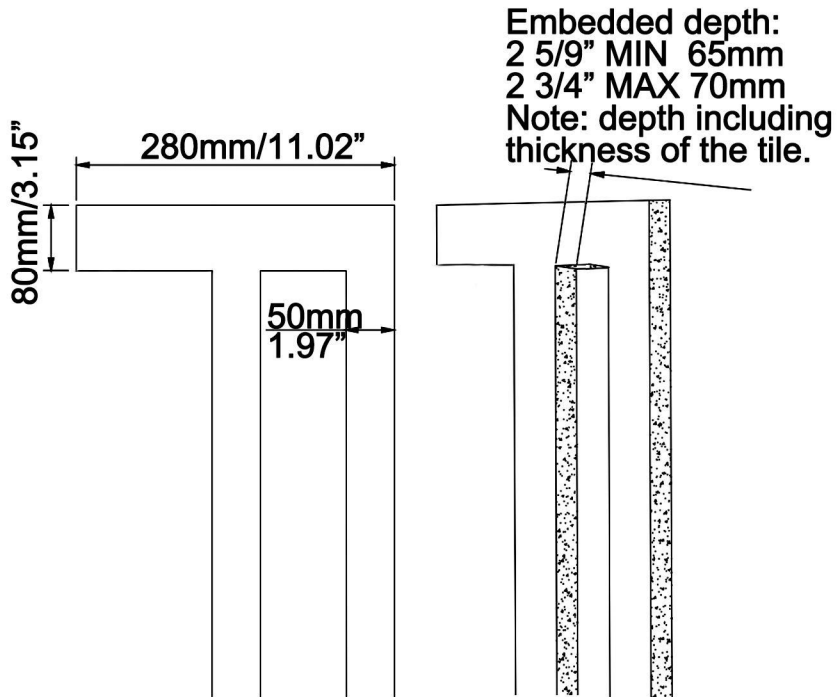

3. Fixed with self-tapping screws faucet body.

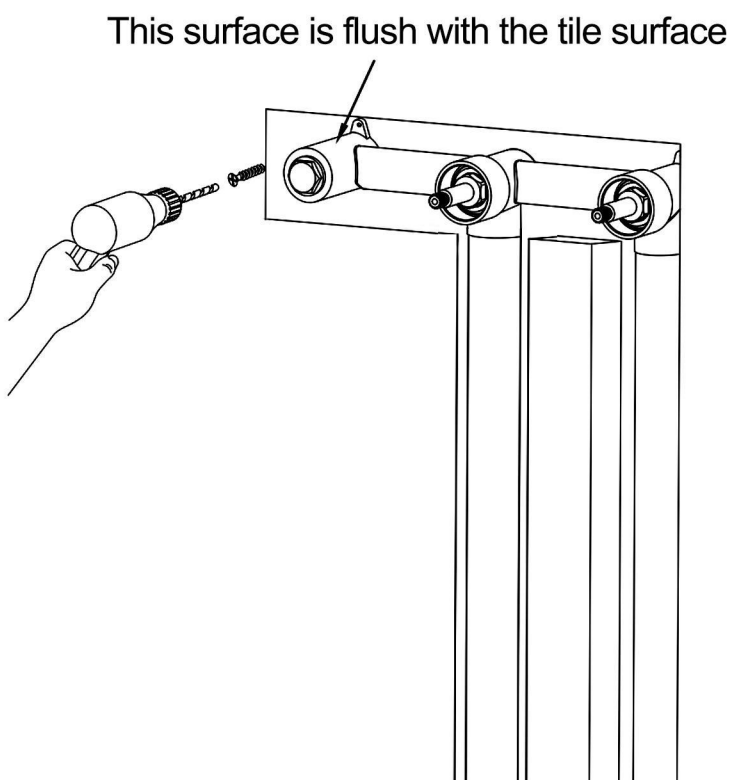

4. Tile tiling good state.

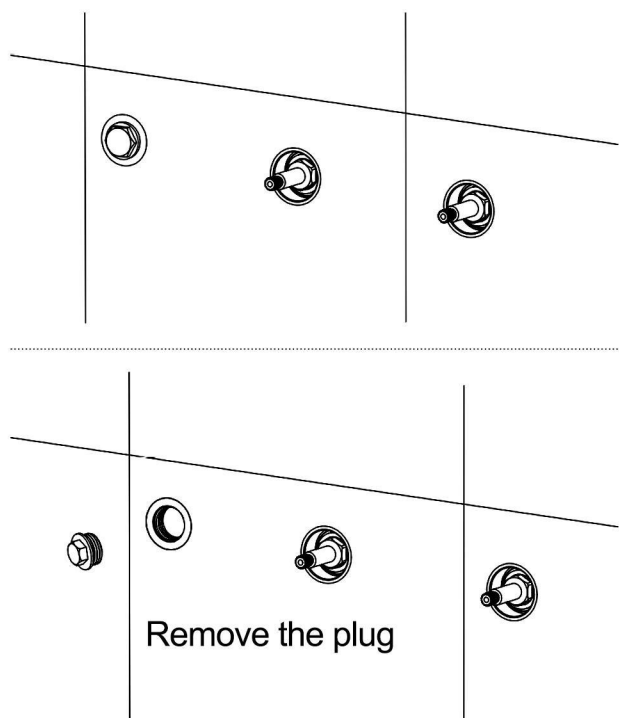

INSTALLATION STEPS

5. Install the spout.
(Wrap the PTFE tape on the thread)

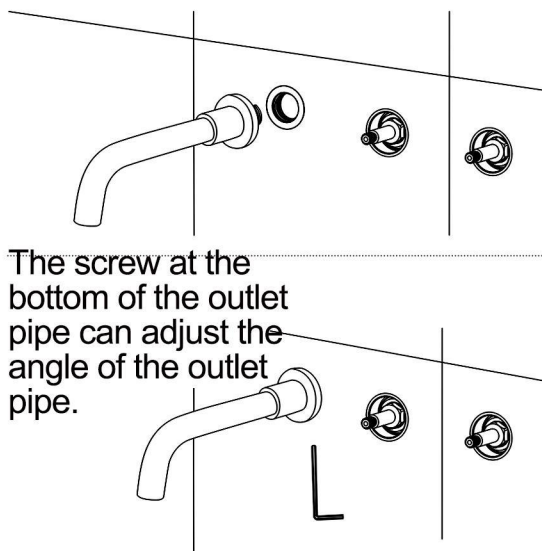

6 Install panels and handles.

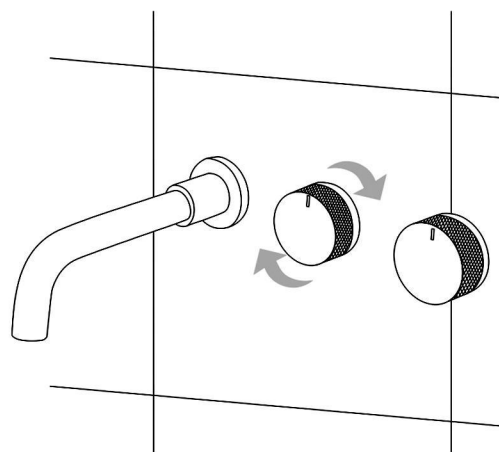

Product Size

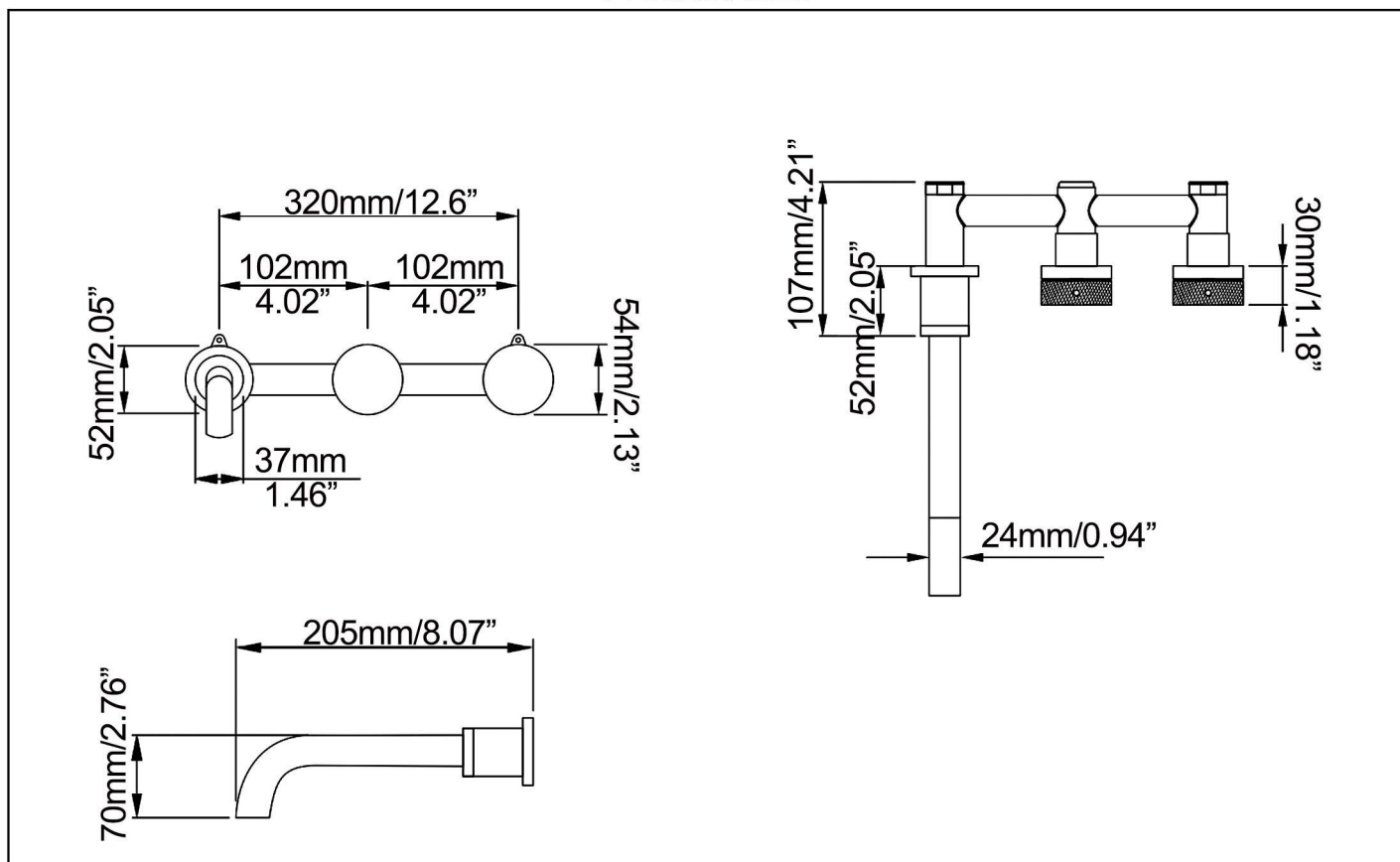

CLEANING CARE

In order to keep the appearance of product clean, bright and good performance, please take care of the product as follows;

1. Rinse with water only and dry with soft cotton cloth;
2. Use mild liquid and colorless glass cleaner to remove surface dirt and scale film, or use polish without abrasive effect;
3. Do not use abrasive detergent, polish, emery cloth, paper towel or scraper, etc;
4. Do not use acid cleaner, or cleaner and soap with insoluble gran etc;
5. In the process of use, mud may accumulate in the bubbler and make the water flow show, The bubbler can be unscrewed, rinsed with water, and then installed back in place.

