

# ASSEMBLY INSTRUCTIONS

Thank you for purchasing this quality product. Be sure to check all packaging materials carefully for small parts that may have come loose inside the carton during shipment.



## Reminders

1. Use only the hardware supplied.
2. Do not over-tighten bolts.
3. This item may require periodic tightening.

Caution: Please read instructions thoroughly before unpacking assembly parts. Sharp, exposed staple tips can cause injury. Therefore, for your protection, please remove any exposed staples used in packing. Please keep all hardware parts out of the reach of children.



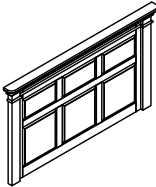
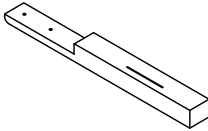
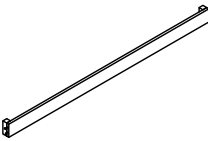
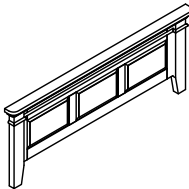
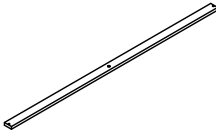

1. We recommend that you should assemble this product with the assistance of another person; this will make assembly easier and will help to eliminate damage to the product or injury to persons during assembly.
2. Be sure to check all packing materials carefully for small parts that may have come loose inside the carton during shipment.
3. Please do not over tighten screws or bolts.
4. Please put all parts on a non-abrasive floor before assembly, and follow the assembly steps to assemble your newly purchased product correctly and efficiently.

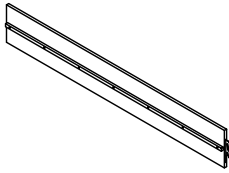
Note: Bunkie Board must be used to replace box spring

COMPONENTS LIST		QTY
A	Head Board 	1pc
B	Bed Leg Left- Right 	2pcs
C	Stretcher 	1pc
COMPONENTS LIST		QTY
D	Foot Board 	1pc
E	Slats 	5pcs
F	Support Leg 	5pcs
G	Adjustable Leveler 	5pcs

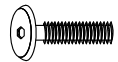
COMPONENTS LIST		QTY
H	Side Rail 	2pcs

## Hardware List :

NO	DESCRIPTION	SIZE	FIGURE	QTY
1	Short Bolt	Ø5/16"x 57mm		8pcs
2	Spring Washer	Ø5/16"x 12mm		8pcs
3	Flat Washer	Ø5/16"x 19mm		8pcs
4	Allen Key	58x 23x 4mm		1pc

## Hardware List :

NO	DESCRIPTION	SIZE	FIGURE	QTY
5	Screw	Ø8x Ø4x 32mm		10pcs

### IMPORTANT NOTE:

- Please keep all hardware parts out of the reach of children.
- Two or more people are needed for assembly.

# ASSEMBLY INSTRUCTIONS

## STEP 1:

Attached Bed Leg (B) to the Stretcher (C) using the provided hardware as shown on Fig.1.

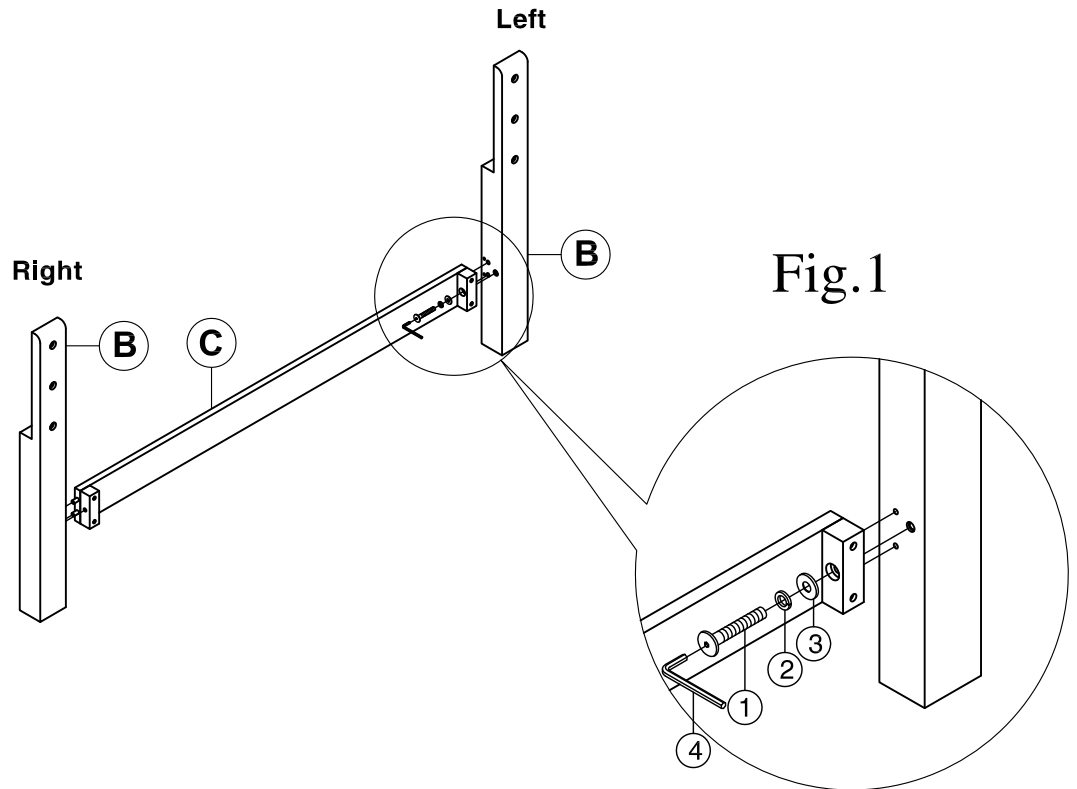

## STEP 2:

Attached Head Board (A) to the Bed Leg (B) using the provided hardware as shown on Fig.2.

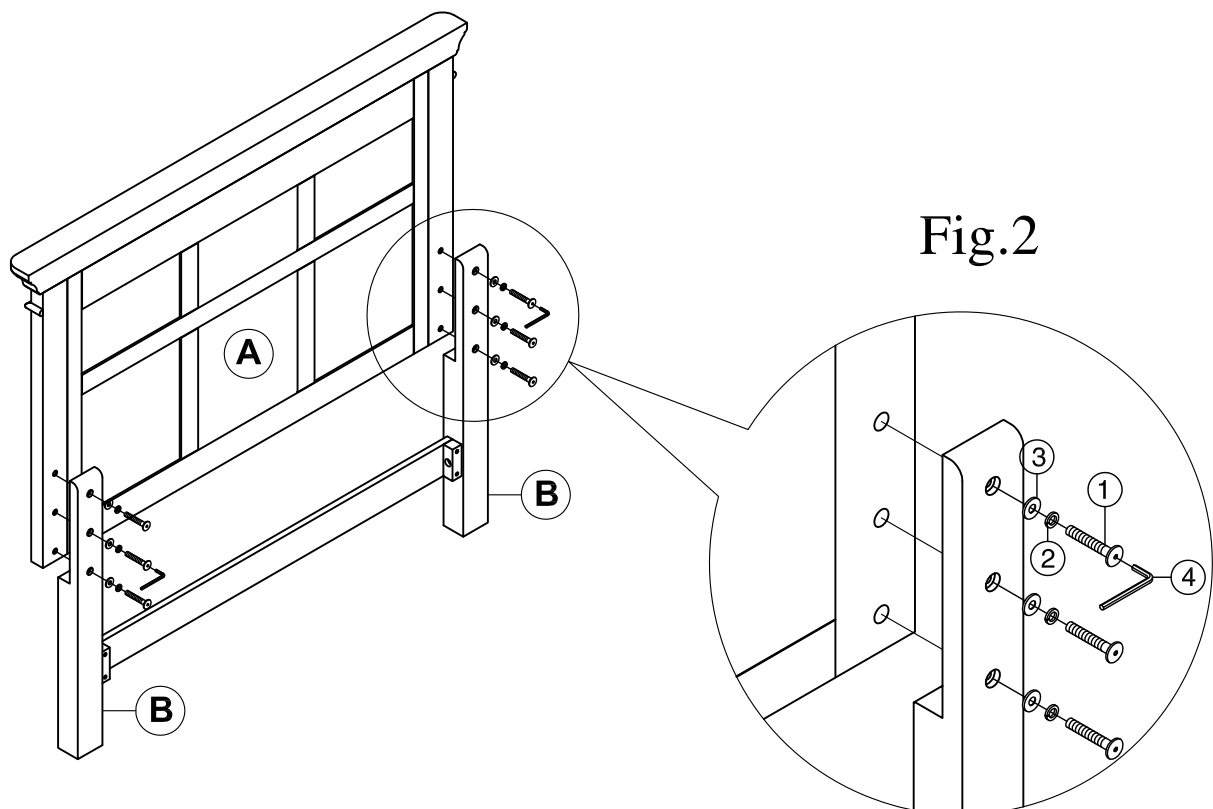

# ASSEMBLY INSTRUCTIONS

## STEP 3:

Attached the slats (E) to the Support Leg (F) using the provided hardware as shown on Fig.3.

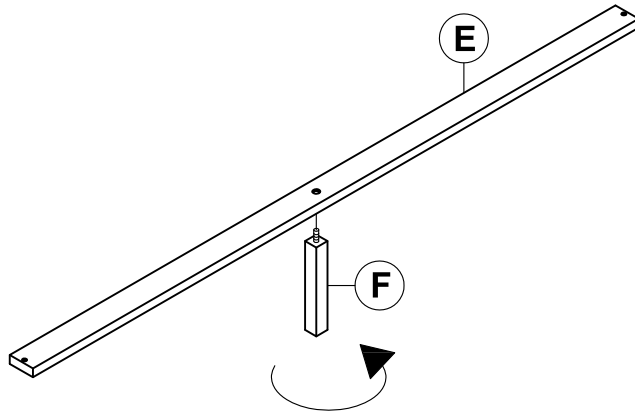

Fig.3

## STEP 4:

Attached Side Rail (H) to the Head Board (A) and Foot Board (D) using the provided hardware as shown on Fig.4.

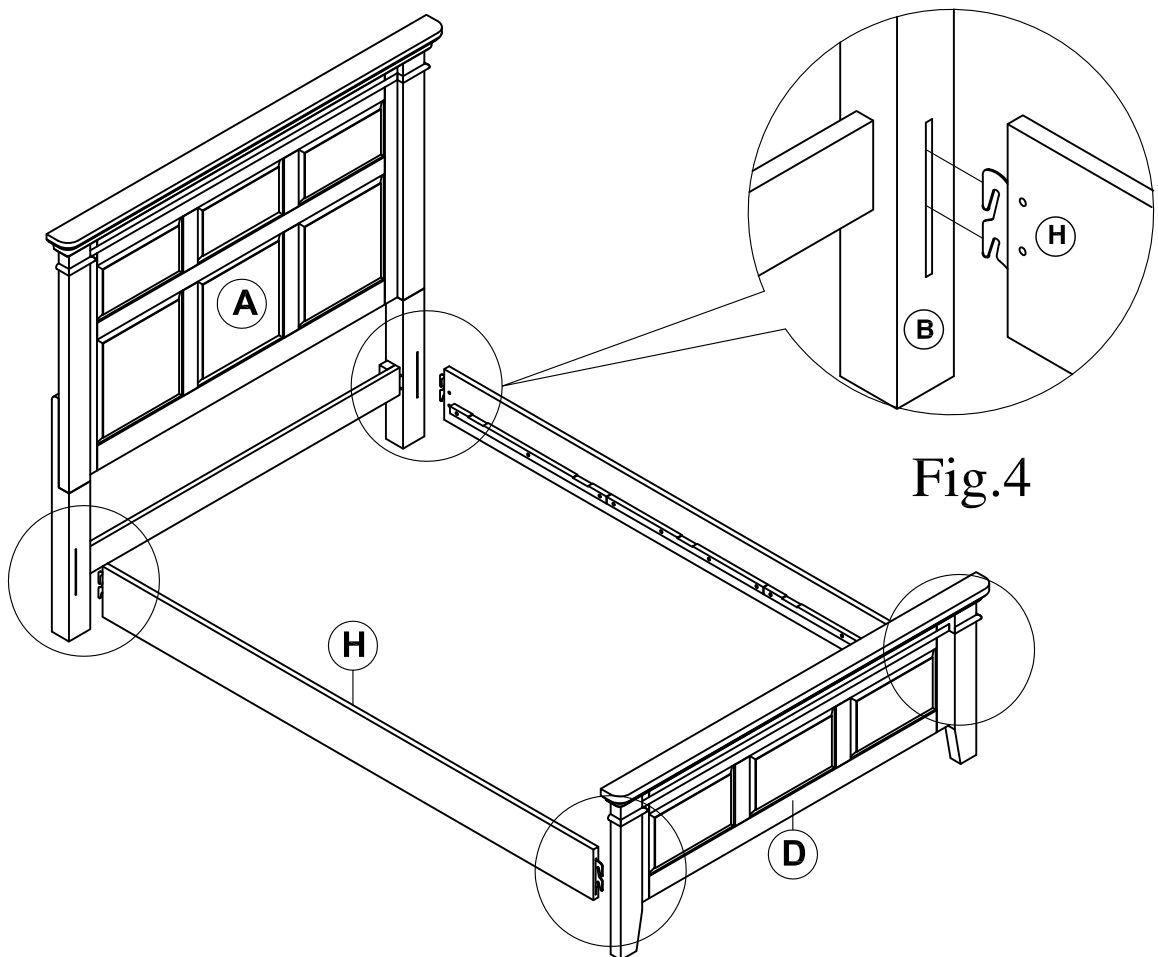

Fig.4

# ASSEMBLY INSTRUCTIONS

## STEP 5:

Attached the slats (E) to the Side Rail (H) using the provided hardware as shown on Fig.5.

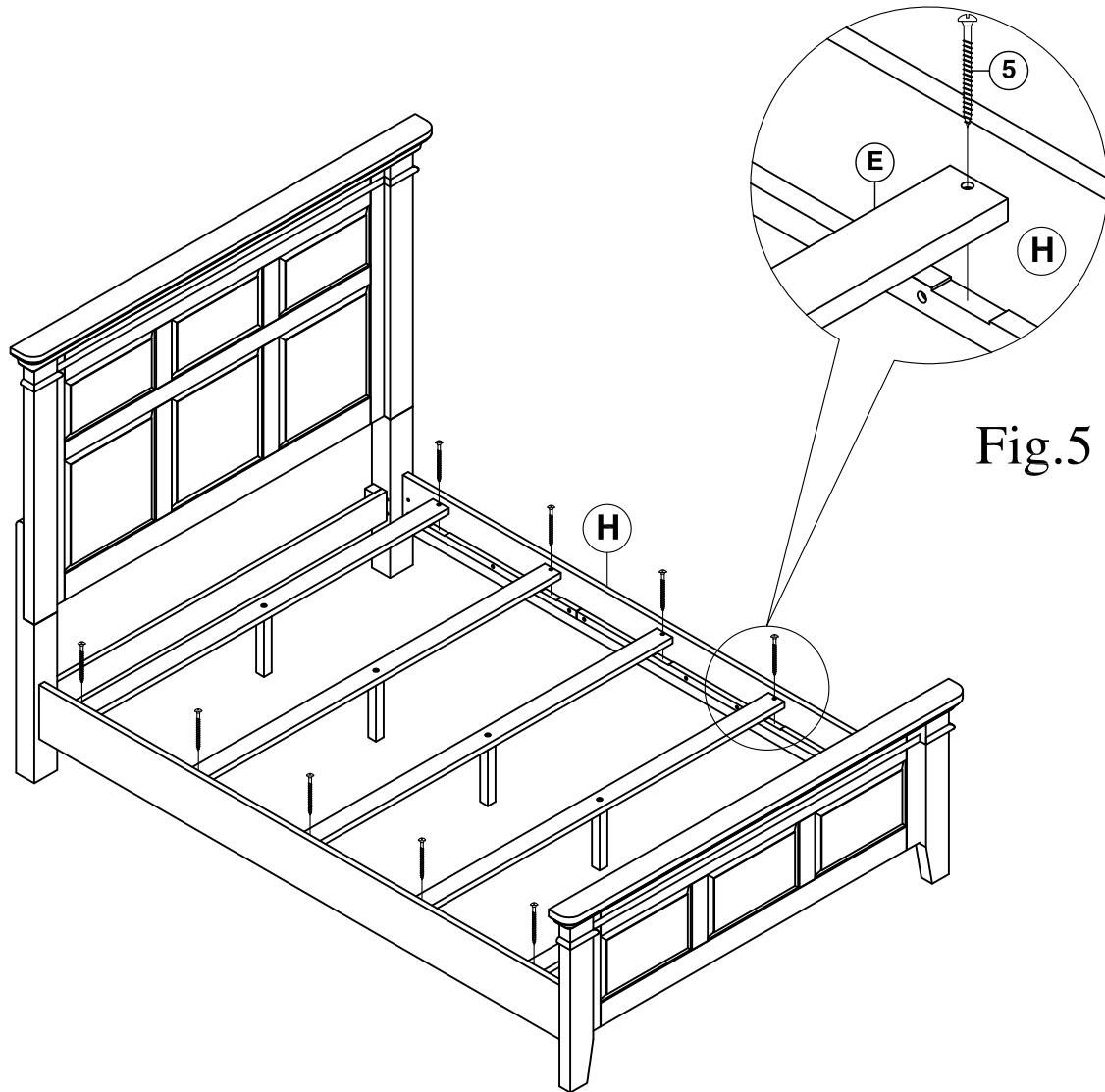

Fig.5